

THIS DRAWING IS UNPUBLISHED. RELEASED FOR PUBLICATION  
 © COPYRIGHT - By - ALL RIGHTS RESERVED.

LOC		DIST		REVISIONS			
P	LTR	DESCRIPTION		DATE	DWN	APVD	
AF	50	D		REVISED PER ECR-13-011489	12DEC2013	KH	PD

- 1 DIMENSIONS IN BRACKETS ARE IN INCHES.
- 2 CONTINUOUS STRIP ON REELS.
- 3 THE  $\frac{0.76}{0.64}$  DIMENSION MUST BE MAINTAINED BY THE APPLICATOR CUT-OFF TO ENSURE THE PROPER LOCKING FUNCTION OF THE RECEPTACLE.
- 4 WIRE SIZES #20-#16, INSULATION RANGE IS 2.29-3.30 [.090-.130] DIA.
- 5 THIS PART MATES WITH P/N 1217716-1.

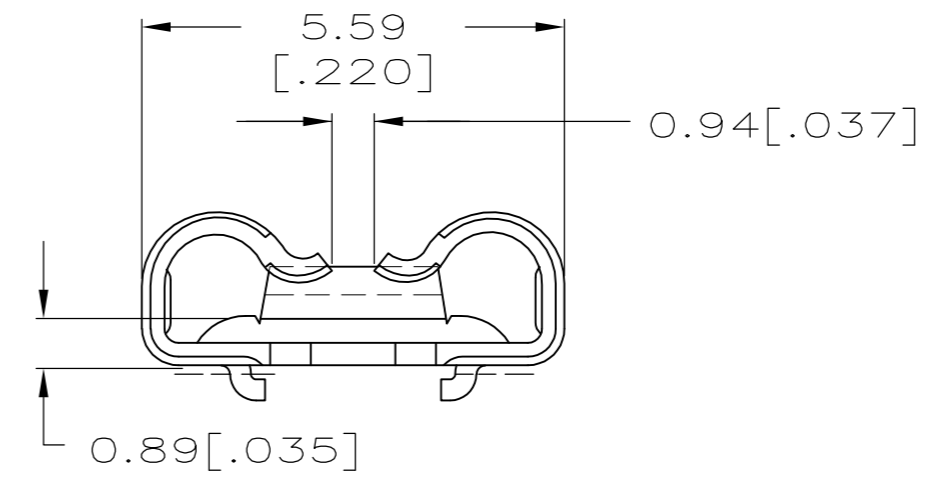
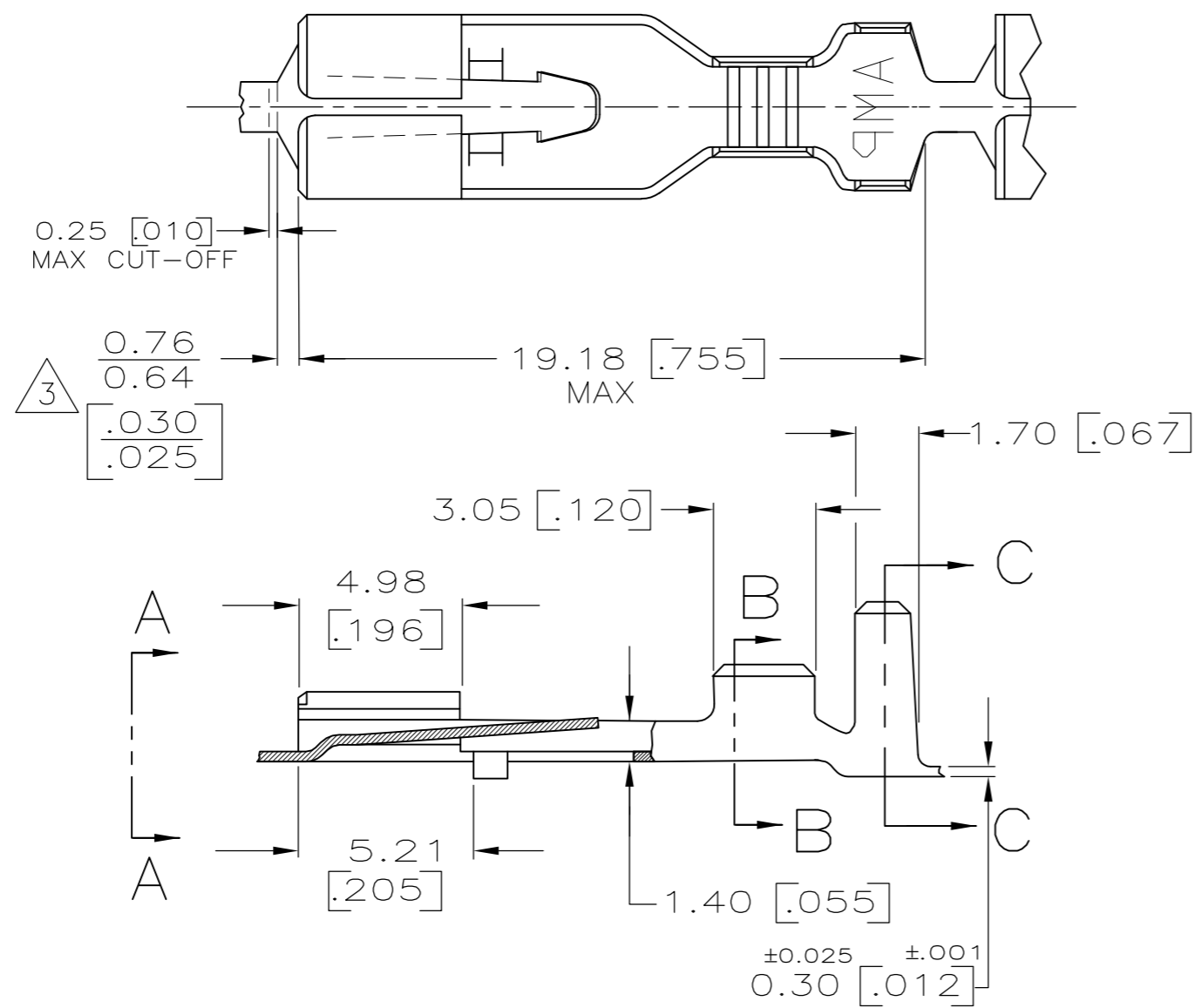

VIEW A-A

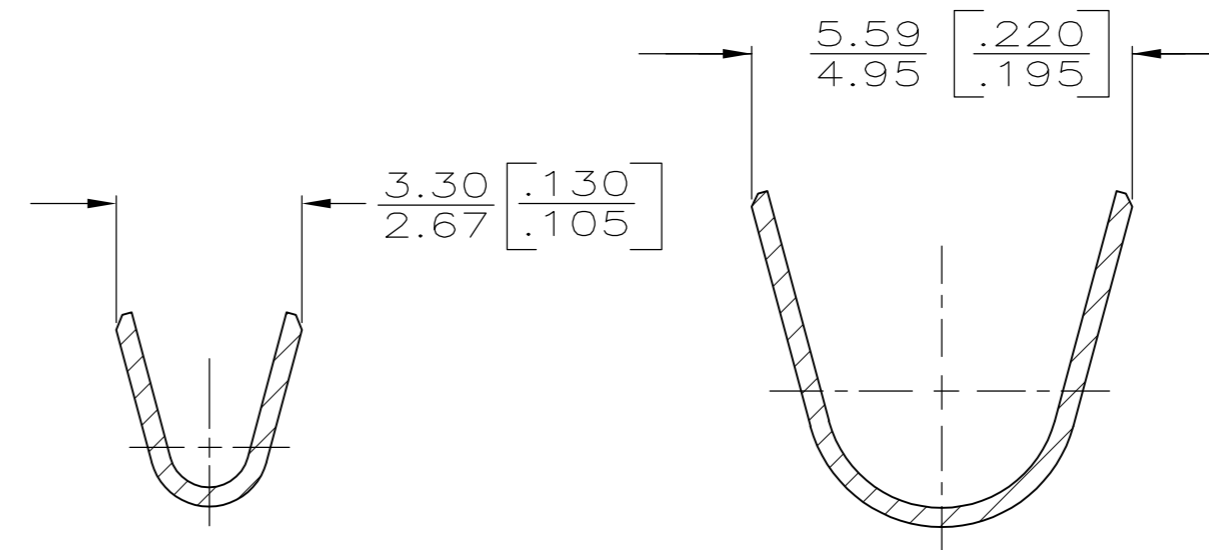

SECTION B-B

SECTION C-C

1217715-1  
PART NO.

THIS DRAWING IS A CONTROLLED DOCUMENT.		DWN	JR RUTH	27SEP01	 TE Connectivity	NAME		RECEPTACLE, SPECIAL, .187 SERIES		
DIMENSIONS: mm [INCHES]		CHK	D DECKER	27SEP01		PRODUCT SPEC		SIZE	CAGE CODE	DRAWING NO
TOLERANCES UNLESS OTHERWISE SPECIFIED:		APVD	D DECKER	27SEP01		APPLICATION SPEC		A2	00779	C=1217715
0 PLC ± - 1 PLC ± - 2 PLC ± 0.25 [.010] 3 PLC ± - 4 PLC ± - ANGLES ± -		MATERIAL	BRASS	FINISH		.000080 MIN TIN	WEIGHT	-	SCALE	5:1
CUSTOMER DRAWING						SHEET	1 of 1	REV	D	