

Specification

Date : Jul. 25, 06

TO : Beceem

Approved by

Selling agency
KYOCERA Corporation
(Electronic Components Sales Division)
〒612-8501 6 Takeda Tobadono-cho, Fushimi-ku
Kyoto 612-8501
TEL 075-604-3500, FAX 075-604-3501

Manufacturer
KYOCERA KINSEKI Corporation
〒201-8648 1-8-1 Izumi-Honcho Komae-shi,
Tokyo 201-8648
TEL 03-5497-3111, FAX 03-5497-3209

Let us Submit 1Copy of the approved Specification on the below items.

Product	Crystal Oscillator
Model	KT2520Y40000ECV28TBA (Pb-Free / RoHS Compliant)
Frequency	40.0MHz
Specification No.	_____
Customer Parts No.	_____

Engineering KYOCERA KINSEKI Yamagata Corporation Crystal Oscillator Manufacturing Department Crystal Oscillator Engineering section	Issued by Y. Kakuta <i>Y. Kakuta</i>	Approved by Y. Tachiiri <i>Y. Tachiiri</i>	Drawing No. K1101-06241-581
--	--	--	--------------------------------

※Recycled paper is being used for the conservation of nature.

KYOCERA KINSEKI Corporation

KBSK-5110C

Revision History

Revision No.	Revision Date	Customer Receipt Date	Supplier Receipt Date	Revision Content and reason	Notes	Approved by	Checked by	Prepared by
1	06/07/25			<input checked="" type="radio"/> Document not based on Beceem Specification. <input type="radio"/> The first edition.		<i>F. Tachibana</i>	X	<i>F. Kikuchi</i>
KYOCERA KINSEKI Corporation				Dwg. Date	2006/7/25	Dwg. No.	K1101-06241-581-1/7	

1. Purpose and scope

This document contains specification related to CRYSTAL OSCILLATOR model KT2520Y40000ECV28TBA for Beceem.

2. Nominal condition

	Item	Rating
1	Operating temperature range	-30°C to +80°C
2	Storage temperature range	-40°C to +85°C
3	Nominal frequency	40.0 MHz
4	Supply voltage	2.8V±5%
5	Load impedance	10kΩ//10pF±10%
6	Output signal condition	Clipped sine wave (Without DC-cut)

3. Electrical characteristics

Ta= -30°C to +80°C, Vcc=2.8V, Vc=GND, Load 10kΩ//10pF

	Item	Specification
1	Frequency stability	
	1	Temp characteristics ±2.5 × 10 ⁻⁶ max./-30°C to +80°C (On the basis of 25°C frequency)
	2	Voltage characteristics ±0.3 × 10 ⁻⁶ max./2.8V±5%
	3	Load characteristics ±0.3 × 10 ⁻⁶ max./10kΩ//10pF±10%
	4	Aging characteristics ±1.0 × 10 ⁻⁶ max./year (at 25°C±2°C)
	5	Frequency Tolerance ±1.5 × 10 ⁻⁶ max. (After reflow soldering. Ref. at nominal frequency) (at 25°C±2°C)
2	Current	2.0 mA max.
3	Output voltage	0.8 Vp-p min.
4	Harmonics	-5dBc max.

4. TYPICAL EXTERNAL COMPONENT CONNECTION

※1 Bypass Capacitor and DC-Blocking Capacitor do not build in this TCXO. So, Bypass Capacitor and DC-Blocking Capacitor are attached outside and please use it. And these Capacitor should be placed as close as possible to the pin(No.3 and No.4). ※2

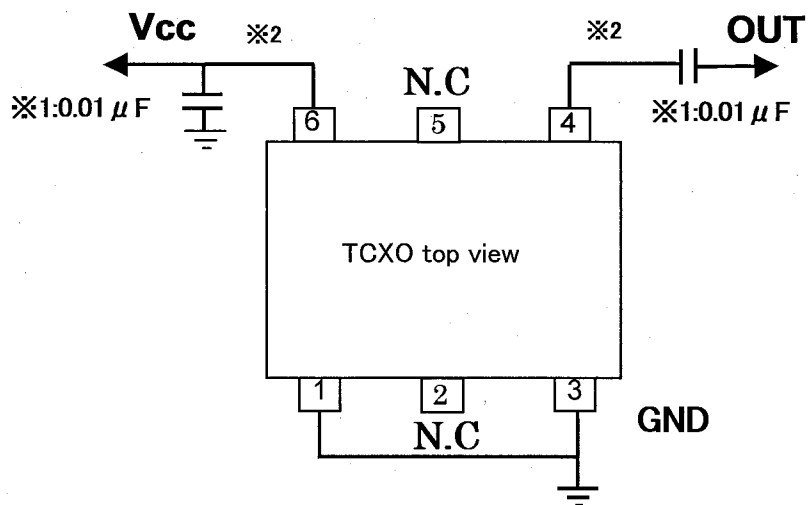

5. ELECTRICAL MEASUREMENT SYSTEM DIAGRAM

※Load $10\text{k}/10\text{pF}$ contains
The internal impedance of FET probe

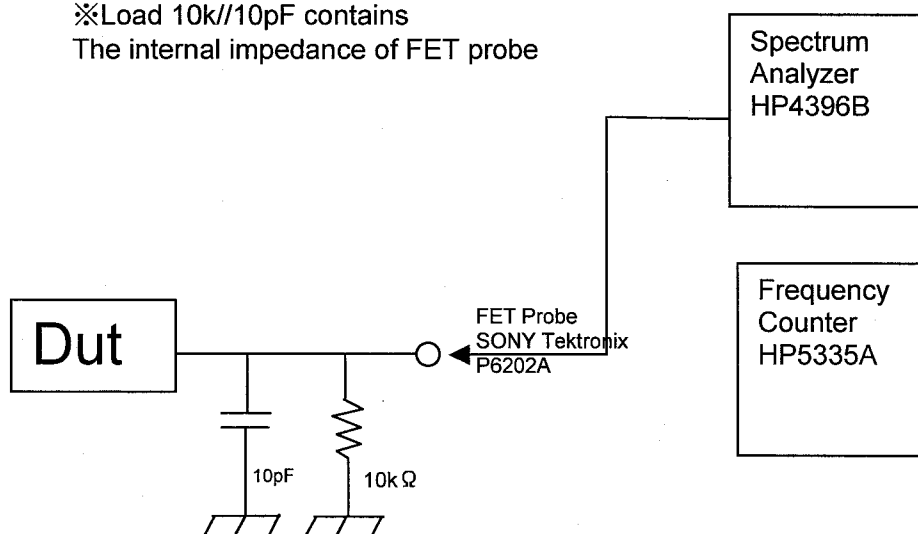

6. Reflow

Surface of mother board

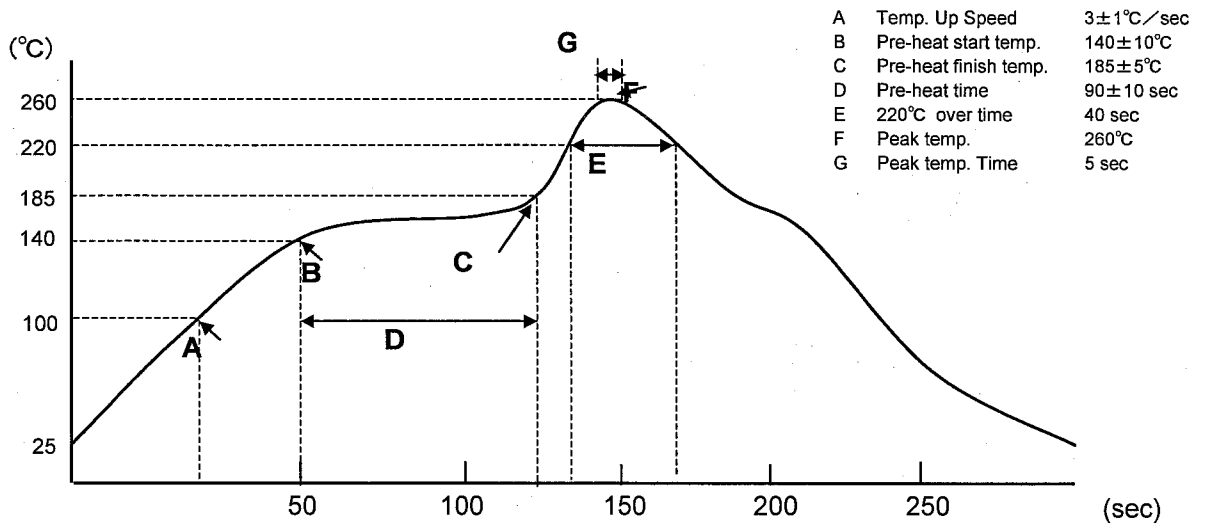

7. Dimensions

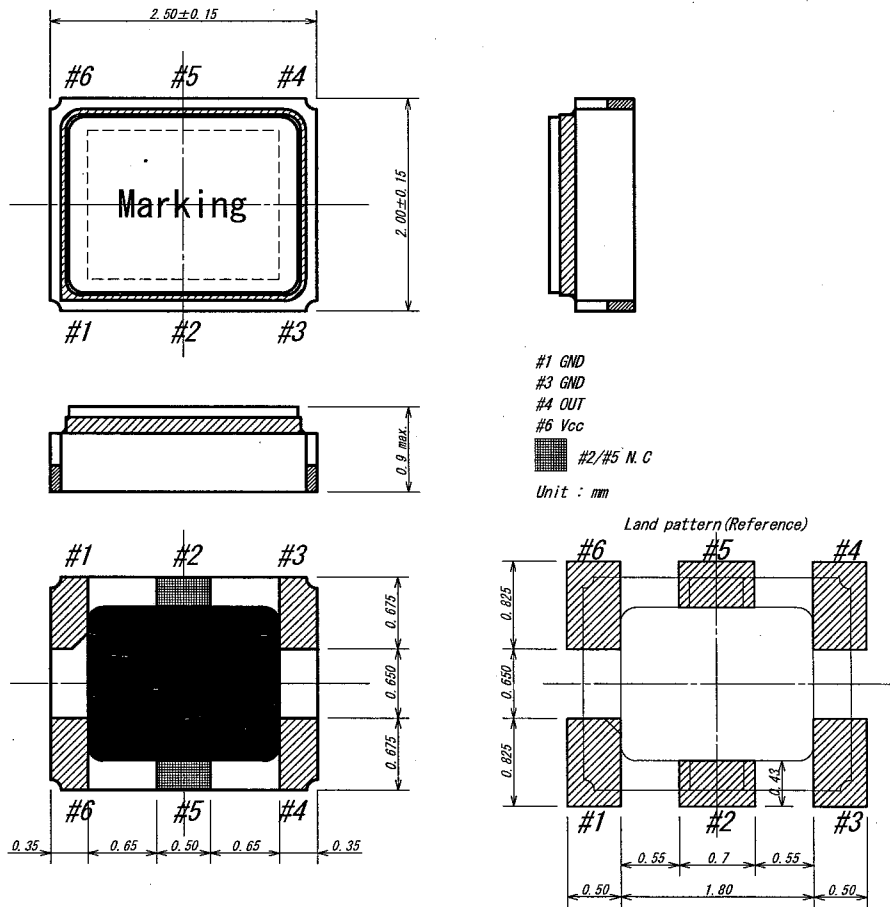

8.Packing and shipping

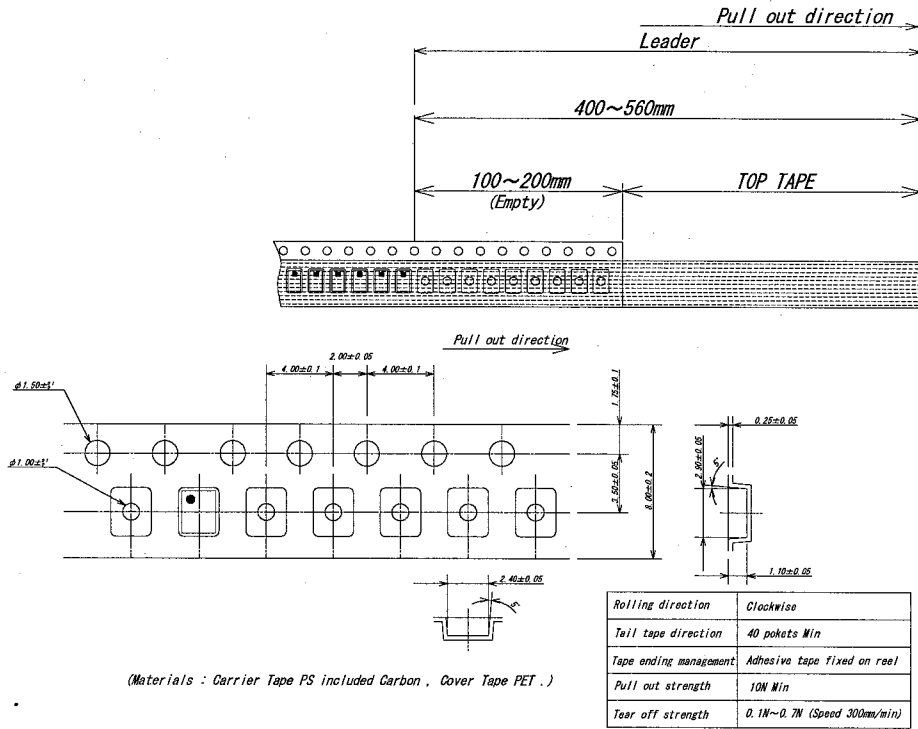

(Materials : Carrier Tape PS included Carbon , Cover Tape PET .)

Reel Dimensions

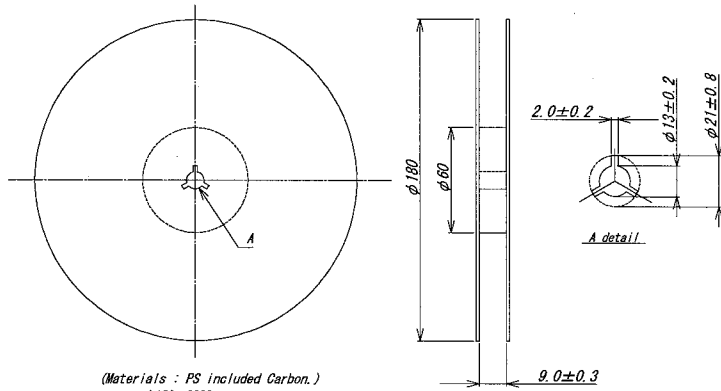

(Materials : PS included Carbon.)
φ180 2000pcs max.

- ① Reel diameter φ180
- ② Quantity 2000pcs
- ③ Tape width 8mm
- ④ Tape pitch 4mm
- ⑤ Set direction Guide side , Fiducoil marking
- ⑥ For exclusive label No.

9. Parts Numbering Guide

KT2520Y 40000 E C V 28 T BA
A B C D E F G H

- A. Series (2.5 × 2.0 SMD KT2520Y)
- B. Frequency (40.0MHz)
- C. Frequency temperature accuracy (E : ±2.5ppm)
- D. Minimum temperature range (C :-30°C)
- E. Maximum temperature range (V :+80°C)
- F. Supply voltage (28 : 2.8V)
- G. Control voltage stability (T :TCXO)
- H. Customer special model Suffix