

LMH6644-MIL Low-Power, 130-MHz, 75-mA Rail-to-Rail Output Amplifier

1 Features

($V_S = \pm 5\text{ V}$, $T_A = 25^\circ\text{C}$, $R_L = 2\text{ k}\Omega$, $A_V = +1$. Typical Values Unless Specified).

- -3 dB BW ($A_V = +1$) 130 MHz
- Supply Voltage Range 2.7 V to 12.8 V
- Slew Rate, ($A_V = -1$) 130 V/ μs ⁽¹⁾
- Supply Current (no load) 2.7 mA/amp
- Output Short Circuit Current +115 mA to 145 mA
- Linear Output Current $\pm 75\text{ mA}$
- Input Common Mode Voltage 0.5 V Beyond V^- , 1 V from V^+
- Output Voltage Swing 40 mV from Rails
- Input Voltage Noise (100 kHz) 17 nV/ $\sqrt{\text{Hz}}$
- Input Current Noise (100 kHz) 0.9 pA/ $\sqrt{\text{Hz}}$
- THD (5 MHz, $R_L = 2\text{ k}\Omega$, $V_O = 2\text{ V}_{PP}$, $A_V = +2$) -62 dBc
- Settling Time 68 ns
- Fully Characterized for 3 V, 5 V, and $\pm 5\text{ V}$
- Overdrive Recovery 100 ns
- Output Short Circuit Protected⁽²⁾
- No Output Phase Reversal with CMVR Exceeded

⁽¹⁾ Slew rate is the average of the rising and falling slew rates.

⁽²⁾ Output short circuit duration is infinite for $V_S < 6\text{ V}$ at room temperature and below. For $V_S > 6\text{ V}$, allowable short circuit duration is 1.5 ms.

2 Applications

- Active Filters
- CD/DVD ROM
- ADC Buffer Amp
- Portable Video
- Current Sense Buffer

3 Description

The LMH6644-MIL true single supply voltage feedback amplifier offers high speed (130 MHz), low distortion (-62 dBc), and exceptionally high-output current (approximately 75 mA) at low cost and with reduced power consumption when compared against existing devices with similar performance.

Input common mode voltage range extends to 0.5 V below V^- and 1 V from V^+ . Output voltage range extends to within 40 mV of either supply rail, allowing wide dynamic range especially desirable in low-voltage applications. The output stage is capable of approximately 75 mA in order to drive heavy loads. Fast output slew rate (130 V/ μs) ensures large peak-to-peak output swings can be maintained even at higher speeds, resulting in exceptional full power bandwidth of 40 MHz with a 3-V supply. These characteristics, along with low cost, are ideal features for a multitude of industrial and commercial applications.

Device Information⁽¹⁾

PART NUMBER	PACKAGE	BODY SIZE (NOM)
LMH6644-MIL	SOIC (14)	8.64 mm × 3.91 mm
	TSSOP (14)	5.00 mm × 4.40 mm

⁽¹⁾ For all available packages, see the orderable addendum at the end of the datasheet.

Closed Loop Gain vs Frequency for Various Supplies

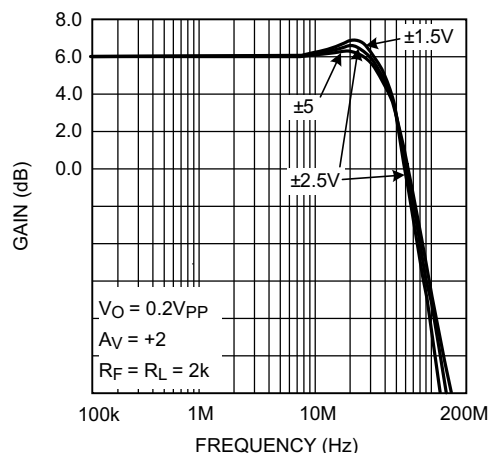

Table of Contents

1 Features	1	8.2 Functional Block Diagram	21
2 Applications	1	8.3 Feature Description	21
3 Description	1	8.4 Device Functional Modes	21
4 Revision History	2	9 Application and Implementation	22
5 Description (continued)	3	9.1 Application Information	22
6 Pin Configuration and Functions	4	9.2 Typical Application	22
7 Specifications	5	10 Power Supply Recommendations	24
7.1 Absolute Maximum Ratings	5	11 Layout	25
7.2 ESD Ratings	5	11.1 Layout Guidelines	25
7.3 Recommended Operating Conditions	5	11.2 Layout Example	25
7.4 Thermal Information	5	12 Device and Documentation Support	26
7.5 3-V Electrical Characteristics	6	12.1 Receiving Notification of Documentation Updates	26
7.6 5-V Electrical Characteristics	8	12.2 Community Resources	26
7.7 \pm 5-V Electrical Characteristics	10	12.3 Trademarks	26
7.8 Typical Performance Characteristics	12	12.4 Electrostatic Discharge Caution	26
8 Detailed Description	21	12.5 Glossary	26
8.1 Overview	21	13 Mechanical, Packaging, and Orderable Information	26

4 Revision History

NOTE: Page numbers for previous revisions may differ from page numbers in the current version.

DATE	REVISION	NOTES
June 2017	*	Initial release.

5 Description (continued)

Careful attention has been paid to ensure device stability under all operating voltages and modes. The result is a very well behaved frequency response characteristic (0.1-dB gain flatness up the 12 MHz under 150- Ω load and $A_V = +2$) with minimal peaking (typically 2-dB maximum) for any gain setting and under both heavy and light loads. This along with fast settling time (68 ns) and low distortion allows the device to operate well in an ADC buffer as well as high-frequency filter applications.

This device offers professional quality video performance with low differential gain (0.01%) and differential phase (0.01°) characteristics. Differential gain and differential phase characteristics are also well maintained under heavy loads (150 Ω) and throughout the output voltage range.

6 Pin Configuration and Functions

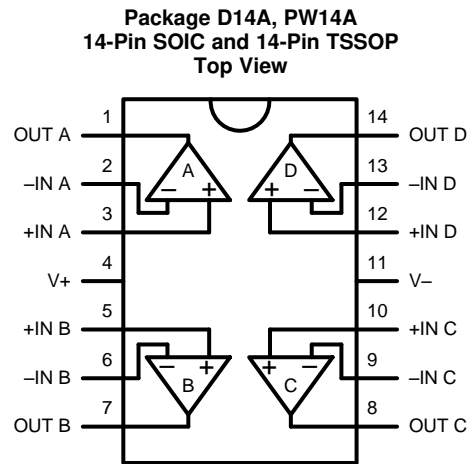

Pin Functions

PIN		I/O	DESCRIPTION
NAME	NO.		
-IN A	2	I	ChA inverting input
+IN A	3	I	ChA non-inverting input
-IN B	6	I	ChB inverting input
+IN B	5	I	ChB non-inverting input
-IN C	9	I	ChC inverting input
+IN C	10	I	ChC non-inverting input
-IN D	13	I	ChD inverting input
+IN D	12	I	ChD non-inverting input
OUT A	1	O	ChA output
OUT B	7	O	ChB output
OUT C	8	O	ChC output
OUT D	14	O	ChD output
V ⁻	11	I	Negative supply
V ⁺	4	I	Positive supply

7 Specifications

7.1 Absolute Maximum Ratings⁽¹⁾⁽²⁾

over operating free-air temperature range (unless otherwise noted)

	MIN	MAX	UNIT
V _{IN} differential		±2.5	V
Output short circuit duration	See ⁽³⁾ and ⁽⁴⁾		
Supply voltage (V ⁺ – V ⁻)		13.5	V
Voltage at input/output pins		V ⁺ +0.8 V ⁻ –0.8	V
Input current		±10	mA
Junction temperature ⁽⁵⁾		+150	°C
Soldering information	Infrared or convection reflow (20 s)	235	°C
	Wave soldering lead temperature (10 s)	260	°C
Storage temperature range, T _{stg}	-65	+150	°C

- (1) Absolute Maximum Ratings indicate limits beyond which damage to the device may occur. Operating Ratings indicate conditions for which the device is intended to be functional, but specific performance is not ensured. For ensured specifications and the test conditions, see the Electrical Characteristics.
- (2) If Military/Aerospace specified devices are required, please contact the TI Sales Office/Distributors for availability and specifications.
- (3) Applies to both single-supply and split-supply operation. Continuous short circuit operation at elevated ambient temperature can result in exceeding the maximum allowed junction temperature of 150°C.
- (4) Output short circuit duration is infinite for V_S < 6V at room temperature and below. For V_S > 6V, allowable short circuit duration is 1.5ms.
- (5) The maximum power dissipation is a function of T_{J(MAX)}, R_{θJA}, and T_A. The maximum allowable power dissipation at any ambient temperature is P_D = (T_{J(MAX)} – T_A) / R_{θJA}. All numbers apply for packages soldered directly onto a PC board.

7.2 ESD Ratings

	VALUE	UNIT
V _(ESD) Electrostatic discharge ⁽¹⁾	Human-body model (HBM), per ANSI/ESDA/JEDEC JS-001, all pins ⁽²⁾	2000
	Machine model (MM) ⁽³⁾	200
	Charged-device model (CDM), per JEDEC specification JESD22-C101, all pins ⁽⁴⁾	1000

- (1) Human body model, 1.5 kΩ in series with 100 pF. Machine Model, 0 Ω in series with 200 pF.
- (2) JEDEC document JEP155 states that 2000-V HBM allows safe manufacturing with a standard ESD control process.
- (3) JEDEC document JEP157 states that 200-V MM allows safe manufacturing with a standard ESD control process.
- (4) JEDEC document JEP157 states that 1000-V CDM allows safe manufacturing with a standard ESD control process.

7.3 Recommended Operating Conditions⁽¹⁾

over operating free-air temperature range (unless otherwise noted)

	MIN	MAX	UNIT
Supply voltage (V ⁺ – V ⁻)	2.7	12.8	V
Operating temperature range ⁽²⁾	-40	+85	°C

- (1) Absolute Maximum Ratings indicate limits beyond which damage to the device may occur. Operating Ratings indicate conditions for which the device is intended to be functional, but specific performance is not ensured. For ensured specifications and the test conditions, see the Electrical Characteristics.
- (2) The maximum power dissipation is a function of T_{J(MAX)}, R_{θJA}, and T_A. The maximum allowable power dissipation at any ambient temperature is P_D = (T_{J(MAX)} – T_A) / R_{θJA}. All numbers apply for packages soldered directly onto a PC board.

7.4 Thermal Information

THERMAL METRIC ⁽¹⁾	LMH6644-MIL		UNIT
	D14A	PW14A	
	14 PINS	14 PINS	
R _{θJA} Junction-to-ambient thermal resistance ⁽²⁾	145	155	°C/W

- (1) For more information about traditional and new thermal metrics, see the *IC Package Thermal Metrics* application report, [SPRA953](#).
- (2) The maximum power dissipation is a function of T_{J(MAX)}, R_{θJA}, and T_A. The maximum allowable power dissipation at any ambient temperature is P_D = (T_{J(MAX)} – T_A) / R_{θJA}. All numbers apply for packages soldered directly onto a PC board.

7.5 3-V Electrical Characteristics

Unless otherwise specified, all limits ensured for $V^+ = 3\text{ V}$, $V^- = 0\text{ V}$, $V_{CM} = V_O = V^+/2$, V_{ID} (input differential voltage) as noted (where applicable) and $R_L = 2\text{ k}\Omega$ to $V^+/2$

PARAMETER	TEST CONDITIONS	AT TEMPERATURE EXTREMES			$V^+ = 3\text{ V}$, $V^- = 0\text{ V}$, $V_{CM} = V_O = V^+/2$, V_{ID} $R_L = 2\text{ k}\Omega$ to $V^+/2$			UNIT
		MIN	TYP	MAX	MIN ⁽¹⁾	TYP ⁽²⁾	MAX ⁽¹⁾	
BW	–3-dB BW	$A_V = +1$, $V_{OUT} = 200\text{mV}_{PP}$			80	115		MHz
		$A_V = +2$, -1 , $V_{OUT} = 200\text{mV}_{PP}$				46		
$BW_{0.1dB}$	0.1-dB gain flatness	$A_V = +2$, $R_L = 150\Omega$ to $V^+/2$, $R_f = 402\Omega$, $V_{OUT} = 200\text{mV}_{PP}$				19		MHz
PBW	Full power bandwidth	$A_V = +1$, -1dB , $V_{OUT} = 1\text{V}_{PP}$				40		MHz
e_n	Input-referred voltage noise	$f = 100\text{kHz}$				17		$\text{nV}/\sqrt{\text{Hz}}$
		$f = 1\text{kHz}$				48		
i_n	Input-referred current noise	$f = 100\text{kHz}$				0.90		$\text{pA}/\sqrt{\text{Hz}}$
		$f = 1\text{kHz}$				3.3		
THD	Total harmonic distortion	$f = 5\text{MHz}$, $V_O = 2\text{V}_{PP}$, $A_V = -1$, $R_L = 100\Omega$ to $V^+/2$				–48		dBc
DG	Differential gain	$V_{CM} = 1\text{V}$, NTSC, $A_V = +2$ $R_L = 150\Omega$ to $V^+/2$				0.17%		
		$R_L = 1\text{k}\Omega$ to $V^+/2$				0.03%		
DP	Differential phase	$V_{CM} = 1\text{V}$, NTSC, $A_V = +2$ $R_L = 150\Omega$ to $V^+/2$				0.05		deg
		$R_L = 1\text{k}\Omega$ to $V^+/2$				0.03		
CT Rej.	Cross-talk rejection	$f = 5\text{MHz}$, receiver: $R_f = R_g = 510\Omega$, $A_V = +2$				47		dB
T_S	Settling time	$V_O = 2\text{V}_{PP}$, $\pm 0.1\%$, 8pF Load, $V_S = 5\text{V}$				68		ns
SR	Slew rate ⁽³⁾	$A_V = -1$, $V_I = 2\text{V}_{PP}$			90	120		$\text{V}/\mu\text{s}$
V_{OS}	Input offset voltage			± 7		± 1	± 5	mV
TC V_{OS}	Input offset average drift	See ⁽⁴⁾				± 5		$\mu\text{V}/^\circ\text{C}$
I_B	Input bias current	See ⁽⁵⁾			–3.25	–1.50	–2.60	μA
I_{OS}	Input offset current			1000		20	800	nA
R_{IN}	Common-mode input resistance					3		$\text{M}\Omega$

(1) All limits are ensured by testing or statistical analysis.

(2) Typical values represent the most likely parametric norm.

(3) Slew rate is the average of the rising and falling slew rates.

(4) Offset voltage average drift determined by dividing the change in V_{OS} at temperature extremes by the total temperature change.

(5) Positive current corresponds to current flowing into the device.

3-V Electrical Characteristics (continued)

Unless otherwise specified, all limits ensured for $V^+ = 3\text{ V}$, $V^- = 0\text{ V}$, $V_{CM} = V_O = V^+/2$, V_{ID} (input differential voltage) as noted (where applicable) and $R_L = 2\text{ k}\Omega$ to $V^+/2$

PARAMETER	TEST CONDITIONS	AT TEMPERATURE EXTREMES			$V^+ = 3\text{ V}$, $V^- = 0\text{ V}$, $V_{CM} = V_O = V^+/2$, V_{ID} $R_L = 2\text{ k}\Omega$ to $V^+/2$			UNIT	
		MIN	TYP	MAX	MIN ⁽¹⁾	TYP ⁽²⁾	MAX ⁽¹⁾		
C_{IN}	Common-mode input capacitance					2		pF	
$CMVR$	Input common-mode voltage range	$CMRR \geq 50\text{dB}$			-0.1	-0.5	-0.2	V	
			1.6		1.8	2.0			
$CMRR$	Common-mode rejection ratio	V_{CM} Stepped from 0V to 1.5V				72	95	dB	
A_{VOL}	Large signal voltage gain	$V_O = 0.5\text{V}$ to 2.5V $R_L = 2\text{k}\Omega$ to $V^+/2$	75			80	96	dB	
		$V_O = 0.5\text{V}$ to 2.5V $R_L = 150\Omega$ to $V^+/2$	70			74	82		
V_O	Output swing high	$R_L = 2\text{k}\Omega$ to $V^+/2$, $V_{ID} = 200\text{mV}$				2.90	2.98	V	
		$R_L = 150\Omega$ to $V^+/2$, $V_{ID} = 200\text{mV}$				2.80	2.93		
	Output swing low	$R_L = 2\text{k}\Omega$ to $V^+/2$, $V_{ID} = -200\text{mV}$					25	75	mV
		$R_L = 150\Omega$ to $V^+/2$, $V_{ID} = -200\text{mV}$					75	150	
I_{SC}	Output short circuit current	Sourcing to $V^+/2$ $V_{ID} = 200\text{mV}$ ⁽⁶⁾	35			50	95	mA	
		Sinking to $V^+/2$ $V_{ID} = -200\text{mV}$ ⁽⁶⁾	40			55	110		
I_{OUT}	Output current	$V_{OUT} = 0.5\text{V}$ from either supply					± 65	mA	
+PSRR	Positive power supply rejection ratio	$V^+ = 3.0\text{V}$ to 3.5V , $V_{CM} = 1.5\text{V}$				75	85	dB	
I_S	Supply current (per channel)	No load			4.50		2.70 4.00	mA	

(6) Short circuit test is a momentary test. See [Note 7](#) under 5-V Electrical Characteristics.

7.6 5-V Electrical Characteristics

Unless otherwise specified, all limits ensured for $V^+ = 5\text{ V}$, $V^- = 0\text{ V}$, $V_{CM} = V_O = V^+/2$, V_{ID} (input differential voltage) as noted (where applicable) and $R_L = 2\text{ k}\Omega$ to $V^+/2$

PARAMETER	TEST CONDITIONS	AT TEMPERATURE EXTREMES			$V^+ = 5\text{ V}$, $V^- = 0\text{ V}$, $V_{CM} = V_O = V^+/2$, V_{ID} $R_L = 2\text{ k}\Omega$ to $V^+/2$			UNIT
		MIN	TYP	MAX	MIN ⁽¹⁾	TYP ⁽²⁾	MAX ⁽¹⁾	
BW	–3-dB BW	$A_V = +1$, $V_{OUT} = 200\text{mV}_{PP}$			90	120		MHz
		$A_V = +2$, -1 , $V_{OUT} = 200\text{mV}_{PP}$				46		
$BW_{0.1dB}$	0.1-dB gain flatness	$A_V = +2$, $R_L = 150\Omega$ to $V^+/2$, $R_f = 402\Omega$, $V_{OUT} = 200\text{mV}_{PP}$				15		MHz
PBW	Full power bandwidth	$A_V = +1$, -1dB , $V_{OUT} = 2V_{PP}$				22		MHz
e_n	Input-referred voltage noise	$f = 100\text{kHz}$				17		$\text{nV}/\sqrt{\text{Hz}}$
		$f = 1\text{kHz}$				48		
i_n	Input-referred current noise	$f = 100\text{kHz}$				0.90		$\text{pA}/\sqrt{\text{Hz}}$
		$f = 1\text{kHz}$				3.3		
THD	Total harmonic distortion	$f = 5\text{MHz}$, $V_O = 2V_{PP}$, $A_V = +2$				–60		dBc
DG	Differential gain	NTSC, $A_V = +2$ $R_L = 150\Omega$ to $V^+/2$				0.16%		
		$R_L = 1\text{k}\Omega$ to $V^+/2$				0.05%		
DP	Differential phase	NTSC, $A_V = +2$ $R_L = 150\Omega$ to $V^+/2$				0.05		deg
		$R_L = 1\text{k}\Omega$ to $V^+/2$				0.01		
CT Rej.	Cross-talk rejection	$f = 5\text{MHz}$, receiver: $R_f = R_g = 510\Omega$, $A_V = +2$				47		dB
T_S	Settling time	$V_O = 2V_{PP}$, $\pm 0.1\%$, 8pF Load				68		ns
SR	Slew rate ⁽³⁾	$A_V = -1$, $V_I = 2V_{PP}$			95	125		$\text{V}/\mu\text{s}$
V_{OS}	Input offset voltage				± 7	± 1	± 5	mV
TC V_{OS}	Input offset average drift	See ⁽⁴⁾				± 5		$\mu\text{V}/^\circ\text{C}$
I_B	Input bias current	See ⁽⁵⁾			–3.25	–1.70	–2.60	μA
I_{OS}	Input offset current				1000	20	800	nA
R_{IN}	Common-mode input resistance					3		$\text{M}\Omega$
C_{IN}	Common-mode input capacitance					2		pF
CMVR	Input common-mode voltage range	CMRR $\geq 50\text{dB}$			–0.1	–0.5	–0.2	V
					3.6	3.8	4.0	
CMRR	Common-mode rejection ratio	V_{CM} Stepped from 0V to 3.5V				72	95	dB
A_{VOL}	Large signal voltage gain	$V_O = 0.5\text{V}$ to 4.50V $R_L = 2\text{k}\Omega$ to $V^+/2$			82	86	98	dB
		$V_O = 0.5\text{V}$ to 4.25V $R_L = 150\Omega$ to $V^+/2$			72	76	82	

(1) All limits are ensured by testing or statistical analysis.

(2) Typical values represent the most likely parametric norm.

(3) Slew rate is the average of the rising and falling slew rates.

(4) Offset voltage average drift determined by dividing the change in V_{OS} at temperature extremes by the total temperature change.

(5) Positive current corresponds to current flowing into the device.

5-V Electrical Characteristics (continued)

Unless otherwise specified, all limits ensured for $V^+ = 5\text{ V}$, $V^- = 0\text{ V}$, $V_{CM} = V_O = V^+/2$, V_{ID} (input differential voltage) as noted (where applicable) and $R_L = 2\text{ k}\Omega$ to $V^+/2$

PARAMETER		TEST CONDITIONS	AT TEMPERATURE EXTREMES			$V^+ = 5\text{ V}$, $V^- = 0\text{ V}$, $V_{CM} = V_O = V^+/2$, V_{ID} $R_L = 2\text{ k}\Omega$ to $V^+/2$			UNIT
			MIN	TYP	MAX	MIN ⁽¹⁾	TYP ⁽²⁾	MAX ⁽¹⁾	
V_O	Output swing high	$R_L = 2\text{ k}\Omega$ to $V^+/2$, $V_{ID} = 200\text{ mV}$				4.90	4.98		V
		$R_L = 150\Omega$ to $V^+/2$, $V_{ID} = 200\text{ mV}$				4.65	4.90		
	Output swing low	$R_L = 2\text{ k}\Omega$ to $V^+/2$, $V_{ID} = -200\text{ mV}$					25	100	mV
		$R_L = 150\Omega$ to $V^+/2$, $V_{ID} = -200\text{ mV}$					100	150	
I_{SC}	Output short circuit current	Sourcing to $V^+/2$ $V_{ID} = 200\text{ mV}$ ⁽⁶⁾⁽⁷⁾	40			55	115		mA
		Sinking to $V^+/2$ $V_{ID} = -200\text{ mV}$ ⁽⁶⁾⁽⁷⁾	55			70	140		
I_{OUT}	Output current	$V_O = 0.5\text{ V}$ from either supply					± 70		mA
+PSRR	Positive power supply rejection ratio	$V^+ = 4.0\text{ V}$ to 6 V				79	90		dB
I_S	Supply current (per channel)	No load			5.00		2.70	4.25	mA

(6) Short circuit test is a momentary test. See [Note 7](#).

(7) Output short circuit duration is infinite for $V_S < 6\text{ V}$ at room temperature and below. For $V_S > 6\text{ V}$, allowable short circuit duration is 1.5ms.

7.7 ±5-V Electrical Characteristics

Unless otherwise specified, all limits ensured for $V^+ = 5\text{ V}$, $V^- = -5\text{ V}$, $V_{\text{CM}} = V_{\text{O}} = 0\text{ V}$, V_{ID} (input differential voltage) as noted (where applicable) and $R_{\text{L}} = 2\text{ k}\Omega$ to ground

PARAMETER	TEST CONDITIONS	AT TEMPERATURE EXTREMES			$V^+ = 5\text{ V}$, $V^- = -5\text{ V}$, $V_{\text{CM}} = V_{\text{O}} = 0\text{ V}$, V_{ID}			UNIT
		MIN	TYP	MAX	MIN ⁽¹⁾	TYP ⁽²⁾	MAX ⁽¹⁾	
BW	–3-dB BW	$A_{\text{V}} = +1$, $V_{\text{OUT}} = 200\text{mV}_{\text{PP}}$			95	130		MHz
		$A_{\text{V}} = +2, -1$, $V_{\text{OUT}} = 200\text{mV}_{\text{PP}}$				46		
BW _{0.1dB}	0.1-dB gain flatness	$A_{\text{V}} = +2$, $R_{\text{L}} = 150\Omega$ to $V^+/2$, $R_{\text{f}} = 806\Omega$, $V_{\text{OUT}} = 200\text{mV}_{\text{PP}}$				12		MHz
PBW	Full power bandwidth	$A_{\text{V}} = +1$, –1dB, $V_{\text{OUT}} = 2\text{V}_{\text{PP}}$				24		MHz
e_{n}	Input-referred voltage noise	$f = 100\text{kHz}$				17		$\text{nV}/\sqrt{\text{Hz}}$
		$f = 1\text{kHz}$				48		
i_{n}	Input-referred current noise	$f = 100\text{kHz}$				0.90		$\text{pA}/\sqrt{\text{Hz}}$
		$f = 1\text{kHz}$				3.3		
THD	Total harmonic distortion	$f = 5\text{MHz}$, $V_{\text{O}} = 2\text{V}_{\text{PP}}$, $A_{\text{V}} = +2$				–62		dBc
DG	Differential gain	NTSC, $A_{\text{V}} = +2$ $R_{\text{L}} = 150\Omega$ to $V^+/2$				0.15%		
		$R_{\text{L}} = 1\text{k}\Omega$ to $V^+/2$				0.01%		
DP	Differential phase	NTSC, $A_{\text{V}} = +2$ $R_{\text{L}} = 150\Omega$ to $V^+/2$				0.04		deg
		$R_{\text{L}} = 1\text{k}\Omega$ to $V^+/2$				0.01		
CT Rej.	Cross-talk rejection	$f = 5\text{MHz}$, receiver: $R_{\text{f}} = R_{\text{g}} = 510\Omega$, $A_{\text{V}} = +2$				47		dB
T_{S}	Settling time	$V_{\text{O}} = 2\text{V}_{\text{PP}}$, $\pm 0.1\%$, 8pF Load, $V_{\text{S}} = 5\text{V}$				68		ns
SR	Slew rate ⁽³⁾	$A_{\text{V}} = -1$, $V_{\text{I}} = 2\text{V}_{\text{PP}}$			100	135		$\text{V}/\mu\text{s}$
V_{OS}	Input offset voltage				± 7	± 1	± 5	mV
TC V_{OS}	Input offset average drift	See ⁽⁴⁾				± 5		$\mu\text{V}/^\circ\text{C}$
I_{B}	Input bias current	See ⁽⁵⁾			–3.25	–1.60	–2.60	μA
I_{OS}	Input offset current				1000	20	800	nA
R_{IN}	Common-mode input resistance					3		$\text{M}\Omega$
C_{IN}	Common-mode input capacitance					2		pF
CMVR	Input common-mode voltage range	CMRR $\geq 50\text{dB}$			–5.1	–5.5	–5.2	V
					3.6	3.8	4.0	
CMRR	Common-mode rejection ratio	V_{CM} Stepped from –5V to 3.5V				74	95	dB

(1) All limits are ensured by testing or statistical analysis.

(2) Typical values represent the most likely parametric norm.

(3) Slew rate is the average of the rising and falling slew rates.

(4) Offset voltage average drift determined by dividing the change in V_{OS} at temperature extremes by the total temperature change.

(5) Positive current corresponds to current flowing into the device.

±5-V Electrical Characteristics (continued)

Unless otherwise specified, all limits ensured for $V^+ = 5\text{ V}$, $V^- = -5\text{ V}$, $V_{CM} = V_O = 0\text{ V}$, V_{ID} (input differential voltage) as noted (where applicable) and $R_L = 2\text{ k}\Omega$ to ground

PARAMETER	TEST CONDITIONS	AT TEMPERATURE EXTREMES			$V^+ = 5\text{ V}$, $V^- = -5\text{ V}$, $V_{CM} = V_O = 0\text{ V}$, V_{ID}			UNIT	
		MIN	TYP	MAX	MIN ⁽¹⁾	TYP ⁽²⁾	MAX ⁽¹⁾		
A_{VOL}	Large signal voltage gain	$V_O = -4.5\text{ V}$ to 4.5 V , $R_L = 2\text{ k}\Omega$	84			88	96	dB	
		$V_O = -4.0\text{ V}$ to 4.0 V , $R_L = 150\Omega$	74			78	82		
V_O	Output swing high	$R_L = 2\text{ k}\Omega$, $V_{ID} = 200\text{ mV}$				4.90	4.96	V	
		$R_L = 150\Omega$, $V_{ID} = 200\text{ mV}$				4.65	4.80		
	Output swing low	$R_L = 2\text{ k}\Omega$, $V_{ID} = -200\text{ mV}$					-4.96	-4.90	V
		$R_L = 150\Omega$, $V_{ID} = -200\text{ mV}$					-4.80	-4.65	
I_{SC}	Output short circuit current	Sourcing to ground $V_{ID} = 200\text{ mV}$ ⁽⁶⁾⁽⁷⁾	35			60	115	mA	
		Sinking to ground $V_{ID} = -200\text{ mV}$ ⁽⁶⁾⁽⁷⁾	65			85	145		
I_{OUT}	Output current	$V_O = 0.5\text{ V}$ from either supply				±75		mA	
PSRR	Power supply rejection ratio	$(V^+, V^-) = (4.5\text{ V}, -4.5\text{ V})$ to $(5.5\text{ V}, -5.5\text{ V})$				78	90	dB	
I_S	Supply current (per channel)	No load			5.50	2.70	4.50	mA	

(6) Short circuit test is a momentary test. See ⁽⁷⁾.

(7) Output short circuit duration is infinite for $V_S < 6\text{ V}$ at room temperature and below. For $V_S > 6\text{ V}$, allowable short circuit duration is 1.5ms.

7.8 Typical Performance Characteristics

$V^+ = +5\text{ V}$, $V^- = -5\text{ V}$, $R_F = R_L = 2\text{ k}\Omega$, unless specified otherwise.

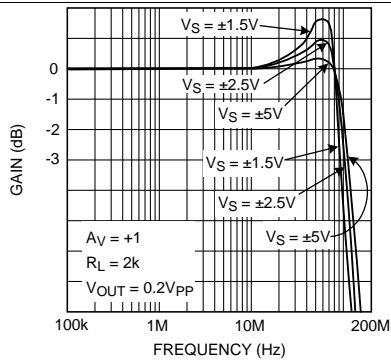

Figure 1. Closed Loop Frequency Response for Various Supplies

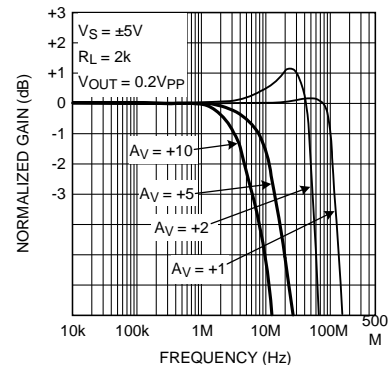

Figure 2. Closed Loop Gain vs Frequency for Various Gain

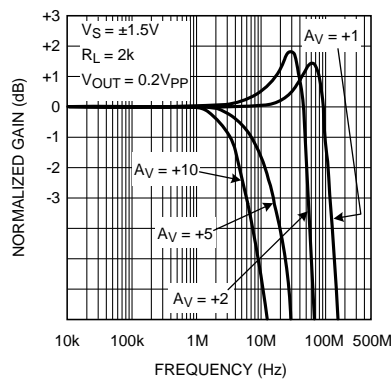

Figure 3. Closed Loop Gain vs Frequency for Various Gain

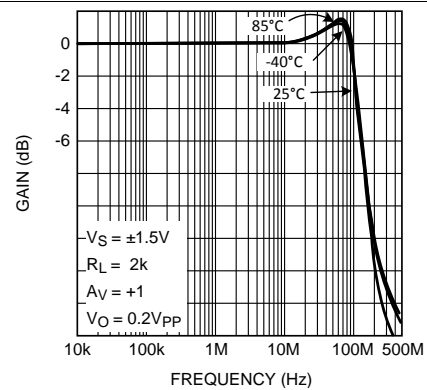

Figure 4. Closed Loop Frequency Response for Various Temperature

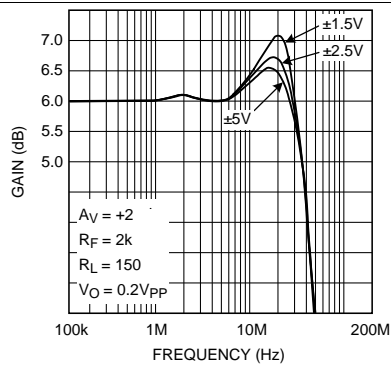

Figure 5. Closed Loop Gain vs Frequency for Various Supplies

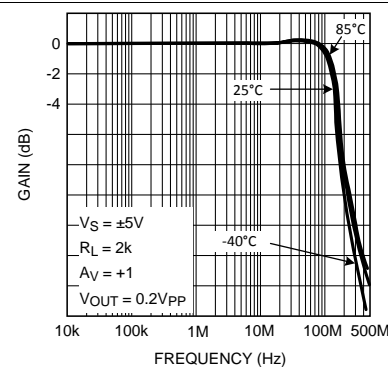

Figure 6. Closed Loop Frequency Response for Various Temperature

Typical Performance Characteristics (continued)

$V^+ = +5\text{ V}$, $V^- = -5\text{ V}$, $R_F = R_L = 2\text{ k}\Omega$, unless specified otherwise.

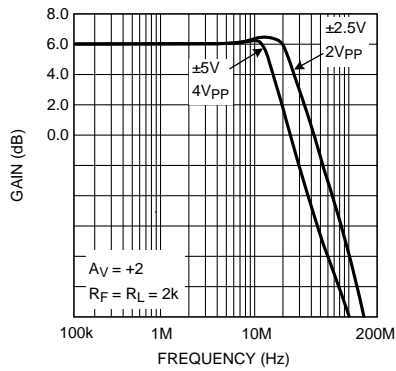

Figure 7. Large Signal Frequency Response

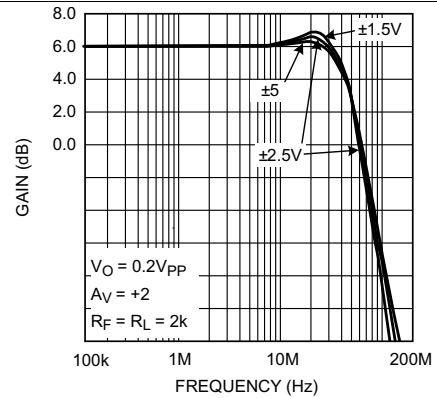

Figure 8. Closed Loop Small Signal Frequency Response for Various Supplies

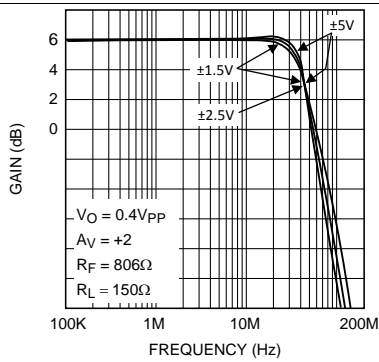

Figure 9. Closed Loop Frequency Response for Various Supplies

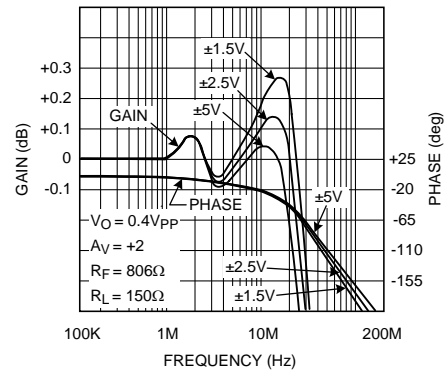

Figure 10. $\pm 0.1\text{dB}$ Gain Flatness for Various Supplies

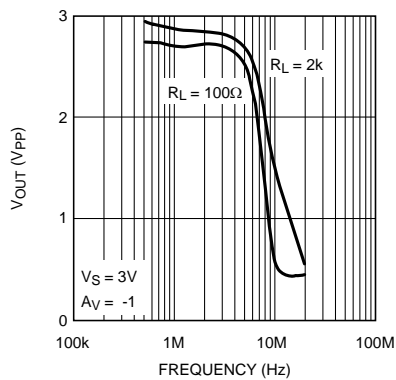

Figure 11. V_{OUT} (V_{PP}) for THD < 0.5%

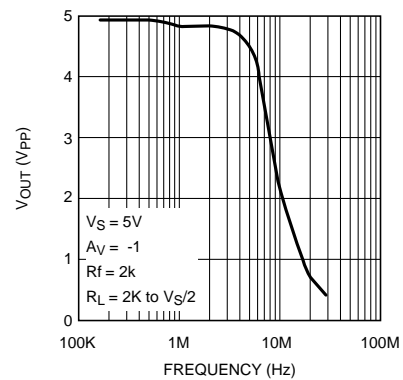

Figure 12. V_{OUT} (V_{PP}) for THD < 0.5%

Typical Performance Characteristics (continued)

$V^+ = +5\text{ V}$, $V^- = -5\text{ V}$, $R_f = R_L = 2\text{ k}\Omega$, unless specified otherwise.

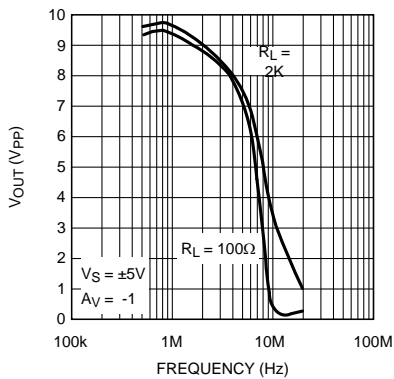

Figure 13. V_{OUT} (V_{pp}) for THD < 0.5%

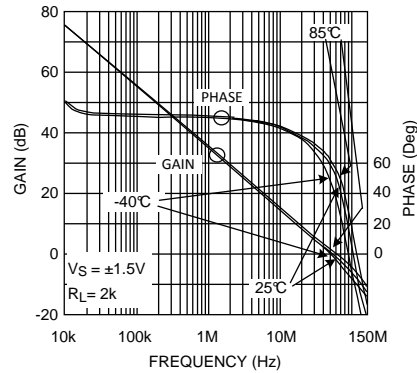

Figure 14. Open Loop Gain/Phase for Various Temperature

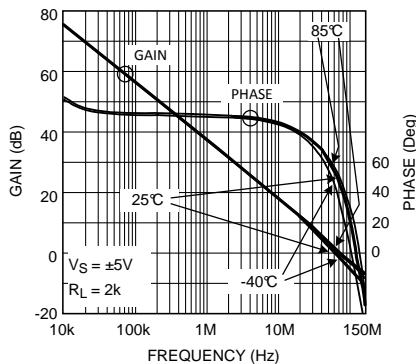

Figure 15. Open Loop Gain/Phase for Various Temperature

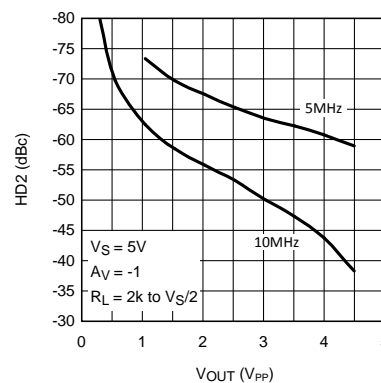

Figure 16. HD₂ (dBc) vs Output Swing

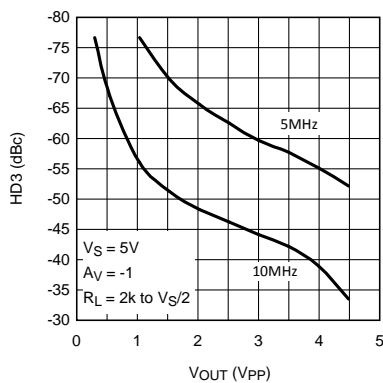

Figure 17. HD₃ (dBc) vs Output Swing

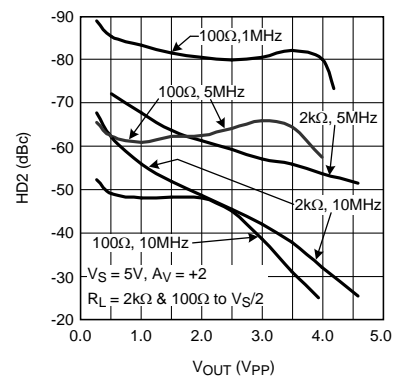

Figure 18. HD₂ vs Output Swing

Typical Performance Characteristics (continued)

$V^+ = +5\text{ V}$, $V^- = -5\text{ V}$, $R_f = R_L = 2\text{ k}\Omega$, unless specified otherwise.

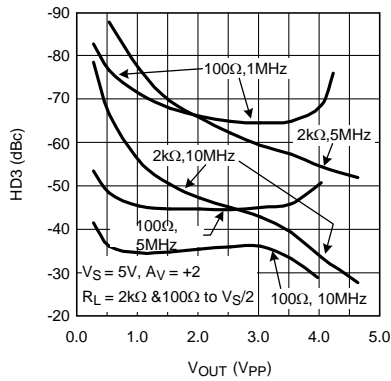

Figure 19. HD3 vs Output Swing

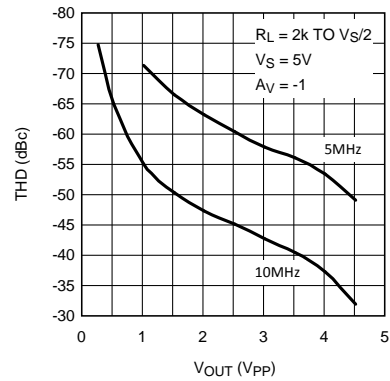

Figure 20. THD (dBc) vs Output Swing

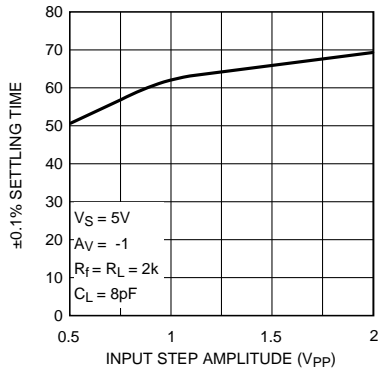

Figure 21. Settling Time vs Input Step Amplitude (Output Slew and Settle Time)

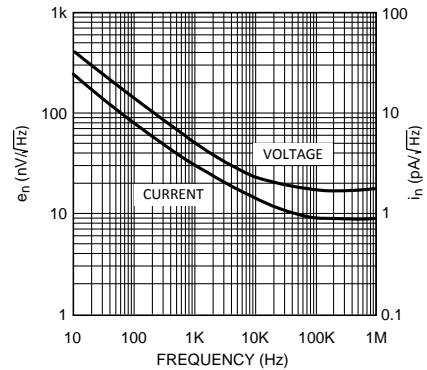

Figure 22. Input Noise vs Frequency

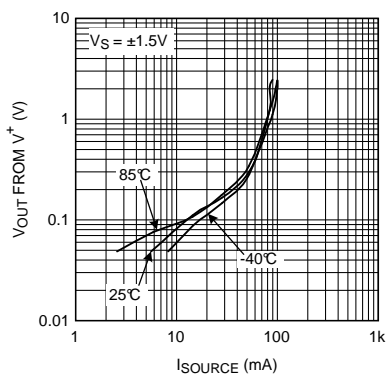

Figure 23. V_{OUT} from V^+ vs I_{SOURCE}

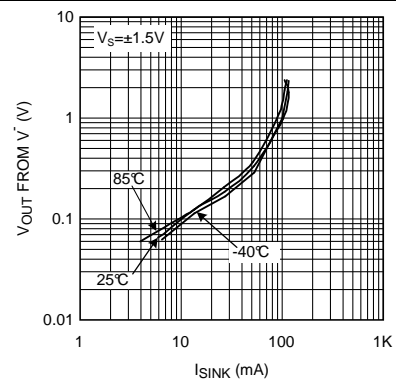

Figure 24. V_{OUT} from V^- vs I_{SINK}

Typical Performance Characteristics (continued)

$V^+ = +5\text{ V}$, $V^- = -5\text{ V}$, $R_f = R_L = 2\text{ k}\Omega$, unless specified otherwise.

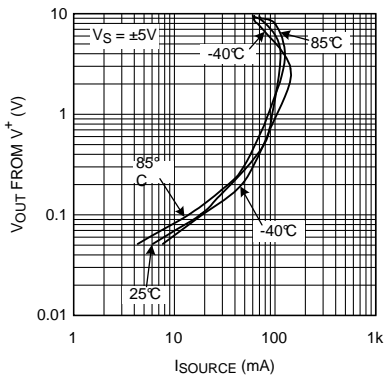

Figure 25. V_{OUT} from V^+ vs I_{SOURCE}

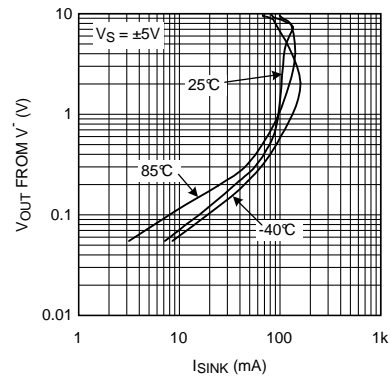

Figure 26. V_{OUT} from V^- vs I_{SINK}

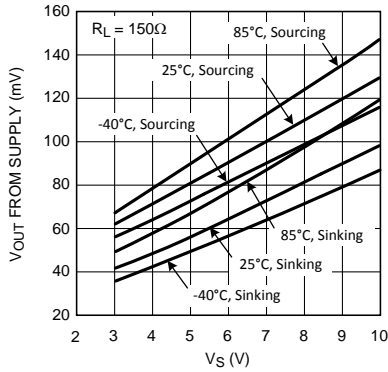

Figure 27. Swing vs V_S

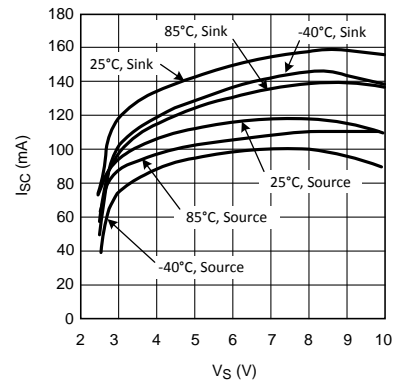

Figure 28. Short Circuit Current (to $V_S/2$) vs V_S

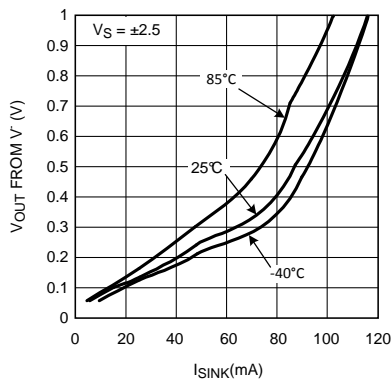

Figure 29. Output Sinking Saturation Voltage vs I_{OUT}

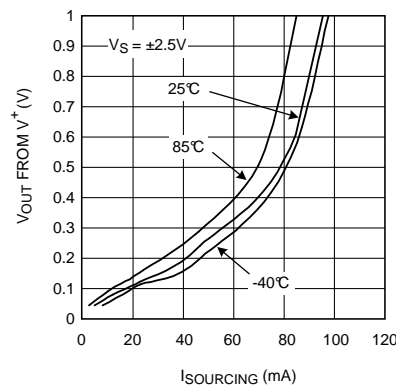

Figure 30. Output Sourcing Saturation Voltage vs I_{OUT}

Typical Performance Characteristics (continued)

$V^+ = +5\text{ V}$, $V^- = -5\text{ V}$, $R_F = R_L = 2\text{ k}\Omega$, unless specified otherwise.

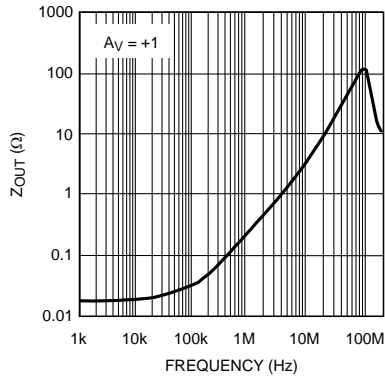

Figure 31. Closed Loop Output Impedance vs Frequency $A_V = +1$

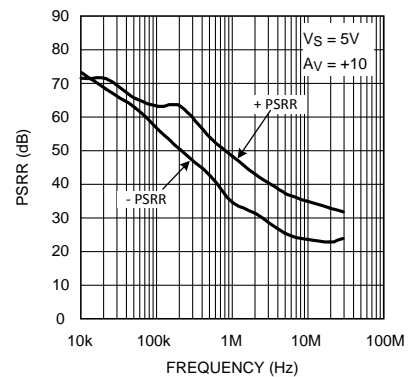

Figure 32. PSRR vs Frequency

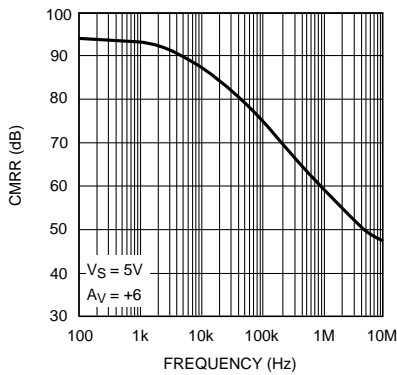

Figure 33. CMRR vs Frequency

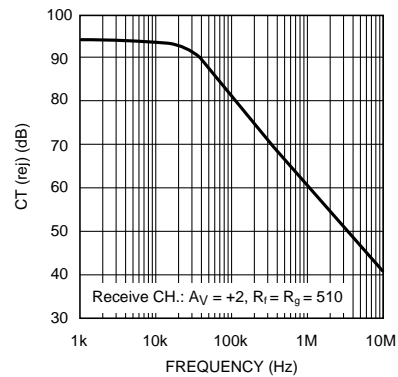

Figure 34. Crosstalk Rejection vs Frequency (Output to Output)

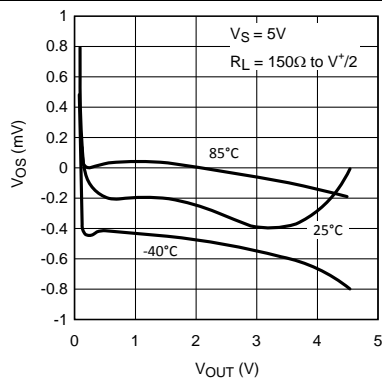

Figure 35. V_{OS} vs V_{OUT} (Typical Unit)

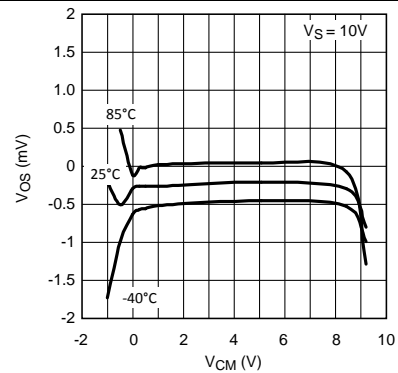

Figure 36. V_{OS} vs V_{CM} (Typical Unit)

Typical Performance Characteristics (continued)

$V^+ = +5\text{ V}$, $V^- = -5\text{ V}$, $R_F = R_L = 2\text{ k}\Omega$, unless specified otherwise.

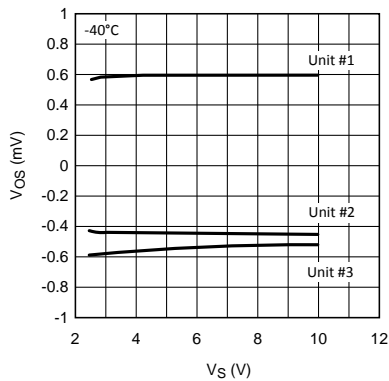

Figure 37. V_{OS} vs V_S (for 3 Representative Units)

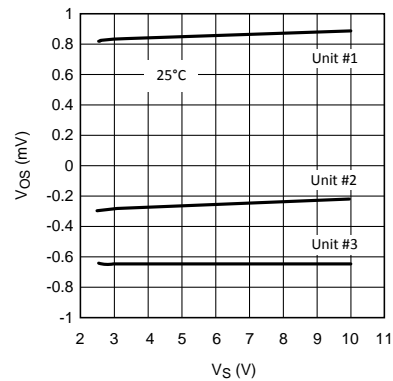

Figure 38. V_{OS} vs V_S (for 3 Representative Units)

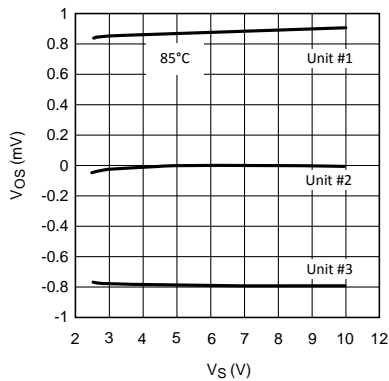

Figure 39. V_{OS} vs V_S (for 3 Representative Units)

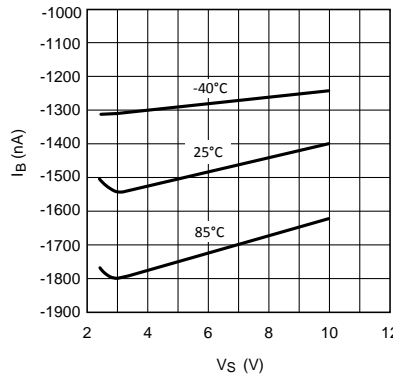

Figure 40. I_B vs V_S

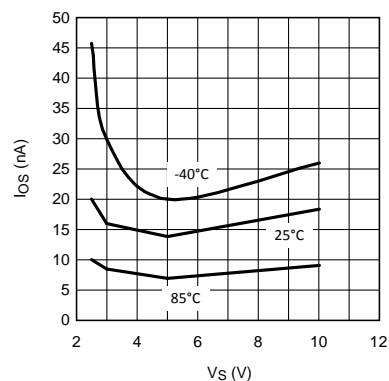

Figure 41. I_{OS} vs V_S

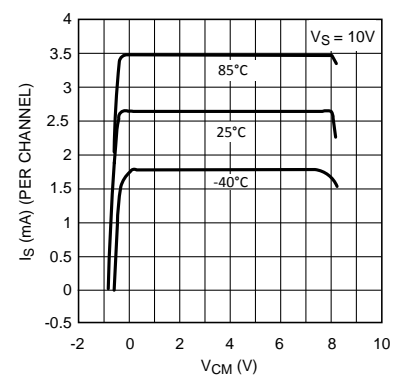

Figure 42. I_S vs V_{CM}

Typical Performance Characteristics (continued)

$V^+ = +5\text{ V}$, $V^- = -5\text{ V}$, $R_f = R_L = 2\text{ k}\Omega$, unless specified otherwise.

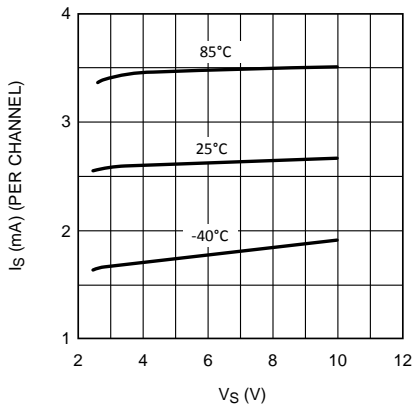

Figure 43. I_S vs V_S

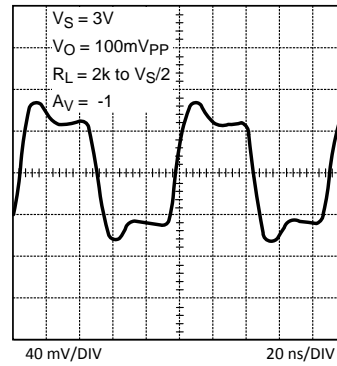

Figure 44. Small Signal Step Response

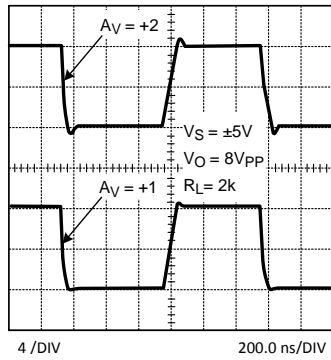

Figure 45. Large Signal Step Response

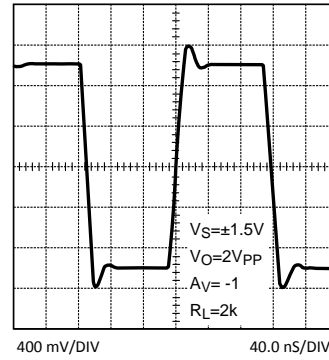

Figure 46. Large Signal Step Response

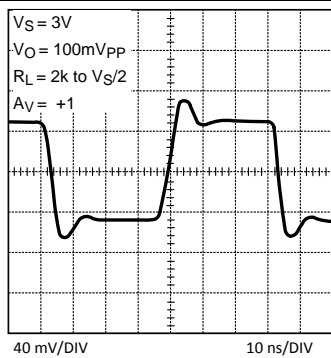

Figure 47. Small Signal Step Response

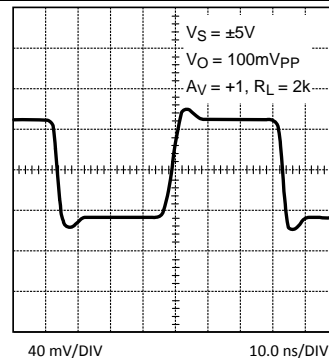

Figure 48. Small Signal Step Response

Typical Performance Characteristics (continued)

$V^+ = +5\text{ V}$, $V^- = -5\text{ V}$, $R_F = R_L = 2\text{ k}\Omega$, unless specified otherwise.

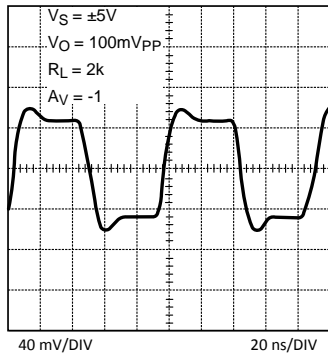

Figure 49. Small Signal Step Response

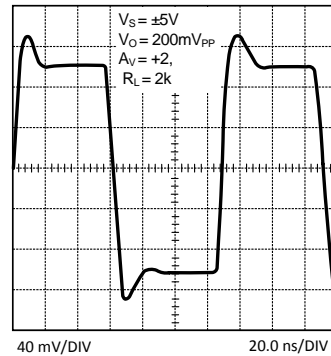

Figure 50. Small Signal Step Response

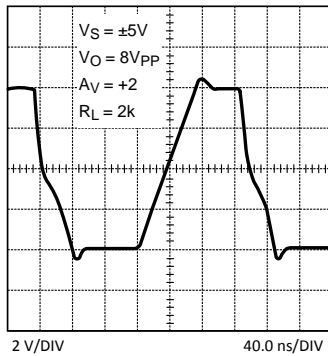

Figure 51. Large Signal Step Response

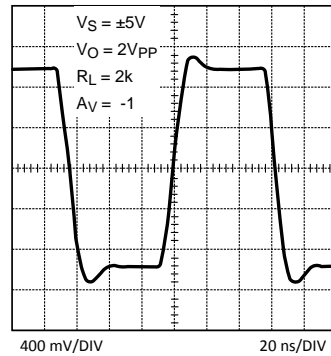

Figure 52. Large Signal Step Response

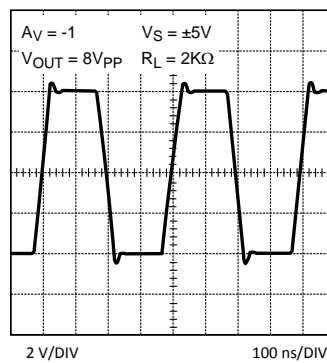

Figure 53. Large Signal Step Response

8 Detailed Description

8.1 Overview

The LMH6644-MIL is based on proprietary VIP10 dielectrically isolated bipolar process. This device architecture features the following:

- Complimentary bipolar devices with exceptionally high f_t (~8 GHz) even under low-supply voltage (2.7 V) and low-bias current.
- A class A-B *turn-around* stage with improved noise, offset, and reduced power dissipation compared to similar speed devices (patent pending).
- Common Emitter push-push output stage capable of 75-mA output current (at 0.5 V from the supply rails) while consuming only 2.7 mA of total supply current per channel. This architecture allows output to reach within mV of either supply rail.
- Consistent performance over the entire operating supply voltage range with little variation for the most important specifications (for example, BW, SR, I_{OUT} , and so forth)
- Significant power saving (~40%) compared to competitive devices on the market with similar performance.

8.2 Functional Block Diagram

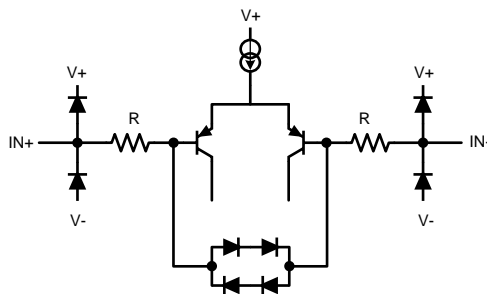

Figure 54. Input Equivalent Circuit

8.3 Feature Description

The LMH6644-MIL is a drop-in replacement for the AD805X family of high-speed op amps in most applications. In addition, the LMH6644-MIL will typically save about 40% on power dissipation, due to lower supply current, when compared to competition. All AD805X family's specified parameters are included in the list of LMH6644-MIL ensured specifications in order to ensure equal or better level of performance. However, as in most high-performance parts and due to subtleties of applications, it is strongly recommended that the performance of the part to be evaluated is tested under actual operating conditions to ensure full compliance to all specifications.

8.4 Device Functional Modes

With 3-V supplies and a common-mode input voltage range that extends 0.5 V below V^- , the LMH6644-MIL find applications in low voltage/low power applications. Even with 3-V supplies, the -3dB BW (@ $A_V = +1$) is typically 115 MHz with a tested limit of 80 MHz. Production testing guarantees that process variations will not compromise speed. High-frequency response is exceptionally stable, confining the typical -3dB BW over the industrial temperature range to $\pm 2.5\%$.

As seen in *Typical Performance Characteristics*, the LMH6644-MIL output current capability (~75 mA) is enhanced compared to AD805X. This enhancement increases the output load range, adding to the LMH6644-MIL's versatility. Since LMH6644-MIL is capable of high-output current, device junction temperature should not to exceed the Absolute Maximum Ratings.

9 Application and Implementation

NOTE

Information in the following applications sections is not part of the TI component specification, and TI does not warrant its accuracy or completeness. TI's customers are responsible for determining suitability of components for their purposes. Customers should validate and test their design implementation to confirm system functionality.

9.1 Application Information

This device was designed to avoid output phase reversal. With input overdrive, the output is kept near supply rail (or as closed to it as mandated by the closed loop gain setting and the input voltage). See [Figure 56](#).

However, if the input voltage range of -0.5 V to 1 V from V^+ is exceeded by more than a diode drop, the internal ESD protection diodes will start to conduct. The current in the diodes should be kept at or below 10 mA .

Output overdrive recovery time is less than 100 ns as can be seen in [Figure 57](#).

9.2 Typical Application

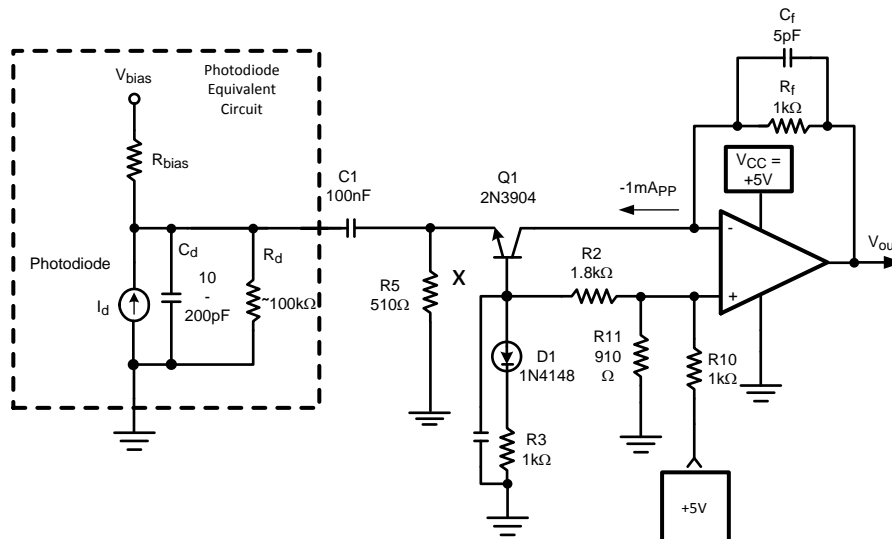

Figure 55. Single-Supply Photodiode I-V Converter

9.2.1 Design Requirements

The circuit shown in [Figure 55](#) is used to amplify the current from a photodiode into a voltage output. In this circuit, the emphasis is on achieving high bandwidth and the transimpedance gain setting is kept relatively low. Because of its high-slew-rate limit and high speed, the LMH6644-MIL lends itself well to such an application. This circuit achieves approximately 1 V/mA of transimpedance gain and capable of handling up to 1 mA_{App} from the photodiode. Q1, in a common base configuration, isolates the high capacitance of the photodiode (C_d) from the op amp input in order to maximize speed. Input is AC coupled through C1 to ease biasing and allow single supply operation. With 5-V single supply, the device input/output is shifted to near half supply using a voltage divider from VCC. Note that Q1 collector does not have any voltage swing and the Miller effect is minimized. D1, tied to Q1 base, is for temperature compensation of Q1's bias point. Q1 collector current was set to be large enough to handle the peak-to-peak photodiode excitation and not too large to shift the U1 output too far from mid-supply.

Typical Application (continued)

9.2.1.1 Input and Output Topology

All input / output pins are protected against excessive voltages by ESD diodes connected to V^+ and V^- rails (see [Figure 54](#)). These diodes start conducting when the input / output pin voltage approaches $1 V_{be}$ beyond V^+ or V^- to protect against over voltage. These diodes are normally reverse biased. Further protection of the inputs is provided by the two resistors (R in [Figure 54](#)), in conjunction with the string of anti-parallel diodes connected between both bases of the input stage. The combination of these resistors and diodes reduces excessive differential input voltages approaching $2 V_{be}$. This occurs most commonly when the device is used as a comparator (or with little or no feedback) and the device inputs no longer follow each other. In such a case, the diodes may conduct. As a consequence, input current increases and the differential input voltage is clamped. It is important to make sure that the subsequent current flow through the device input pins does not violate the Absolute Maximum Ratings of the device. To limit the current through this protection circuit, extra series resistors can be placed. Together with the built-in series resistors of several hundred ohms, these external resistors can limit the input current to a safe number (that is, less than 10 mA). Be aware that these input series resistors may impact the switching speed of the device and could slow down the device.

9.2.1.2 Single-Supply, Low-Power Photodiode Amplifier

The circuit shown in [Figure 55](#) is used to amplify the current from a photodiode into a voltage output. In this circuit, the emphasis is on achieving high bandwidth and the transimpedance gain setting is kept relatively low. Because of its high slew rate limit and high speed, the LMH6644-MIL lends itself well to such an application.

This circuit achieves approximately 1V/mA of transimpedance gain and capable of handling up to $1mA_{pp}$ from the photodiode. Q1, in a common base configuration, isolates the high capacitance of the photodiode (C_d) from the Op Amp input in order to maximize speed. Input is AC coupled through C1 to ease biasing and allow single-supply operation. With 5-V single supply, the device input/output is shifted to near half supply using a voltage divider from V_{CC} . Note that Q1 collector does not have any voltage swing and the Miller effect is minimized. D1, tied to Q1 base, is for temperature compensation of Q1's bias point. Q1 collector current was set to be large enough to handle the peak-to-peak photodiode excitation and not too large to shift the U1 output too far from mid-supply.

No matter how low an R_f is selected, there is a need for C_f in order to stabilize the circuit. The reason for this is that the Op Amp input capacitance and Q1 equivalent collector capacitance together (C_{IN}) will cause additional phase shift to the signal fed back to the inverting node. C_f will function as a zero in the feedback path counteracting the effect of the C_{IN} and acting to stabilize the circuit. By proper selection of C_f such that the Op Amp open loop gain is equal to the inverse of the feedback factor at that frequency, the response is optimized with a theoretical 45° phase margin.

$$C_F = \sim \text{SQRT} \left[\frac{C_{IN}}{(2\pi \cdot \text{GBWP} \cdot R_F)} \right]$$

where

- GBWP is the Gain Bandwidth Product of the Op Amp (1)

Optimized as such, the I-V converter will have a theoretical pole, f_p , at:

$$f_p = \text{SQRT} \left[\frac{\text{GBWP}}{(2\pi R_F \cdot C_{IN})} \right] \quad (2)$$

With op amp input capacitance of 3 pF and an estimate for Q1 output capacitance of about 3 pF as well, $C_{IN} = 6$ pF. From the typical performance plots, GBWP is approximately 57 MHz. Therefore, with $R_f = 1k$, from [Equation 1](#) and [Equation 2](#):

$$C_f = \sim 4.1 \text{ pF and } f_p = 39 \text{ MHz} \quad (3)$$

For this example, optimum C_f was empirically determined to be around 5 pF. This time domain response is shown in [Figure 58](#) below showing about 9-ns rise/fall times, corresponding to about 39 MHz for f_p . The overall supply current from the +5 V supply is around 5 mA with no load.

Typical Application (continued)

9.2.2 Detailed Design Procedure

No matter how low an R_f is selected, there is a need for C_f in order to stabilize the circuit. The reason for this is that the op amp input capacitance and Q1 equivalent collector capacitance together (C_{IN}) will cause additional phase shift to the signal fed back to the inverting node. C_f will function as a zero in the feedback path counteracting the effect of the C_{IN} and acting to stabilize the circuit. By proper selection of C_f such that the Op Amp open loop gain is equal to the inverse of the feedback factor at that frequency, the response is optimized with a theoretical 45° phase margin where GBWP is the Gain Bandwidth Product of the Op Amp, optimized as such, the I-V converter will have a theoretical pole, f_p , at: (2) With Op Amp input capacitance of 3pF and an estimate for Q1 output capacitance of about 3 pF as well, $C_{IN} = 6$ pF. From the typical performance plots, GBWP is approximately 57 MHz. Therefore, with $R_f = 1k$, from Equation 2 and Equation 3 : $C_f = \sim 4.1$ pF and $f_p = 39$ MHz.

For this example, optimum C_f was empirically determined to be around 5 pF. This time domain response is shown in Figure 58 showing about 9 ns rise/fall times, corresponding to about 39 MHz for f_p . The overall supply current from the +5-V supply is around 5 mA with no load.

9.2.3 Application Curves

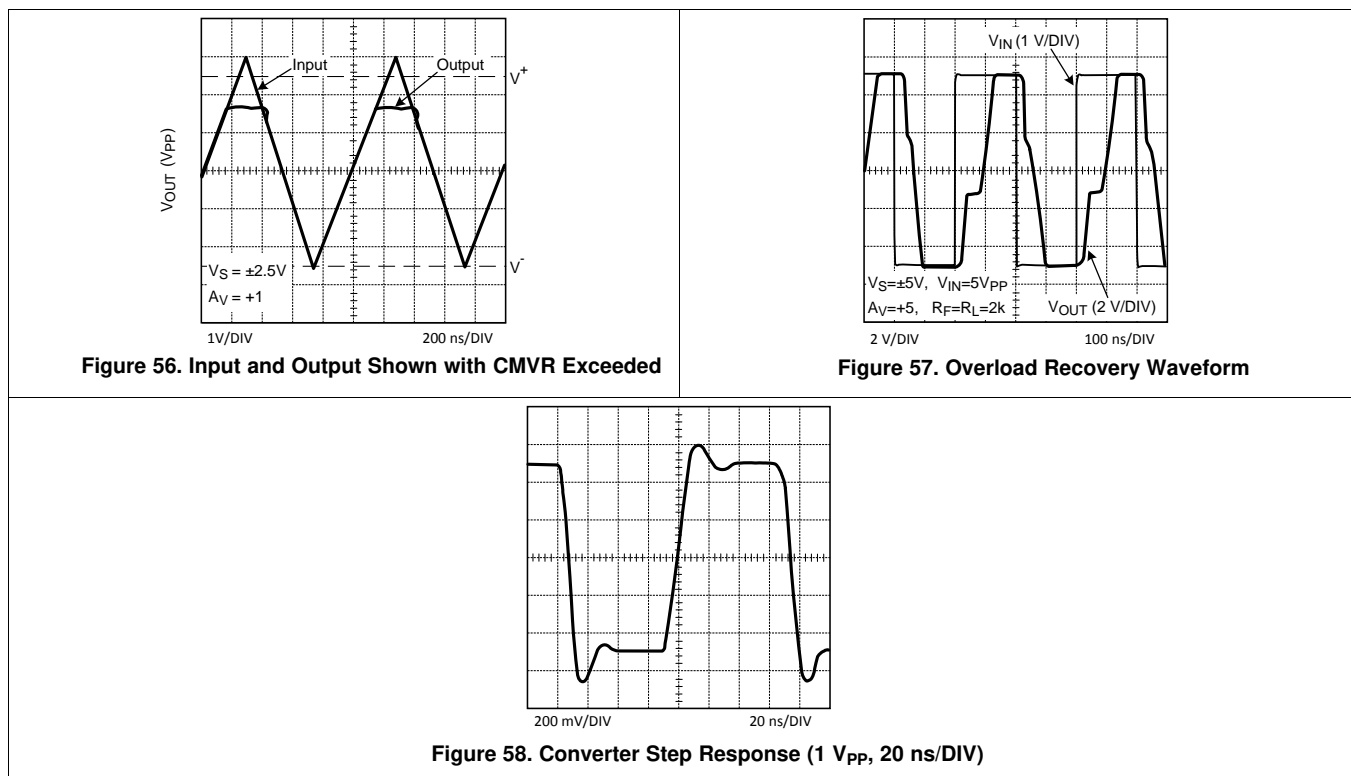

10 Power Supply Recommendations

The LMH6644-MIL device can operate off a single supply or with dual supplies. The input CM capability of the parts (CMVR) extends all the way down to the $V-$ rail to simplify single supply applications. Supplies should be decoupled with low inductance, often ceramic, capacitors to ground less than 0.5 inches from the device pins. The use of ground plane is recommended, and as in most high speed devices, it is advisable to remove ground plane close to device sensitive pins such as the inputs.

12 Device and Documentation Support

12.1 Receiving Notification of Documentation Updates

To receive notification of documentation updates, navigate to the device product folder on ti.com. In the upper right corner, click on *Alert me* to register and receive a weekly digest of any product information that has changed. For change details, review the revision history included in any revised document.

12.2 Community Resources

The following links connect to TI community resources. Linked contents are provided "AS IS" by the respective contributors. They do not constitute TI specifications and do not necessarily reflect TI's views; see TI's [Terms of Use](#).

TI E2E™ Online Community *TI's Engineer-to-Engineer (E2E) Community*. Created to foster collaboration among engineers. At e2e.ti.com, you can ask questions, share knowledge, explore ideas and help solve problems with fellow engineers.

Design Support *TI's Design Support* Quickly find helpful E2E forums along with design support tools and contact information for technical support.

12.3 Trademarks

E2E is a trademark of Texas Instruments.
All other trademarks are the property of their respective owners.

12.4 Electrostatic Discharge Caution



These devices have limited built-in ESD protection. The leads should be shorted together or the device placed in conductive foam during storage or handling to prevent electrostatic damage to the MOS gates.

12.5 Glossary

[SLYZ022](#) — *TI Glossary*.

This glossary lists and explains terms, acronyms, and definitions.

13 Mechanical, Packaging, and Orderable Information

The following pages include mechanical, packaging, and orderable information. This information is the most current data available for the designated devices. This data is subject to change without notice and revision of this document. For browser-based versions of this data sheet, refer to the left-hand navigation.

PACKAGING INFORMATION

Orderable Device	Status (1)	Package Type	Package Drawing	Pins	Package Qty	Eco Plan (2)	Lead finish/ Ball material (6)	MSL Peak Temp (3)	Op Temp (°C)	Device Marking (4/5)	Samples
LMH6644 MDC	ACTIVE	DIESALE	Y	0	100	RoHS & Green	Call TI	Level-1-NA-UNLIM	-40 to 85		Samples

(1) The marketing status values are defined as follows:

ACTIVE: Product device recommended for new designs.

LIFEBUY: TI has announced that the device will be discontinued, and a lifetime-buy period is in effect.

NRND: Not recommended for new designs. Device is in production to support existing customers, but TI does not recommend using this part in a new design.

PREVIEW: Device has been announced but is not in production. Samples may or may not be available.

OBSOLETE: TI has discontinued the production of the device.

(2) **RoHS:** TI defines "RoHS" to mean semiconductor products that are compliant with the current EU RoHS requirements for all 10 RoHS substances, including the requirement that RoHS substance do not exceed 0.1% by weight in homogeneous materials. Where designed to be soldered at high temperatures, "RoHS" products are suitable for use in specified lead-free processes. TI may reference these types of products as "Pb-Free".

RoHS Exempt: TI defines "RoHS Exempt" to mean products that contain lead but are compliant with EU RoHS pursuant to a specific EU RoHS exemption.

Green: TI defines "Green" to mean the content of Chlorine (Cl) and Bromine (Br) based flame retardants meet JS709B low halogen requirements of <=1000ppm threshold. Antimony trioxide based flame retardants must also meet the <=1000ppm threshold requirement.

(3) MSL, Peak Temp. - The Moisture Sensitivity Level rating according to the JEDEC industry standard classifications, and peak solder temperature.

(4) There may be additional marking, which relates to the logo, the lot trace code information, or the environmental category on the device.

(5) Multiple Device Markings will be inside parentheses. Only one Device Marking contained in parentheses and separated by a "-" will appear on a device. If a line is indented then it is a continuation of the previous line and the two combined represent the entire Device Marking for that device.

(6) Lead finish/Ball material - Orderable Devices may have multiple material finish options. Finish options are separated by a vertical ruled line. Lead finish/Ball material values may wrap to two lines if the finish value exceeds the maximum column width.

Important Information and Disclaimer: The information provided on this page represents TI's knowledge and belief as of the date that it is provided. TI bases its knowledge and belief on information provided by third parties, and makes no representation or warranty as to the accuracy of such information. Efforts are underway to better integrate information from third parties. TI has taken and continues to take reasonable steps to provide representative and accurate information but may not have conducted destructive testing or chemical analysis on incoming materials and chemicals. TI and TI suppliers consider certain information to be proprietary, and thus CAS numbers and other limited information may not be available for release.

In no event shall TI's liability arising out of such information exceed the total purchase price of the TI part(s) at issue in this document sold by TI to Customer on an annual basis.

IMPORTANT NOTICE AND DISCLAIMER

TI PROVIDES TECHNICAL AND RELIABILITY DATA (INCLUDING DATASHEETS), DESIGN RESOURCES (INCLUDING REFERENCE DESIGNS), APPLICATION OR OTHER DESIGN ADVICE, WEB TOOLS, SAFETY INFORMATION, AND OTHER RESOURCES "AS IS" AND WITH ALL FAULTS, AND DISCLAIMS ALL WARRANTIES, EXPRESS AND IMPLIED, INCLUDING WITHOUT LIMITATION ANY IMPLIED WARRANTIES OF MERCHANTABILITY, FITNESS FOR A PARTICULAR PURPOSE OR NON-INFRINGEMENT OF THIRD PARTY INTELLECTUAL PROPERTY RIGHTS.

These resources are intended for skilled developers designing with TI products. You are solely responsible for (1) selecting the appropriate TI products for your application, (2) designing, validating and testing your application, and (3) ensuring your application meets applicable standards, and any other safety, security, or other requirements. These resources are subject to change without notice. TI grants you permission to use these resources only for development of an application that uses the TI products described in the resource. Other reproduction and display of these resources is prohibited. No license is granted to any other TI intellectual property right or to any third party intellectual property right. TI disclaims responsibility for, and you will fully indemnify TI and its representatives against, any claims, damages, costs, losses, and liabilities arising out of your use of these resources.

TI's products are provided subject to TI's Terms of Sale (www.ti.com/legal/termsofsale.html) or other applicable terms available either on ti.com or provided in conjunction with such TI products. TI's provision of these resources does not expand or otherwise alter TI's applicable warranties or warranty disclaimers for TI products.

Mailing Address: Texas Instruments, Post Office Box 655303, Dallas, Texas 75265
Copyright © 2020, Texas Instruments Incorporated