

MATERIALS & SPECIFICATIONS

PART NO.	A29051-009	REV	ECO	DATE	05-04-16	APP	TLM
		B	102559				

- HOUSING:**
ALUMINUM 6061-T6, NICKEL PLATE PER SAE-AMS-2404
- INSULATOR:**
LIQUID CRYSTAL POLYMER (LCP) PER ASTM D5138
- CONTACTS:**
COPPER ALLOY PER MIL-DTL-32139, GOLD PLATED PER ASTM B488, (HARD GOLD) TYPE II CODE C CLASS 1.27
- TERMINATIONS:**
SOLDER COATED WITH SN63A PER J-STD-006
- CURRENT RATING:**
1 AMP MAX PER MIL-DTL-32139
- CONTACT RESISTANCE:**
71 MILLIOHM MAX (71mV DROP MAX) @ 1.0 AMPS PER MIL-DTL-32139

PERFORMANCE:
PRODUCT FAMILY TESTED TO AND PASSED THE PERFORMANCE SPECIFICATIONS OF TABLE VIII OF MIL-DTL-32139

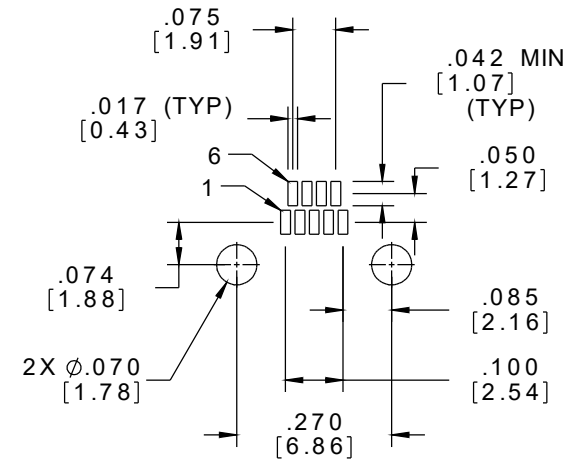
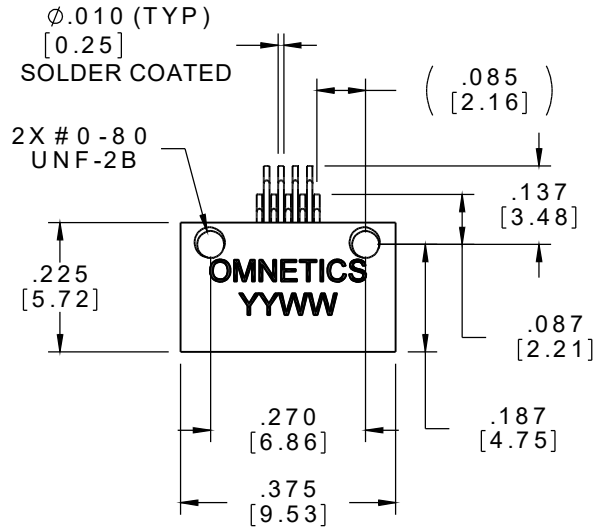

SUGGESTED PAD LAYOUT

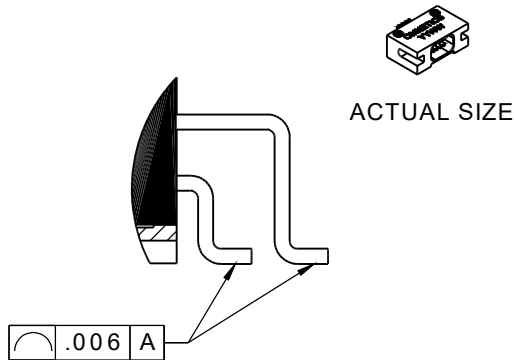

DETAIL B
SCALE 8 : 1

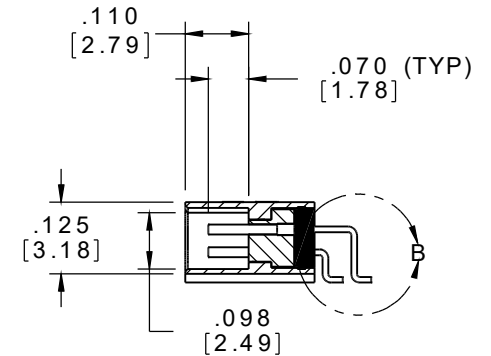
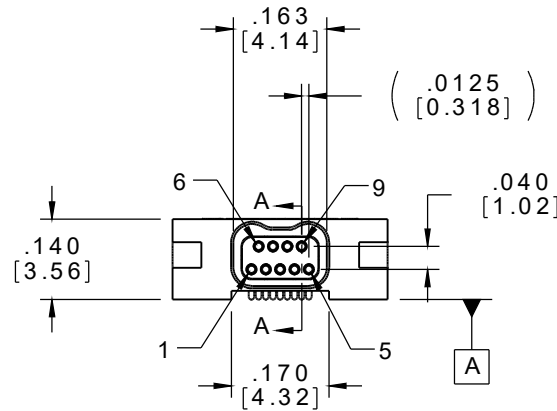

SECTION A-A

NOTE:

DIMENSIONS IN [] ARE IN MILLIMETERS UNLESS OTHERWISE NOTED AND ARE FOR REFERENCE ONLY

MNSI SLDW	THIRD ANGLE	THIS DRAWING CONTAINS CONFIDENTIAL AND PROPRIETARY INFORMATION WHICH IS THE PROPERTY OF OMNETICS CONNECTOR CORPORATION. THIS DOCUMENT MAY NOT, IN WHOLE OR IN PART, BE DUPLICATED, OR DISCLOSED FOR ANY PURPOSE, WITHOUT WRITTEN PERMISSION FROM OMNETICS CONNECTOR CORP.	
	-TOLERANCES- UNLESS OTHERWISE NOTED DIMENSIONS IN INCHES	DFTM. TLM	DATE 04-29-15
	2 PL DEC ± .01	CHK'D.	DATE
	3 PL DEC ± .005	APP'D.	DATE
	4 PL DEC ± .0005		
	ANGLES ± 1°		

OMNETICS
CONNECTOR CORPORATION
7260 COMMERCE CIRCLE EAST
MINNEAPOLIS, MN 55432
WWW.OMNETICS.COM

CAGE CODE 61873	
DWG NO. A29051-009	
SHEET 1 OF 1	REV B
SCALE: 3:1	