



specification: imp002

version 20150716

1. Product description

1.1 General description

The imp is a complete wireless network node in a module. It is available both in a memory card form-factor (imp001) and in a solder-down module form-factor (imp002). It works in conjunction with the imp service to allow easy connection of any device to the internet. There are two versions of imp002; the imp002-s uses the built-in antenna and the imp002-c uses an external antenna. This document covers specifications for both versions of the imp002.

1.2 Features

- 802.11 b/g/n WiFi
 - 20MHz 11n channels, 1 x 1
 - -97dBm typical sensitivity (1Mbps)
 - Integrated antenna with 2.5dBi max gain
 - TX power
 - 802.11b 16.5dBm +/-1.5dBm
 - 802.11g 14.0dBm +/-1.5dBm
 - 802.11n 12.75dBm +/-1.5dBm
- 32-bit Cortex M3 processor
 - Robust embedded operating system with fail-safe firmware updates
 - Virtual machine for vendor firmware
- LED drive for red/green status LEDs
- Phototransistor input for our patent-pending BlinkUp technology to provide optical configuration
- 12 user selectable I/Os
 - GPIO, PWM, Analog input & output
 - SPI (2 channels), UART (4.5 channels), I2C (2 channels)
- Low power 6uA sleep mode
- FCC, CE, IC C-Tick modular certification

Ordering information

Part number	Description
imp002-s-us-tr	imp module with built-in antenna, US/CAN version, tape & reel
imp002-s-eu-tr	imp module with built-in antenna, EU/AUS/NZ version, tape & reel
imp002-c-us-tr	imp module which uses external antenna, US/CAN version, tape & reel
imp002-c-eu-tr	imp module which uses external antenna, EU/AUS/NZ version, tape & reel

imp002 is rated at MSL 3

2. Imp terminology

Term	Description
Electric Imp	http://electricimp.com/aboutus/
API	The Application Programming Interface through which imp scripts may access hardware and cloud functions
BlinkUp	Our patent-pending optical programming process for commissioning an imp using a smart device (phone or tablet)
Commissioning	Initializing an imp by associating it with a user account and WiFi credentials, usually via BlinkUp
Blessing	The process by which an imp card or module becomes associated with host hardware
Server	The electric imp cloud service with which imps communicate
Firmware	User-defined code that runs within a virtual machine. Device Firmware runs on the Electric Imp Hardware. Agent Firmware runs in the Electric Imp Cloud.
Agent	A virtual machine within the Electric Imp Cloud. Each Electric Imp device is paired with exactly one Agent.
IDE	Integrated Development Environment. Used to develop and maintain your Electric Imp Firmware. Push new code to devices from any place at any time.
Ops Console	Gain more insight into your factory production lines and scale to millions of devices

3. Pin assignments

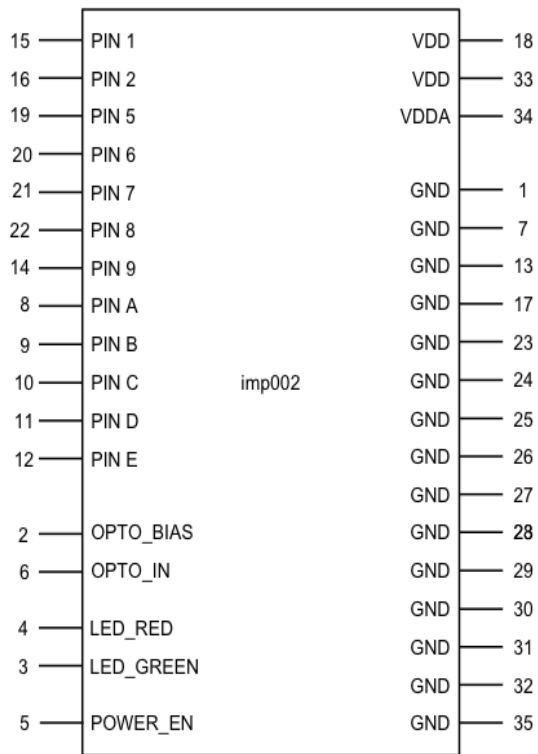

4. Pin description

Pin number	Pin Name	Description
1, 7, 13, 17, 23–32, 35	GND1 to 15	Ground
18, 33	V _{DD}	Power Input
2	OPTO_BIAS	Phototransistor power; connects to collector of phototransistor
6	OPTO_IN	Phototransistor signal; connects to emitter of phototransistor, which is connected to ground with a bias resistor
3	LED_GREEN	Green LED Output
4	LED_RED	Red LED Output
5	POWER_EN	Active-high output for boost DC/DC enable. POWER_EN is driven high when the module requires a 2.5-3.3V power supply, which is typically when WiFi is active. This pin has an internal pulldown while the imp is awake, which is disabled when the imp enters deep sleep. If this pin will be used while the imp is in deep sleep, an external pull-down is required.
34	V _{DDA}	ADC reference voltage input. If unused, connect to V _{DD}

8-12, 14-16, 19-22	Pin1, Pin2, Pin5-PinE	I/O, please refer to Pin mux table
--------------------	-----------------------	------------------------------------

4. LED drive

The indicator LED should be bicolor, because red, green and amber (red+green) are used to indicate status.

The LED drive pins will auto-detect common anode or common cathode parts. The detection is done by looking to see which way up the LED_RED pin is idling at boot; to ensure this works correctly, please place a 10kΩ resistor in parallel with the red LED.

The current drive on these pins is 20mA maximum.

Please refer to paragraph 12 for the recommended LEDs.

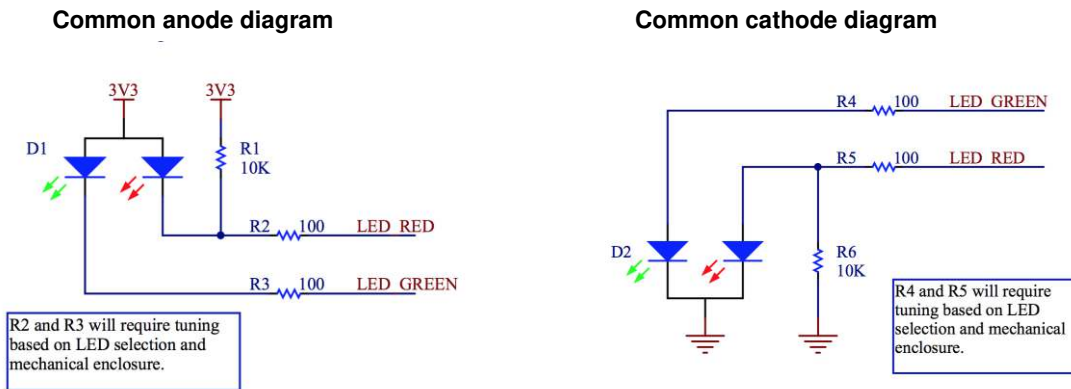

5. Phototransistor

The phototransistor is used to receive BlinkUp configuration data. The bias resistor connected between OPTO_IN and GND may need to be adjusted to ensure adequate sensitivity and response time - in general you need at least 500mV swing on the OPTO_IN pin between black and white states, with the worst (dimnest) BlinkUp sender you can find.

End-user BlinkUp send data at between 30 and 60 bits per second, depending on the user's device. For factory configuration, data is typically sent at 120 bits per second using red LED(s) in a test fixture. If your application does not require optical configuration, config can be sent electrically at 120 bits per second from another micro using the OPTO_IN pin. Please contact us for more details.

Please refer to paragraph 12 for the recommended phototransistors.

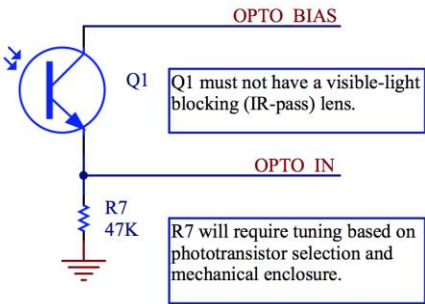

6. External antenna

The imp002-c is the version of imp002 that uses an external antenna. Please refer to paragraph 12 for the recommended antenna, which is used in our FCC approval.

7. Pin mux

In addition to acting as a GPIO, each pin on the imp002 can be configured to one of several specialized functions. While pins may only have one function at a time, they may be reconfigured during run-time to change function as needed. For example, a pin may first be configured as a DAC and then reconfigured as an ADC. Additionally, not all the pins in a hardware function need to be assigned to that function. For example, pins 8 and 9 could be used as UART and pins 1 and 2 could be used as I2C.

All I/O pins are initially tri-stated.

The imp002 can be woken from low power sleep mode with a rising edge on PIN1. If this signal is pulsed, the minimum pulse width is 20ms.

Pin	GPIO	UART	I2C	SPI	DAC	ADC	PWM	Pulse Count	Wake
PIN 1	Yes	U1-CTS, U3-TX	I1-SCL	SPI1-SCLK	Yes	Yes	Yes	Yes	Yes
PIN 2	Yes	U1-RTS, U3-RX	I1-SDA	SPI2-MISO		Yes	Yes		
PIN 5	Yes	U2-TX		SPI2-SCLK	Yes	Yes	Yes		
PIN 6	Yes	U6-TX							
PIN 7	Yes	U2-RX		SPI2-MOSI		Yes	Yes		
PIN 8	Yes	U1-TX	I2-SCL	SPI1-MOSI		Yes	Yes		
PIN 9	Yes	U1-RX	I2-SDA	SPI1-MISO		Yes	Yes		
PIN A	Yes					Yes			
PIN B	Yes	U4-RX				Yes			
PIN C	Yes						Yes		
PIN D	Yes								
PIN E	Yes	U6-RX							

8. Electrical characteristics

Parameter	Description	Min	Typ	Max	Unit.
Operating temperature		-20		55	°C
V _{DD}	Operating voltage	1.8 ^[1]	3.3	3.6	V
V _{DDA}	Analog power input	1.8	V _{DD}	V _{DD}	V
I _{DD}	Normal operation, WiFi on		80	250 ^[2]	mA
	Normal operation, WiFi power-save mode enabled		5	250 ^[2]	mA
	WiFi is off, processor sleep, RTC on, nvram preserved		6		µA
I _{DDA}	Current input on V _{DDA}		70	500	µA
V _{IH}	I/O input high level voltage	0.7V _{DD}		3.6	V
V _{IL}	I/O input low level voltage	V _{SS} -0.3		0.3V _{DD}	V
I _{OUT}	Output current on any single I/O pin	-8		8	mA
	Output current on LED_RED pin	-20		20	mA
	Output current on LED_GREEN pin	-20		20	mA
	Total output current on all I/O pins including LED_RED & LED_GREEN	-80		80	mA
I/O input leakage current	$V_{SS} \leq V_{IN} \leq V_{DD}$			4	µA
Load capacitance	Pins 1 to 9		20		pF
	Pins A to E		5		pF

[1] WiFi requires 2.5v minimum for operation, but user code can run at 1.8v. The POWER_EN pin is driven to enable an external boost converter that will provide 2.5v+ during WiFi usage.

[2] 250mA current is during worst-case TX events. These are a maximum of ~4.8ms long (802.11b 1Mbps)

9. Typical Application Circuit

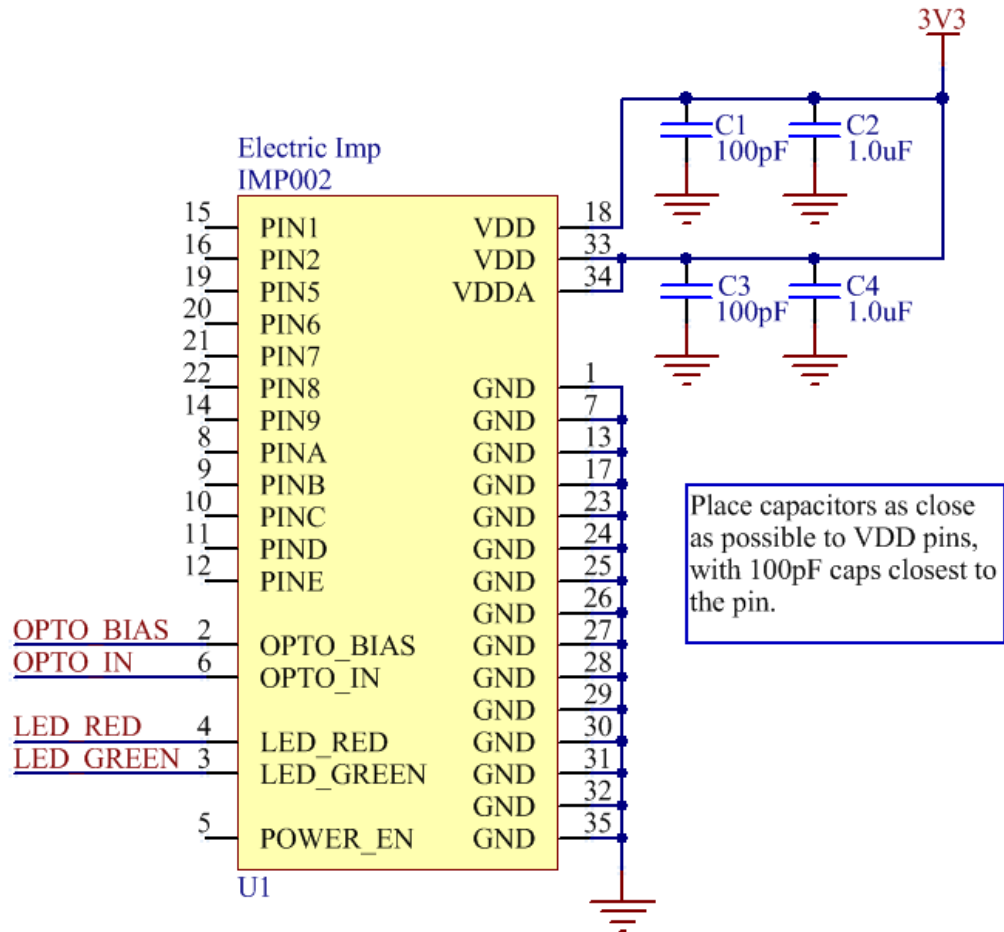

10. Package outline

PCB dimensions

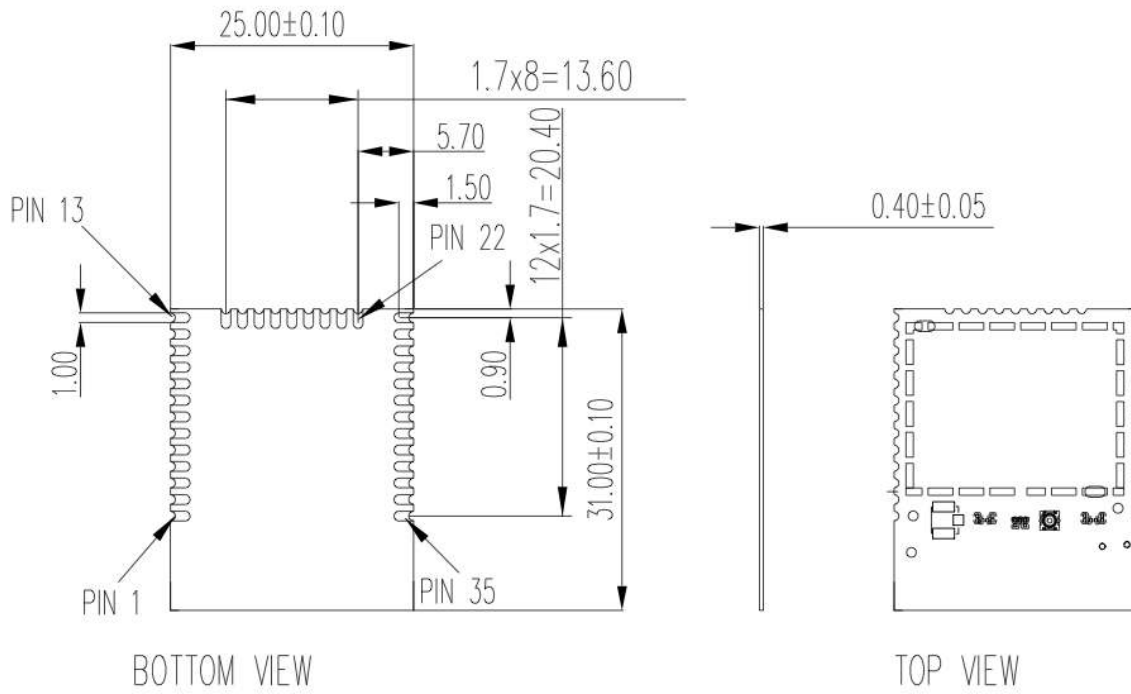

(all dimensions are in mm unless otherwise specified)

Overall module dimensions

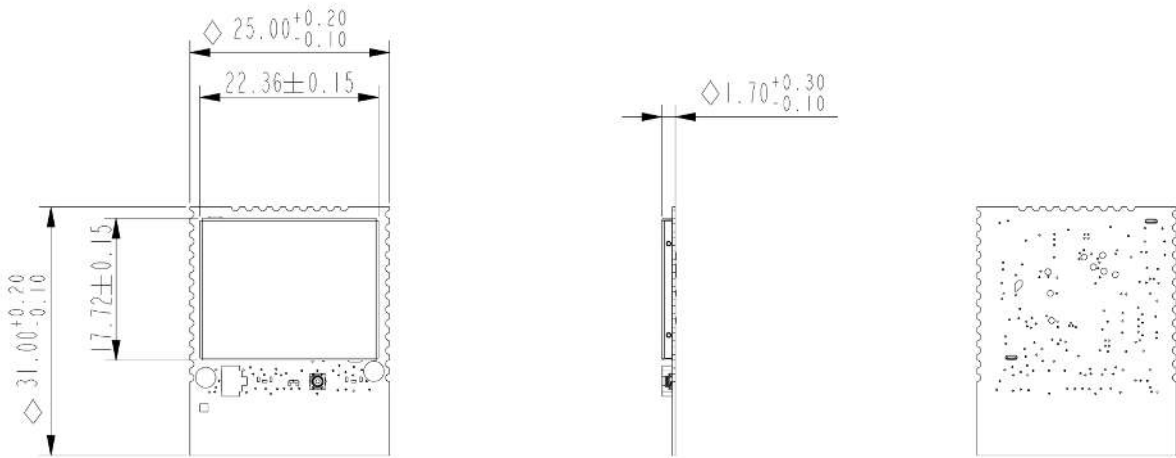

(all dimensions are in mm unless otherwise specified)

Tape & reel dimensions

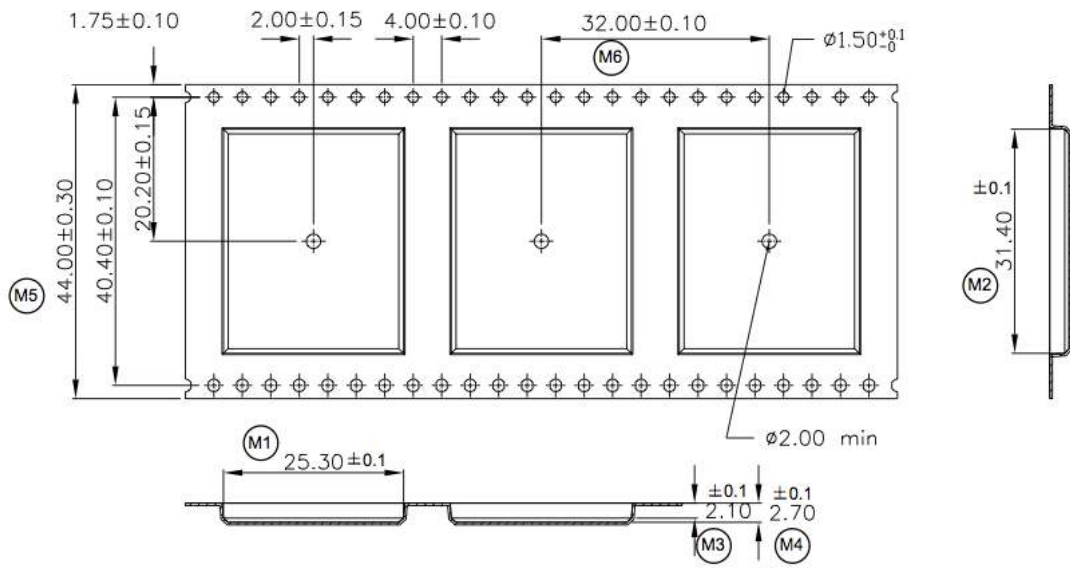

Reel disk dimensions

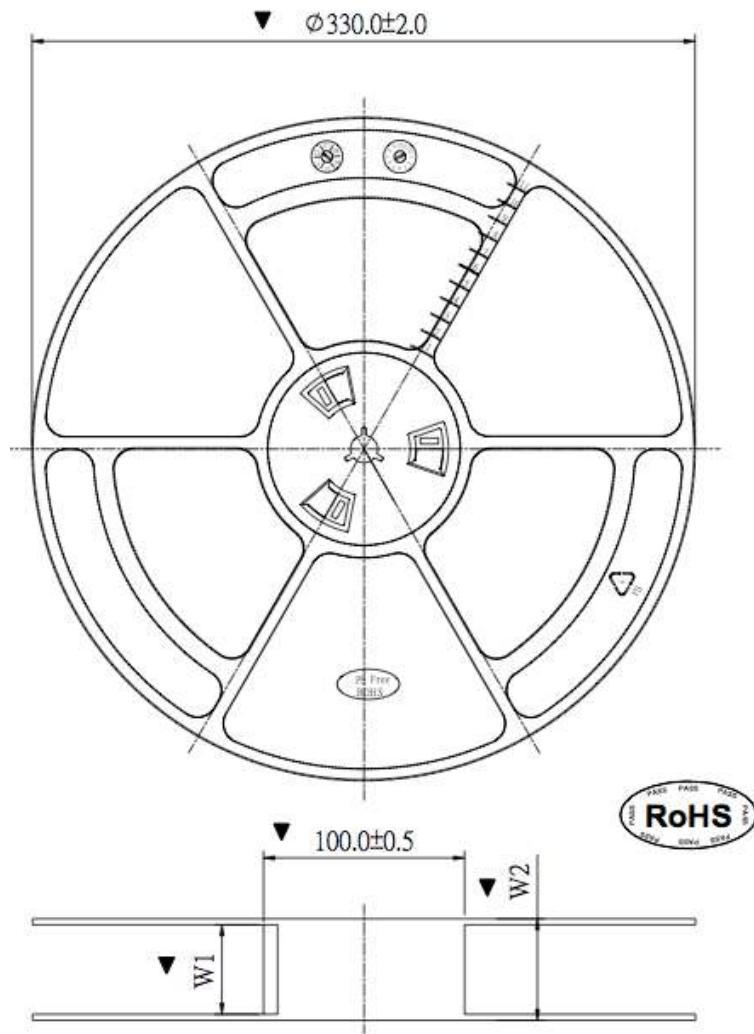

11. Recommended Footprint

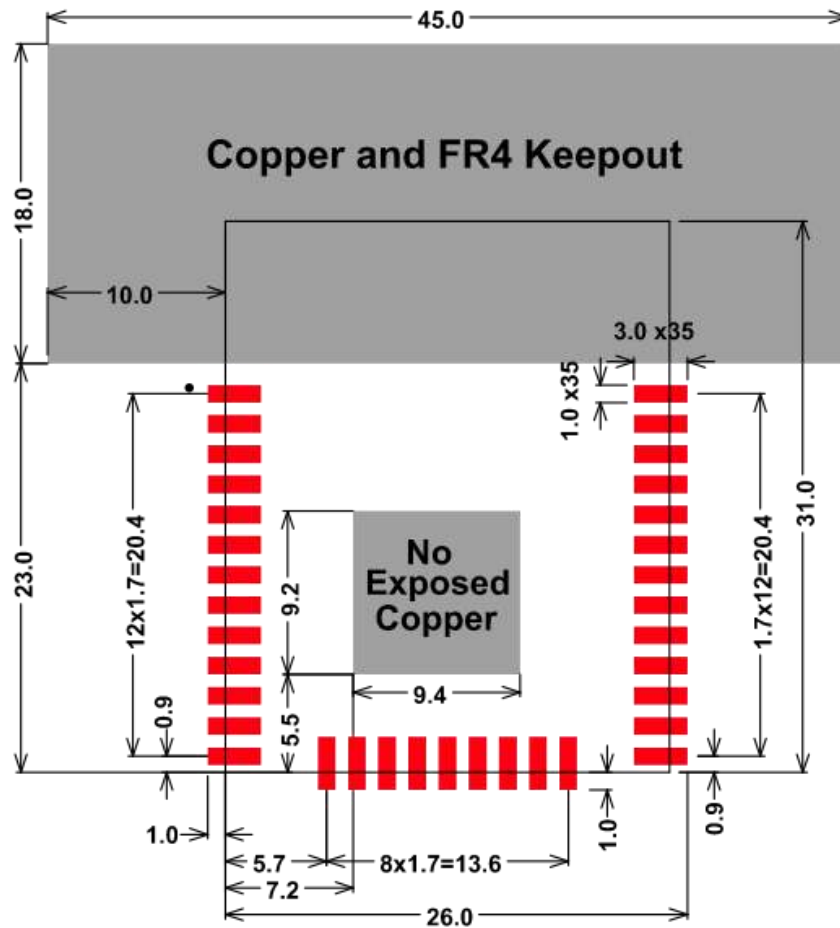

(all dimensions are in mm unless otherwise specified)

Notes:

1. Copper under solder mask is allowed in the “No Exposed Copper” region. Vias, even with full tenting, should not be placed in this region.
2. The “Copper and FR4 Keepout” guideline only applies to imp002-s which uses the built-in antenna.

12. Recommended Layout

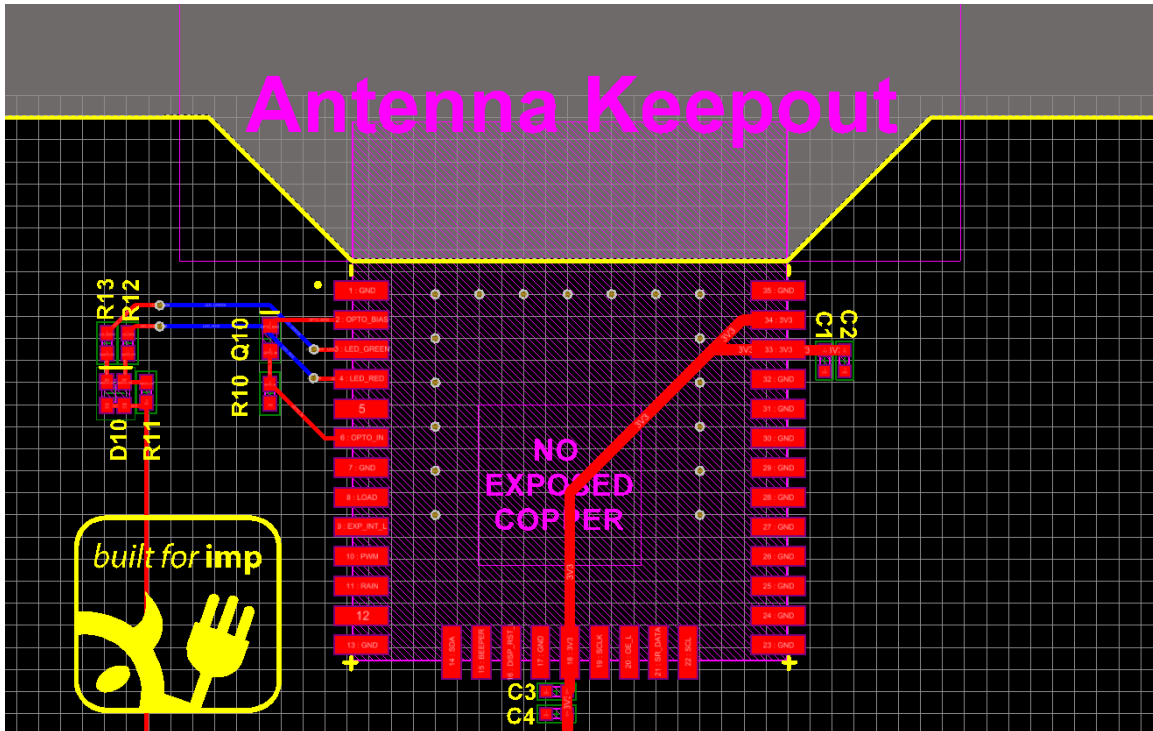

1: imp002 recommended layout with ground pours hidden

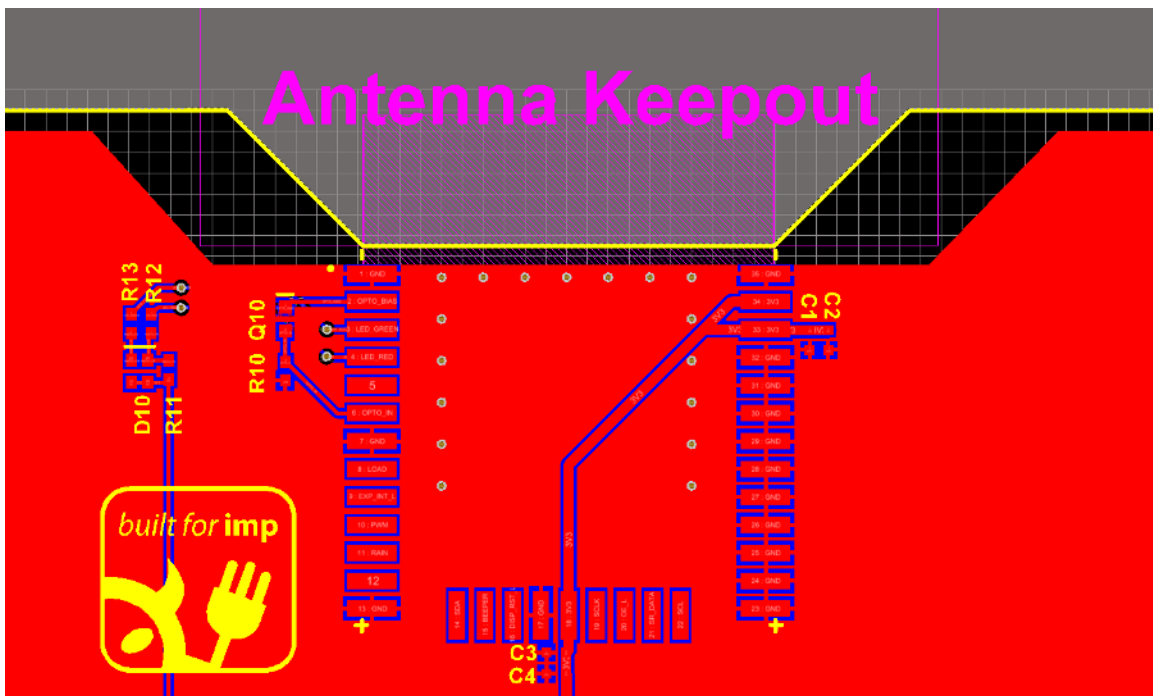

2: imp002 recommended layout with ground pours shown

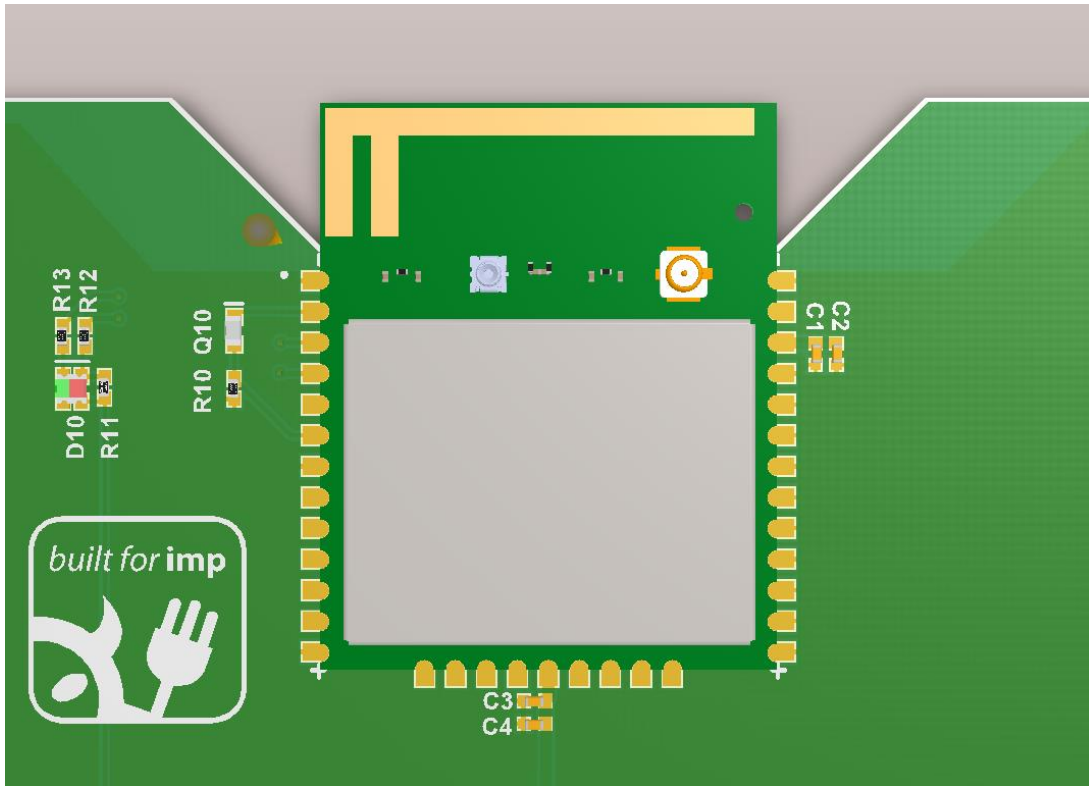

3: imp002 recommended layout shown in 3D

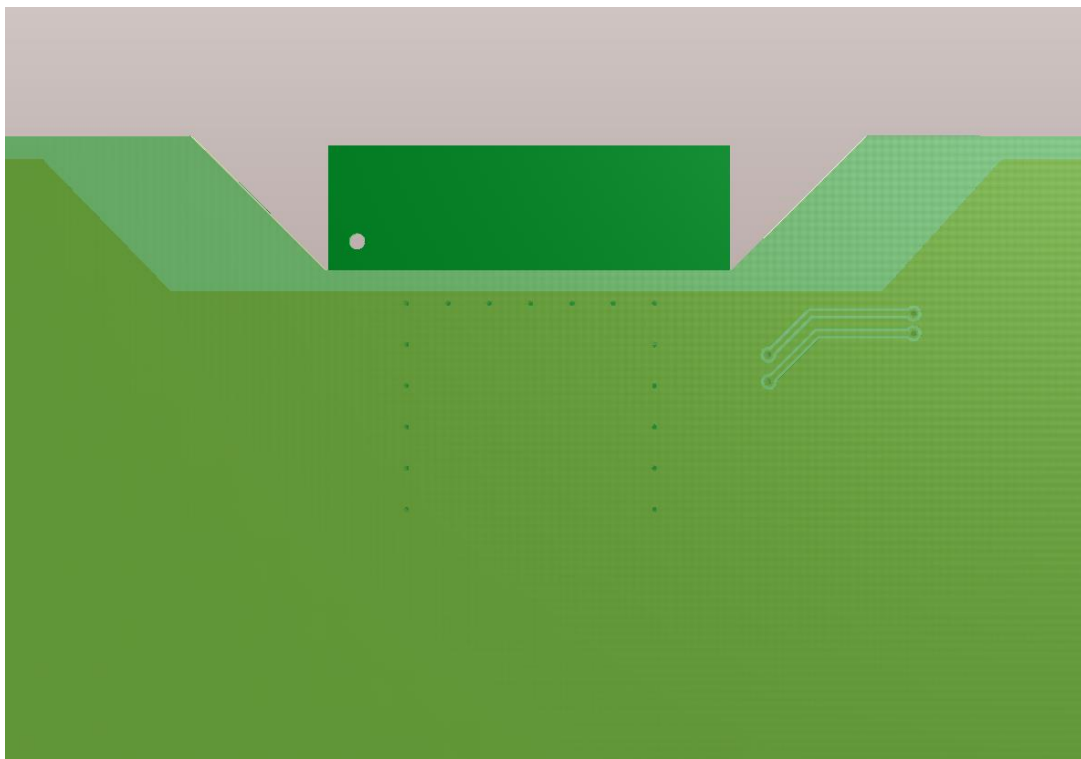

4: imp002 recommended layout shown in 3D, bottom of board

Electric Imp, inc.

Notes:

1. Do not place copper or board material in the antenna keepout area.
2. Ground planes must be poured on the top and bottom layer across the imp footprint, and stitched together with a row of vias between pin 1 and pin 35 on the imp002.
3. Bypass and filter capacitors should be placed as close as possible to the V_{DD} and V_{DDA} pins.

13. Recommended components

Bi-color LED	Manufacturer	Manufacturer's part number
Surface mount		
top-view	SunLED	XZMDKVG59W-1
	Liteon	LTST-C195KGJRKT
side-view	SunLED	XZMDKVG88W
	Bivar	SM1204BC
Through-hole		
3mm	SunLED	XLMDKVG34M
	Liteon	LTL1BEKVJNN

Phototransistor	Manufacturer	Manufacturer's part number
Surface mount		
top-view	Everlight	PT17-21C/L41/TR8
	Fairchild	KDT00030TR
side-view	SunLED	XZRNI56W-1
	Everlight	PT12-21C/TR8
Through-hole		
3mm	SunLED	XRNI30W-1
	Honeywell	SDP8405-003

Antenna	Manufacturer	Manufacturer's part number
for imp002-c-xx	Mag Layers	EDA-8709-2G4R2-A37

FCC Caution: To assure continued compliance, (example - use only shielded interface cables when connecting to computer or peripheral devices). Any changes or modifications not expressly approved by the party responsible for compliance could void the user's authority to operate this equipment.

This device complies with Part 15 of the FCC Rules. Operation is subject to the following two conditions: (1) This device may not cause harmful interference, and (2) this device must accept any interference received, including interference that may cause undesired operation.

14. Reflow Solder Profile

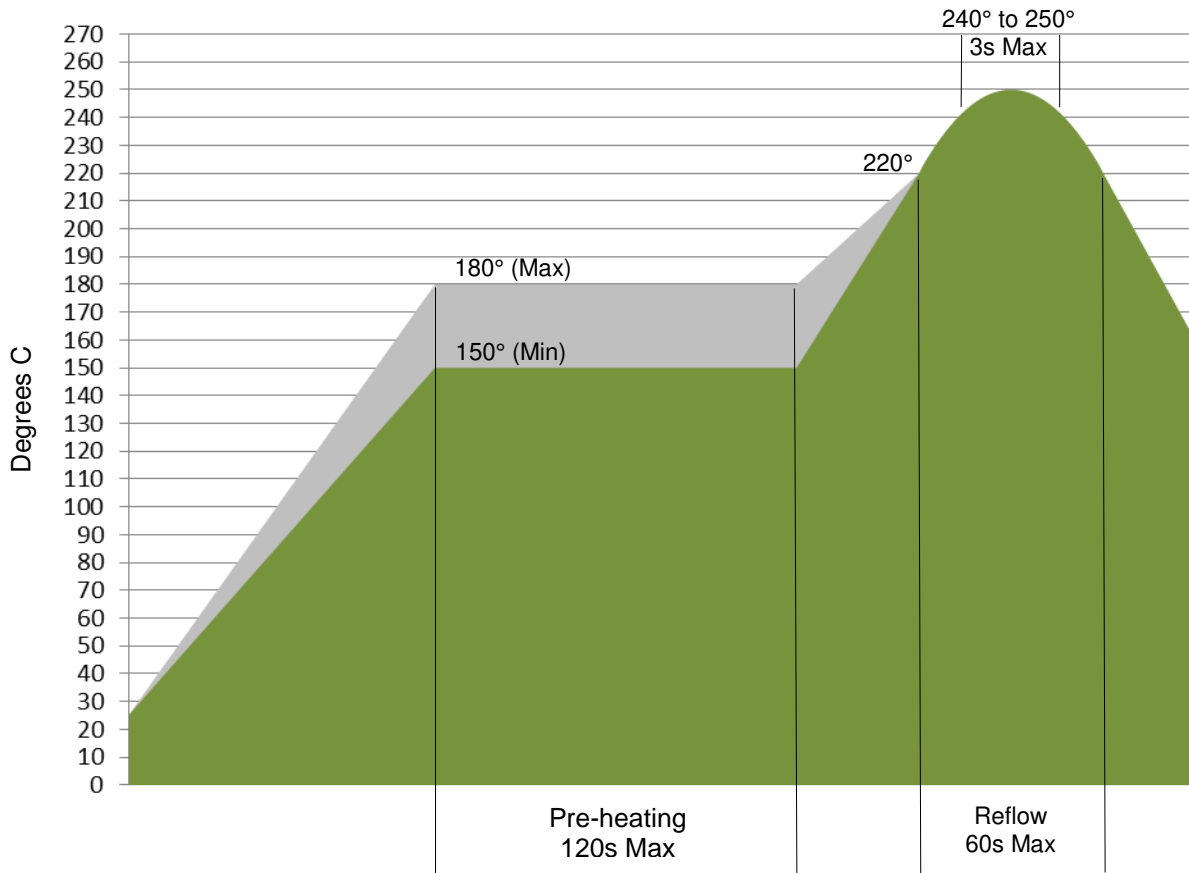

Version	Change description
20121217	updated mechanical drawings to reflect the smaller coax connector
20130103	updated recommended footprint to have a cleaner look
20130122	changed PIN 10 to 14 to PIN A to E
20130218	added FCC caution statement
20130219	added TX power in paragraph 1.2
20130221	updated TX power values
20130312	PWM was incorrectly listed as a pinmux option for PINA/PINB
20130313	Removed bogus U1-RX from PIND. added suggested opto components in paragraph 10
20130321	added application diagrams & t&r info
20130429	added MSL info & change V _{REF} to V _{DDA}
20130605	added common cathode diagram, updated overall module tolerances
20130611	updated electrical characteristics table
20130710	added IDDA typ value and reel disk drawing
20130819	added ordering information table, added paragraph 7 and amended paragraph 12
20140224	updated tape & reel info due to new packaging
20140225	Changed source format, updated branding.
20140226	Added application circuit and recommended layout
20140616	Fixed error in BlinkUp section: please use 10kΩ resistor across LED_RED.
20140722	Added Solder Profile
20141012	Removed Kingbright APT2012P3BT phototransistor rec, added Fairchild KDT00030TR
20150716	Clarified internal pulldown behavior on POWER_EN pin