

THIS DRAWING CONTAINS INFORMATION PROPRIETARY TO RF INDUSTRIES.
 ANY UNAUTHORIZED USE OF THIS DRAWING IS EXPRESSLY PROHIBITED
 WITHOUT WRITTEN PERMISSION FROM RF INDUSTRIES.
 ANY VIOLATION IS PUNISHABLE UNDER U.S. COPYRIGHT LAWS.

ALL DIMENSIONS ARE REFERENCE ONLY

PART NO.

RHV-100-D

REV	DESCRIPTION	DWN	DATE	APPROVED
-	ENGINEERING RELEASE	GGG	3/15/02	JDMc
A	CHANGED TO ASSEMBLY VIEW, UPDATE SPEC'S	JDM	12/24/03	JDMc
B	ADDED NOTE TO PIN	JDM	12/23/09	JDMc

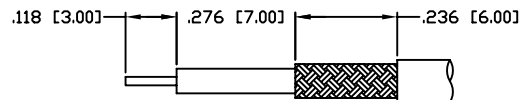
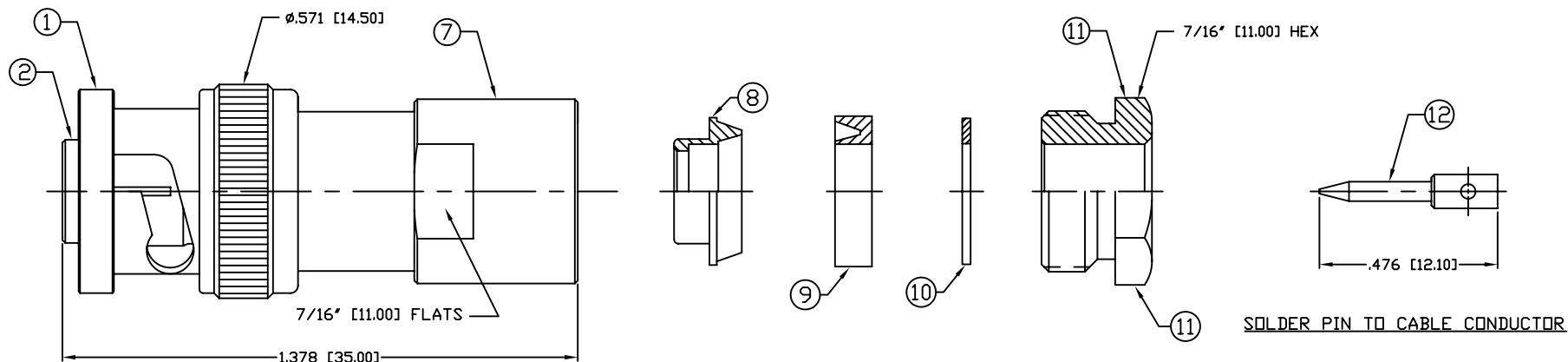

RECOMMENDED STRIPPING DIMENSIONS

SPECIFICATIONS:

IMPEDANCE: Non-Constant
 WORKING VOLTAGE: 1600 V rms @ sea level
 TEMPERATURE RANGE: -65°C TO 85°C
 INSULATION RESISTANCE: 5k M Ohms min.
 FOR RG-59, 59A, 59B, 62, 62A, 62C/U; ALPHA 9059, 9062,
 9830, 9840, 9845; BELDEN 8221, 8241, 9169, 9204,
 9228; CANARE LV-61S; CommScope 5555, 5560, 5563

1 SHELL	1	BRASS	NICKEL, 70μ"	000486	DRAWN JDM 12/23/09
2 INSULATOR	1	PTFE	----		
3 GASKET	1	BRASS	----		
4 WASHER	1	BRASS	NICKEL, 70μ"		
5 SPRING	1	SK-5	NICKEL, 70μ"		
6 WASHER	1	BRASS	NICKEL, 70μ"		
7 BODY	1	BRASS	NICKEL, 70μ"		
8 CLAMP	1	BRASS	NICKEL, 70μ"		
9 GASKET	1	SILICONE	----		
10 WASHER	1	BRASS	NICKEL, 70μ"		
11 BACK NUT	1	BRASS	NICKEL, 70μ"		
12 PIN	1	BRASS	GOLD, 3μ"		
13					
14					
# DESCRIPTION	QTY	MATRL	FINISH	APPROVALS	DATE

UNLESS OTHERWISE SPECIFIED:

1. REMOVE ALL BURRS
2. BREAK ALL CORNERS & EDGES .005 R. MAX.
3. CHAMFER 1ST & LAST THREADS 45°
4. SURFACE ROUGHNESS 63 FINISH MIL-STD-10
5. DIAMETERS ON COMMON CENTERS TO BE CONCENTRIC WITHIN .002 T.I.R.
6. ALL DIMENSIONS ARE AFTER PLATING.

DIMENSIONS ARE IN INCHES AND [MILLIMETERS]

UNLESS OTHERWISE NOTED TOLERANCES ARE:

DECIMALS	DIAMETER
.xxx±.003 [.08]	.xxx±.001 [.03]
.xx±.005 [.13]	.xx±.003 [.08]

RF connectors
 DIVISION OF RF INDUSTRIES, LTD.

7610 MIRAMAR RD
 SAN DIEGO, CA 92126
 (858) 549-6340
 (858) 549-6345 FAX

MHV PLUG CLAMP

SIZE	CABLE GROUP	DWG NO.	REV
A	D	RHV-100-D	B
SCALE: NTS		CAD FILE OUTLINE	SHEET 1 OF 1