

Description.
AMP SUPERSEAL 1,5 SERIES CONNECTORS

AMP SUPERSEAL 1,5 SERIES CONNECTORS

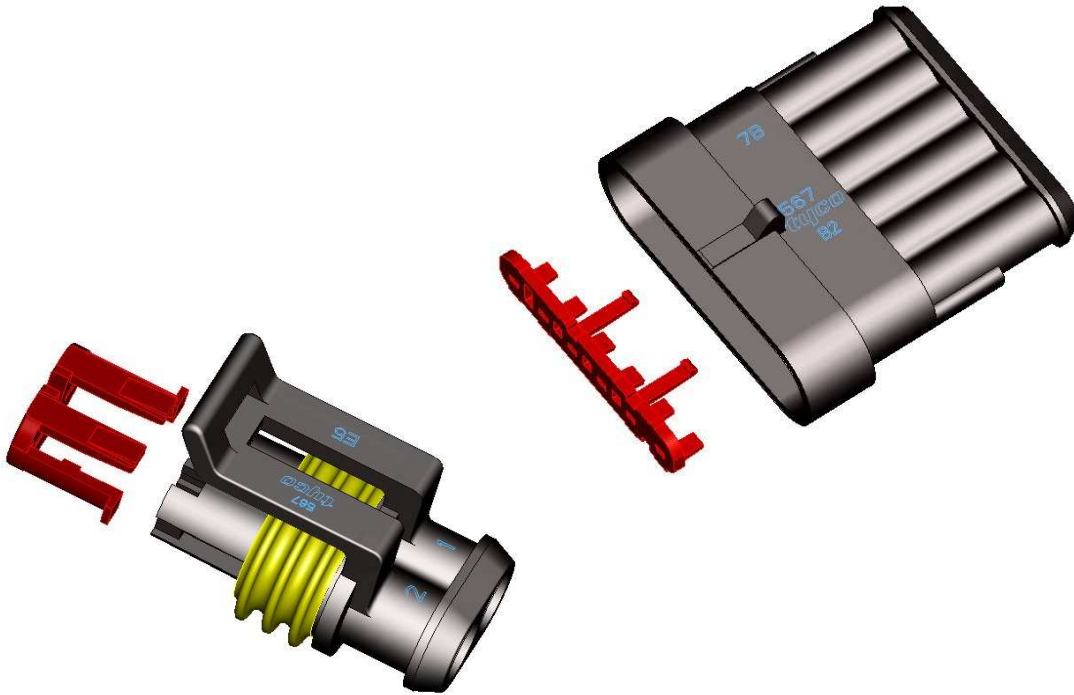

Product Code: 0933

GPL: 444

C2	ADDED NEW VERSIONS FOR APPLIANCE APPLICATIONS	M.G.	27/10/2008	M.G.	28/10/2008
rev letter	rev. record	DR	Date	CHK	Date
DR.		DATE	APVD		DATE
A.BRUNI		SEP. '91	A.BRUNI		SEP. '91

This specification is a controlled document.

This information is confidential and is disclosed to you on condition that no further disclosure is made by you to other than AMP personnel without written authorization from AMP Italia.

Page 1 of 18

* Trademark of AMP Incorporated

LOC I

1.0 SCOPE:

This specification covers the requirements for products performance, test methods and quality assurance provisions of following products:

NR. OF POSITIONS	FEMALE CONNECTORS (Housings assemblies for receptacle contacts, 1 to 6 positions, with sealing gasket and TPA device which warns if a contact is not correctly inserted in housing and doesn't allow the gasket to slip-off during the unmating operation)	MALE CONNECTORS Housings assemblies for tab contacts, 1 to 6 positions, with TPA device which warns when a contact is not correctly inserted in housing)
	1	282079-X
2	282080-X	282104-X
3	282087-X	282105-X
4	282088-X	282106-X
5	282089-X	282107-X
6	282090-X	282108-X

WIRE SIZE RANGE (mm²)	MINI-MIC RECEPTACLE CONTACTS	MINI-MIC TAB CONTACTS
0.35 – 0.5	282403-X	282404-X
0.75 – 1.5	282110-X	282109-X
1.5 – 2.5	282466-X	282465-X

Single wire seals for both tab and receptacle contacts : 281934-X

Rubber plug to seal unused cavities : 282081-1

REQUIREMENTS:

2.0 DESIGN AND CONSTRUCTION:

Product shall comply with the design, construction and physical dimensions specified in the applicable product drawing.

2.1 MATERIALS:

Components	Material	Finish, for contacts only
Contacts	Receptacle contacts: Phosphor Bronze Tab contacts: Brass	PreTin plated
Housings / Sec. Lock	PA 6.6, Glassfiber filled	/
Radial Sealing / Single wire seals	Liquid silicone rubber	/

2.2 RATINGS:

- A. Current Rating : 14A max. with 1,5 mm² wire
- B. Temperature Rating: -40°C to +125°C including the temperature increasing due to working current flow
- C. Maximum Operating Voltage: 24 Vd.c.. For application at higher voltage please contact Tyco Electronics.
- D. Protection Degree: IP 67, IPX6K, IP X9K according to IEC 529 and to DIN 40050, Part 9.

2.3 QUALITY ASSURANCE PROVISION:

A. Sample preparation:

The test samples to be used for the tests shall be prepared by randomly selecting from the current production, and the contact crimped in accordance with the Application Specification 114-20045. No sample shall be reused, unless otherwise specified.

B. Test Environment:

All the tests shall be performed under any combination of the following test conditions, unless otherwise specified.

Room temperature: 23 ± 2°C
Relative Humidity: 45÷70%
Atmospheric Pressure: 860÷1060 mbar

3.0 TEST REQUIREMENTS AND PROCEDURES SUMMARY:

FEATURES	TEST CONDITIONS	LIMITS
3.1 Voltage Drop	(mated connectors) Between two points on wires at 1cm from the housing edges. Test currents: 6A for 0,5sqmm wire 11A for 1,0sqmm wire 14A for 1,5sqmm wire	≤ 3 mV/A on new contacts. The voltage drop of wire must be subtracted
3.2 Contact resistance	(mated contacts) Between the ends of crimps. Test current: 10mA	≤ 3 mΩ on new contacts.
3.3 Insulation Resistance	(mated connectors) Between adjacent contacts apply 500 Vd.c. for 1 min.	≥ 200 MΩ (new contacts)
3.4 Dielectric withstanding voltage	Between adjacent contacts apply 1500Va.c. for 1 min.	No breakdown or flashes
3.5 Connector mating force	Mate connectors with their contacts loaded at a speed of 25÷100mm/min	1 pos. conn.: ≤ 80N 2÷6 pos. conn.: ≤ 120N
3.6 Connector unmating force	Unmate connectors with their contacts loaded at a speed of 25÷100mm/min: a) Without operate the locking lance b) Operating the locking lance	a) All positions: ≥ 145N b) 1 pos. conn.: ≤ 80N 2÷6 pos. conn.: ≤ 120N

FEATURES	TEST CONDITIONS	LIMITS
3.7 Single contact engaging force	Engage single rec.ctc. onto tab counterpart using a free floating fixture with a rate of 25-100mm/min of travel speed (tab as shown in Fig.1)	$\leq 8N$
3.8 Single contact disengaging force	Separate single rec.ctc. from tab counterpart using a free floating fixture with a rate of 25-100mm/min of travel speed (tab as shown in Fig.1)	$\geq 2,5N$
3.9 Retention force of the single contact in the housings	Apply an axial force to pull out contacts from relevant hsg. cavity using a free floating fixture with a tensile speed of 50-70mm/min. with and without anti-backout device	Without anti-backout device: $\geq 80N$ With anti-backout device: $\geq 90 N$
3.10 Crimping Tensile Strength	Pull out the contacts from the relevant wire using a free floating fixture at a tensile speed of 25 - 100 mm/min.	0.35sqmm wires: > 60N 0,5sqmm wires: > 70N 1,0sqmm wires: > 115N 1,5sqmm wires: > 155N
3.11: Corrosion Test 3.11a Salt spray corrosion	Subject mated contacts energized with voltage of 12Vd.c. to 150 hours of salt mist at 35°C (5% of NaCl) (single contacts mated in free air)	Voltage drop $\leq 5mV/A$
3.11b Kesternich corrosion	4 cycles composed of : - 8 hrs. of exposure to an atmosphere with 0.66% of SO ₂ at 40±2°C and 95% humidity - 16 hrs in free air. (single contacts mated in free air)	

FEATURES	TEST CONDITIONS	LIMITS
<p>3.12 Water resistance: Static immersion</p>	<p>Mated connectors subjected to 5 cycles composed of:</p> <ul style="list-style-type: none"> - 30 min. in oven at +125°C - 30 min. immersed in water with 5% of NaCl under a pressure of 0,01bar at a temperature of 23°C 	<ul style="list-style-type: none"> -Insulation resistance: $\geq 200M\Omega$ -No leakage detected to a visual examination
<p>3.13 Water resistance: Dynamic immersion</p>	<p>Mated connectors immersed in water with 5% on NaCl, under a pressure of 0,01bar at a temperature of 23°C.</p> <p>Wire pulled with a force of 1,5÷2,5N oscillated 100.000 times (as per Fig. 2).</p> <p>Oscillation frequency: 50cycles/min.</p>	<ul style="list-style-type: none"> -Insulation resistance: $\geq 200M\Omega$ -No leakage detected to a visual examination
<p>3.14 Water resistance: IP X6K Test</p>	<p>Test according to DIN 40050, Part 9.</p> <p>Duration: 3min. minimum</p> <p>Subject mated connectors completely loaded with terminals to water jet with following parameters:</p> <p>nozzle:6.3mm dia pressure: 1000kPa</p> <p>(test setup as per Fig. 4)</p>	<ul style="list-style-type: none"> -Insulation resistance as above specified. -No leakage detected to a visual examination
<p>3.15 Water resistance: IP X9K Test</p>	<p>Test according to DIN 40050, Part 9.</p> <p>Duration: 30s for each nozzle.</p> <p>Subject mated connectors completely loaded with terminals to the cumulative action of the four nozzles.</p> <p>(test setup as per Fig. 5)</p>	<ul style="list-style-type: none"> -Insulation resistance and dielectric withstanding voltage as above specified. -No leakage detected to a visual examination

FEATURES	TEST CONDITIONS	LIMITS
<p>3.16 Thermal cycling</p>	<p>Mated connectors subjected to:</p> <ul style="list-style-type: none"> - 14 cycles composed of: <ul style="list-style-type: none"> • 16 hours at +40°C, 95% r.h. • 2 hours at -40°C • 2 hours at +125°C • 4 hours at +23°C (max.time to change condition: 3min.) - exposure for 24 hours at +40°C and 95% r.h. - 10 mating and unmating operations 	<ul style="list-style-type: none"> - No damages - Insulation resistance and dielectric withstanding resistance as above specified. - Voltage drop $\leq 5\text{mV/A}$ - Contact retention in housing, mating/unmating forces as above specified
<p>3.17 Ageing resistance</p>	<p>Mated connectors subjected to:</p> <ul style="list-style-type: none"> - 100 hours at +125°C - 10 mating/unmating operations 	<ul style="list-style-type: none"> - No damages - Insulation resistance and dielectric withstanding resistance as above specified - Voltage drop $\leq 5\text{mV/A}$ - Contact retention in housing, mating/unmating forces as above specified
<p>3.18 Chemical resistance</p>	<p>Mated connectors immersed for 3 min. in:</p> <ul style="list-style-type: none"> - Brake fluid at +50°C - Anti-freeze fluid at +23°C - Transmission and engine oil at +100°C - Gasoline at +23°C - Diesel fuel at +23°C - Window cleaner at +23°C 	<ul style="list-style-type: none"> - No damages - No leakages detected at visual examination - Contact retention in housing, mating/unmating forces as above specified
<p>3.19 Ozone gas resistance</p>	<p>Mated connectors exposed for 70 hours at an atmosphere with 0,5ppM of ozone at 50°C</p>	<ul style="list-style-type: none"> - No damages - Contact retention in housing, mating/unmating forces as above specified

FEATURES	TEST CONDITIONS	LIMITS
<p>3.20 Vibration Test</p>	<p>Mated connectors placed on a platform as per Fig.3, subjected to vibrations with following parameters:</p> <ul style="list-style-type: none"> - Frequency: 10 - 500 - 10Hz - Speed of frequency variation: 1octave/min. - Displacement: 0,75mm for frequencies below 70Hz. Over 70Hz maintain a constant acceleration of 150m/s² - Duration: 2hours each axis - 10 cycles mating/unmating 	<ul style="list-style-type: none"> - No damages - Dielectric withstanding resistance as above specified - Voltage drop $\leq 5\text{mV/A}$ - Contact retention in housing, mating/unmating forces as above specified - No circuit break greater than 1μs
<p>3.21 High temperature resistance with current load</p>	<p>Mated connectors subjected to a temperature of 80°C for 5 hours with all contacts loaded with max.current of 14A (1,5sqmm wires)</p>	<p>Max. increase of temperature detected on transition between contact body and wire barrel: 50°C</p>
<p>3.22 Current overload</p>	<p>Mated connectors subjected to 500 cycles with current of 21A (1,5sqmm wires).</p> <p>Each cycle composed of:</p> <ul style="list-style-type: none"> - 45 min. current ON - 15 min. current OFF 	<p>Max. increase of temperature detected on transition between contact body and wire barrel: 60°C</p>
<p>3.23 Durability</p>	<p>Mate-unmate 10 times the tabs of Fig.1 at a constant speed of 25÷100mm/min.</p>	<p>Voltage drop: $\leq 3\text{mV/A}$</p> <p>Contact resistance: $\leq 3\text{m}\Omega$</p>

NOTE: SEE NEXT PAGE FOR TEST GROUPS AND SEQUENCE.

NUM.	TEST DESCRIPTION	GROUPS AND SEQUENCE															
		A	B	C	D	E	F	G	H	I	L	M	N	O	P	Q	R
3.0	VISUAL EXAMINATION	1, 11	1	1	1, 5	1, 5	1, 17	1, 5	1, 5	1, 12	1, 5	1, 16	1, 9	1, 10	1, 5	1, 5	1, 7
3.1	VOLTAGE DROP	4, 9			2, 4	2, 4	4, 13	2, 4	2, 4	5, 8		5, 12					
3.2	CONTACT RESISTANCE	5, 1															
3.3	INSULATION RESISTANCE						6, 11				2, 4	6, 10			2, 4	2, 4	2, 5
3.4	DIELECTRIC WITHSTANDING VOLTAGE						7, 12					7, 11					3, 6
3.5	CONNECTOR MATING FORCE						2, 15			2, 10		2, 14	2, 7	2, 8			
3.6	CONNECTOR UNMATING FORCE						3, 14			3, 9		3, 13	3, 6	3, 7			
3.7	CTC. ENGAGING FORCE	2, 7															
3.8	CTC. DISENGAGING FORCE	3, 8															
3.9	CONTACT RETENTION IN HSG.		2				5, 16			4, 11		4, 15	4, 8	4, 9			
3.10	CRIMP TENSILE STRENGTH			2													
3.11a	SALT SPRAY CORROSION								3								
3.11b	KESTERNICH CORROSION							3									
3.12	STATIC IMMERSION										3						
3.13	DYNAMIC IMMERSION						10 (**)						6 (**)	3			
3.14	IP X6K TEST															3	
3.15	IP X9K TEST																4
3.16	THERMAL CYCLING						8										
3.17	AGEING RESISTANCE											8					
3.18	CHEMICAL RESISTANCE												5				
3.19	OZONE GAS RESISTANCE													5			
3.20	VIBRATION TEST									6							
3.21	HIGH TEMP. RESISTANCE W. CURRENT LOAD				3												
3.22	CURRENT OVERLOAD					3											
3.23	DURABILITY	6					9			7		9					

(**): 10.000 CYCLES ONLY

TEST TAB DIMENSIONS

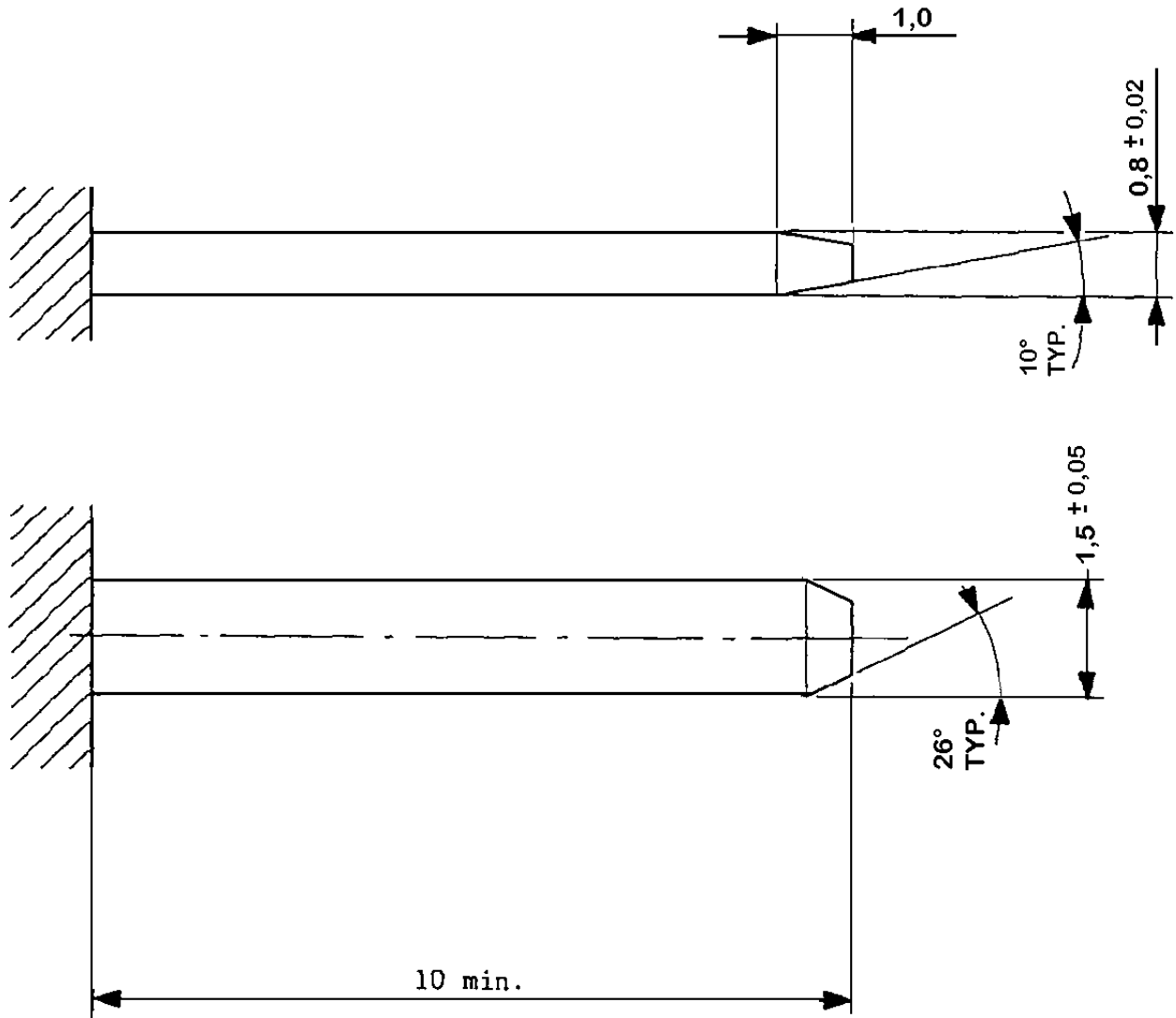

FIG. 1

DYNAMIC IMMERSION TEST SETUP

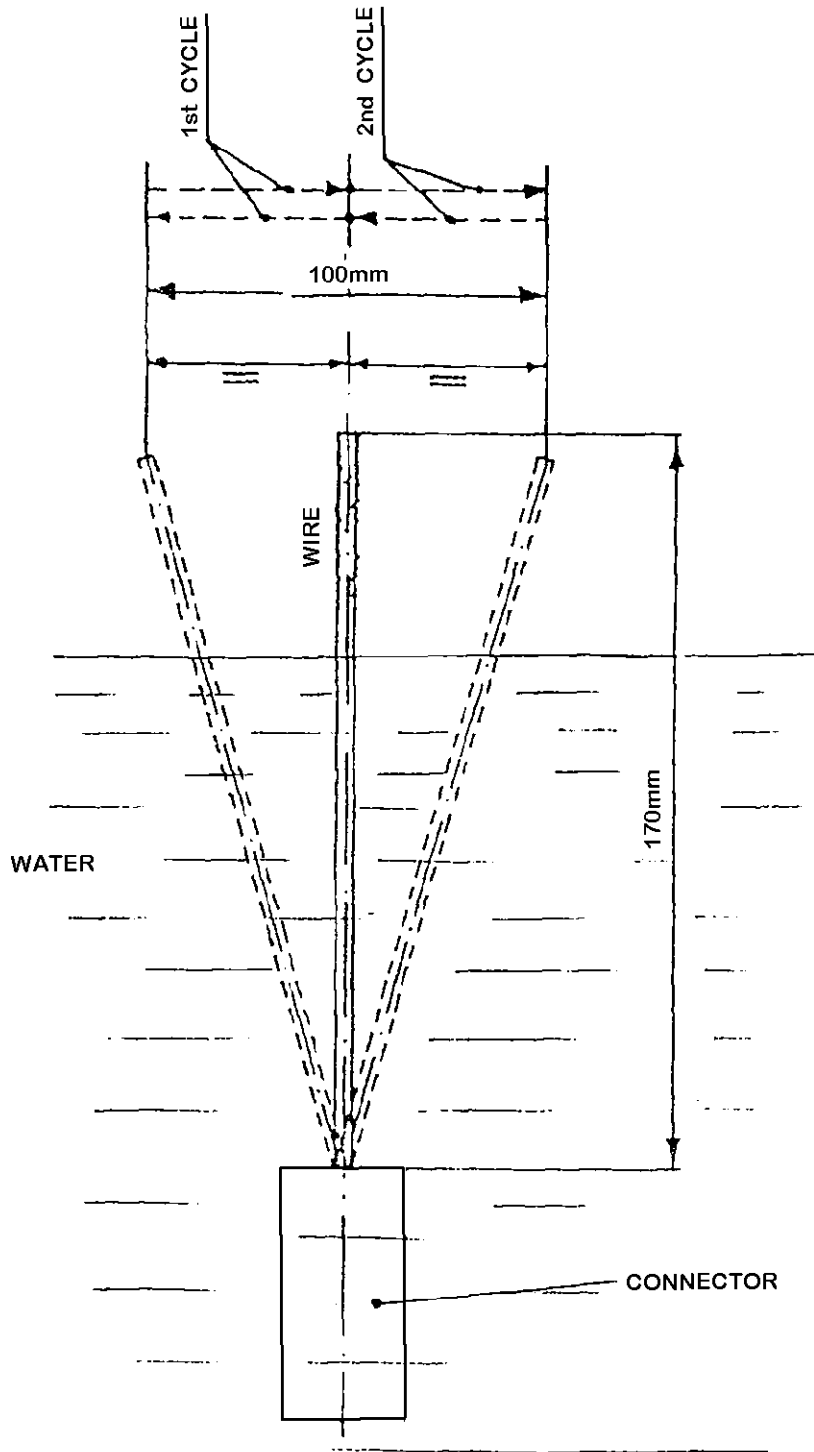

FIG. 2

VIBRATION TEST SETUP

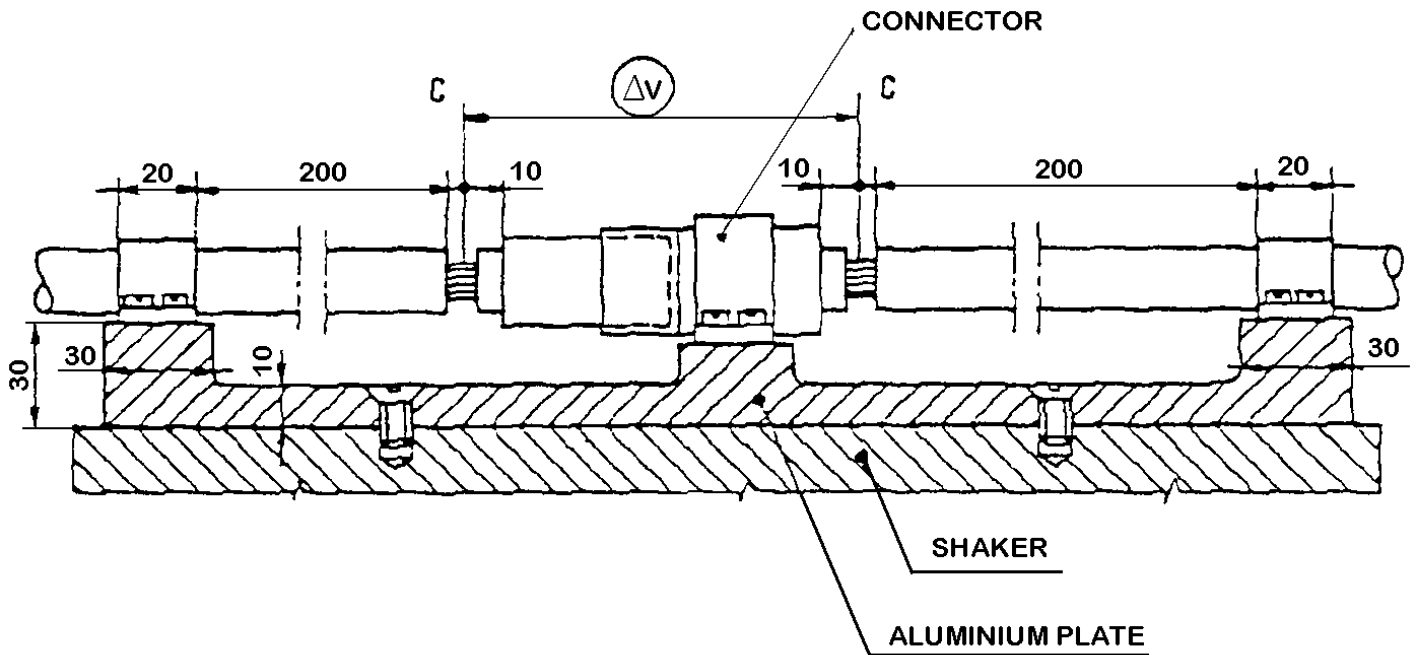

FIG. 3

IP X6K TEST SETUP

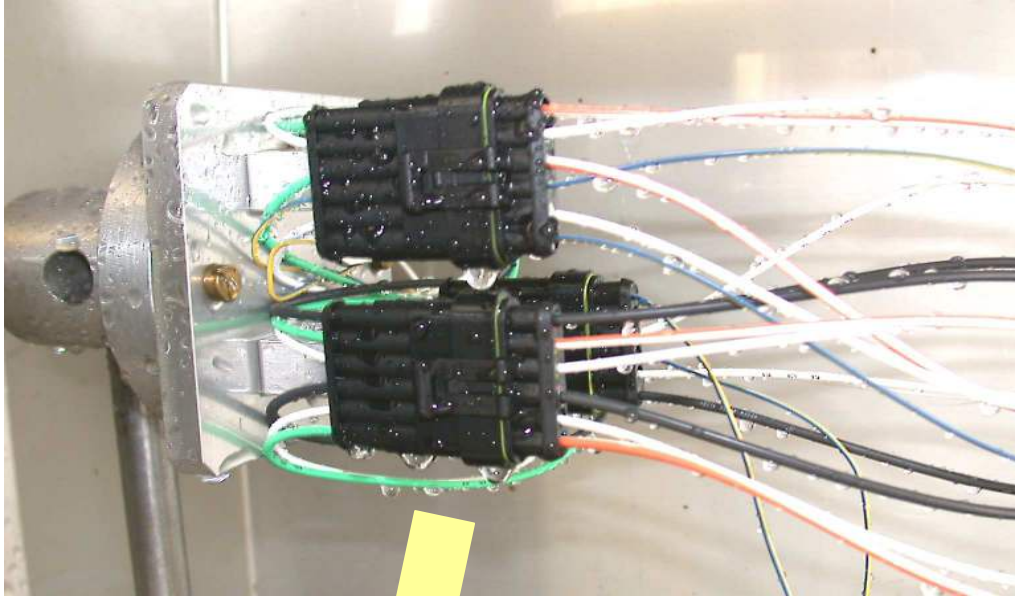

FIG. 4

IP X9K TEST SETUP

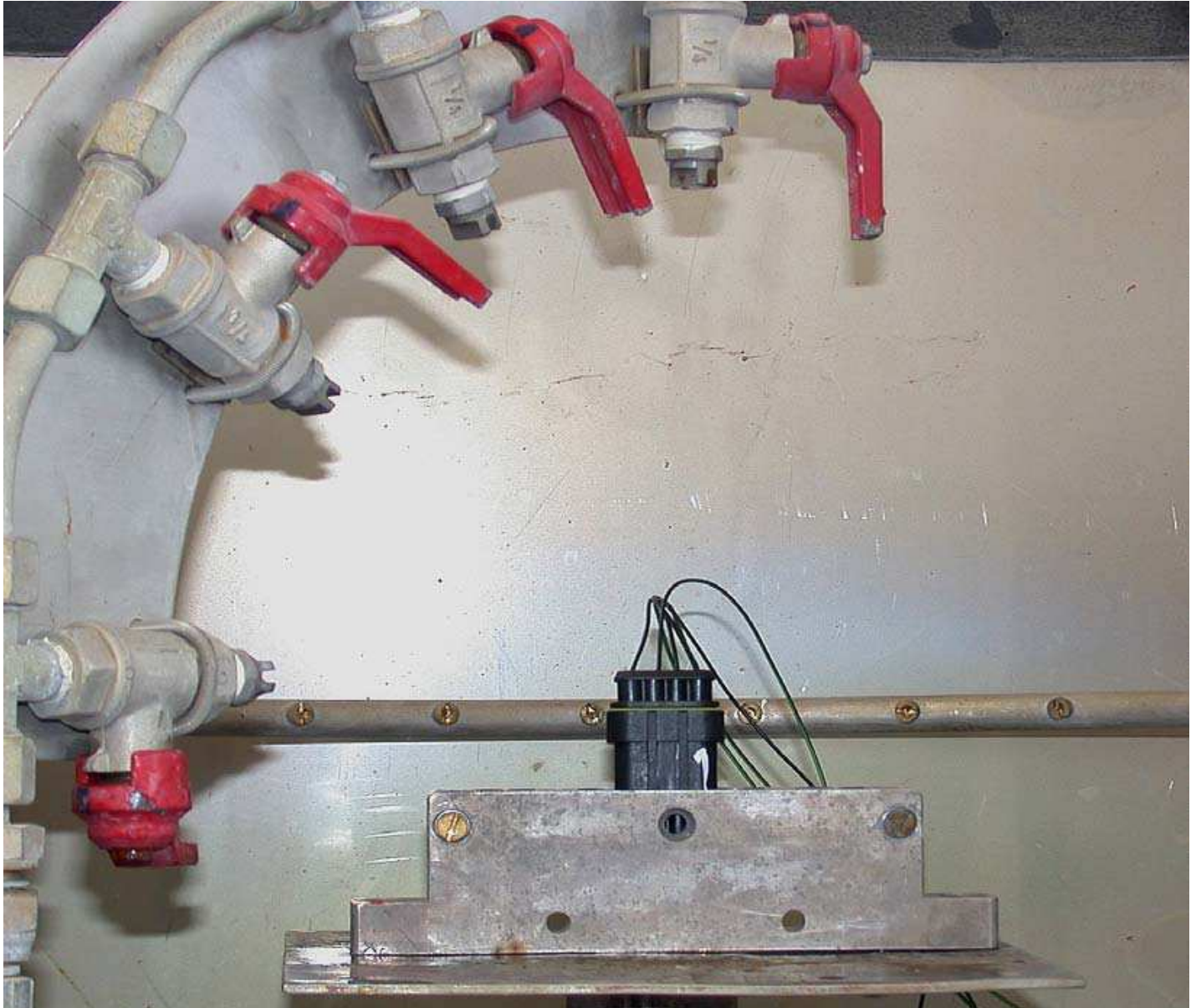

FIG. 5

ADDENDUM 1 HOUSEHOLD APPLIANCE APPLICATIONS

1.0 SCOPE:

The following pages of the Specification cover further requirements (apart those already listed in the previous pages) for product performance, test methods and quality assurance provisions of following products:

NR. OF POSITIONS	FEMALE CONNECTORS (Housings assemblies for receptacle contacts, 2, 3, 6 positions, with sealing gasket and TPA device)	MALE CONNECTORS (Housings assemblies for tab contacts, 2, 3, 6 positions, with TPA device)
2	1745096-1	1745099-1
3	1745083-1	1745082-1
6	1745085-1	1745084-1

WIRE SIZE RANGE (mm ²)	MINI-MIC RECEPTACLE CONTACTS	MINI-MIC TAB CONTACTS
0.35 – 0.5	282403-X	282404-X
0.75 – 1.5	282110-X	282109-X
1.5 – 2.5	282466-X	282465-X

Single wire seals for both tab and receptacle contacts : 281934-X

Rubber plug : 282081-1. It must be always inserted in case of unused cavities in the final application.

2.0 DESIGN AND CONSTRUCTION:

Product shall comply with the design, construction and physical dimensions specified in the applicable product drawing.

2.1 MATERIALS:

Components	Material	Note / finish
Contacts	Receptacle contacts: Phosphor Bronze Tab contacts: Brass	PreTin plated
Housings / Sec. Lock	PA 6.6, Glassfiber filled – V2	Acc. to IEC 60335-1 CTI > 250V
Radial Sealing / Single wire seals	Liquid silicone rubber	/

2.2 APPLICABLE DOCUMENTS:

TE Documents:

- | | |
|-----------------------------|---|
| A. 109-1 | Tyco General requirements for Test Specifications |
| B. Customer drawings | P/Ns see Table at para. 1.0 |
| C. 114-20045 | Terminals Application Specification, for wires with basic insulation. |

Other Documents:

- | | |
|--------------------------|--|
| A. DIN 72551 | Electrical cables, thermoplastic insulated dimensions |
| B. IEC 60112 | Method for determining the proof and the comparative tracking indices |
| C. IEC 60695-2-11 | Fire hazard testing - Part 2-11. Glowing/hot wire-based test methods - Glow-wire flammability test method for end products |
| D. IEC 60998-... | Connecting devices for low-voltage circuits for household and similar purposes.. |
| E. IEC 60335-1 | Household and similar electrical appliances – Safety |
| F. IEC 61984 | Connectors – Safety requirements and tests |

2.3 RATINGS:

- A. Current Rating : 14A max. with 1,5 mm² wire
- B. Temperature Rating: -40°C to +125°C including the temperature increasing due to working current flow
- C. Maximum Operating Voltage: 250Vac (Overvoltage class: II; Pollution degree: 2)
- D. Protection Degree: IP 67, IPX6K, IP X9K according to IEC 529 and to DIN 40050, Part 9.
- E. Durability: 10 mating cycles

2.4 OTHER :

No plug/unplug admissible under load

3.0 TESTS PERFORMED AND PROCEDURES SUMMARY :

FEATURES	TEST CONDITIONS	LIMITS
3.1 BALL PRESSURE TEST	Acc. to IEC 60998-1 Test temperature: 125±2°C Duration: 1h	Impression diameter shall not exceed 2mm.
3.2 GLOW WIRE TEST	Acc. to IEC 60695-2-11 Test temperature1: 750°C Test temperature2: 850°C	Acc. to IEC 60335-1
3.3 TRACKING INDEX PROOF	Acc. to IEC 60112	PTI 250V FULFILLED

BALL PRESSURE TEST SETUP



GLOW WIRE TEST SETUP

Points of glow tip application:

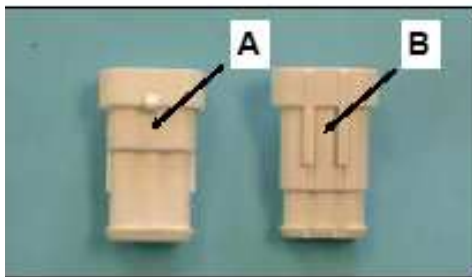

After glow tip application:

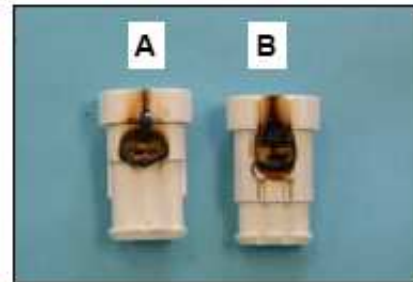

Points of glow tip application:

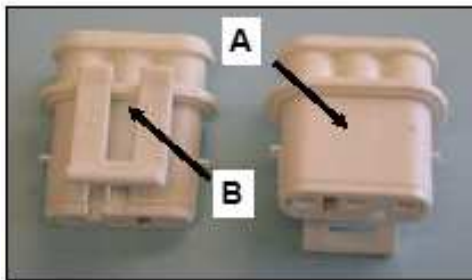

After glow tip application:

