

PNP SILICON LOW POWER TRANSISTOR

Qualified per MIL-PRF-19500/323

DEVICES

2N3250A **2N3251A**
2N3250AUB **2N3251AUB**

LEVELS

JAN
JANTX
JANTXV

ABSOLUTE MAXIMUM RATINGS ($T_C = +25^\circ\text{C}$ unless otherwise noted)

Parameters / Test Conditions	Symbol	Value	Unit
Collector-Emitter Voltage	V_{CEO}	60	Vdc
Collector-Base Voltage	V_{CBO}	60	Vdc
Emitter-Base Voltage	V_{EBO}	5.0	Vdc
Collector Current	I_C	200	mAdc
Total Power Dissipation	P_T	0.36 1.2	W
		@ $T_A = +25^\circ\text{C}$ ⁽¹⁾ @ $T_C = +25^\circ\text{C}$ ⁽¹⁾	
Operating & Storage Junction Temperature Range	T_J, T_{stg}	-65 to +200	$^\circ\text{C}$

THERMAL CHARACTERISTICS

Parameters / Test Conditions	Symbol	Max.	Unit
Thermal Resistance, Junction-to-Case	$R_{\theta JC}$ ⁽¹⁾	150	$^\circ\text{C}/\text{W}$

Note:

1/ Consult 19500/323 for thermal curves

ELECTRICAL CHARACTERISTICS ($T_A = +25^\circ\text{C}$, unless otherwise noted)

Parameters / Test Conditions	Symbol	Min.	Max.	Unit
OFF CHARACTERISTICS				
Collector-Emitter Breakdown Voltage $I_C = 10\text{mAdc}$	$V_{(BR)CEO}$	60		Vdc
Collector-Emitter Cutoff Voltage $V_{BE} = 3.0\text{Vdc}, V_{CE} = 40\text{Vdc}$ $V_{BE} = 3.0\text{Vdc}, V_{CE} = 40\text{Vdc}$ $T_A = 150^\circ\text{C}$	I_{CEX}		20 20	ηAdc μAdc
Collector-Base Cutoff Current $V_{CB} = 60\text{Vdc}$ $V_{CB} = 40\text{Vdc}$	I_{CBO}		10 20	μAdc ηAdc
Emitter-Base Cutoff Current $V_{EB} = 5.0\text{Vdc}$	I_{EBO}		10	μAdc
Collector-Emitter Cutoff Voltage $V_{BE} = 3.0\text{Vdc}, V_{CE} = 40\text{Vdc}$	I_{BEX}		50	ηAdc

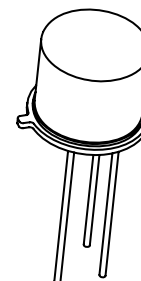

TO-39 (TO-205AD)

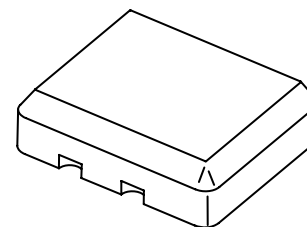

UB Package

ELECTRICAL CHARACTERISTICS ($T_A = +25^\circ\text{C}$, unless otherwise noted) (CONT.)

Parameters / Test Conditions	Symbol	Min.	Max.	Unit
ON CHARACTERISTICS ⁽²⁾				
Forward-Current Transfer Ratio $I_C = 0.1\text{mA}$, $V_{CE} = 1.0\text{Vdc}$	2N3250A, AUB 2N3251A, AUB	40 80		
$I_C = 1.0\text{mA}$, $V_{CE} = 1.0\text{Vdc}$	2N3250A, AUB 2N3251A, AUB	45 90		
$I_C = 10\text{mA}$, $V_{CE} = 1.0\text{Vdc}$	2N3250A, AUB 2N3251A, AUB	50 100	150 300	
$I_C = 50\text{mA}$, $V_{CE} = 1.0\text{Vdc}$	2N3250A, AUB 2N3251A, AUB	15 30		
$I_C = 1.0\text{mA}$, $V_{CE} = 1.0\text{Vdc}$ $T_A = -55^\circ\text{C}$	2N3250A, AUB 2N3251A, AUB	20 40		
Collector-Emitter Saturation Voltage $I_C = 10\text{mA}$, $I_B = 1.0\text{mA}$ $I_C = 50\text{mA}$, $I_B = 5.0\text{mA}$	$V_{CE(sat)}$		0.25 0.50	Vdc
Base-Emitter Saturation Voltage $I_C = 10\text{mA}$, $I_B = 1.0\text{mA}$ $I_C = 50\text{mA}$, $I_B = 5.0\text{mA}$	$V_{BE(sat)}$	0.60	0.90 1.20	Vdc

DYNAMIC CHARACTERISTICS

Parameters / Test Conditions	Symbol	Min.	Max.	Unit
Small-Signal Short-Circuit Forward Current Transfer Ratio $I_C = 1.0\text{mA}$, $V_{CE} = 10\text{Vdc}$, $f = 1.0\text{kHz}$	2N3250A, AUB 2N3251A, AUB	50 100	200 400	
Magnitude of Common Emitter Small-Signal Short-Circuit Forward Current Transfer Ratio $I_C = 10\text{mA}$, $V_{CE} = 20\text{Vdc}$, $f = 100\text{kHz}$	2N3250A, AUB 2N3251A, AUB	2.5 3.0	9.0 9.0	
Output Capacitance $V_{CB} = 10\text{Vdc}$, $I_E = 0$, $100\text{kHz} \leq f \leq 1.0\text{MHz}$	C_{obo}		6.0	pF
Input Capacitance $V_{EB} = 1.0\text{Vdc}$, $I_C = 0$, $100\text{kHz} \leq f \leq 1.0\text{MHz}$	C_{ibo}		8.0	pF

SWITCHING CHARACTERISTICS

Parameters / Test Conditions	Symbol	Min.	Max.	Unit
Turn-On Time $V_{CC} = 3.0\text{Vdc}$; $I_C = 10\text{mA}$; $I_{B1} = 1.0\text{mA}$	t_{on}		70	ns
Turn-Off Time $V_{CC} = 3.0\text{Vdc}$; $I_C = 10\text{mA}$; $I_{B1} = I_{B2} = 1.0\text{mA}$	2N3250A, AUB 2N3251A, AUB		250 300	ns

(2) Pulse Test: Pulse Width = 300 μs , Duty Cycle $\leq 2.0\%$

PACKAGE DIMENSIONS

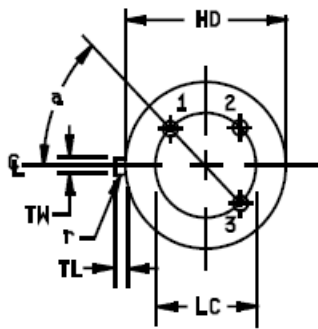
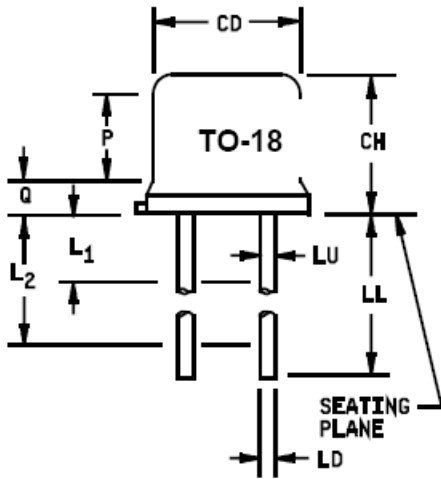

Symbol	Dimensions				Notes
	Inches		Millimeters		
	Min	Max	Min	Max	
CD	.178	.195	4.52	4.95	
CH	.170	.210	4.32	5.33	
HD	.209	.230	5.31	5.74	
LC	.100TP		2.54 TP		6
LD	.016	.021	0.41	0.53	7, 8
LL	.500	.750	12.70	19.05	7, 8
LU	.016	.019	0.41	0.48	7, 8
L1		.050		1.27	7, 8
L2	.250		6.35		7, 8
P	.100		2.54		
Q		.040		1.02	5
TL	.028	.048	0.71	1.22	3, 4
TW	.036	.046	0.91	1.17	3
r		.010		0.25	10
α	45° TP		45° TP		6

NOTES:

1. Dimension are in inches.
2. Millimeters are given for general information only.
3. Beyond r (radius) maximum, TH shall be held for a minimum length of .011 inch (0.28 mm).
4. Dimension TL measured from maximum HD.
5. Body contour optional within zone defined by HD, CD, and Q.
6. Leads at gauge plane .054 +.001 -.000 inch (1.37 +0.03 -0.00 mm) below seating plane shall be within .007 inch (0.18 mm) radius of true position (TP) at maximum material condition (MMC) relative to tab at MMC. The device may be measured by direct methods or by the gauge and gauging procedure shown in figure 2.
7. Dimension LU applies between L1 and L2. Dimension LD applies between L2 and LL minimum. Diameter is uncontrolled in L1 and beyond LL minimum.
8. All three leads.
9. The collector shall be internally connected to the case.
10. Dimension r (radius) applies to both inside corners of tab.
11. In accordance with ASME Y14.5M, diameters are equivalent to φx symbology.
12. Lead 1 = emitter, lead 2 = base, lead 3 = collector.

FIGURE 1. Physical dimensions (similar to TO-18).

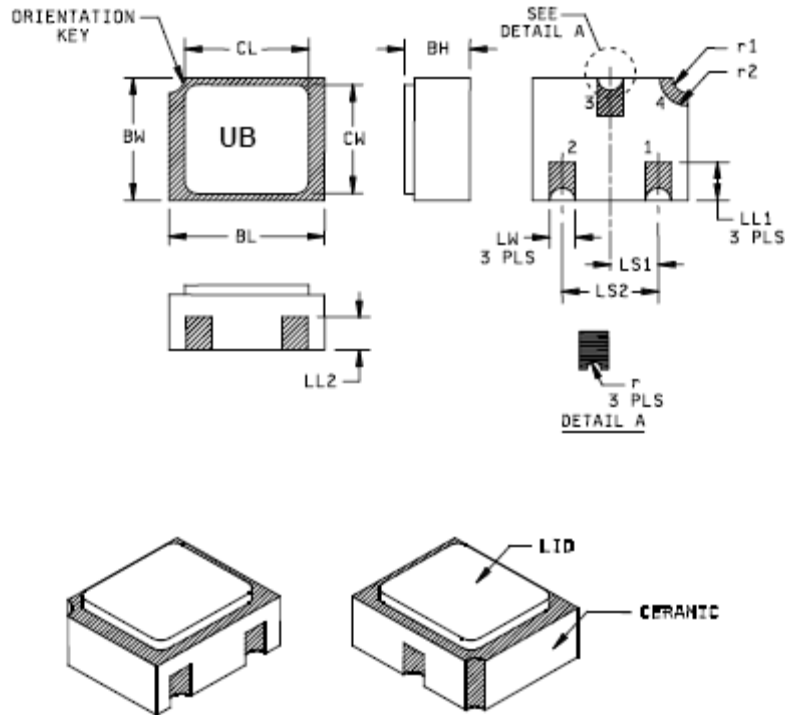

Ltr.	Dimensions				Note	Ltr.	Dimensions				Note
	Inches		Millimeters				Inches		Millimeters		
	Min	Max	Min	Max			Min	Max	Min	Max	
BH	.046	.056	1.17	1.42		LS ₁	.035	.039	0.89	0.99	
BL	.115	.128	2.92	3.25		LS ₂	0.71	.079	1.80	2.01	
BW	.085	.108	2.16	2.74		LW	.016	.024	0.41	0.61	
CL		.128		3.25		r		.008		0.20	
CW		.108		2.74		r ₁		.012		0.31	
LL ₁	.022	.038	0.56	0.96		r ₂		.022		0.56	
LL ₂	.017	.035	0.43	0.89							

NOTES:

1. Dimensions are in inches.
2. Millimeters are given for general information only.
3. Hatched areas on package denote metallized areas
4. Pad 1 = Base, Pad 2 = Emitter, Pad 3 = Collector, Pad 4 = Shielding connected to the lid.
5. In accordance with ASME Y14.5M, diameters are equivalent to ϕ x symbology.

FIGURE 2. Physical dimensions, surface mount (UB version).