

#18-24 TERMINAL SHOWN

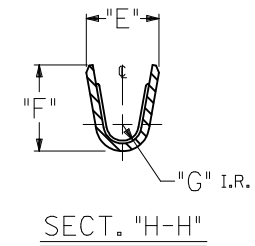

NOTES:

1. MATERIAL: PHOS. BRONZE
2. FINISH:
 - 2 = SELECTIVE GOLD PLATE .000030/(0.00076) MIN., AND SELECTIVE MATTE TIN .000100/(0.00254) OVER .000050/(0.00127) MIN. NICKEL OVERALL.
 - 3 = SELECTIVE GOLD PLATE .000015/(0.00038) MIN., AND SELECTIVE MATTE TIN .000080/(0.00203) OVER .000050/(0.00127) MIN. NICKEL OVERALL.
 - 4 = SELECTIVE GOLD PLATE .000050/(0.00127) MIN., AND SELECTIVE MATTE TIN .000100/(0.00254) OVER .000050/(0.00127) MIN. NICKEL OVERALL.
3. PRODUCT SPECIFICATION: SEE PSX-44485-0001.
4. PACKAGING SPECIFICATION: PK-44485-001 FOR CHAIN TERMINALS
PK-5556-003 FOR LOOSE TERMINALS
5. MATES WITH 5558, 5566 AND 5569 SERIES CONNECTORS.
6. TERMINAL FOR USE WITH 5557, 30067, 42474, 44516, SERIES HOUSINGS.
- △ THE NUMBER OF SERRATIONS TO BE ONE FOR WIRE RANGE #22-28
8. WHEN TERMINALS ARE INSTALLED IN THE HOUSING THE WIRES ARE TO BE DRESSED IN SUCH A MANNER TO ALLOW THE TERMINALS TO FLOAT FREELY IN THE POCKET.
9. THIS TERMINAL IS DESIGNED FOR SINGLE WIRE CRIMPING
10. PART CONFORMS TO CLASS "B" REQUIREMENTS OF COSMETIC SPECIFICATION PS-45499-002
- △△ TEXT ON PART IS FOR REFERENCE ONLY. TEXT AND TEXT LOCATION MAY VARY DEPENDING ON PART NUMBER AND/OR TOOL.

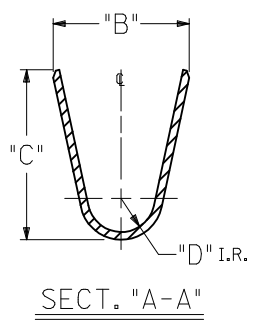
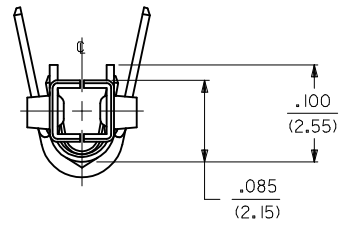

ADD TOL TO DIM D EC NO: UCP2017-2202 DRWING: BAPPELDORN 2017/07/26 CHKD: APPR: FSMITH 2017/09/29 REV: C5	QUALITY SYMBOLS	GENERAL TOLERANCES (UNLESS SPECIFIED)	DIMENSION STYLE	SCALE	DESIGN UNITS	THIRD ANGLE PROJECTION
	▽=0	mm INCH	IN/MM	10:1	METRIC	
	▽=0	4 PLACES ± --- ± ---	DRAWN BY	DATE	TITLE	HIGH CYCL'G TERM FEM CRIMP, MINI-FIT JR. BLANK-PLATE-FORM
	▽=0	3 PLACES ± .25 ± .010	CHECKED BY	DATE		
	▽=0	2 PLACES ± 0.25 ± .014	RJF	08/08/94		
	1 PLACE ± 0.36 ± ---	APPROVED BY	DATE			
	0 PLACE ± --- ± ---	FSMITH	2013/04/26			
	ANGULAR ±1/2°	MATERIAL NO.	SEE CHART	DOCUMENT NO.	SHEET NO.	
	DRAFT WHERE APPLICABLE MUST REMAIN WITHIN DIMENSIONS	SIZE	C	SD-44485-****	1 OF 2	
THIS DRAWING CONTAINS INFORMATION THAT IS PROPRIETARY TO MOLEX INCORPORATED AND SHOULD NOT BE USED WITHOUT WRITTEN PERMISSION						

ITEM NO.	WIRE GAGE	DIM. "B"	DIM. "C"	DIM. "D"	DIM. "E"	DIM. "F"	DIM. "G"
44485-1211	18-24 GA.	.142±.012	.177±.016	.035±.016	.075±.012	.091±.016	.020
44485-1212		(3.60±0.30)	(4.50±0.40)	(0.90±0.40)	(1.90±0.30)	(2.30±0.40)	(0.50)
X 44485-2211	22-28 GA.	.091±.012	.091±.016	.024±.016	.071±.012	.065±.016	.016
X 44485-2212		(2.30±0.30)	(2.30±0.40)	(0.60±0.40)	(1.80±0.30)	(1.65±0.40)	(0.40)
X 44485-3211	16 GA.	.142±.012	.177±.016	.035±.016	.091±.012	.106±.016	.024
X 44485-3212		(3.60±0.30)	(4.50±0.40)	(0.90±0.40)	(2.30±0.30)	(2.70±0.40)	(0.60)
X 44485-5211	28-30 GA.	.091±.012	.091±.016	.024±.016	.050±.010	.044±.010	.010
X 44485-5212		(2.30±0.30)	(2.30±0.40)	(.60 ±0.40)	(1.27±0.25)	(1.12±0.25)	(0.25)
X 44485-1311	18-24 GA.	.142±.012	.177±.016	.035±.016	.075±.012	.091±.016	.020
X 44485-1312		(3.60±0.30)	(4.50±0.40)	(0.90±0.40)	(1.90±0.30)	(2.30±0.40)	(0.50)
X 44485-2311	22-28 GA.	.091±.012	.091±.016	.024±.016	.071±.012	.065±.016	.016
X 44485-2312		(2.30±0.30)	(2.30±0.40)	(0.60±0.40)	(1.80±0.30)	(1.65±0.40)	(0.40)
X 44485-3311	16 GA.	.142±.012	.177±.016	.035±.016	.091±.012	.106±.016	.024
X 44485-3312		(3.60±0.30)	(4.50±0.40)	(0.90±0.40)	(2.30±0.30)	(2.70±0.40)	(0.60)
X 44485-5311	28-30 GA.	.091±.012	.091±.016	.024±.016	.050±.010	.044±.010	.010
X 44485-5312		(2.30±0.30)	(2.30±0.40)	(.60 ±0.40)	(1.27±0.25)	(1.12±0.25)	(0.25)
X 44485-1411	18-24 GA.	.142±.012	.177±.016	.035±.016	.075±.012	.091±.016	.020
X 44485-1412		(3.60±0.30)	(4.50±0.40)	(0.90±0.40)	(1.90±0.30)	(2.30±0.40)	(0.50)
X 44485-2411	22-28 GA.	.091±.012	.091±.016	.024±.016	.071±.012	.065±.016	.016
X 44485-2412		(2.30±0.30)	(2.30±0.40)	(0.60±0.40)	(1.80±0.30)	(1.65±0.40)	(0.40)
X 44485-3411	16 GA.	.142±.012	.177±.016	.035±.016	.091±.012	.106±.016	.024
X 44485-3412		(3.60±0.30)	(4.50±0.40)	(0.90±0.40)	(2.30±0.30)	(2.70±0.40)	(0.60)
X 44485-5411	28-30 GA.	.091±.012	.091±.016	.024±.016	.050±.010	.044±.010	.010
X 44485-5412		(2.30±0.30)	(2.30±0.40)	(.60 ±0.40)	(1.27±0.25)	(1.12±0.25)	(0.25)

LEGEND:

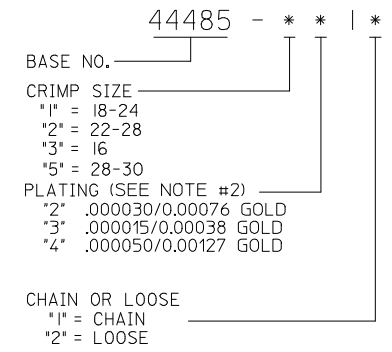

SEE SHEET 1 EC NO: UCP2017-2202 DRW: BAPPELDORN 2017/07/26 CHKD: APPR: FSMITH 2017/09/29	QUALITY SYMBOLS	GENERAL TOLERANCES (UNLESS SPECIFIED)	DIMENSION STYLE	SCALE	DESIGN UNITS	THIRD ANGLE PROJECTION
	▽=0	mm INCH	IN/MM	1:1	METRIC	
	▽=0	4 PLACES ± --- ± ---	DRAWN BY DATE	TITLE		
	▽=0	3 PLACES ± --- ±.010	CHECKED BY DATE	HIGH CYCL'G TERM FEM		
	▽=0	2 PLACES ± 0.25 ±.014	RJF 08/08/94	CRIMP, MINI-FIT JR.		
	1 PLACE ± 0.36 ± ---	APPROVED BY DATE	BLANK-PLATE-FORM			
	0 PLACE ± --- ± ---	FSMITH 2013/04/26	molex			
	ANGULAR ±1/2°	MATERIAL NO.	DOCUMENT NO.		SHEET NO.	
	DRAFT WHERE APPLICABLE MUST REMAIN WITHIN DIMENSIONS	SEE CHART	SD-44485-****		2 OF 2	
		SIZE	THIS DRAWING CONTAINS INFORMATION THAT IS PROPRIETARY TO MOLEX INCORPORATED AND SHOULD NOT BE USED WITHOUT WRITTEN PERMISSION			

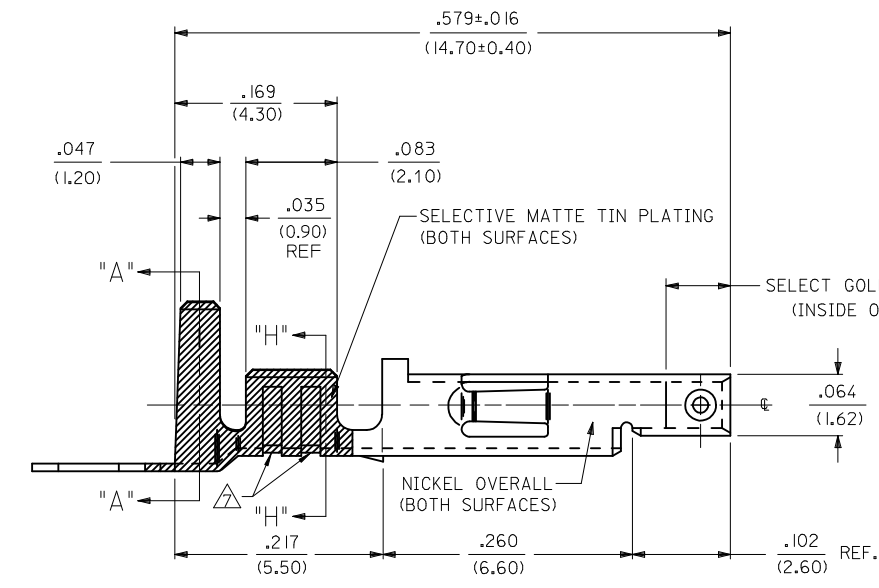
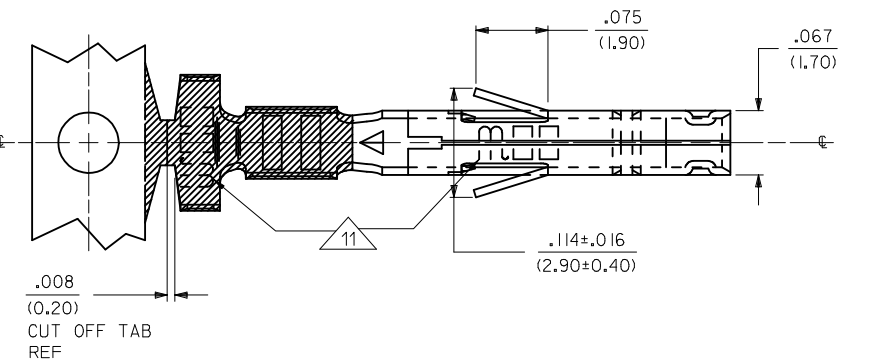

#18-24 TERMINAL SHOWN

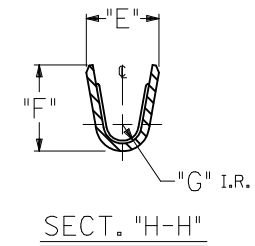
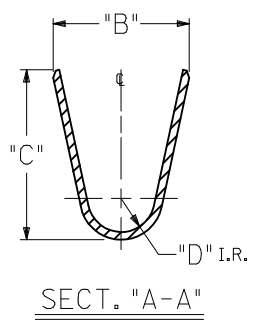

NOTES:

1. MATERIAL: PHOS. BRONZE
2. FINISH:
 - 2 = SELECTIVE GOLD PLATE .000030/(0.00076) MIN., AND SELECTIVE MATTE TIN .000100/(0.00254) OVER .000050/(0.00127) MIN. NICKEL OVERALL.
 - 3 = SELECTIVE GOLD PLATE .000015/(0.00038) MIN., AND SELECTIVE MATTE TIN .000080/(0.00203) OVER .000050/(0.00127) MIN. NICKEL OVERALL.
 - 4 = SELECTIVE GOLD PLATE .000050/(0.00127) MIN., AND SELECTIVE MATTE TIN .000100/(0.00254) OVER .000050/(0.00127) MIN. NICKEL OVERALL.
3. PRODUCT SPECIFICATION: SEE PSX-44485-0001.
4. PACKAGING SPECIFICATION: PK-44485-001 FOR CHAIN TERMINALS
PK-5556-003 FOR LOOSE TERMINALS
5. MATES WITH 5558, 5566 AND 5569 SERIES CONNECTORS.
6. TERMINAL FOR USE WITH 5557, 30067, 42474, 44516, SERIES HOUSINGS.
- △ THE NUMBER OF SERRATIONS TO BE ONE FOR WIRE RANGE #22-28
8. WHEN TERMINALS ARE INSTALLED IN THE HOUSING THE WIRES ARE TO BE DRESSED IN SUCH A MANNER TO ALLOW THE TERMINALS TO FLOAT FREELY IN THE POCKET.
9. THIS TERMINAL IS DESIGNED FOR SINGLE WIRE CRIMPING
10. PART CONFORMS TO CLASS "B" REQUIREMENTS OF COSMETIC SPECIFICATION PS-45499-002
- △△ TEXT ON PART IS FOR REFERENCE ONLY. TEXT AND TEXT LOCATION MAY VARY DEPENDING ON PART NUMBER AND/OR TOOL.

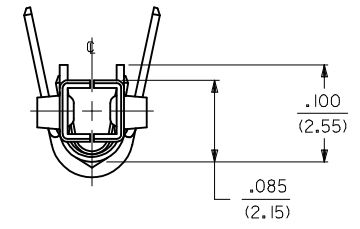

ADD TOL TO DIM D EC NO: UCP2017-2202 DRWING: BAPPELDORN 2017/07/26 CHKD: APPR: FSMITH 2017/09/29	QUALITY SYMBOLS	GENERAL TOLERANCES (UNLESS SPECIFIED)	DIMENSION STYLE	SCALE	DESIGN UNITS	THIRD ANGLE PROJECTION
	▽=0	mm INCH	IN/MM	10:1	METRIC	
	▽=0	4 PLACES ± --- ± ---	DRAWN BY	DATE	TITLE	HIGH CYCL'G TERM FEM CRIMP, MINI-FIT JR. BLANK-PLATE-FORM molex DOCUMENT NO. SD-44485-**** SHEET NO. 1 OF 2
	▽=0	3 PLACES ± --- ±.010	CHECKED BY	DATE		
	▽=0	2 PLACES ± 0.25 ±.014	RJF	08/08/94		
	1 PLACE ± 0.36 ± ---	APPROVED BY	DATE			
	0 PLACE ± --- ± ---	FSMITH	2013/04/26			
C5	ANGULAR ±1/2°	DRAFT WHERE APPLICABLE MUST REMAIN WITHIN DIMENSIONS	SEE CHART			

ITEM NO.	WIRE GAGE	DIM. "B"	DIM. "C"	DIM. "D"	DIM. "E"	DIM. "F"	DIM. "G"
44485-1211	18-24 GA.	.142±.012	.177±.016	.035±.016	.075±.012	.091±.016	.020
44485-1212		(3.60±0.30)	(4.50±0.40)	(0.90±0.40)	(1.90±0.30)	(2.30±0.40)	(0.50)
X 44485-2211	22-28 GA.	.091±.012	.091±.016	.024±.016	.071±.012	.065±.016	.016
X 44485-2212		(2.30±0.30)	(2.30±0.40)	(0.60±0.40)	(1.80±0.30)	(1.65±0.40)	(0.40)
X 44485-3211	16 GA.	.142±.012	.177±.016	.035±.016	.091±.012	.106±.016	.024
X 44485-3212		(3.60±0.30)	(4.50±0.40)	(0.90±0.40)	(2.30±0.30)	(2.70±0.40)	(0.60)
X 44485-5211	28-30 GA.	.091±.012	.091±.016	.024±.016	.050±.010	.044±.010	.010
X 44485-5212		(2.30±0.30)	(2.30±0.40)	(.60 ±0.40)	(1.27±0.25)	(1.12±0.25)	(0.25)
X 44485-1311	18-24 GA.	.142±.012	.177±.016	.035±.016	.075±.012	.091±.016	.020
X 44485-1312		(3.60±0.30)	(4.50±0.40)	(0.90±0.40)	(1.90±0.30)	(2.30±0.40)	(0.50)
X 44485-2311	22-28 GA.	.091±.012	.091±.016	.024±.016	.071±.012	.065±.016	.016
X 44485-2312		(2.30±0.30)	(2.30±0.40)	(0.60±0.40)	(1.80±0.30)	(1.65±0.40)	(0.40)
X 44485-3311	16 GA.	.142±.012	.177±.016	.035±.016	.091±.012	.106±.016	.024
X 44485-3312		(3.60±0.30)	(4.50±0.40)	(0.90±0.40)	(2.30±0.30)	(2.70±0.40)	(0.60)
X 44485-5311	28-30 GA.	.091±.012	.091±.016	.024±.016	.050±.010	.044±.010	.010
X 44485-5312		(2.30±0.30)	(2.30±0.40)	(.60 ±0.40)	(1.27±0.25)	(1.12±0.25)	(0.25)
X 44485-1411	18-24 GA.	.142±.012	.177±.016	.035±.016	.075±.012	.091±.016	.020
X 44485-1412		(3.60±0.30)	(4.50±0.40)	(0.90±0.40)	(1.90±0.30)	(2.30±0.40)	(0.50)
X 44485-2411	22-28 GA.	.091±.012	.091±.016	.024±.016	.071±.012	.065±.016	.016
X 44485-2412		(2.30±0.30)	(2.30±0.40)	(0.60±0.40)	(1.80±0.30)	(1.65±0.40)	(0.40)
X 44485-3411	16 GA.	.142±.012	.177±.016	.035±.016	.091±.012	.106±.016	.024
X 44485-3412		(3.60±0.30)	(4.50±0.40)	(0.90±0.40)	(2.30±0.30)	(2.70±0.40)	(0.60)
X 44485-5411	28-30 GA.	.091±.012	.091±.016	.024±.016	.050±.010	.044±.010	.010
X 44485-5412		(2.30±0.30)	(2.30±0.40)	(.60 ±0.40)	(1.27±0.25)	(1.12±0.25)	(0.25)

LEGEND:

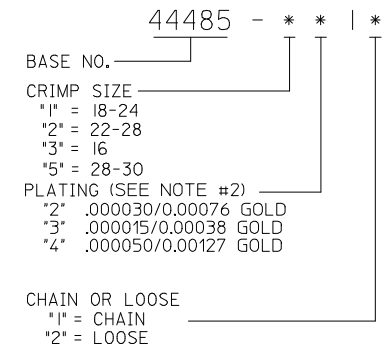

SEE SHEET 1 EC NO: UCP2017-2202 DRWNG:APPELDORN 2017/07/26 CHKD: APPR:FSMITH 2017/09/29	QUALITY SYMBOLS	GENERAL TOLERANCES (UNLESS SPECIFIED)	DIMENSION STYLE	SCALE	DESIGN UNITS	THIRD ANGLE PROJECTION
	▽=0	mm INCH	IN/MM	1:1	METRIC	☉
	▽=0	4 PLACES ± --- ± ---	DRAWN BY DATE	TITLE		
	▽=0	3 PLACES ± --- ±.010	GEP 08/08/94	HIGH CYCL'G TERM FEM		
	▽=0	2 PLACES ± 0.25 ±.014	CHECKED BY DATE	CRIMP, MINI-FIT JR.		
	1 PLACE ± 0.36 ± ---	RJF 08/08/94	BLANK-PLATE-FORM			
	0 PLACE ± --- ± ---	APPROVED BY DATE	molex			
	ANGULAR ±1/2°	FSMITH 2013/04/26	MATERIAL NO.	DOCUMENT NO.	SHEET NO.	
	DRAFT WHERE APPLICABLE MUST REMAIN WITHIN DIMENSIONS		SEE CHART	SD-44485-****	2 OF 2	
			THIS DRAWING CONTAINS INFORMATION THAT IS PROPRIETARY TO MOLEX INCORPORATED AND SHOULD NOT BE USED WITHOUT WRITTEN PERMISSION			