



THG03

CO₂ Temp. & Humidity Transmitter(Indoor)

| Features |

- Integrated 3 sensors in 1 device with LCD display
- Measuring temperature, humidity and carbon dioxide
- 2 analog outputs and Modbus RS-485
- Optional analog output + RS-485
- Quick easy installation and maintenance due to well designed
- Cost-efficient and reliable
- Data can be logged and transferred to PC via RS-485 function link free software

| Applications |

Monitoring the air quality in indoor environments / HVAC / Air conditioning / Museums / Greenhouse /
Testing environments work places / Supermarkets / Data centers / Production warehouses /
Indoor public / Places to regulate the ventilation system to save energy

| Specification |

Display

Display	LCD module without backlight
Display readout	Double line character (Up : CO ₂ / Down : T&H take turns)
Digit	CO ₂ : 4 digits / T&H : 3 digits&1 decimal
Digit height	17.84 mm

Input

CO ₂	NDIR sensor
Temp. & humidity	MEMS sensor

Measuring range

CO ₂	0 ... 2000 PPM
Temperature	0 ... 50°C
Humidity	0 ... 100%RH(Non-condensing)

Output

Analog output	0 ... 10 V / 4 ... 20 mA
Modbus	RS-485
Signal connection	3-wire
Load resistance	Voltage output : $\geq 100 \text{ K}\Omega$ Current output : $< 250 \text{ }\Omega$
Warm-up time	$< 2 \text{ min}$, stable time 20 min
Temp. influence	T&H : Max. $-0.15\% \text{RH}/^\circ\text{C}$ (0 ... 80°C)
Response time	CO ₂ : $t_{90} < 2 \text{ min}$ T&H : $t_{63}(15 \dots 45^\circ\text{C} / 33 \dots 75\% \text{RH}) \leq 10 \text{ sec}$
Sampling time	CO ₂ : About 6 sec / T&H : About 3 sec
Data logger	Via RS-485 by using eyc free software

***Please make sure the product and the device which connect with RS-485 are on common ground, avoid damaged product.**

Accuracy(at +25°C ; DC 24 V ; 101.3 kPa)

CO ₂	$\pm 40 \text{ PPM} \pm 3\%$ of reading
Temperature	$\pm 0.5^\circ\text{C}$
Humidity	$\pm 5\% \text{RH}$ (30 ... 80%RH)

Environment

Medium	Air
Operating Temp. / Humid.	T&H : 0 ... 50°C / 0 ... 100%RH(Non-condensing)
Operating Temp. / Humid.	CO ₂ : 0 ... 50°C / 0 ... 85%RH
Storage temperature	-20 ... +60°C

Electrical

Power supply	DC 24 V $\pm 10\%$ & AC 24 V $\pm 10\%$
Current consumption	DC : 150 mA / AC : 120 mA
Starting current	DC 24 V : 250 mA AC 24 V : 230 mA
Electrical connection	Analog & communication : 4P connector

Installation

Installation	Indoor and wall mount
--------------	-----------------------

Protection

IP rating	IP20
Electrical protection	■ Polarity protection ■ Short-circuit

Certification

Certification	CE
---------------	----

Material

Housing	PC(PC-110)(UL94V-2)
Weight	100 g

| Dimension |

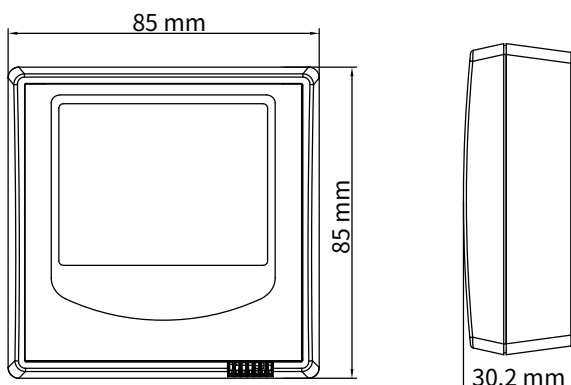

| Diagram |

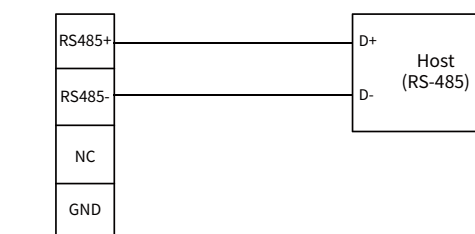
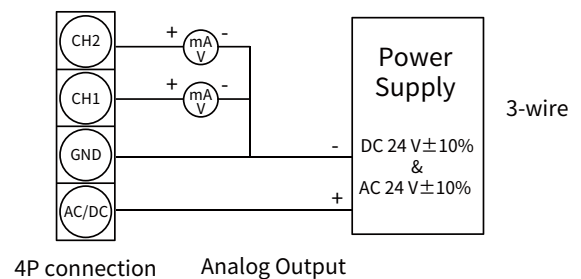

4P connection

RS-485

| Ordering Guide |

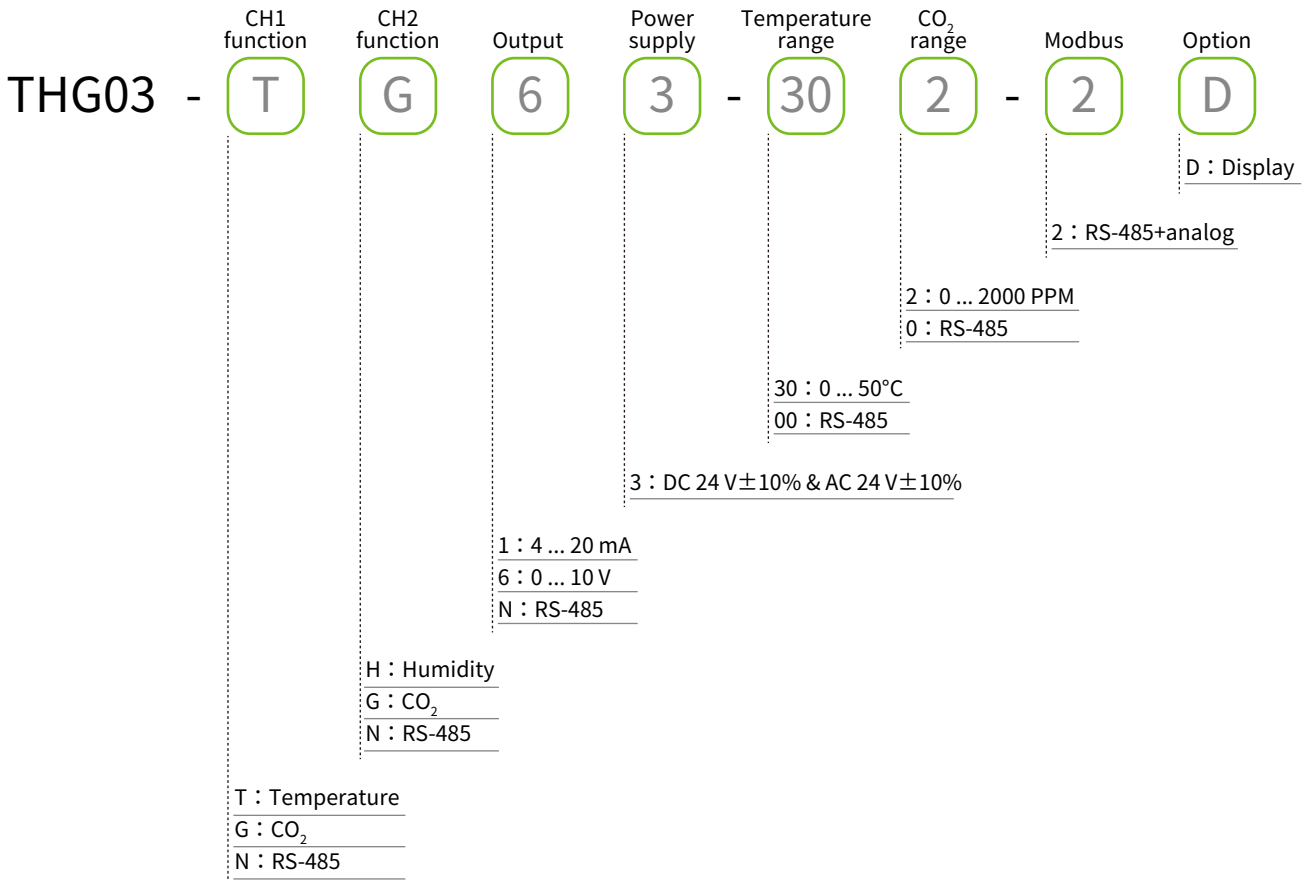

| Additional Option Test Report |

For more detailed information please contact us.

■ ILAC / TAF

YUDEN-TECH CO.,LTD. Calibration Laboratory - (ILAC / TAF) Test report.
 (TAF accreditation:3032, complying with ISO / IEC 17025) TAF has mutual recognition arrangement with ILAC MRA

Project	Measurand level or range
Hygrometer	Temperature : 0°C ... 69.5°C
	Humidity : 10% ... 95%

■ ISO 9001

Project	Measurand level or range
Temperature and Humidity	Temperature : 0°C ... 200°C
	Humidity : 0.1% ... 99.8%