

REVISIONS				
P	LTR	DESCRIPTION	DATE	APVD
	B	REVISED PER ECO-19-009164	23JUN2020	SJ DR

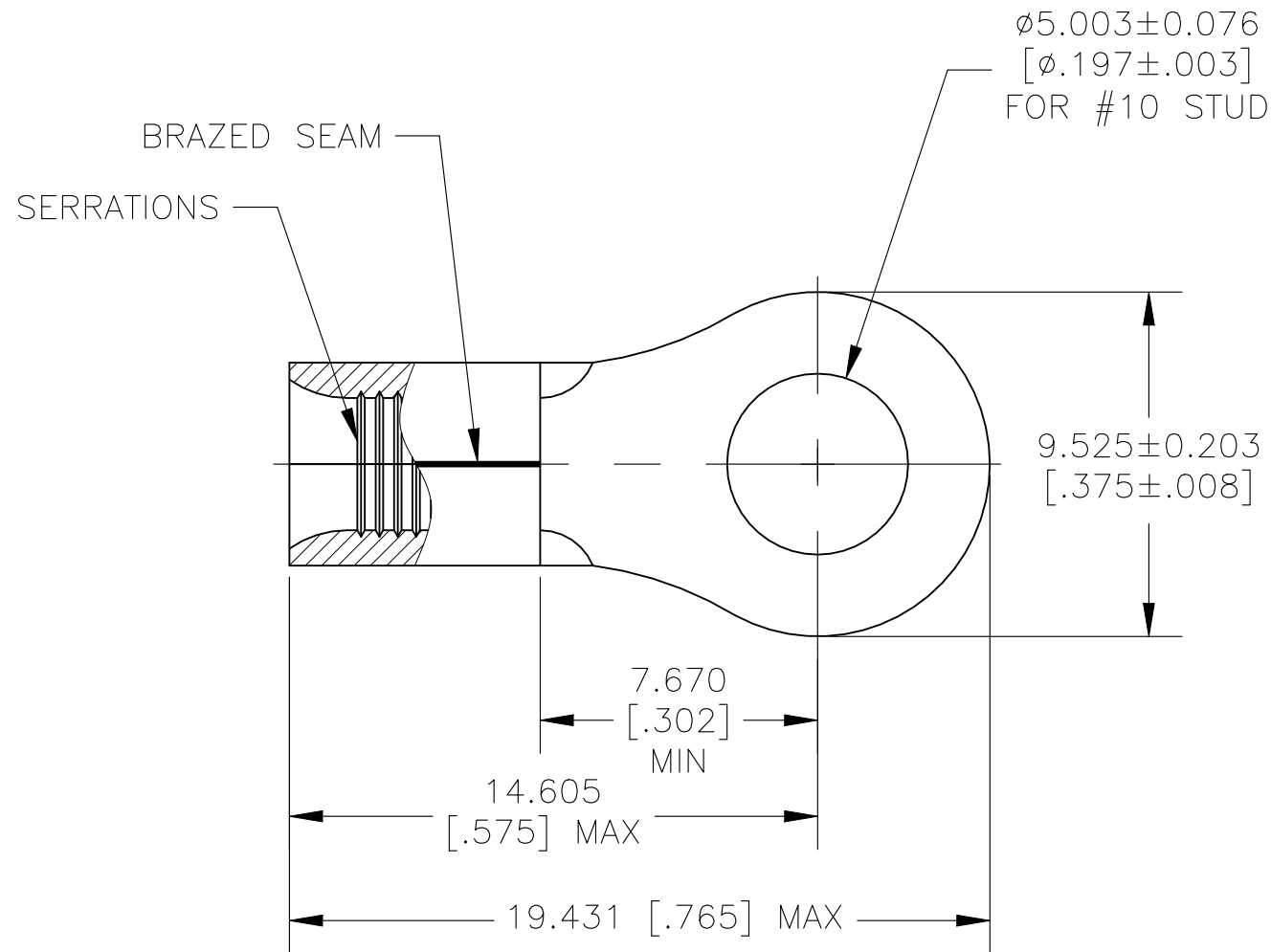

1. WIRE RANGE: 12-10 AWG. STANDARD WIRE CROSS SECTIONAL AREA RANGE: 5,180-13,100 CIRCULAR MILS, STRANDED
2. TERMINAL BODY MATERIAL THK IS 0.990±0.0762 [.039±.003]
3. RECOMMENDED OPERATING TEMP -55°C(-67°F) TO +200°C(392°F) FOR HEAT SHRINK TUBING.
4. HEAT SHRINK TUBING SHELF LIFE OF 18 MONTHS FROM DATE CODE ON LABEL.

△ 5 TERMINAL BODY PRODUCT SPECIFICATION 108-32046. APPLICATION SPECIFICATION 114-2162.

1	2-1197130-7	HIGH AND LOW TEMPERATURE CROSS LINKED FLUOROPOLYMER HEAT SHRINK TUBING 6.35 [.250] MIN ID X 25.40±2.03 [1.000±.080], RT-555-1/4-0-SP
1	323062	TERMINAL BODY: COPPER PER ASTM B152 ANNEALED FINISH: NICKEL PLATE 0.00762 [.000300] MIN EXT THK PER SAE AMS QQ-N-290
-1	PART NO	DESCRIPTION

THIS DRAWING IS A CONTROLLED DOCUMENT.		DWN JR RUTH 06JUN07	<b>STE</b> TE Connectivity													
DIMENSIONS: MM [ INCHES ]		CHK MJ SPICER 06JUN07														
TOLERANCES UNLESS OTHERWISE SPECIFIED:		APVD MJ SPICER 06JUN07	NAME HEAT RESISTANT TERMINAL KIT WIRE SIZE: 12-10 AWG													
<table border="0"> <tr> <td>0 PLC</td> <td>± -</td> </tr> <tr> <td>1 PLC</td> <td>± -</td> </tr> <tr> <td>2 PLC</td> <td>± -</td> </tr> <tr> <td>3 PLC</td> <td>± 0.127 [.005]</td> </tr> <tr> <td>4 PLC</td> <td>± -</td> </tr> <tr> <td>ANGLES</td> <td>± 1°</td> </tr> </table>		0 PLC	± -	1 PLC	± -	2 PLC	± -	3 PLC	± 0.127 [.005]	4 PLC	± -	ANGLES	± 1°	PRODUCT SPEC - △ 5	SIZE A3	
0 PLC	± -															
1 PLC	± -															
2 PLC	± -															
3 PLC	± 0.127 [.005]															
4 PLC	± -															
ANGLES	± 1°															
MATERIAL SEE TABLE		APPLICATION SPEC - △ 5	CAGE CODE 00779	DRAWING NO C-1958125												
FINISH SEE TABLE		WEIGHT -	RESTRICTED TO -													
CUSTOMER DRAWING			SCALE 1:1	SHEET 1 OF 1												
			REV B													