

PART NAME	NEMA 4X ENCLOSURE	PART No.	PN-1334, PN-1334-C AND PN-1334-DG PNR-2604, PNR-2604-C AND PNR-2604-DG	REV. DATE	11-17-08
-----------	-------------------	----------	---	-----------	----------

INDUSTRY STANDARDS:
 POLYCARBONATE (LIGHT GRAY AND CLEAR)
 UL94-HB FLAMMABILITY RATING (UL FILE #E41613)
 UV STABILIZED
 SERVICE TEMPERATURE RANGE: -40°C TO +120°C
 ABS (DARK GRAY)
 UL94-HB FLAMMABILITY RATING (UL FILE #E56070)
 SERVICE TEMPERATURE RANGE: -40°C TO +80°C

PART NUMBER	DIMENSION		
	A	B	C
PN-1334, PN-1334-C AND PN-1334-DG	0.591	0.120	2.958
PNR-2604, PNR-2604-C AND PNR-2604-DG	1.180	0.710	3.547

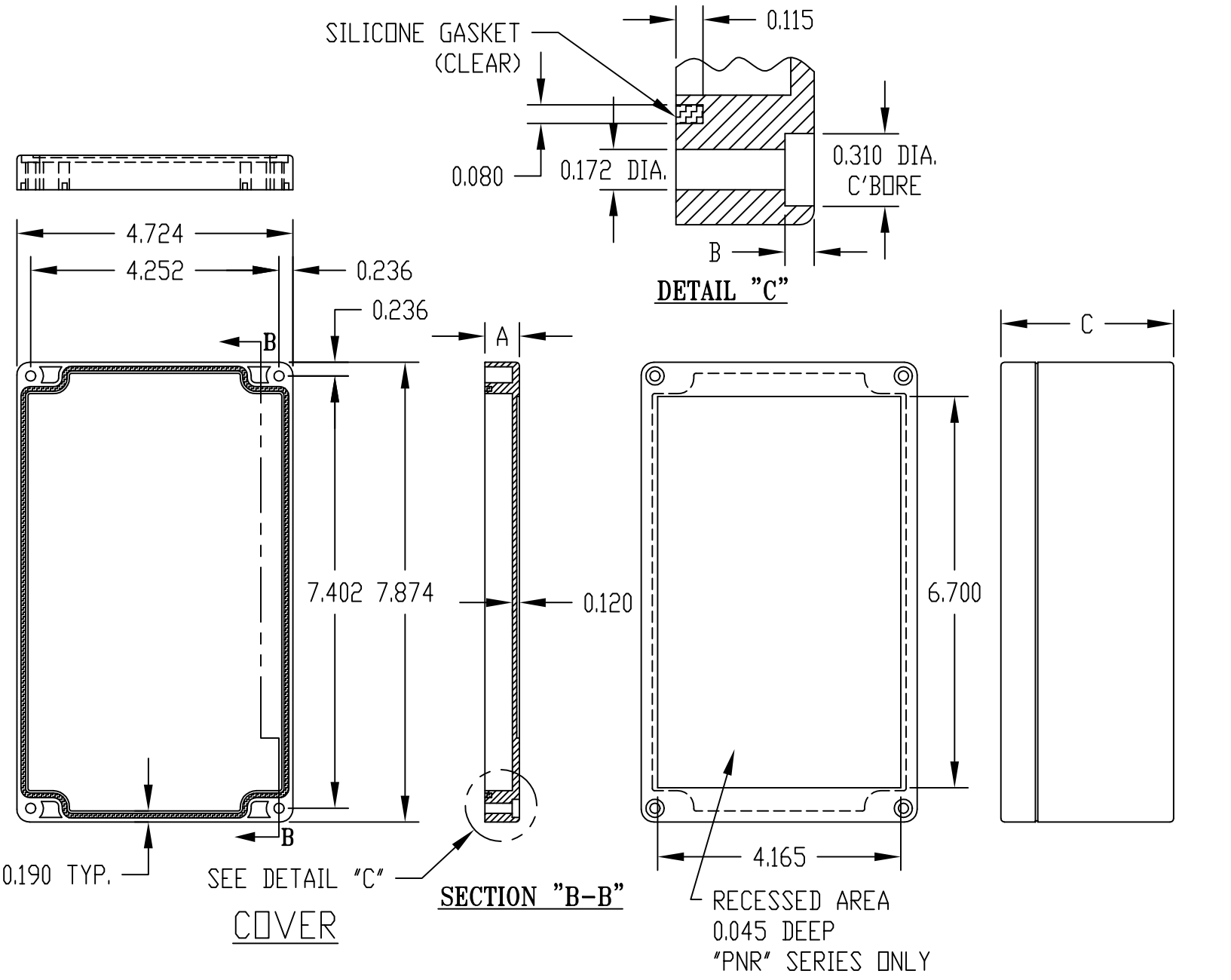
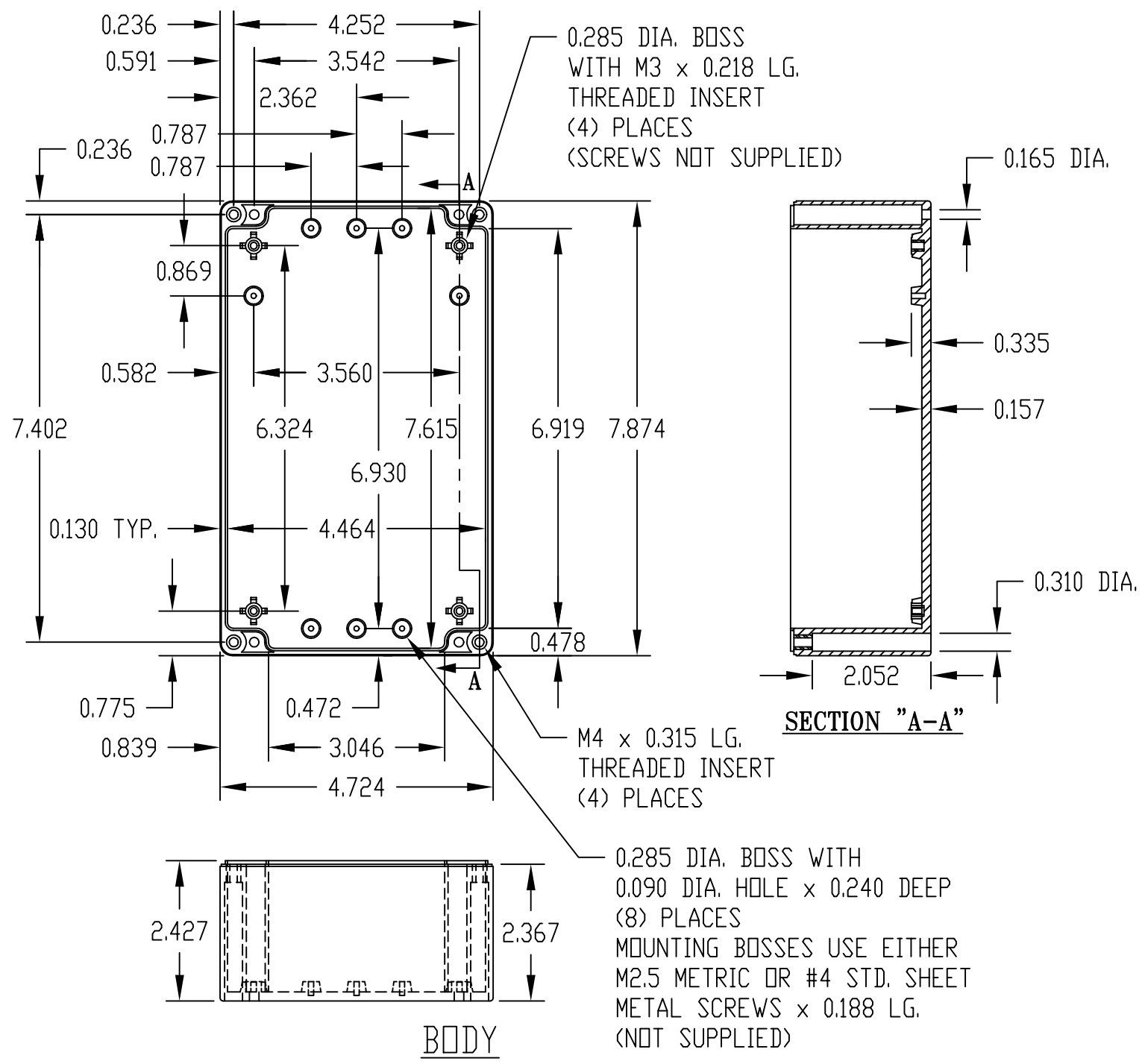

NOTE: ALL DIMENSIONS HAVE ±0.015 TOLERANCE UNLESS OTHERWISE SPECIFIED.

PART NUMBER	MATERIAL		FINISH		HARDWARE KIT
	BODY	COVER	BODY	COVER	
PN-1334 & PNR-2604	POLYCARBONATE		LIGHT GRAY		KIT CONTAINS (4) M4 x 20mm (0.787") LG. SCREWS FOR ASSEMBLY
PN-1334-C & PNR-2604-C	POLYCARBONATE		LIGHT GRAY	CLEAR	
PN-1334-DG & PNR-2604-DG	HIGH-IMPACT ABS		DARK GRAY		