

PART NAME: KNOB SCALE: 1:1 DATE: 11/25/97 DR. BY HD

THIS DRAWING IS THE PROPERTY OF DAVIES MOLDING COMPANY, IS SUBMITTED SOLELY AS A DESIGN OR ENGINEERING PROJECT. WE ACCEPT NO RESPONSIBILITY WHATSOEVER FOR THE PRACTICAL APPLICATION OF THE PIECES MADE TO THIS DESIGN.



DESIGNERS & MANUFACTURERS OF KNOBS, HANDLES, CASES & CUSTOM PLASTIC COMPONENTS

P/N 3087AC

M NO. # 24 (PRESS 751)

CAVITY	3087
CORE	3087
CAVITY PLUG	3087
BUSHING	3087-L
PIN	3087-L1
INSERT	I2094

ROTARY SET-UP

M NO. # 117

CAVITY	3087 (B CAV. BLOCK)
CORE	3087 (B CORE BLOCK)
TOP PIN	3087
SLEEVE	3087-G
BOTTOM PIN	3087AG
INSERT	I2094

R0.25 [R6.35](2)

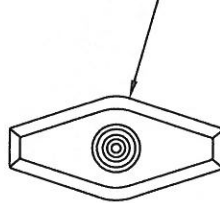

R0.03 [R0.79] TYP.

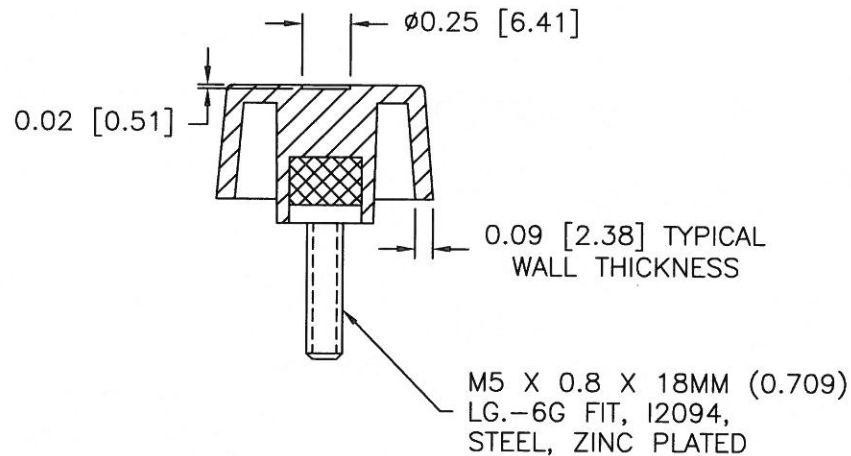
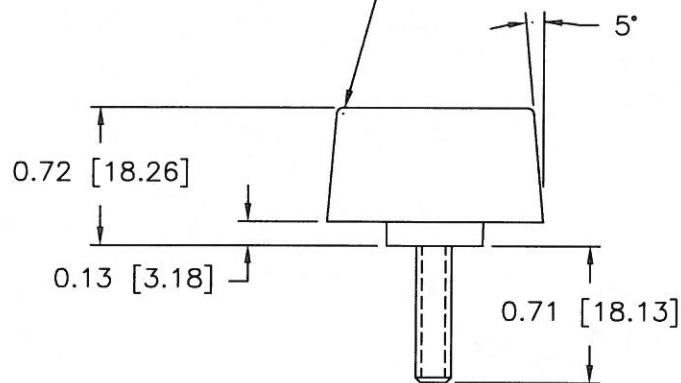

∅0.50 [∅12.70]

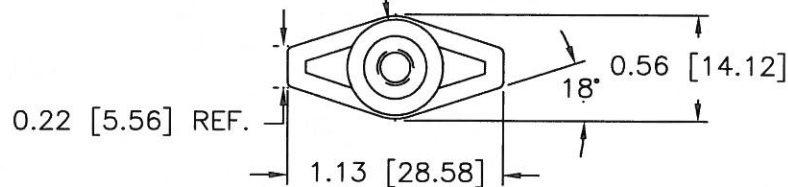

ⓑ

MATERIAL: NYLON 6/6 (ZY2), (ZY6)
OR ENGINEERING APPROVED EQUIVALENT

COLOR: BLACK

Ⓐ

TOLERANCES: UNLESS OTHERWISE SPECIFIED	DO NOT SCALE DRAWING				
		B	WAS CLC, ADDED ZY6	JAM	6/25/12
DECIMALS: X.XXX ± .005 X.XX ± .015	MM: X.XX ± 0.15MM X.X ± 0.4MM	A	ADDED MAT. CODE	DS	1/8/07
		-	CORRECTED TOOLING BOX AND PART APPEARANCE	TS	6/26/02
FRACTIONS ± 1/64	ANG. ± 1°	CHANGES			