

# Single Output, Low Power Programmable Clock Generator for Portable Applications

## Features

- Small footprint, 8-Pin QFN 1.7 mm x 1.7 mm x 0.6 mm package
- Low power and low jitter operation
- Multiple operating voltages:
  - CY22M1S: 2.5 V, 3.0 V, or 3.3 V
  - CY22M1L: 1.8 V
- Programmable single output clock generator frequency range:
  - 1 to 80 MHz
- Crystal or external reference clock input frequency range:
  - Fundamental tuned crystal: 8 to 48 MHz
  - External reference clock: 1 to 80 MHz
- Programmable capacitor tuning array
- Programmable PD# or OE Control pin
- Programmable asynchronous or synchronous OE and PD# Modes
- Programmable output buffer drive strength

## Benefits

- Services handsets, portable media players, personal navigation devices, digital cameras, digital camcorders, and other portable applications.
- Saves PCB space due to small form factor.
- Enables quick turnaround as well as flexibility and adaptability to design changes through programmability.
- Enables synthesis of highly accurate and stable output clock frequencies with zero or low PPM error.
- Enables fine tuning of output clock frequency by adjusting the crystal load  $C_{Load}$  using programmable internal capacitors.
- Lowers clock solution cost by pairing a high frequency PLL programmability with a low cost, low frequency crystal.
- Enables low power during the power down or output disable function.
- Provides flexibility for system applications through selectable asynchronous or synchronous output enable and disable.

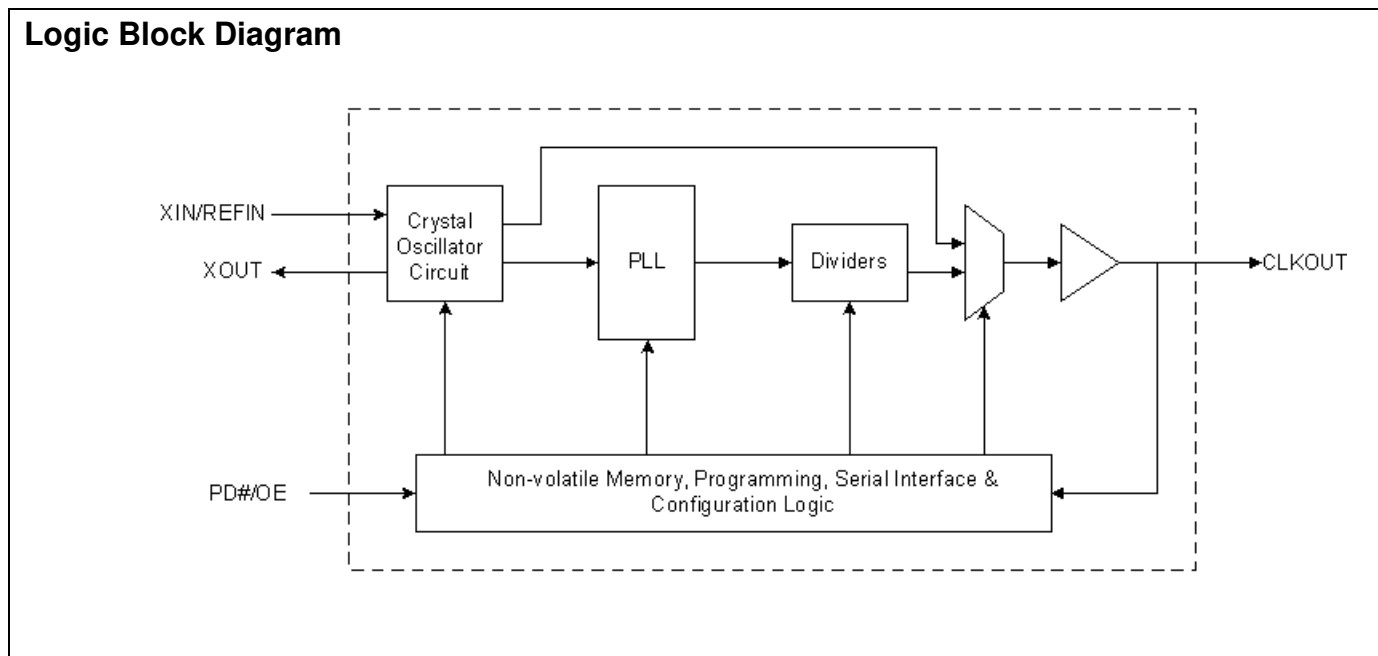

**Contents**

<b>Pin Description</b> .....	<b>3</b>	<b>for SMD Package</b> .....	<b>9</b>
<b>Functional Description</b> .....	<b>4</b>	<b>Switching Waveforms</b> .....	<b>9</b>
Configurable PLL .....	4	<b>Ordering Information</b> .....	<b>11</b>
Input Reference Clock Option .....	4	Possible Configurations .....	11
Multiple VDD Power Supply Option .....	4	Ordering Code Definitions .....	11
Programmable Output Drive Strength .....	4	<b>Package Drawing and Dimensions</b> .....	<b>12</b>
Power Management Feature .....	4	<b>Acronyms</b> .....	<b>13</b>
<b>Crystal Oscillator Tuning Circuit</b> .....	<b>5</b>	<b>Document Conventions</b> .....	<b>13</b>
<b>Programmable Features</b> .....	<b>5</b>	Units of Measure .....	13
<b>Programming Support</b> .....	<b>5</b>	<b>Document History Page</b> .....	<b>14</b>
<b>Absolute Maximum Ratings</b> .....	<b>6</b>	<b>Sales, Solutions, and Legal Information</b> .....	<b>15</b>
<b>Recommended Operating Conditions</b> .....	<b>6</b>	Worldwide Sales and Design Support .....	15
<b>DC Electrical Specifications</b> .....	<b>7</b>	Products .....	15
<b>AC Electrical Specifications</b> .....	<b>8</b>	PSoC® Solutions .....	15
<b>Recommended Crystal Specifications</b>			

**Pin Description**

**Figure 1. Package Pinout Drawing: CY22M1 8-Pin 1.7 mm x 1.7 mm QFN**

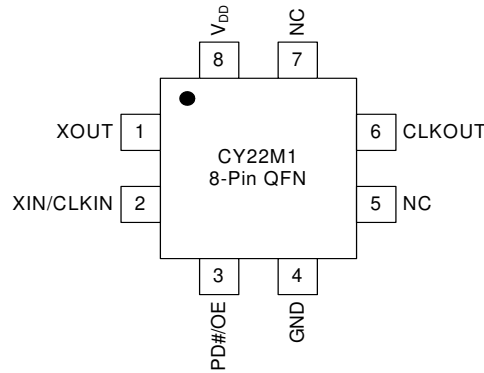

**Table 1. Pin Definition: CY22M1 8-Pin 1.7 mm x 1.7 mm QFN**

Pin Number	Name	IO	Description
1	XOUT	Output	Crystal output. Float for external clock input.
2	XIN/CLKIN	Input	Crystal or external clock input.
3	PD#/OE	Input	Multifunction pin. Active low power down or active high output enable pin. Has weak internal pull-up.
4	GND	Power	Power supply ground.
5	NC	–	No connect. Pin has no internal connection.
6	CLKOUT	Output	Programmable clock output. Output voltage depends on $V_{DD}$ . Has weak internal pull-down.
7	NC	–	No connect. Pin has no internal connection.
8	$V_{DD}$	Power	Programmable power supply: CY22M1S: 2.5 V, 3.0 V, 3.3 V (standard voltage) CY22M1L: 1.8 V (low voltage)

## Functional Description

The Part Number is a programmable, high accuracy, PLL-based clock generator device designed for low power, space constrained applications. The low jitter and accurate outputs makes this device suitable for handsets, portable media players, personal navigation devices, digital cameras, digital camcorders, and other portable applications.

The device has several programmable options listed in the section [Programmable Features on page 5](#) of this data sheet. The entire configuration is one time programmable.

### Configurable PLL

The device uses a programmable PLL to generate output frequencies from 1 to 80 MHz. The high resolution of the PLL and flexible output dividers provide this flexibility.

### Input Reference Clock Option

There is an option of a crystal or clock signal for the input reference clock. The frequency range for crystal (XIN) is 8 MHz to 48 MHz, while the range for an external reference clock (CLKIN) is 1 MHz to 80 MHz. A PLL bypass mode enables this device to be used as a crystal oscillator.

### Multiple V<sub>DD</sub> Power Supply Option

The device has programmable power supply options. The operating supply voltages are 2.5 V, 3.0 V, or 3.3 V for CY22M1S and 1.8 V for CY22M1L.

### Programmable Output Drive Strength

The DC drive strength of the clock output can be programmed to one of two settings, enabling control of output rise and fall times. [Table 2](#) shows the typical rise and fall times for both of the drive strength settings.

**Table 2. Output Drive Strength**

Output Drive Strength	Rise/Fall Time (ns) (Typical Value)
Low	2.0
High	1.0

### Power Management Feature

The Part Number offers PD# (active LOW) and OE (active HIGH) functions. When the power down mode is selected (PD# =0), the oscillator and PLL are placed in a low supply current standby mode and the output is tristated and weakly pulled LOW. The oscillator and PLL circuits must relock when the part exits the power down mode. If the output is disabled (OE=0), the output is tristated and weakly pulled LOW. In this mode, the oscillator and PLL circuits continue to operate, which enables a rapid return to normal operation when the output is enabled.

In addition, the PD# or OE mode can be programmed to occur asynchronously or synchronously with respect to the output signal. When the asynchronous setting is used, entering power down or disabling the output occurs immediately (enabling logic delays) regardless of the position in the clock cycle. Similarly, exiting power down or enabling the output occurs immediately with no guarantee of full output clock pulses. However, when the synchronous setting is used, the part waits for a falling edge at the output before entering power down or disabling the output. This prevents output glitches. The first output pulse is guaranteed to be a full clock pulse when enabling outputs with a synchronous OE pin. The first output pulse is not guaranteed to be a full clock when exiting power down in synchronous or asynchronous mode.

### Output Frequency Tuning

The Part Number contains an on-chip oscillator with a built-in programmable capacitor array for fine tuning of the output frequency. The capacitive load seen by the crystal is adjusted by programming the memory bits. This feature can compensate for crystal variations or provide a more accurate synthesized frequency. [Figure 2 on page 5](#) shows the crystal oscillator tuning circuit block diagram.

## Crystal Oscillator Tuning Circuit

Table 3. Crystal Oscillator Tuning Capacitor Values

Cap	Value <sup>[1]</sup>	Unit
C <sub>7</sub>	5.000	pF
C <sub>6</sub>	2.500	pF
C <sub>5</sub>	1.250	pF
C <sub>4</sub>	0.625	pF
C <sub>3</sub>	0.313	pF
C <sub>2</sub>	0.156	pF
C <sub>1</sub>	0.078	pF
C <sub>0</sub>	0.039	pF

Figure 2. Crystal Oscillator Tuning Block Diagram

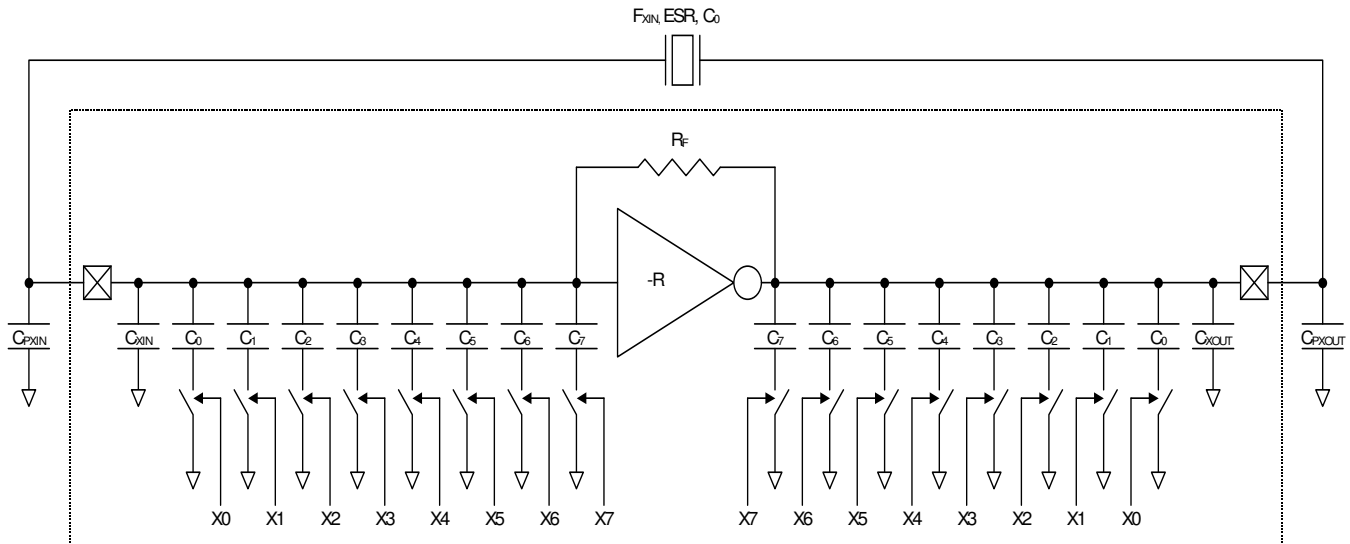

### Programmable Features

The following list of features can be custom configured:

- PLL frequency and output divider value
- Oscillator tuning (crystal load) capacitance value
- Direct oscillator output (PLL bypass)
- High or low power supply voltage operation
- Power management mode (OE or PD#)
- Power management timing (synchronous or asynchronous)
- Programmable output drive strength

### Programming Support

The device is available in factory and field programmable versions. The CyClockMaker Programming kit ([CY3675-CLKMAKER1](#)) along with [CyClockWizard](#) configuration software is used for field programming the device. For specific programming needs, contact your local Cypress field application engineer (FAE) or sales representative.

**Note**

1. The capacitor values are nominal

## Absolute Maximum Ratings

Parameter <sup>[2]</sup>	Description	Condition	Min	Max	Unit
V <sub>DD</sub>	Supply voltage, 2.5 V/3.0 V/3.3 V range	–	–0.5	4.4	V
	Supply voltage, 1.8 V range	–	–0.5	2.8	V
V <sub>IN</sub>	Input voltage	Relative to V <sub>SS</sub>	–0.5	V <sub>DD</sub> +0.5	V
T <sub>S</sub>	Temperature, storage	Non functional	–55	+125	°C
T <sub>J</sub>	Temperature, junction	Non functional	–40	+125	°C
ESD <sub>HBM</sub>	ESD protection (human body model)	JEDEC EIA/JESD22-A114-E	2000	–	Volts
D <sub>RET</sub>	Data retention at T <sub>J</sub> = 125°C	–	10	–	Yr.
PR <sub>CYCLE</sub>	Maximum programming cycle	–	1		
UL-94	Flammability rating	–	V-0 at 1/8 in.		
MSL	Moisture sensitivity level	–	3		

## Recommended Operating Conditions

Parameter <sup>[2]</sup>	Description	Min	Typ	Max	Unit
V <sub>DD</sub>	Supply voltage, 1.8 V operating range for CY22M1L	1.6	–	2.0	V
	Supply voltage, 2.5 V operating range for CY22M1S	2.2	–	2.8	V
	Supply voltage, 3.0 V operating range for CY22M1S	2.7	–	3.3	V
	Supply voltage, 3.3 V operating range for CY22M1S	3.0	–	3.6	V
T <sub>AC</sub>	Commercial ambient temperature	0	–	70	°C
T <sub>AI</sub>	Industrial ambient temperature	–40	–	85	°C
T <sub>PU</sub>	Power up time for V <sub>DD</sub> to reach minimum specified voltage (power ramp must be monotonic)	0.05	–	500	ms
T <sub>PD</sub>	Minimum pulse width of PD#/OE input	100	–	–	ns
C <sub>OUT</sub>	Output load capacitance	–	–	15	pF

### Note

2. Stresses beyond those listed under [Absolute Maximum Ratings](#) may cause permanent damage to the device. These are stress ratings only, and functional operation of the device at these or any other conditions beyond those indicated under [Recommended Operating Conditions](#) is not implied. Exposure to Absolute-Maximum-Rated Conditions for extended periods may affect device reliability or cause permanent device damage

**DC Electrical Specifications**

Parameter <sup>[3]</sup>	Description	Test Conditions	Min	Typ	Max	Unit
V <sub>IL1</sub>	Input low voltage of PD#/OE	–	–	–	0.2*V <sub>DD</sub>	V
V <sub>IH1</sub>	Input high voltage of PD#/OE	–	0.8*V <sub>DD</sub>	–	–	V
V <sub>IL2</sub>	Input low voltage of REFIN	CY22M1S	-0.2	–	0.4	V
		CY22M1L	-0.2	–	0.4	V
V <sub>IH2</sub>	Input high voltage of REFIN	CY22M1S	1.2	–	2.1	V
		CY22M1L	1.2	–	V <sub>DD</sub> +0.3 <sup>[4]</sup>	V
V <sub>OL1</sub>	Output low voltage	I <sub>OL</sub> = 8 mA, V <sub>DD</sub> = 3.0/3.3 V	–	–	0.4	V
V <sub>OH1</sub>	Output high voltage	I <sub>OH</sub> = 8 mA, V <sub>DD</sub> = 3.0/3.3 V	V <sub>DD</sub> -0.4	–	–	V
V <sub>OL2</sub>	Output low voltage	I <sub>OL</sub> = 4 mA, V <sub>DD</sub> = 1.8/2.5 V	–	–	0.1*V <sub>DD</sub>	V
V <sub>OH2</sub>	Output high voltage	I <sub>OH</sub> = 4 mA, V <sub>DD</sub> = 1.8/2.5 V	0.9*V <sub>DD</sub>	–	–	V
I <sub>IL</sub>	Input low current	Input = V <sub>SS</sub>	–	<1	10	μA
I <sub>IH</sub>	Input high current	Input = V <sub>DD</sub>	–	<1	10	μA
I <sub>OZL</sub>	Output leakage current	Output = V <sub>SS</sub> , T <sub>j</sub> = 85°C	–	<1	5	μA
I <sub>OZH</sub>	Output leakage current	Output = V <sub>DD</sub>	–	–	50	μA
I <sub>DD</sub>	Power supply current for CY22M1L	F <sub>OUT</sub> = 12 MHz, no load F <sub>OUT</sub> = 12 MHz, 15 pF load F <sub>OUT</sub> = 48 MHz, no load F <sub>OUT</sub> = 48 MHz, 15 pF load	– – – –	1.0 1.2 1.6 2.8	– – – –	mA mA mA mA
	Power supply current for CY22M1S	F <sub>OUT</sub> = 12 MHz, no load F <sub>OUT</sub> = 12 MHz, 15 pF load F <sub>OUT</sub> = 48 MHz, no load F <sub>OUT</sub> = 48 MHz, 15 pF load	– – – –	1.5 3.3 2.5 6.5	– – – –	mA mA mA mA
I <sub>PD</sub>	Power down current	T <sub>j</sub> = 85°C	–	25	50	μA
R <sub>UP</sub>	Input pull-up resistors	PD#/OE = low	1	–	6	MΩ
		PD#/OE = high	100	–	250	kΩ
R <sub>DN</sub>	Output pull-down resistors	–	500	–	1500	kΩ
C <sub>IN</sub>	Input capacitance of PD#/OE pin	–	–	–	7	pF

**Notes**

- Parameters are guaranteed by design and characterization. Not 100% tested in production.
- V<sub>IH2</sub> absolute maximum value is 2.1V. For V<sub>DD</sub> = 1.6V to 1.8 V, the maximum V<sub>IH2</sub> is V<sub>DD</sub> + 0.3V.

**AC Electrical Specifications**

Parameter <sup>[5]</sup>	Description	Test Conditions	Min	Typ	Max	Unit
F <sub>IN</sub> (Crystal)	Crystal frequency range (XIN)	–	8	–	48	MHz
F <sub>IN</sub> (Clock)	Clock frequency range (REFIN)	–	1	–	80	MHz
F <sub>CLK</sub>	Output frequency	–	1	–	80	MHz
T <sub>R</sub>	Output rise time	Measured from 20% to 80% V <sub>DD</sub> , C <sub>OUT</sub> = 15 pF, drive strength set to high	–	–	1.5	ns
T <sub>F</sub>	Output fall time	Measured from 80% to 20% V <sub>DD</sub> , C <sub>OUT</sub> = 15 pF, drive strength set to high	–	–	1.5	ns
DC	Output clock duty cycle	Using PLL as a source	45	50	55	%
T <sub>CCJ</sub>	Cycle-to-cycle jitter of CLKOUT using PLL	80 MHz ≥ F <sub>OUT</sub> ≥ 50 MHz F <sub>OUT</sub> < 50 MHz	– –	150 –	200 1	ps %T <sub>OUT</sub> <sup>[6]</sup>
T <sub>P</sub>	Period jitter of CLKOUT using PLL	80 MHz ≥ F <sub>OUT</sub> ≥ 50 MHz F <sub>OUT</sub> < 50 MHz	– –	150 –	200 1	ps %T <sub>OUT</sub> <sup>[6]</sup>
T <sub>PO,CLK</sub>	Power on time for output clock	–	–	–	5	ms
T <sub>PU,CLK</sub>	Power up time from power down for output clock	–	–	–	5	ms
T <sub>PD,ASYNC</sub>	Time from falling edge of PD# to stopped outputs, asynchronous mode	–	–	–	100	ns
T <sub>PD,SYNC</sub>	Time from falling edge of PD# to stopped outputs, synchronous mode	–	–	–	1.5T + 100	ns
T <sub>OD,ASYNC</sub>	Time from falling edge of OE to stopped outputs, asynchronous mode	–	–	–	100	ns
T <sub>OD,SYNC</sub>	Time from falling edge of OE to stopped outputs, synchronous mode	–	–	–	1.5T + 100	ns
T <sub>OE,ASYNC</sub>	Time from rising edge of OE to running outputs, asynchronous mode	–	–	–	100	ns

**Note**

5. Parameters are guaranteed by design and characterization. Not 100% tested in production.  
 6. %TOUT is the percentage of the output clock period.



### Recommended Crystal Specifications for SMD Package

Parameter	Description	Range 1	Range 2	Range 3	Unit
F <sub>MIN</sub>	Minimum frequency	8	14	28	MHz
F <sub>MAX</sub>	Maximum frequency	14	28	48	MHz
R <sub>1</sub>	Maximum motional resistance (ESR)	135	50	30	Ω
C <sub>0</sub>	Nominal shunt capacitance	4	4	2	pF
C <sub>L</sub>	Nominal load capacitance	18	14	12	pF
D <sub>L</sub>	Maximum crystal drive level	300	300	300	μW

### Switching Waveforms

Figure 3. CLKOUT Rise and Fall Time

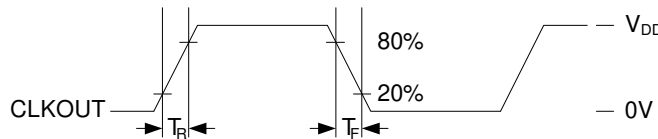

Figure 4. Duty Cycle Timing (DC)

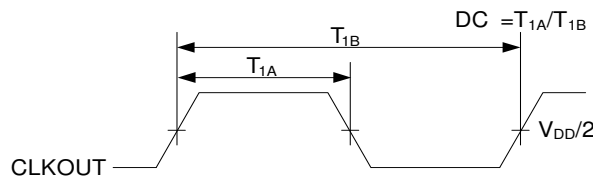

Figure 5. Period Jitter

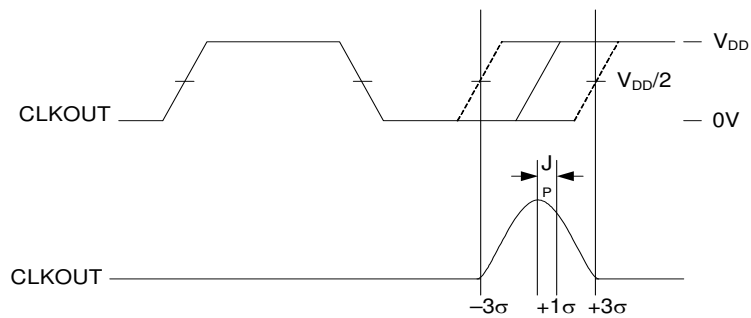

Figure 6. Cycle to Cycle Jitter

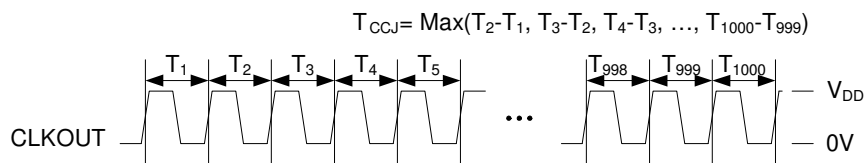

Figure 7. Power On Timing

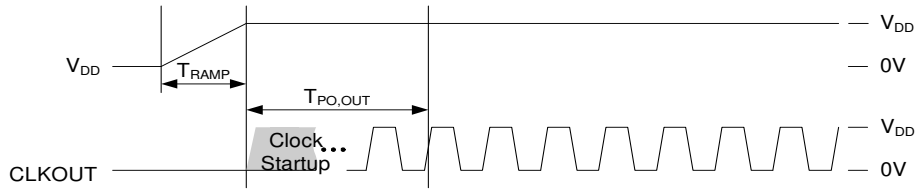

Figure 8. Power Down Timing (Synchronous and Asynchronous Modes) and Power Up Timing

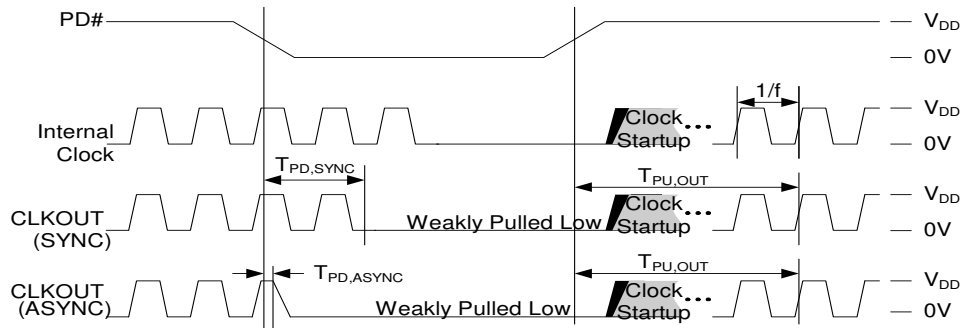
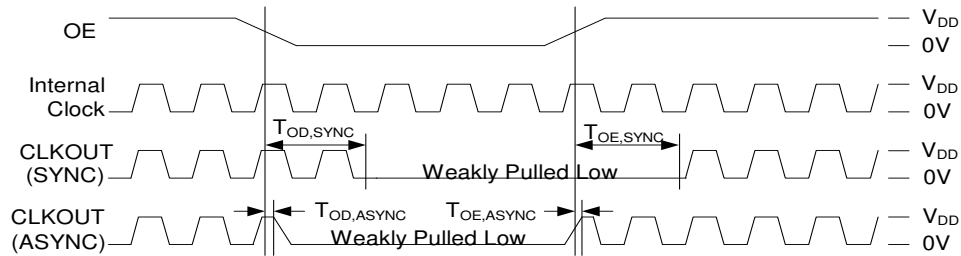

Figure 9. CLKOUT Enable (Synchronous and Asynchronous Modes) and CLKOUT Disable Timing



**Ordering Information**

Part Number	Type	V <sub>DD</sub> (V)	Production Flow
<b>Pb-free</b>			
CY22M1SCALGXC-00T	8-pin QFN, Field Programmable - Tape and Reel	Supply voltage: 2.5 V, 3.0 V, or 3.3 V	Commercial, 0 °C to 70 °C
CY22M1LCALGXC-00T	8-pin QFN, Field Programmable-Tape and Reel	Supply voltage: 1.8 V	Commercial, 0 °C to 70 °C
CY22M1SCALGXI-00T	8-pin QFN, Field Programmable-Tape and Reel	Supply voltage: 2.5 V, 3.0 V, or 3.3 V	Industrial, -40 °C to +85 °C
CY22M1LCALGXI-00T	8-pin QFN, Field Programmable - Tape and Reel	Supply voltage: 1.8 V	Industrial, -40 °C to +85 °C
<b>Programmer</b>			
CY3675-CLKMAKER1		Programming Kit	
CY3675-QFN8A		Socket Adapter Board, for programming CY22M1 and CY22U1.	

**Possible Configurations**

Some product offerings are factory programmed customer specific devices with customized part numbers. The Possible Configurations table shows the available device types, but not complete part numbers. Contact your local Cypress FAE or Sales Representative for more information.

Part Number <sup>[7, 8]</sup>	Type	V <sub>DD</sub> (V)	Production Flow
<b>Pb-free</b>			
CY22M1SCxLGXC-yyT	8-pin QFN - Tape and Reel	Supply voltage: 2.5 V, 3.0 V, or 3.3 V	Commercial, 0°C to 70°C
CY22M1LCxLGXC-yyT	8-pin QFN - Tape and Reel	Supply voltage: 1.8 V	Commercial, 0°C to 70°C
CY22M1SCxLGXI-yyT	8-pin QFN - Tape and Reel	Supply voltage: 2.5 V, 3.0 V, or 3.3 V	Industrial, -40°C to +85°C
CY22M1LCxLGXI-yyT	8-pin QFN - Tape and Reel	Supply voltage: 1.8 V	Industrial, -40°C to +85°C

**Ordering Code Definitions**

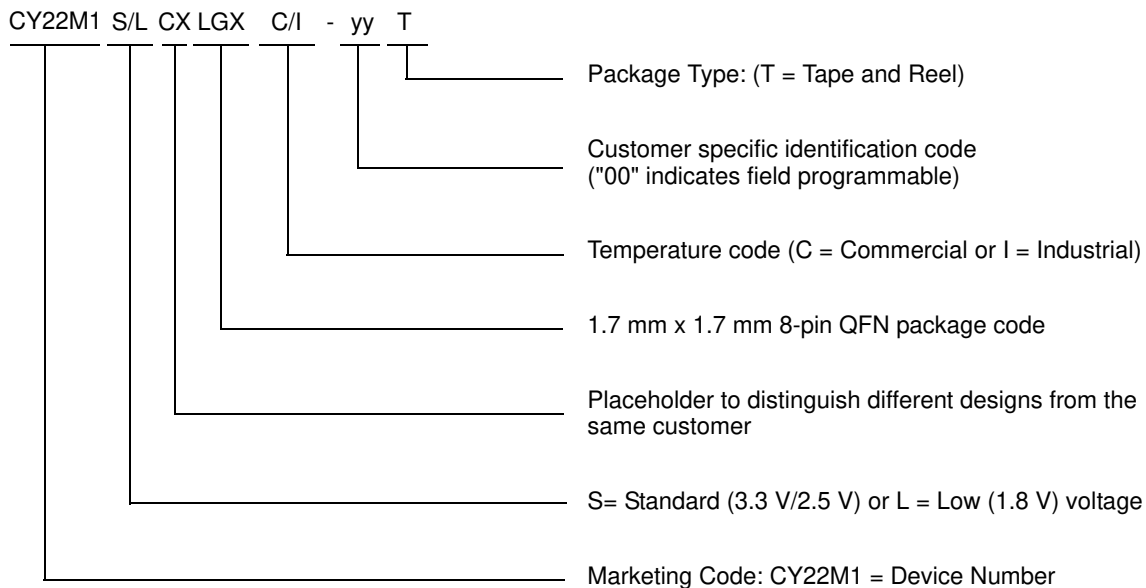

**Notes**

- 7. x indicates a part marking placeholder to distinguish different configurations for the same customer, beginning alphabetically from "A".
- 8. yy indicates "Factory Programmable" and are factory programmed configurations. For more details, contact your local Cypress FAE or Cypress Sales Representative.

Figure 10. Actual Marking

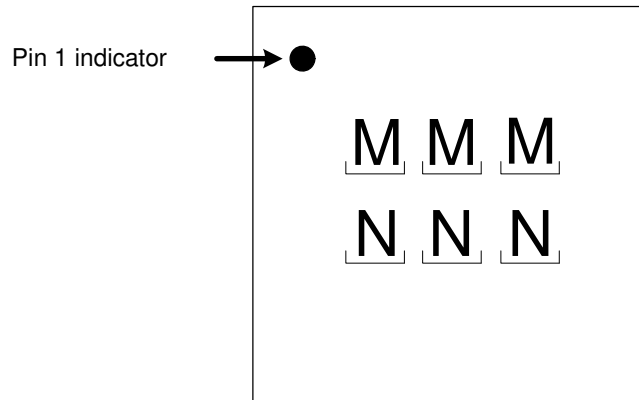

(MMM) = 7<sup>th</sup>, 8<sup>th</sup> and 9<sup>th</sup> characters of marketing part number

(NNN) = Last 3 digits of assembly lot number

### Package Drawing and Dimensions

Figure 11. Package Outline Drawing: CY22M1 8-Pin 1.7 mm x 1.7 mm x 0.6 mm QFN

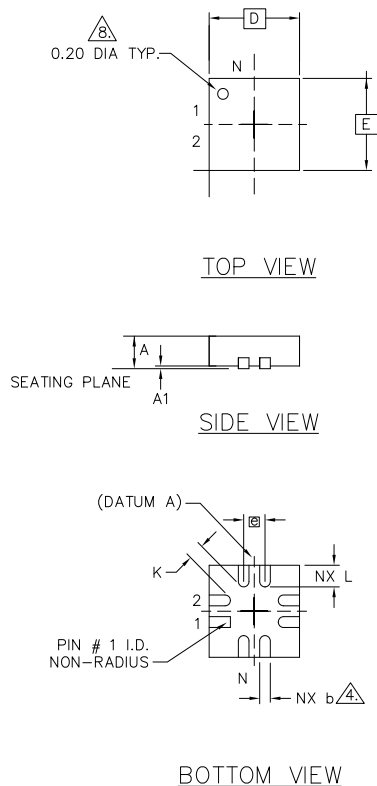

NOTES :

1. DIMENSIONING AND TOLERANCING CONFORME TO ASME Y14.5M – 1994.
2. ALL DIMENSIONS ARE IN MILLIMETERS,  $\phi$  IS IN DEGREES.
3. N IS THE TOTAL NUMBER OF TERMINALS.
4. DIMENSION b APPLIES TO METALLIZED TERMINAL AND IS MEASURED BETWEEN 0.15 AND 0.30mm FROM TERMINAL TIP. IF THE TERMINAL HAS THE OPTIONAL RADIUS ON THE OTHER END OF THE TERMINAL, THE DIMENSION b SHOULD NOT BE MEASURED IN THAT RADIUS AREA.
5. ND AND NE REFER TO THE NUMBER OF TERMINALS ON EACH D AND E SIDE RESPECTIVELY.
6. MAX. PACKAGE WARPAGE IS 0.05 mm.
7. MAXIMUM ALLOWABLE BURRS IS 0.076 mm IN ALL DIRECTIONS.
8. PIN #1 ID ON TOP WILL BE LASER MARKED.

Symbol	COMMON DIMENSIONS			N <sub>D</sub> , N <sub>E</sub>
	MIN.	NOM.	MAX.	
A	0.50	0.55	0.60	
A1	0.00	0.02	0.05	
$\phi$	0	—	12	2
K	0.20 MIN.			
D	1.7 BSC			
E	1.7 BSC			
$\square$	0.40 BSC			
N	8			3
ND	2			5
NE	2			5
L	0.35	0.40	0.45	
b	0.15	0.20	0.25	4

REFERENCE JEDEC#: MO-220  
 PACKAGE WEIGHT: ~ 0.025gr

001-49591 \*A

**Acronyms**

Acronym	Description
DL	drive level
DNU	do not use
DUT	device under test
EMI	electromagnetic interference
ESD	electrostatic discharge
FAE	field application engineer
FS	frequency select
JEDEC EIA	joint electron devices engineering council electronic industries alliance
LVC MOS	low voltage complementary metal oxide semiconductor
OE	output enable
OSC	oscillator
PD	power down
PLL	phase-locked loop
PPM	parts per million
SS	spread spectrum
SSC	spread spectrum clock
SSON	spread spectrum on

**Document Conventions**

**Units of Measure**

Symbol	Unit of Measure
%	percent
° C	degree Celsius
KΩ	kiloohm
mA	milliampere
MHZ	megahertz
ms	millisecond
MΩ	megaohm
ns	nanosecond
pF	picofarad
ps	picosecond
uA	microampere
uw	microwatt
V	volt
Ω	ohm

**Document History Page**

Document Title: MoBL® UniClock CY22M1 Single Output, Low Power Programmable Clock Generator for Portable Applications Document Number: 001-49075				
Rev	ECN	Orig. of Change	Submission Date	Description of Change
**	2571065	DPF/CXQ/AESA	09/23/08	New Data Sheet
*A	2636981	CXQ/PYRS	01/15/09	Changed max output frequency to 80 MHz Changed min input reference frequency to 1 MHz Changed max input reference frequency to 80 MHz Changed Idd max conditions and specs Updated VIH/VIL specs for REFIN Added typical I <sub>PD</sub> value of 25uA Added period jitter spec Removed maximum frequency from Output Drive Strength table Updated part numbers in Ordering Information Replaced CyberClocksOnline and CY3672 programmer kit reference with CyClockMaker and CyClockDesigner reference Added marking format information Updated package drawing to spec 001-49591
*B	2673516	CXQ/PYRS	03/13/09	Changed from Advanced to Preliminary datasheet Deleted "1.8 V" when referring to external reference Updated V <sub>IH2</sub> maximum for CY22M1L and added note 4 Added IDD values to DC Electrical Specifications table
*C	2756169	TSAI	08/20/09	Post to external web
*D	2898568	CXQ	06/02/10	Removed non Tape and Reel parts. Moved 'yy' parts to Possible Configurations table. Updated package diagram. Updated template.
*E	3400416	PURU	10/12/2011	Updated template. Added <a href="#">Contents</a> Removed Preliminary status of datasheet Updated hyper links in <a href="#">Programming Support</a> Updated Footnotes. Added <a href="#">Units of Measure</a> .

## Sales, Solutions, and Legal Information

### Worldwide Sales and Design Support

Cypress maintains a worldwide network of offices, solution centers, manufacturer’s representatives, and distributors. To find the office closest to you, visit us at [Cypress Locations](#).

### Products

Automotive	<a href="http://cypress.com/go/automotive">cypress.com/go/automotive</a>
Clocks & Buffers	<a href="http://cypress.com/go/clocks">cypress.com/go/clocks</a>
Interface	<a href="http://cypress.com/go/interface">cypress.com/go/interface</a>
Lighting & Power Control	<a href="http://cypress.com/go/powerpsoc">cypress.com/go/powerpsoc</a> <a href="http://cypress.com/go/plc">cypress.com/go/plc</a>
Memory	<a href="http://cypress.com/go/memory">cypress.com/go/memory</a>
Optical & Image Sensing	<a href="http://cypress.com/go/image">cypress.com/go/image</a>
PSoC	<a href="http://cypress.com/go/psoc">cypress.com/go/psoc</a>
Touch Sensing	<a href="http://cypress.com/go/touch">cypress.com/go/touch</a>
USB Controllers	<a href="http://cypress.com/go/USB">cypress.com/go/USB</a>
Wireless/RF	<a href="http://cypress.com/go/wireless">cypress.com/go/wireless</a>

### PSoC® Solutions

[psoc.cypress.com/solutions](http://psoc.cypress.com/solutions)  
PSoC 1 | PSoC 3 | PSoC 5

---

© Cypress Semiconductor Corporation, 2008-2011. The information contained herein is subject to change without notice. Cypress Semiconductor Corporation assumes no responsibility for the use of any circuitry other than circuitry embodied in a Cypress product. Nor does it convey or imply any license under patent or other rights. Cypress products are not warranted nor intended to be used for medical, life support, life saving, critical control or safety applications, unless pursuant to an express written agreement with Cypress. Furthermore, Cypress does not authorize its products for use as critical components in life-support systems where a malfunction or failure may reasonably be expected to result in significant injury to the user. The inclusion of Cypress products in life-support systems application implies that the manufacturer assumes all risk of such use and in doing so indemnifies Cypress against all charges.

Any Source Code (software and/or firmware) is owned by Cypress Semiconductor Corporation (Cypress) and is protected by and subject to worldwide patent protection (United States and foreign), United States copyright laws and international treaty provisions. Cypress hereby grants to licensee a personal, non-exclusive, non-transferable license to copy, use, modify, create derivative works of, and compile the Cypress Source Code and derivative works for the sole purpose of creating custom software and or firmware in support of licensee product to be used only in conjunction with a Cypress integrated circuit as specified in the applicable agreement. Any reproduction, modification, translation, compilation, or representation of this Source Code except as specified above is prohibited without the express written permission of Cypress.

Disclaimer: CYPRESS MAKES NO WARRANTY OF ANY KIND, EXPRESS OR IMPLIED, WITH REGARD TO THIS MATERIAL, INCLUDING, BUT NOT LIMITED TO, THE IMPLIED WARRANTIES OF MERCHANTABILITY AND FITNESS FOR A PARTICULAR PURPOSE. Cypress reserves the right to make changes without further notice to the materials described herein. Cypress does not assume any liability arising out of the application or use of any product or circuit described herein. Cypress does not authorize its products for use as critical components in life-support systems where a malfunction or failure may reasonably be expected to result in significant injury to the user. The inclusion of Cypress’ product in a life-support systems application implies that the manufacturer assumes all risk of such use and in doing so indemnifies Cypress against all charges.

Use may be limited by and subject to the applicable Cypress software license agreement.