

## QW/QC030-Series Power Modules: dc-dc Converters; 18 Vdc to 36 Vdc or 36 Vdc to 75 Vdc Inputs



The QW/QC030-Series Power Modules use advanced, surface-mount technology and deliver high-quality, efficient, and compact dc-dc conversion.

### Applications

- Distributed power architectures
- Workstations
- Computer equipment
- Communications equipment
- Optical transport equipment

### Options

- Heat sinks available for extended operation
- Choice of remote on/off logic configurations
- Choice of two pin lengths

### Description

The QC/QW030-Series Power Modules are dc-dc converters that operate over an input voltage range of 18 Vdc to 36 Vdc or 36 Vdc to 75 Vdc and provide a precisely regulated dc output. The outputs are fully isolated from the inputs, allowing versatile polarity configurations and grounding connections. The modules have maximum power ratings of 30 W at a typical full-load efficiency of up to 86%.

These encapsulated modules offer a metal case for optimum thermal performance. Threaded-through holes are provided to allow easy mounting or addition of a heat sink for high-temperature applications. The standard feature set includes remote sensing, output trim, and remote on/off for convenient flexibility in distributed power applications.

### Features

- Small size: 36.8 mm x 57.9 mm x 12.7 mm (1.45 in. x 2.28 in. x 0.50 in.)
- High power density
- High efficiency: 86% typical
- Low output noise
- Constant frequency
- Industry-standard pinout
- Metal case
- 2:1 input voltage range
- Overvoltage and overcurrent protection
- Remote on/off
- Remote sense
- Adjustable output voltage
- ISO\* 9001 and ISO14001 Certified manufacturing facilities
- UL† 60950 Recognized, CSA‡ C22.2 No. 60950-00 Certified, VDE§ 0805 (EN60950-1) Licensed (For QW030 only)
- CE mark meets 73/23/EEC and 93/68/EEC directives\*\* (For QW030 only)

\* ISO is a registered trademark of the International Organization for Standardization.

† UL is a registered trademark of Underwriters Laboratories, Inc.

‡ CSA is a registered trademark of Canadian Standards Assn.

§ VDE is a trademark of Verband Deutscher Elektrotechniker e.V.

\*\*This product is intended for integration into end-use equipment. All the required procedures for CE marking of end-use equipment should be followed. (The CE mark is placed on selected products.)

## Absolute Maximum Ratings

Stresses in excess of the absolute maximum ratings can cause permanent damage to the device. These are absolute stress ratings only. Functional operation of the device is not implied at these or any other conditions in excess of those given in the operations sections of the data sheet. Exposure to absolute maximum ratings for extended periods can adversely affect device reliability.

Parameter	Device	Symbol	Min	Max	Unit
Input Voltage:					
Continuous	QC030x	$V_I$	—	50	Vdc
	QW030x	$V_I$	—	80	Vdc
Transient (100 ms)	QW030x	$V_{I, trans}$	—	100	V
Operating Case Temperature (See Thermal Considerations section.)	All	$T_c$	-40	105*	°C
Storage Temperature	All	$T_{stg}$	-55	125	°C
I/O Isolation Voltage	All	—	—	1500	Vdc

\* Maximum case temperature varies based on power dissipation. See power derating curves for details.

## Electrical Specifications

Unless otherwise indicated, specifications apply over all operating input voltage, resistive load, and temperature conditions.

**Table 1. Input Specifications**

Parameter	Device	Symbol	Min	Typ	Max	Unit
Operating Input Voltage:						
QC030x	All	$V_I$	18	24	36	Vdc
QW030x	All	$V_I$	36	48	75	Vdc
Maximum Input Current ( $V_I = 0$ V to 75 V; $I_O = I_{O, max}$ ):						
QC030x	All	$I_I$	—	—	3.5	A
QW030x	All	$I_I$	—	—	2.2	A
Inrush Transient	All	$i^2t$	—	—	0.2	A <sup>2</sup> s
Input Reflected-ripple Current, Peak-to-peak (5 Hz to 20 MHz, 12 $\mu$ H source impedance; see Test Configurations section.)	All		—	5	—	mAp-p
Input Ripple Rejection (120 Hz)	All	—	—	50	—	dB

## Fusing Considerations

**CAUTION: This power module is not internally fused. An input line fuse must always be used.**

This encapsulated power module can be used in a wide variety of applications, ranging from simple stand-alone operation to an integrated part of a sophisticated power architecture. To preserve maximum flexibility, internal fusing is not included; however, to achieve maximum safety and system protection, always use an input line fuse. The safety agencies require a normal-blow fuse with a maximum rating of 5 A (for QW030) and 10 A (for QC030) (see Safety Considerations section). Based on the information provided in this data sheet on inrush energy and maximum dc input current, the same type of fuse with a lower rating can be used. Refer to the fuse manufacturer's data for further information.

**Electrical Specifications** (continued)

**Table 2. Output Specifications**

Parameter	Device Suffix	Symbol	Min	Typ	Max	Unit
Output Voltage Set Point ( $V_i = 48\text{ V}$ ; $I_o = I_{o, \text{max}}$ ; $T_c = 25\text{ }^\circ\text{C}$ )	F	$V_{O, \text{set}}$	3.23	3.3	3.37	Vdc
	A	$V_{O, \text{set}}$	4.92	5.0	5.12	Vdc
	B	$V_{O, \text{set}}$	11.80	12.0	12.30	Vdc
	C	$V_{O, \text{set}}$	14.55	15.0	15.48	Vdc
Output Voltage (Over all operating input voltage, resistive load, and temperature conditions until end of life. See Test Configurations section.)	F	$V_o$	3.18	3.3	3.42	Vdc
	A	$V_o$	4.86	5.0	5.18	Vdc
	B	$V_o$	11.60	12.0	12.45	Vdc
	C	$V_o$	14.25	15.0	15.75	Vdc
Output Regulation: Line ( $V_i = 36\text{ V to }75\text{ V}$ )  Load ( $I_o = I_{o, \text{min}} \text{ to } I_{o, \text{max}}$ )  Temperature ( $T_c = -30\text{ }^\circ\text{C to }+100\text{ }^\circ\text{C}$ )	A, F	—	—	1	—	mV
	B, C	—	—	2	—	mV
	A, F	—	—	2	—	mV
	B	—	—	8	—	mV
	C	—	—	10	—	mV
	A, F	—	—	15	—	mV
	B	—	—	40	—	mV
	C	—	—	65	—	mV
Output Ripple and Noise Voltage (See Test Configurations section.): Measured across one $4.7\text{ }\mu\text{F}$ ceramic capacitor: RMS  Peak-to-peak (5 Hz to 20 MHz)  Measured across one $2.2\text{ }\mu\text{F}$ ceramic capacitor: RMS Peak-to-peak (5 Hz to 20 MHz)	F	—	—	15	—	mVrms
	A	—	—	10	—	mVrms
	F	—	—	40	—	mVp-p
	A	—	—	30	—	mVp-p
	B, C	—	—	15	—	mVrms
	B	—	—	40	—	mVp-p
	C	—	—	50	—	mVp-p
	External Load Capacitance	A, F B, C	— —	0 0	— —	1000 470
Output Current (At $I_o < I_{o, \text{min}}$ , the modules may exceed output ripple specifications.)	F	$I_o$	0.45	—	6.50	A
	A	$I_o$	0.30	—	6.00	A
	B	$I_o$	0.26	—	3.00	A
	C	$I_o$	0.26	—	2.66	A
Output Current-limit Inception ( $V_o = 90\%$ of $V_{O, \text{set}}$ )	F	$I_o$	—	7.5	—	A
	A	$I_o$	—	7.0	—	A
	B	$I_o$	—	3.7	—	A
	C	$I_o$	—	3.3	—	A
Output Short-circuit Current ( $V_o = 0.25\text{ V}$ )	F	$I_o$	—	11.5	—	A
	A	$I_o$	—	9.5	—	A
	B	$I_o$	—	5.5	—	A
	C	$I_o$	—	4.5	—	A

**Electrical Specifications** (continued)

**Table 2. Output Specifications** (continued)

Parameter	Device Suffix	Symbol	Min	Typ	Max	Unit
Efficiency ( $V_I = 48\text{ V}$ ; $I_O = I_{O, \text{max}}$ ): $T_A = 25\text{ }^\circ\text{C}$	F	$\eta$	—	83	—	%
	A	$\eta$	—	86	—	%
	B, C	$\eta$	—	89	—	%
Switching Frequency	All	—	—	300	—	kHz
Dynamic Response ( $\dot{I}_O/\dot{I}_T = 1\text{ A}/10\text{ }\mu\text{s}$ , $V_I = 48\text{ V}$ , $T_C = 25\text{ }^\circ\text{C}$ ):						
Load Change from $I_O = 50\%$ to $75\%$ of $I_{O, \text{max}}$ :						
Peak Deviation	A, C, F	—	—	2.0	—	% $V_{O, \text{set}}$
	B	—	—	2.5	—	% $V_{O, \text{set}}$
Settling Time ( $V_O < 10\%$ of peak deviation)	B, C, F	—	—	5.0	—	ms
	A	—	—	3.0	—	ms
Load Change from $I_O = 50\%$ to $25\%$ of $I_{O, \text{max}}$ :						
Peak Deviation	A, C, F	—	—	2.0	—	% $V_{O, \text{set}}$
	B	—	—	2.5	—	% $V_{O, \text{set}}$
Settling Time ( $V_O < 10\%$ of peak deviation)	B, C, F	—	—	5.0	—	ms
	A	—	—	3.0	—	ms

\* Engineering estimate.

**Table 3. Isolation Specifications**

Parameter	Device	Min	Typ	Max	Unit
Isolation Capacitance (engineering estimate)	All	—	600	—	pF
Isolation Resistance	All	10	—	—	M $\Omega$

**Table 4. General Specifications**

Parameter	Device	Min	Typ	Max	Unit
Calculated MTBF ( $I_O = 80\%$ of $I_{O, \text{max}}$ ; $T_A = 40\text{ }^\circ\text{C}$ )	All	5,000,000			hours
Weight	All	—	—	75 (2.7)	g (oz.)

## Feature Specifications

Unless otherwise indicated, specifications apply over all operating input voltage, resistive load, and temperature conditions. See Feature Descriptions section of this data sheet for additional information.

Parameter	Device Suffix	Symbol	Min	Typ	Max	Unit
<p>Remote On/Off Signal Interface (<math>V_I = V_{I, \min}</math> to <math>V_{I, \max}</math>; open collector or equivalent compatible; signal referenced to <math>V_I(-)</math> terminal.): Negative Logic: Device Code Suffix "1": Logic Low—Module On Logic High—Module Off Positive Logic: If Device Code Suffix "1" Is Not Specified: Logic Low—Module Off Logic High—Module On Module Specifications: On/Off Current—Logic Low On/Off Voltage: Logic Low Logic High (<math>I_{on/off} = 0</math> mA) Open Collector Switch Specifications: Leakage Current During Logic High (<math>V_{on/off} = 15</math> V) Output Low Voltage During Logic Low (<math>I_{on/off} = 1</math> mA)</p>	All	$I_{on/off}$	—	—	1.0	mA
	All	$V_{on/off}$	-0.7	—	1.2	V
	All	$V_{on/off}$	—	—	15	V
	All	$I_{on/off}$	—	—	50	$\mu$ A
	All	$V_{on/off}$	—	—	1.2	V
<p>Turn-on Delay and Rise Times (at 80% of <math>I_{O, \max}</math>; <math>T_A = 25</math> °C): Case 1: On/Off Input Is Set for Logic High and then Input Power Is Applied (delay from point at which <math>V_I = V_{I, \min}</math> until <math>V_O = 10\%</math> of <math>V_{O, \text{nom}}</math>). Case 2: Input Power Is Applied for at Least One Second, and Then the On/Off Input Is Set to Logic High (delay from point at which <math>V_{on/off} = 0.9</math> V until <math>V_O = 10\%</math> of <math>V_{O, \text{nom}}</math>). Output Voltage Rise Time (time for <math>V_O</math> to rise from 10% of <math>V_{O, \text{nom}}</math> to 90% of <math>V_{O, \text{nom}}</math>) Output Voltage Overshoot (at 80% of <math>I_{O, \max}</math>; <math>T_A = 25</math> °C)</p>	All	$T_{\text{delay}}$	—	8	—	ms
	All	$T_{\text{delay}}$	—	1	—	ms
	All	$T_{\text{rise}}$	—	1	—	ms
	All	—	—	—	5	%
<p>Output Voltage Adjustment (See Feature Descriptions section.): Output Voltage Remote-sense Range Output Voltage Set-point Adjustment Range (trim)</p>	All	—	—	—	0.5	V
	A, F	—	95	—	110	% $V_{O, \text{nom}}$
	B, C	—	90	—	110	% $V_{O, \text{nom}}$
Output Overvoltage Protection (clamp)	F	$V_{O, \text{ovp}}$	3.8	—	4.9	V
	A	$V_{O, \text{ovp}}$	5.5	—	7.0	V
	B	$V_{O, \text{ovp}}$	13.2	—	21.0	V
	C	$V_{O, \text{ovp}}$	16.5	—	24.0	V

**Feature Specifications** (continued)

Parameter	Device Suffix	Symbol	Min	Typ	Max	Unit
Overtemperature Protection ( $V_I = 75$ V, see Figure 8.):						
$I_O = 6.5$ A	F	$T_{case}$	—	105	—	°C
$I_O = 6$ A	A	$T_{case}$	—	105	—	°C
$I_O = 3$ A	B	$T_{case}$	—	105	—	°C
$I_O = 2.66$ A	C	$T_{case}$	—	105	—	°C
Undervoltage Lockout:						
QC030x	All	—	—	14	—	V
QW030x	All	—	—	27	—	V

**Test Configurations**

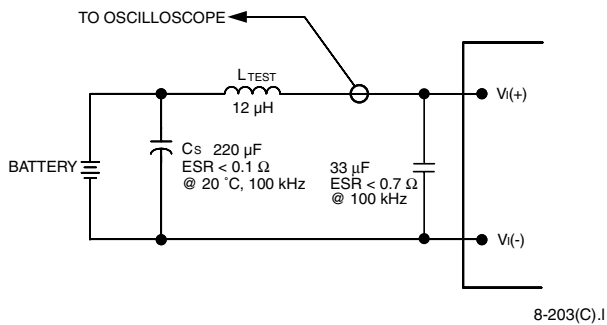

Note: Measure input reflected-ripple current with a simulated source inductance ( $L_{TEST}$ ) of 12 µH. Capacitor  $C_S$  offsets possible battery impedance. Measure current as shown above.

**Figure 1. QC/QW030-Series Input Reflected-Ripple Test Setup**

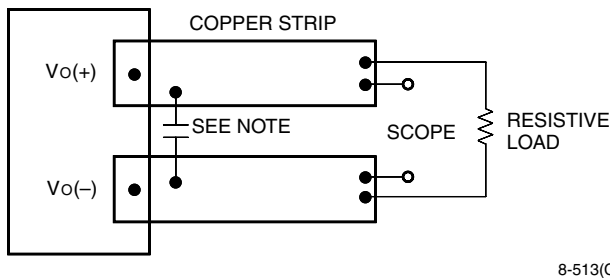

Note: Use the capacitor(s) referenced in the Output Ripple and Noise Voltage specifications in the Output Specifications table. Scope measurement should be made using a BNC socket. Position the load between 51 mm and 76 mm (2 in. and 3 in.) from the module.

**Figure 2. QC/QW030-Series Peak-to-Peak Output Noise Measurement Test Setup**

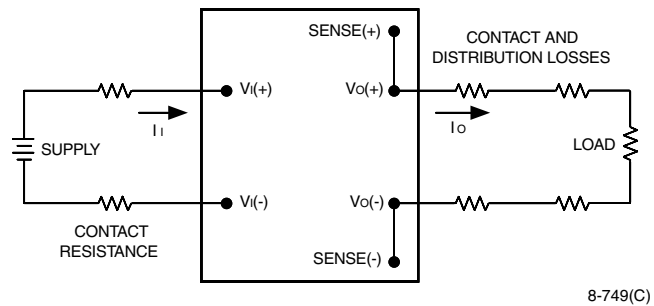

Note: All measurements are taken at the module terminals. When socketing, place Kelvin connections at module terminals to avoid measurement errors due to socket contact resistance.

$$\eta = \left( \frac{[V_O(+)-V_O(-)]I_O}{[V_I(+)-V_I(-)]I_I} \right) \times 100 \%$$

**Figure 3. QC/QW030-Series Output Voltage and Efficiency Measurement Test Setup**

**Design Considerations**

**Grounding Considerations**

For the QC modules, the case is internally connected to the  $V_I(-)$  pin. For the QW modules, the case is internally connected to the  $V_I(+)$  pin.

## Design Considerations (continued)

### Input Source Impedance

The power module should be connected to a low ac-impedance input source. Highly inductive source impedances can affect the stability of the power module. If the input source inductance exceeds  $4\ \mu\text{H}$ , a  $33\ \mu\text{F}$  electrolytic capacitor ( $\text{ESR} < 0.7\ \Omega$  at  $100\ \text{kHz}$ ) mounted close to the power module helps ensure stability of the unit.

## Safety Considerations

### QW Modules

For safety-agency approval of the system in which the power module is used, the power module must be installed in compliance with the spacing and separation requirements of the end-use safety agency standard, i.e., *UL60950*, *CSA C22.2 No. 60950-00*, and *VDE 0805 (EN60950-1)*.

If the input source is non-SELV (ELV or a hazardous voltage greater than 60 Vdc and less than or equal to 75 Vdc), for the module's output to be considered meeting the requirements of safety extra-low voltage (SELV), all of the following must be true:

- The input source is to be provided with reinforced insulation from any hazardous voltages, including the ac mains.
- One  $V_I$  pin and one  $V_O$  pin are to be grounded, or both the input and output pins are to be kept floating.
- The input pins of the module are not operator accessible.
- Another SELV reliability test is conducted on the whole system, as required by the safety agencies, on the combination of supply source and the subject module to verify that under a single fault, hazardous voltages do not appear at the module's output.

**Note:** Do not ground either of the input pins of the module without grounding one of the output pins. This may allow a non-SELV voltage to appear between the output pin and ground.

The power module has extra-low voltage (ELV) outputs when all inputs are ELV.

The input to the QW030 is to be provided with a maximum 5 A normal-blow fuse in the ungrounded lead.

The input to the QC030 is to be provided with a maximum 10 A normal-blow fuse in the ungrounded lead.

## Feature Descriptions

### Overcurrent Protection

To provide protection in a fault (output overload) condition, the unit is equipped with internal current-limiting circuitry and can endure current limiting for an unlimited duration. At the point of current-limit inception, the unit shifts from voltage control to current control. If the output voltage is pulled very low during a severe fault, the current-limit circuit can exhibit either foldback or tailout characteristics (output-current decrease or increase). The unit operates normally once the output current is brought back into its specified range.

### Remote On/Off

Two remote on/off options are available. Positive logic remote on/off turns the module on during a logic-high voltage on the remote ON/OFF pin, and off during a logic low. Negative logic remote on/off, device code suffix "1," turns the module off during logic-high voltage and on during a logic low.

To turn the power module on and off, the user must supply a switch to control the voltage between the on/off terminal and the  $V_I(-)$  terminal ( $V_{\text{on/off}}$ ). The switch may be an open collector or equivalent (see Figure 4). A logic low is  $V_{\text{on/off}} = -0.7\ \text{V}$  to  $1.2\ \text{V}$ . The maximum  $I_{\text{on/off}}$  during a logic low is 1 mA. The switch should maintain a logic-low voltage while sinking 1 mA.

During a logic high, the maximum  $V_{\text{on/off}}$  generated by the power module is 15V. The maximum allowable leakage current of the switch at  $V_{\text{on/off}} = 15\ \text{V}$  is  $50\ \mu\text{A}$ .

If not using the remote on/off feature, do one of the following:

For positive logic, leave the ON/OFF pin open.

For negative logic, short the ON/OFF pin to  $V_I(-)$ .

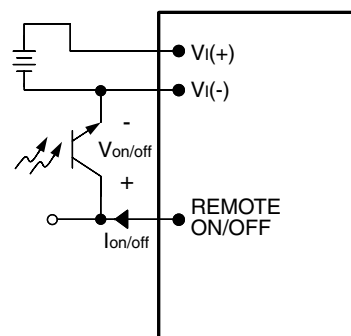

8-758(C).a

Figure 4. QC/QW030-Series Remote On/Off Implementation

**Feature Descriptions** (continued)

**Remote Sense**

Remote sense minimizes the effects of distribution losses by regulating the voltage at the remote-sense connections. The voltage between the remote-sense pins and the output terminals must not exceed the output voltage sense range given in the Feature Specifications table, e.g., on the QW030A:

$$[V_{O(+)} - V_{O(-)}] - [SENSE(+)-SENSE(-)] \leq 0.5 V$$

The voltage between the  $V_{O(+)}$  and  $V_{O(-)}$  terminals must not exceed the minimum output overvoltage protection value shown in the Feature Specifications table. This limit includes any increase in voltage due to remote-sense compensation and output voltage set-point adjustment (trim). See Figure 5.

If not using the remote-sense feature to regulate the output at the point of load, then connect SENSE(+) to  $V_{O(+)}$  and SENSE(-) to  $V_{O(-)}$  at the module.

Although the output voltage can be increased by both the remote sense and by the trim, the maximum increase for the output voltage is not the sum of both. The maximum increase is the larger of either the remote sense or the trim. Consult your Tyco Electronics' Account Manager or Application Engineer if you need to increase the output voltage more than the above limitation.

The amount of power delivered by the module is defined as the voltage at the output terminals multiplied by the output current. When using remote sense and trim, the output voltage of the module can be increased, which at the same output current would increase the power output of the module. Care should be taken to ensure that the maximum output power of the module remains at or below the maximum rated power.

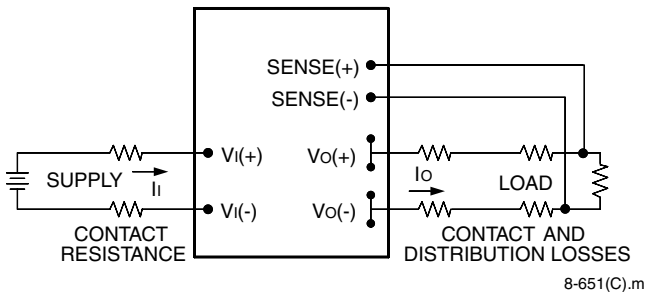

**Figure 5. QC/QW030-Series Effective Circuit Configuration for Single-Module Remote-Sense Operation**

**Output Voltage Set-Point Adjustment (Trim)**

Output voltage trim allows the user to increase or decrease the output voltage set point of a module. This is accomplished by connecting an external resistor between the TRIM pin and either the SENSE(+) or SENSE(-) pins. The trim resistor should be positioned close to the module.

If not using the trim feature, leave the TRIM pin open.

With an external resistor between the TRIM and SENSE(+) pins ( $R_{adj-down}$ ), the output voltage set point ( $V_{O, adj}$ ) decreases (see Figure 6). The following equation determines the required external-resistor value to obtain a change in output voltage from  $V_{O, nom}$  to  $V_{O, adj}$ . The values of G, H, and L are shown in Table 5.

$$R_{adj-down} = \left[ \frac{(V_{O, adj} - L)G}{(V_{O, nom} - V_{O, adj})} - H \right] \Omega$$

The QC/QW030 modules have a fixed current-limit set point. As the output voltage is adjusted down, the available output power is reduced.

With an external resistor connected between the TRIM and SENSE(-) pins ( $R_{adj-up}$ ), the output voltage set point ( $V_{O, adj}$ ) increases (see Figure 7).

The following equation determines the required external-resistor value to obtain a change in output voltage from  $V_{O, nom}$  to  $V_{O, adj}$ . The values of G, H, K, and L are shown in Table 5.

$$R_{adj-up} = \left( \left[ \frac{GL}{[(V_{O, adj} - L) - K]} \right] - H \right) \Omega$$

**Table 5. Values for Trim Equations**

Device Suffix	$V_{O, nom}$	G	H	K	L
F	3.3	5110	3010	2.06	1.24
A	5	5110	3010	2.5	2.5
B	12	10,000	3010	9.5	2.5
C	15	10,000	3010	12.5	2.5

The voltage between the  $V_{O(+)}$  and  $V_{O(-)}$  terminals must not exceed the minimum output overvoltage protection value shown in the Feature Specifications table. This limit includes any increase in voltage due to remote-sense compensation and output voltage set-point adjustment (trim). See Figure 5.



## Feature Descriptions (continued)

### Output Voltage Set-Point Adjustment (Trim) (continued)

Although the output voltage can be increased by both the remote sense and by the trim, the maximum increase for the output voltage is not the sum of both. The maximum increase is the larger of either the remote sense or the trim. Consult your Tyco Electronics' Account Manager or Application Engineer if the output voltage needs to be increased more than the above limitation.

The amount of power delivered by the module is defined as the voltage at the output terminals multiplied by the output current. When using remote sense and trim, the output voltage of the module can be increased, which at the same output current would increase the power output of the module. Care should be taken to ensure that the maximum output power of the module remains at or below the maximum rated power.

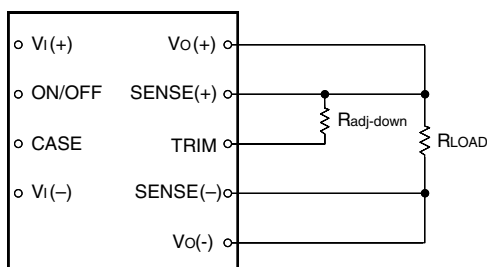

8-715(C).i

**Figure 6. QC/QW030-Series Circuit Configuration to Decrease Output Voltage**

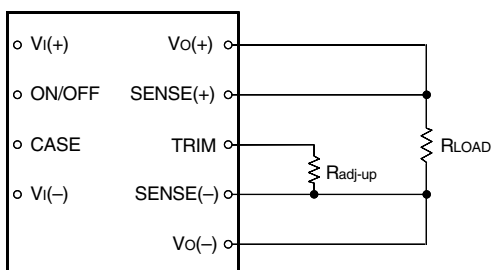

8-748(C).f

**Figure 7. QC/QW030-Series Circuit Configuration to Increase Output Voltage**

## Output Overvoltage Protection

The output overvoltage clamp consists of control circuitry, independent of the primary regulation loop, that monitors the voltage on the output terminals. This control loop has a higher voltage set point than the primary loop (see the Feature Specifications table). In a fault condition, the overvoltage clamp ensures that the output voltage does not exceed  $V_{O, \text{clamp, max}}$ . This provides a redundant voltage-control that reduces the risk of output overvoltage.

## Overtemperature Protection

These modules feature overtemperature protection to safeguard the modules against thermal damage.

When the temperature exceeds the overtemperature threshold given in the feature specifications table, the module will limit the available output current in order to help protect against thermal damage. The overcurrent inception point will gradually move back to its original level as the module is cooled below the overtemperature threshold.

## Input Undervoltage Lockout

At input voltages below the input undervoltage lockout limit, the module operation is disabled. The module will begin to operate at an input voltage between the undervoltage lockout limit and the minimum operating input voltage.

## Thermal Considerations

### Introduction

The power modules operate in a variety of thermal environments; however, sufficient cooling should be provided to help ensure reliable operation of the unit. Heat-dissipating components inside the unit are thermally coupled to the case. Heat is removed by conduction, convection, and radiation to the surrounding environment. Proper cooling can be verified by measuring the case temperature. The case temperature should be measured at the position indicated in Figure 8.

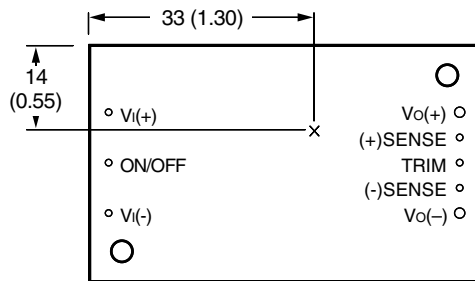

8-2104(C).a

Note: Top view, pin locations are for reference only.  
Measurements shown in millimeters and (inches).

**Figure 8. QC/QW030-Series Case Temperature Measurement Location**

The temperature at this location should not exceed 105 °C. The output power of the module should not exceed the rated power for the module as listed in the Ordering Information table.

Although the maximum case temperature of the power modules is 105 °C, you can limit this temperature to a lower value for extremely high reliability.

## Heat Transfer Without Heat Sinks

Increasing airflow over the module enhances the heat transfer via convection. Figures 9 and 10 show the maximum power that can be dissipated by the module without exceeding the maximum case temperature versus local ambient temperature ( $T_A$ ) for natural convection through 3 m/s (600 ft./min.).

Systems in which these power modules may be used typically generate natural convection airflow rates of 0.3  $\text{ms}^{-1}$  (60 ft./min.) due to other heat-dissipating components in the system. Therefore, the natural convection condition represents airflow rates of up to 0.3  $\text{ms}^{-1}$  (60 ft./min.). Use of Figure 9 is shown in the following example.

### Example

What is the minimum airflow necessary for a QW030A operating at  $V_I = 48$  V, an output current of 3.5 A, and a maximum ambient temperature of 89 °C?

### Solution

Given:  $V_I = 48$  V  
 $I_O = 3.5$  A  
 $T_A = 89$  °C

Determine  $P_D$  (Use Figure 12.):

$$P_D = 3 \text{ W}$$

Determine airflow ( $v$ ) (Use Figure 9.):

$$v = 1.0 \text{ m/s (200 ft./min.)}$$

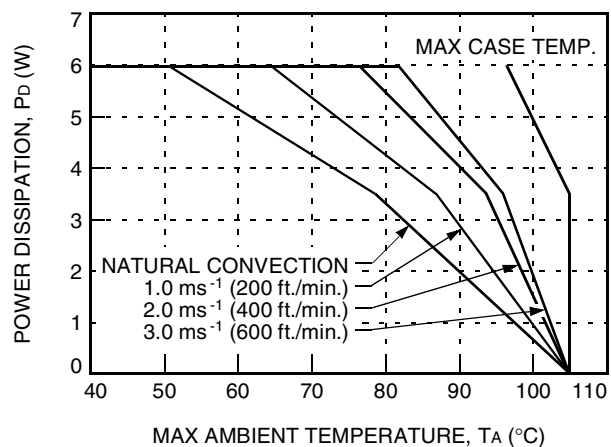

8-3406(F)

**Figure 9. QW030A, F Forced Convection Power Derating with No Heat Sink; Either Orientation**

**Thermal Considerations** (continued)

**Heat Transfer Without Heat Sinks** (continued)

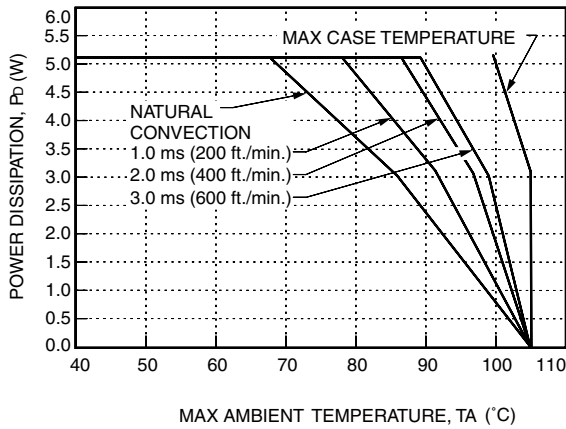

8-3366(C).a

**Figure 10. QW030B, C Forced Convection Power Derating with No Heat Sink; Either Orientation**

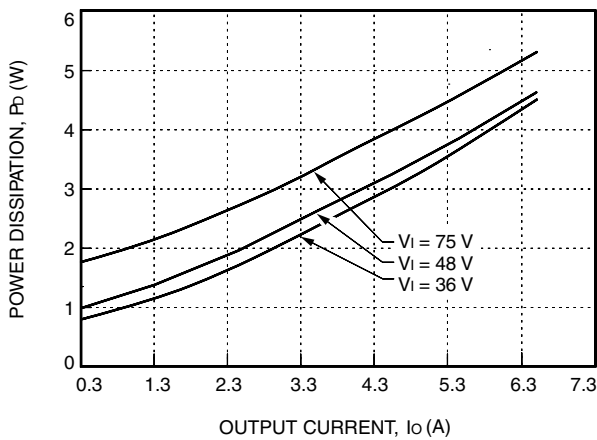

8-9439(C).a

**Figure 11. QW030F Typical Power Dissipation vs. Output Current at TA = 25 °C**

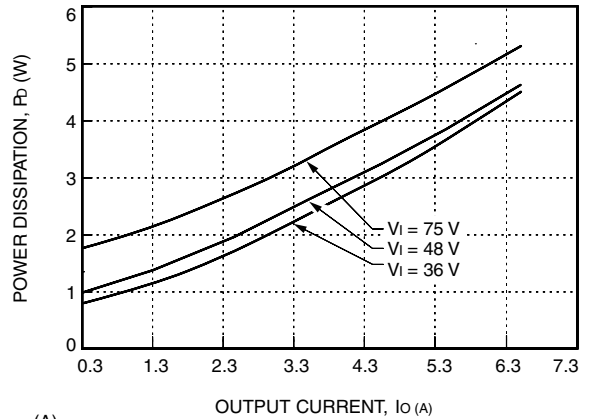

(A)

8-9439(C)

**Figure 12. QW030A Typical Power Dissipation vs. Output Current at TA = 25 °C**

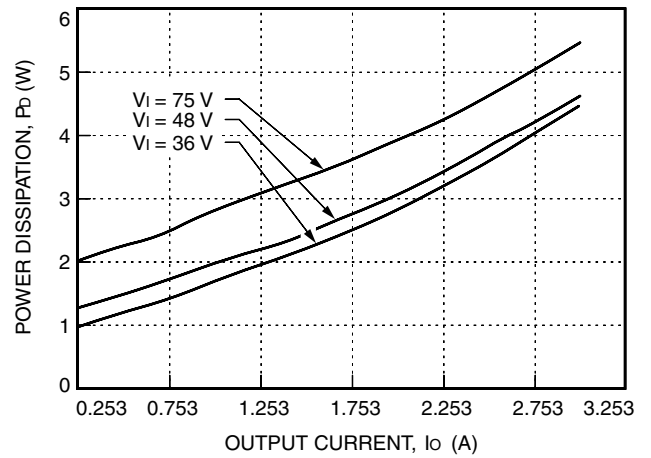

8-3376(C)

**Figure 13. QW030B Typical Power Dissipation vs. Output Current at TA = 25 °C**

## Thermal Considerations (continued)

### Heat Transfer Without Heat Sinks (continued)

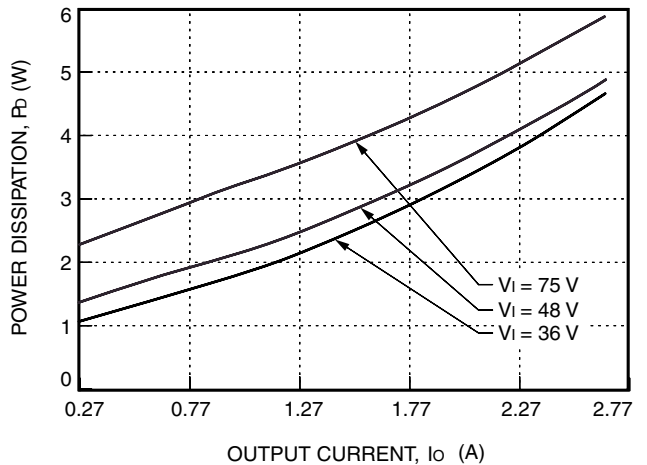

Figure 14. QW030C Typical Power Dissipation vs. Output Current at  $T_A = 25\text{ }^\circ\text{C}$

### Heat Transfer with Heat Sinks

The power modules have through-threaded, M3 x 0.5 mounting holes, which enable heat sinks or cold plates to attach to the module. The mounting torque must not exceed 0.56 N-m (5 in.-lb.). For a screw attachment from the pin side, the recommended hole size on the customer's PWB around the mounting holes is  $0.130 \pm 0.005$  inches. The mounting torque from the pin side must not exceed 0.25 N-m (2.2 in.-lbs.).

Thermal derating with heat sinks is expressed by using the overall thermal resistance of the module. Total module thermal resistance ( $\theta_{ca}$ ) is defined as the maximum case temperature rise ( $\Delta T_{C, \max}$ ) divided by the module power dissipation ( $P_D$ ):

$$\theta_{ca} = \left[ \frac{\Delta T_{C, \max}}{P_D} \right] = \left[ \frac{(T_C - T_A)}{P_D} \right]$$

The location to measure case temperature ( $T_C$ ) is shown in Figure 8. Consult your Tyco Electronics' Account Manager or Application Engineer for case-to-ambient thermal resistance vs. airflow for various heat sink configurations, heights, and orientations. Longitudinal orientation is defined as the long axis of the module that is parallel to the airflow direction, whereas in the transverse orientation, the long axis is perpendicular to the airflow. These curves are obtained by experimental testing of heat sinks, which are offered in the product catalog.

These measured resistances are from heat transfer from the sides and bottom of the module as well as the top side with the attached heat sink; therefore, the case-to-ambient thermal resistances shown are generally lower than the resistance of the heat sink by itself. The module used to collect the data in the case-to-ambient thermal resistance curves had a thermal-conductive dry pad between the case and the heat sink to minimize contact resistance.

### Custom Heat Sinks

A more detailed model can be used to determine the required thermal resistance of a heat sink to provide necessary cooling. The total module resistance can be separated into a resistance from case-to-sink ( $\theta_{cs}$ ) and sink-to-ambient ( $\theta_{sa}$ ) as shown in Figure 15.

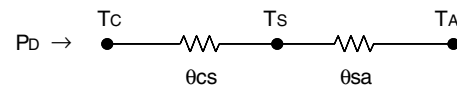

Figure 15. QC/QW030-Series Resistance from Case-to-Sink and Sink-to-Ambient

For a managed interface using thermal grease or foils, a value of  $\theta_{cs} = 0.1\text{ }^\circ\text{C/W}$  to  $0.3\text{ }^\circ\text{C/W}$  is typical. The solution for heat sink resistance is:

$$\theta_{sa} = \left[ \frac{(T_C - T_A)}{P_D} \right] - \theta_{cs}$$

This equation assumes that all dissipated power must be shed by the heat sink. Depending on the user-defined application environment, a more accurate model, including heat transfer from the sides and bottom of the module, can be used. This equation provides a conservative estimate for such instances.

### Layout Considerations

Copper paths must not be routed beneath the power module standoffs. For additional layout guidelines, refer to the FLTR100V10 or FLTR100V20 data sheet.

## Outline Diagram

Dimensions are in millimeters and (inches).

Tolerances:  $x.x \text{ mm} \pm 0.5 \text{ mm}$  ( $x.xx \text{ in.} \pm 0.02 \text{ in.}$ )  
 $x.xx \text{ mm} \pm 0.25 \text{ mm}$  ( $x.xxx \text{ in.} \pm 0.010 \text{ in.}$ )

### Top View

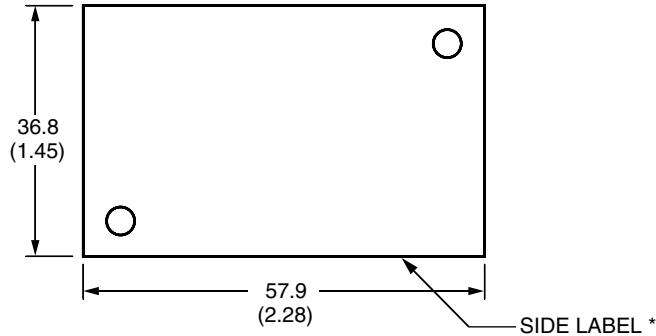

### Side View

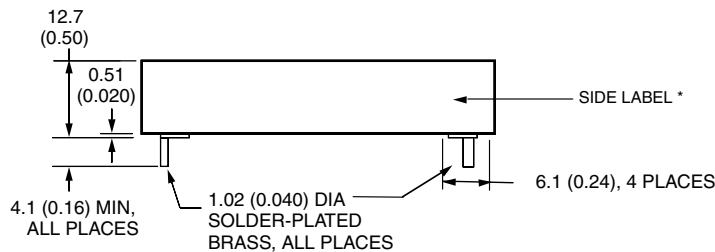

### Bottom View

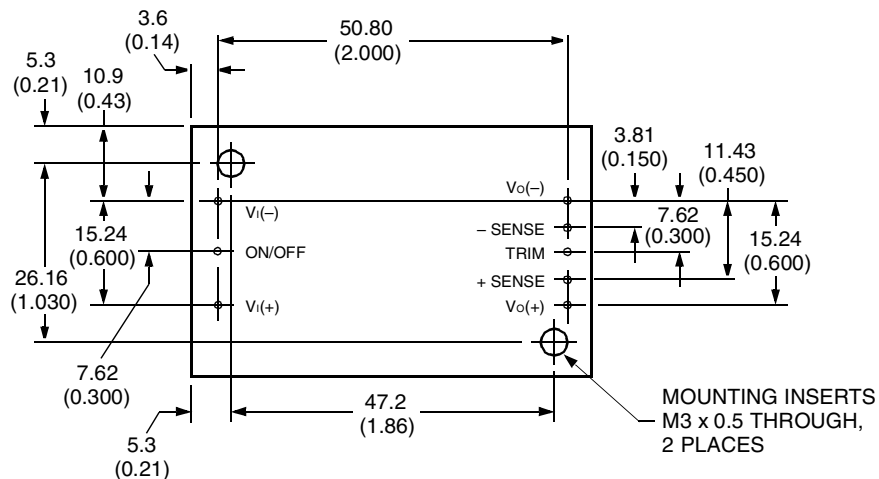

8-1769(F),c

\* Side label includes Tyco name, product designation, safety agency markings, input/output voltage and current ratings, and bar code.

## Recommended Hole Pattern

Component-side footprint.

Dimensions are in millimeters and (inches).

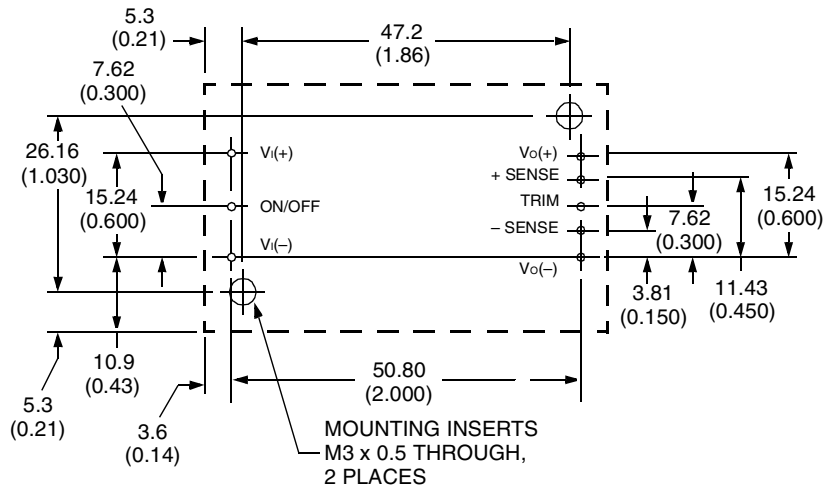

8-1769(F),c

## Ordering Information

Please contact your Tyco Electronics' Account Manager or Field Application Engineer for pricing and availability.

**Table 6. Device Codes**

Input Voltage	Output Voltage	Output Power	Output Current	Remote On/Off Logic	Device Code	Comcode
48 Vdc	3.3 Vdc	21.5 W	6.5 A	Negative	QW030F1	108729807
48 Vdc	5 Vdc	30 W	6 A	Negative	QW030A1	108748344
48 Vdc	12 Vdc	36 W	3 A	Negative	QW030B1	108846171
48 Vdc	15 Vdc	40 W	2.66 A	Negative	QW030C1	108729799
48 Vdc	3.3 Vdc	21.5 W	6.5 A	Positive	QW030F	TBD
48 Vdc	5 Vdc	30 W	6 A	Positive	QW030A	108710765
48 Vdc	12 Vdc	36 W	3 A	Positive	QW030B	TBD
48 Vdc	15 Vdc	40 W	2.66 A	Positive	QW030C	TBD

**Table 7. Device Options**

Option	Device Code Suffix
Short pins: 2.79 mm ± 0.25 mm (0.110 in. ± 0.010 in.)	8
Short pins: 3.68 mm ± 0.25 mm (0.145 in. ± 0.010 in.)	6
Remote On/Off Logic - (Negative)	1

## Device Accessories

Accessory	Comcode
1/4 in. transverse kit (heat sink, thermal pad, and screws)	848060992
1/4 in. longitudinal kit (heat sink, thermal pad, and screws)	848061008
1/2 in. transverse kit (heat sink, thermal pad, and screws)	848061016
1/2 in. longitudinal kit (heat sink, thermal pad, and screws)	848061024
1 in. transverse kit (heat sink, thermal pad, and screws)	848061032
1 in. longitudinal kit (heat sink, thermal pad, and screws)	848061040

Dimensions are in millimeters and (inches).

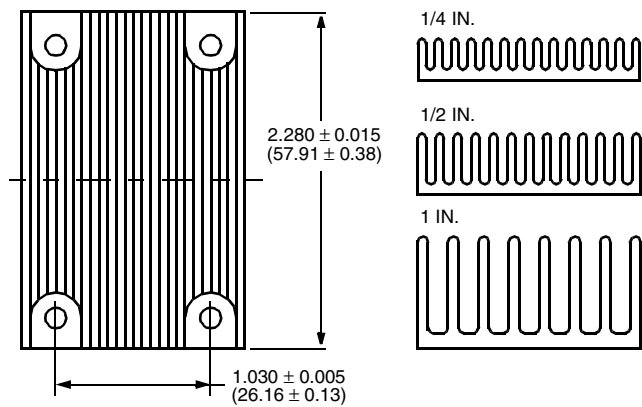

8-2473(F)

Figure 16. QC/QW030-Series Longitudinal Heat Sink

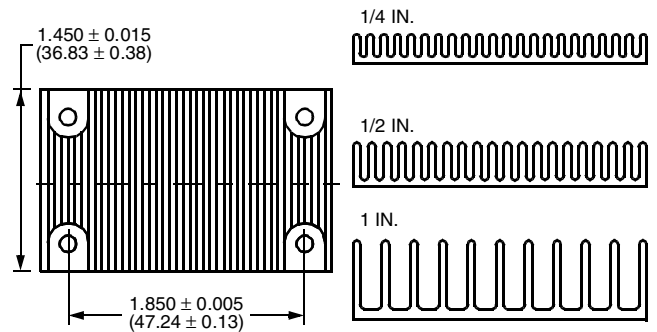

8-2472(F)

Figure 17. QC/QW030-Series Transverse Heat Sink



**World Wide Headquarters**

**Tyco Electronics Power Systems, Inc.**

3000 Skyline Drive, Mesquite, TX 75149, USA

+1-800-526-7819 FAX: +1-888-315-5182

(Outside U.S.A.: +1-972-284-2626, FAX: +1-972-284-2900)

[www.power.tycoelectronics.com](http://www.power.tycoelectronics.com)

**e-mail: [techsupport1@tycoelectronics.com](mailto:techsupport1@tycoelectronics.com)**

**Europe, Middle-East and Africa Headquarters**

Tyco Electronics (UK) Ltd

Tel: +44 (0) 1344 469 300, Fax: +44 (0) 1344 469 301

**Central America-Latin America Headquarters**

Tyco Electronics Power Systems

Tel: +54 11 4316 2866, Fax: +54 11 4312 9508

**Asia-Pacific Headquarters**

Tyco Electronics Singapore Pte Ltd

Tel: +65 482 0311, Fax: 65 480 9299

---

Tyco Electronics Corporation reserves the right to make changes to the product(s) or information contained herein without notice. No liability is assumed as a result of their use or application. No rights under any patent accompany the sale of any such product(s) or information.

© 2001 Tyco Electronics Power Systems, Inc. (Mesquite, Texas) All International Rights Reserved.  
Printed in U.S.A.

April 2002  
FDS01-041EPS (Replaces DS00-246EPS)

