



STMPE2403

24-bit Enhanced port expander with Keypad and PWM controller
Xpander logic

Features

- 24 GPIOs
- Operating voltage 1.8V
- Hardware keypad controller (8*12 matrix max)
- 8 Special Function Key support
- 3 PWM (8 bit) output for LED brightness control and blinking
- Interrupt output (open drain) pin
- Configurable hotkey feature on each GPIO
- Ultra-low Standby-mode current
- Package TFBGA - 36 pins 3.6x3.6mm, pitch 0.5mm

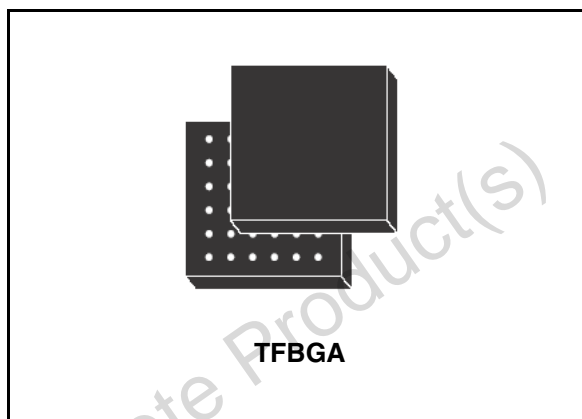

Description

The STMPE2403 is a GPIO (General Purpose Input / Output) port expander able to interface a Main Digital ASIC via the two-line bidirectional bus (I²C); separate GPIO Expander IC is often used in Mobile-Multimedia platforms to solve the problems of the limited amounts of GPIOs usually available on the Digital Engine.

The STMPE2403 offers great flexibility as each I/Os is configurable as input, output or specific functions; it's able to scan a keyboard, also provides PWM outputs for brightness control in backlight, rotator decoder interface and GPIO. This device has been designed very low quiescent current, and is including a wake up feature for each I/O, to optimize the power consumption of the IC.

Potential application of the STMPE2403 includes portable media player, game console, mobile phone, smart phone

Table 1. Device summary

Part Number	Package	Packaging
STMPE2403TBR	TFBGA36	Tape and reel

Contents

1	Block diagram	5
2	Pin settings	6
2.1	Pin connection	6
2.2	Pin assignment and TFBGA ball location	6
2.3	GPIO Pin functions	8
2.4	Pin mapping to TFBGA (bottom view, balls up)	9
3	Maximum rating	10
3.1	Absolute maximum rating	10
3.2	Thermal data	10
4	Electrical specification	11
4.1	DC electrical characteristics	11
4.2	I/O DC electrical characteristics	11
4.3	DC input specification	12
4.4	DC output specification	12
4.5	AC characteristics	12
5	Register map	13
6	I2C Interface	14
6.1	Start condition	14
6.2	Stop condition	14
6.3	Acknowledge bit (ACK)	14
6.4	Data input	14
6.5	Slave device address	15
6.6	Memory addressing	15
6.7	Operation modes	16
6.8	General call address	17

7	System controller	18
7.1	Identification register	18
7.2	System control register	19
7.3	System control register 2	20
7.4	States of operation	21
7.5	Autosleep	22
7.6	Keypress detect in the hibernate mode	22
8	Clocking system	23
8.1	Clock source	23
8.2	Power mode programming sequence	24
9	Interrupt system	25
9.1	Register map of interrupt system	26
9.2	Interrupt Control Register (ICR)	27
9.3	Interrupt Enable Mask Register (IER)	28
9.4	Interrupt Status Register (ISR)	29
9.5	Interrupt Enable GPIO Mask Register (IEGPIOR)	29
9.6	Interrupt Status GPIO Register (ISGPIOR)	30
9.7	Programming sequence	31
10	GPIO controller	32
10.1	GPIO control registers	33
10.2	GPIO Alternate Function Register (GPAFR)	35
10.3	Hot key feature	37
10.3.1	Programming sequence for Hot Key	37
10.3.2	Minimum pulse width	37
10.4	MUX Control Register (MCR)	38
10.5	STMPE2401 Pin Compatibility Register (COMPAT2401)	39

11	PWM controller	40
11.1	Registers in the PWM controller	41
11.2	PWM Control and Status Register (PWMCS)	42
11.3	PWM Instruction Channel x (PWMICx)	43
11.4	PWM commands	43
12	Keypad controller	46
12.1	Keypad configurations	47
12.2	Registers in keypad controller	48
12.3	KPC_col register	49
12.4	KPC_row_msb register	49
12.5	KPC_row_lsb register	50
12.6	KPC_ctrl_msb register	50
12.7	KPC_ctrl_lsb register	51
12.8	Data registers	51
12.8.1	Resistance	54
12.8.2	Using the keypad controller	54
12.8.3	Ghost Key Handling	54
12.8.4	Priority of Key detection	55
12.8.5	Keypad Wake-Up from sleep and hibernate modes	55
13	Rotator controller	56
14	Miscellaneous features	58
14.1	Reset	58
14.2	Under Voltage Lockout	58
14.3	Clock output	58
14.4	Crystal oscillator	58
15	Package mechanical data	59
16	Revision history	62

1 Block diagram

Figure 1. Block diagram

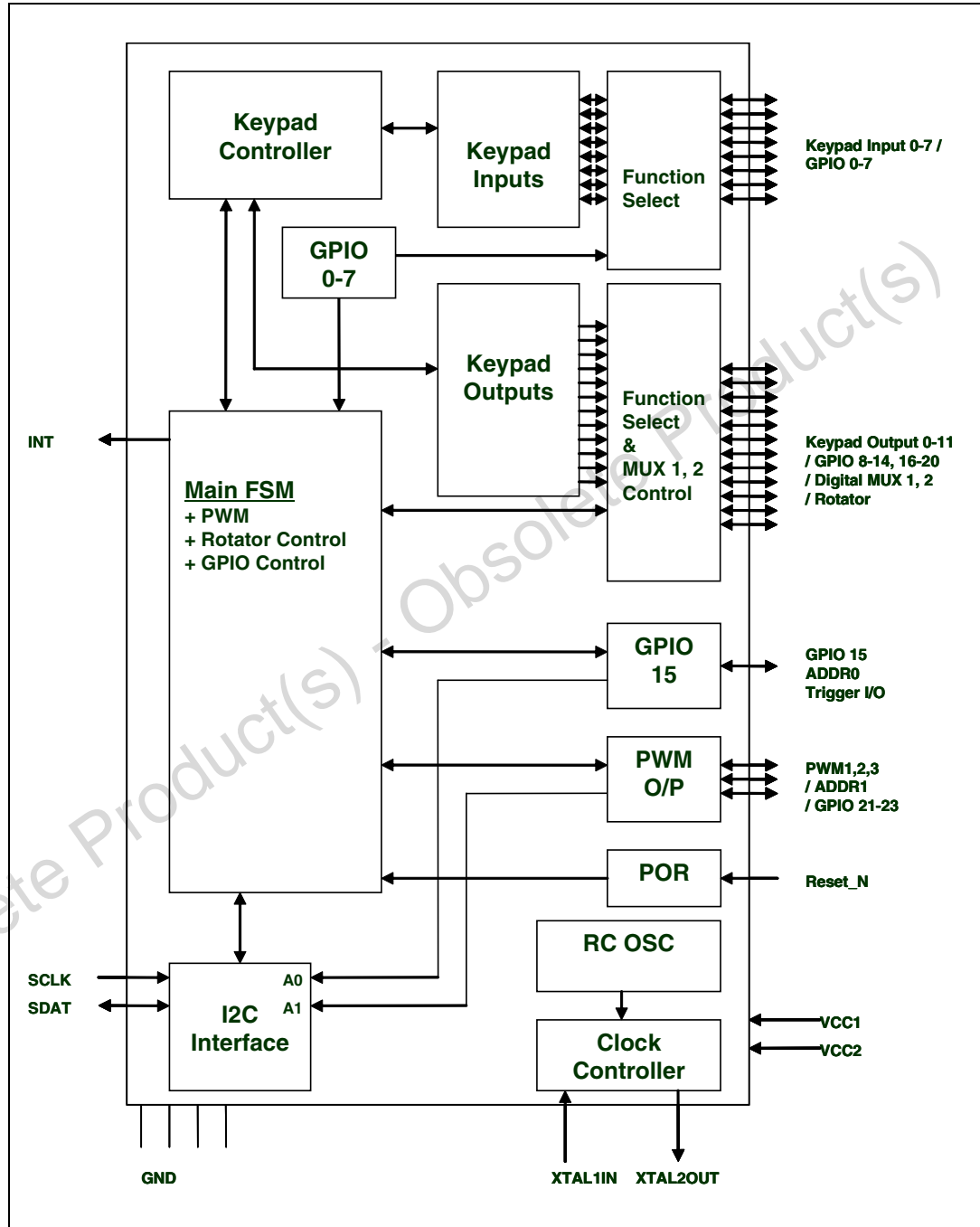

2 Pin settings

2.1 Pin connection

Figure 2. Pin connection

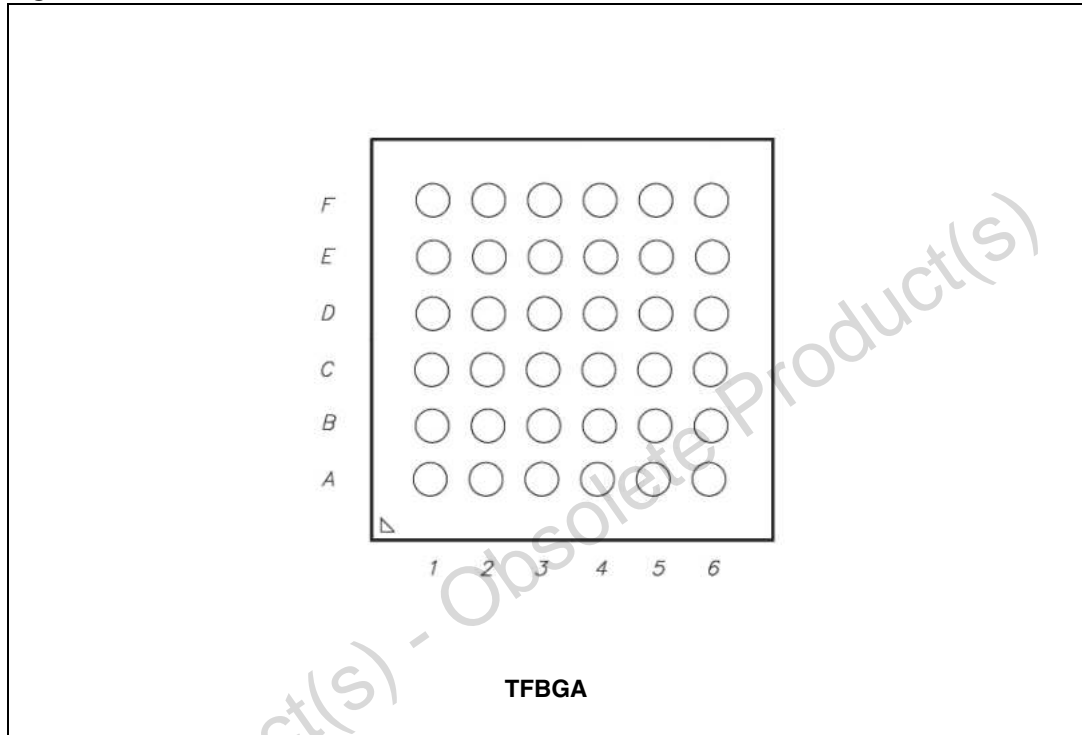

2.2 Pin assignment and TFBGA ball location

Table 2. Pin assignment

Ball	Name	Type	Description
C3	GND1	-	
A6	KP_X0	IO	GPIO
C1	Reset_N	I	External reset input, active LOW
A5	KP_X1	IO	GPIO
F1	KP_X2	IO	GPIO
F2	KP_X3	IO	GPIO
A2	KP_X4	IO	GPIO
B3	KP_X5	IO	GPIO
A3	KP_X6	IO	GPIO
D3	GND2	-	
A4	VCC1	-	1.8V Input

Table 2. Pin assignment (continued)

Ball	Name	Type	Description
B4	KP_X7	IO	GPIO
A1	KP_Y5	IO	GPIO
B2	KP_Y4	IO	GPIO
B5	KP_Y3	IO	GPIO
B6	KP_Y2	IO	GPIO
C5	KP_Y1	IO	GPIO
C6	KP_Y0	IO	GPIO
C4	GND3	-	
D6	ADDR0	IO	GPIO and I2C ADDR 0 (in reset)
D5	KP_Y9	A/IO	GPIO/MUX
E6	KP_Y10	A/IO	GPIO/MUX
F6	KP_Y11	A/IO	GPIO/MUX
E5	PWM3	A/IO	GPIO and I2C ADDR 1 (in reset) /MUX
F5	PWM2	A/IO	GPIO/MUX
E4	PWM1	A/IO	GPIO/MUX
F4	VCC2	-	1.8V Input
D4	GND4	-	
F3	INT	O	Open drain interrupt output pin
E3	KP_Y8	IO	GPIO
C2	KP_Y7	IO	GPIO
B1	KP_Y6	IO	GPIO
E2	SDATA	A	I2C DATA
E1	SCLK	A	I2C Clock
D2	XTALIN	A	XTAL Oscillator or External 32KHz input. be left floating.
D1	XTALOUT	A	XTAL Oscillator

2.3 GPIO Pin functions

Table 3. GPIO Pin functions

Name	Primary Function	Alternate Function 1	Alternate Function 2	Alternate Function 3
KP_X0	GPIO 0	Keypad input 0		
KP_X1	GPIO 1	Keypad input 1		
KP_X2	GPIO 2	Keypad input 2		
KP_X3	GPIO 3	Keypad input 3		
KP_X4	GPIO 4	Keypad input 4		
KP_X5	GPIO 5	Keypad input 5		
KP_X6	GPIO 6	Keypad input 6		
KP_X7	GPIO 7	Keypad input 7		
KP_Y5	GPIO 13	Keypad Output 5		
KP_Y4	GPIO 12	Keypad Output 4		
KP_Y3	GPIO 11	Keypad Output 3		
KP_Y2	GPIO 10	Keypad Output 2		
KP_Y1	GPIO 9	Keypad Output 1		
KP_Y0	GPIO 8	Keypad Output 0		
ADDR0	GPIO 15			
KP_Y9	GPIO 18	Keypad Output 9	Rotator 0	Mux1_In_1
KP_Y10	GPIO 19	Keypad Output 10	Rotator 1	Mux1_In_2
KP_Y11	GPIO 20	Keypad Output 11	Rotator 2	Mux1_Out
PWM3	GPIO 23			Mux2_Out
PWM2	GPIO 22			Mux2_In_2
PWM1	GPIO 21			Mux2_In_1
KP_Y8	GPIO 17	Keypad Output 8		ClkOut
KP_Y7	GPIO 16	Keypad Output 7		
KP_Y6	GPIO 14	Keypad Output 6		

2.4 Pin mapping to TFBGA (bottom view, balls up)

Table 4. Pin mapping to TFBGA (bottom view, balls up)

	A	B	C	D	E	F
1	KP_Y5	KP_Y6	RESET	XTALOUT	SCLK	KP_X2
2	KP_X4	KP_Y4	KP_Y7	XTALIN	SDATA	KP_X3
3	KP_X6	KP_X5	GND1	GND2	KP_Y8	INT
4	VCC1	KP_X7	GND3	GND4	PWM-1	VCC2
5	KP_X1	KP_Y3	KP_Y1	KP_Y9	PWM-3	PWM-2
6	KP_X0	KP_Y2	KP_Y0	ADDR0	KP_Y10	KP_Y11

3 Maximum rating

Stressing the device above the rating listed in the “Absolute Maximum Ratings” table may cause permanent damage to the device. These are stress ratings only and operation of the device at these or any other conditions above those indicated in the Operating sections of this specification is not implied. Exposure to Absolute Maximum Rating conditions for extended periods may affect device reliability. Refer also to the STMicroelectronics SURE Program and other relevant quality documents.

3.1 Absolute maximum rating

Table 5. Absolute maximum rating

Symbol	Parameter	Value	Unit
V_{CC}	Supply voltage	2.5	V
V_{IN}	Input voltage on GPIO pin	2.5	V
$V_{IN I2C}$	Input voltage on I2C pin	4.5	V
VESD (HBM)	ESD protection on each GPIO pin	2	KV

3.2 Thermal data

Table 6. Thermal data

Symbol	Parameter	Min	Typ	Max	Unit
R_{thJA}	Thermal resistance junction-ambient		100		°C/W
T_A	Operating ambient temperature	-40	25	85	°C
T_J	Operating junction temperature	-40	25	125	°C

4 Electrical specification

4.1 DC electrical characteristics

Table 7. DC electrical characteristics

Symbol	Parameter	Test conditions	Value			Unit
			Min.	Typ.	Max.	
VCC1,2	Supply voltage		1.65	1.8	1.95	V
I _{HIBERNATE1}	HIBERNATE mode current	XTALIN not floating		15	20	uA
I _{HIBERNATE2}	HIBERNATE mode current	XTALIN floating		35	40	uA
I _{SLEEP1}	SLEEP mode current	XTALIN not floating		55	100	uA
I _{SLEEP2}	SLEEP mode current	XTALIN floating		75	120	uA
I _{cc}	Operating current (FSM working – No peripheral activity)			1.2	1.6	mA
INT	Open drain output current			4		mA

4.2 I/O DC electrical characteristics

The 1.8V I/O complies to the EIA/JEDEC standard JESD8-7.

Table 8. I/O DC electrical characteristic

Symbol	Parameter	Value			Unit
		Min.	Typ.	Max.	
V _{il}	Low level input voltage			0.35*V _{cc} = 0.63	V
V _{ih}	High level input voltage	0.65*V _{cc} = 1.17			V
V _{hyst}	Schmitt trigger hysteresis		0.10		V

4.3 DC input specification

(1.55V < V_{DD} < 1.95V)

Table 9. DC input specification

Symbol	Parameter	Test conditions	Value			Unit
			Min.	Typ.	Max.	
V _{ol}	Low level output voltage	I _{ol} = 4mA			0.45	V
V _{oh}	High level output voltage	I _{oh} = 4mA	V _{CC} - 0.45 = 1.35			V
V _{ol_PWM}	Low level output voltage	I _{ol} = 16mA			0.45	V
V _{oh_PWM}	High level output voltage	I _{oh} = 16mA	V _{CC} - 0.45 = 1.35			V

4.4 DC output specification

(1.55V < v_{dd} < 1.95V)

Table 10. DC output specification

Symbol	Parameter	Test conditions	Value			Unit
			Min.	Typ.	Max.	
I _{pu}	Pull-up current	V _i = 0V	15	35	65	μA
I _{pd}	Pull-down current	V _i = v _{dd}	14	35	60	μA
R _{up}	Equivalent pull-up resistance	V _i = 0V	30	50	103.3	KΩ
R _{pd}	Equivalent pull-down resistance	V _i = v _{dd}	32.5	50	110.7	KΩ
R _{on_1}	R _{on} when the MUX is ON	V _{signal} = 0V		5	10	Ω
R _{on_2}	R _{on} when the MUX is ON	V _{signal} = 0.9V		5	20	Ω
R _{on_3}	R _{on} when the MUX is ON	V _{signal} = 1.8V		10	10	Ω
R _{on}	R _{on} when the MUX is ON	V _{signal} < 1.8V		20	35	Ω

Note: Pull-up and Pull-down characteristics

4.5 AC characteristics

Table 11. AC characteristics

Symbol	Parameter	Value			Unit
		Min.	Typ.	Max.	
Int_32KHz	Internally generated 32KHz clock	22	28	41.6	KHz

5 Register map

All registers have the size of 8-bit. For each of the module, their registers are residing within the given address range.

Table 12. Register map

Address	Module registers	Description	Auto-Increment (during read/write)
0x00 – 0x07 0x80 – 0x81	Clock and power Manager module	Clock and Power Manager register range.	Yes
0x10 – 0x1F	Interrupt controller module	Interrupt Controller register range	Yes
0x30 – 0x37	PWM controller module	PWM Controller register range	Yes
0x38 – 0x3F		PWM Controller register range	No
0x60 – 0x6F	Keypad controller module	Keypad Controller register range	Yes
0x70 – 0x77	Rotator controller module	Rotator Controller register range	Yes
0x82 – 0xBF	GPIO Controller Module	GPIO Controller register range	Yes

6 I²C Interface

The features that are supported by the I²C interface are as below:

- I²C Slave device
- Operates at 1.8V
- Compliant to Philip I²C specification version 2.1
- Supports Standard (up to 100kbps) and Fast (up to 400kbps) modes.
- 7-bit and 10-bit device addressing modes
- General Call
- Start/Restart/Stop
- Address up to 4 STMPE2403 devices via I²C

The address is selected by the state of two pins. The state of the pins will be read upon reset and then the pins can be configured for normal operation. The pins will have a pull-up or down to set the address. The I²C interface module allows the connected host system to access the registers in the STMPE2403.

6.1 Start condition

A Start condition is identified by a falling edge of SDATA while SCLK is stable at high state. A Start condition must precede any data/command transfer. The device continuously monitors for a Start condition and will not respond to any transaction unless one is encountered.

6.2 Stop condition

A Stop condition is identified by a rising edge of SDATA while SCLK is stable at high state. A Stop condition terminates communication between the slave device and bus master. A read command that is followed by NoAck can be followed by a Stop condition to force the slave device into idle mode. When the slave device is in idle mode, it is ready to receive the next I²C transaction. A Stop condition at the end of a write command stops the write operation to registers.

6.3 Acknowledge bit (ACK)

The acknowledge bit is used to indicate a successful byte transfer. The bus transmitter releases the SDATA after sending eight bits of data. During the ninth bit, the receiver pulls the SDATA low to acknowledge the receipt of the eight bits of data. The receiver may leave the SDATA in high state if it would to *not* acknowledge the receipt of the data.

6.4 Data input

The device samples the data input on SDATA on the rising edge of the SCLK. The SDATA signal must be stable during the rising edge of SCLK and the SDATA signal must change only when SCLK is driven low.

6.5 Slave device address

The slave device address is a 7 or 10-bit address, where the least significant 2-bit are programmable. These 2-bit values will be loaded in once upon reset and after that these 2 pins no longer be needed with the exception during General Call. Up to 4 STMPE2403 devices can be connected on a single I²C bus.

Table 13. Slave device address

ADDR 1	ADDR 0	Address
0	0	0x84
0	1	0x86
1	0	0x88
1	1	0x8A

6.6 Memory addressing

For the bus master to communicate to the slave device, the bus master must initiate a Start condition and followed by the slave device address. Accompanying the slave device address, there is a Read/Write bit (R/W). The bit is set to 1 for Read and 0 for Write operation.

If a match occurs on the slave device address, the corresponding device gives an acknowledgement on the SDA during the 9th bit time. If there is no match, it deselects itself from the bus by not responding to the transaction.

6.7 Operation modes

Table 14. Operation modes

Mode	Bytes	Programming Sequence
Read	≥1	START, Device Address, R/W = 0, Register Address to be read
		reSTART, Device Address, R/W = 1, Data Read, STOP
<p>If no STOP is issued, the Data Read can be continuously performed. If the register address falls within the range that allows address auto-increment, then register address auto-increments internally after every byte of data being read. For register address that falls within a non-incremental address range, the address will be kept static throughout the entire read operations. Refer to the Memory Map table for the address ranges that are auto and non-increment. An example of such a non-increment address is FIFO.</p>		
Write	≥1	START, Device Address, R/W = 0, Register Address to be written, Data Write, STOP
		<p>If no STOP is issued, the Data Write can be continuously performed. If the register address falls within the range that allows address auto-increment, then register address auto-increments internally after every byte of data being written in. For register address that falls within a non-incremental address range, the address will be kept static throughout the entire write operations. Refer to the Memory Map table for the address ranges that are auto and non-increment. An example of a non-increment address is Data Port for initializing the PWM commands.</p>

Figure 3. Master/slave operation modes

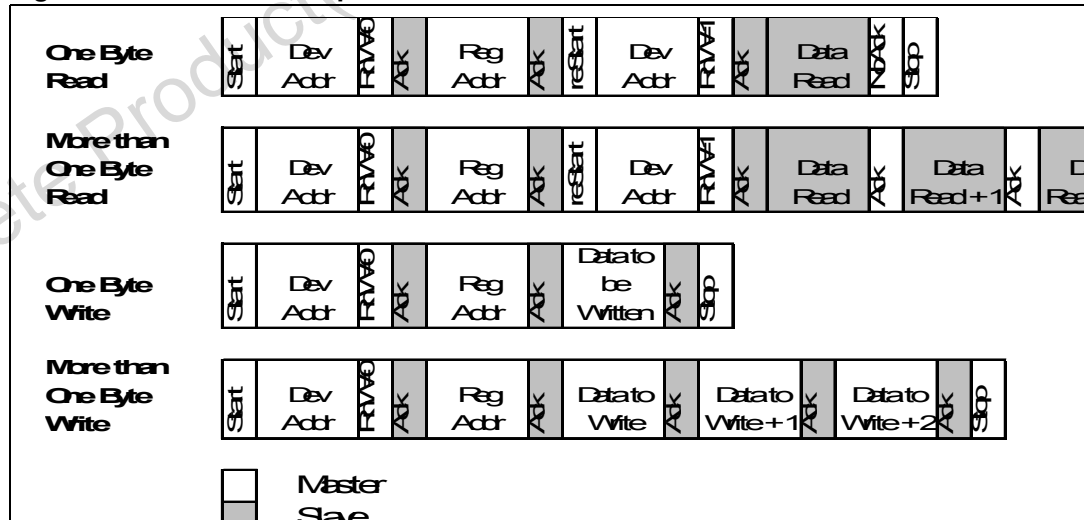

6.8 General call address

A general call address is a transaction with the slave address of 0x00 and $R/\overline{W} = 0$. When a general call address is made, STMPE2403 responds to this transaction with an acknowledgement and behaves as a slave-receiver mode. The meaning of a general call address is defined in the second byte sent by the master-transmitter.

Table 15.

R/ \overline{W}	Second byte value	Definition
0	0x06	2-byte transaction in which the second byte tells the slave device to reset and write (or latch in) the 2-bit programmable part of the slave address.
0	0x04	2-byte transaction in which the second byte tells the slave device not to reset and write (or latch in) the 2-bit programmable part of the slave address.
0	0x00	Not allowed as second byte.

Note: All other second byte value will be ignored.

7 System controller

The system controller is the heart of the STMPE2403. It contains the registers for power control, and the registers for chip identification.

The system registers are:

Table 16. System controller

Address	Register_Name
0x00	Reserved (Reads 0x00)
0x01	Reserved (Reads 0x00)
0x02	SYSCON
0x03	SYSCON2
0x80	CHIP_ID
0x81	VERSION_ID
0x82	Reserved (Reads 0x00)

7.1 Identification register

Table 17. CHIP_ID

Bit	7	6	5	4	3	2	1	0
	8-bit LSB of Chip ID							
Read/Write(IIC)	R	R	R	R	R	R	R	R
Reset Value	0	0	0	0	0	0	0	1

Table 18. VERSION_ID

Bit	7	6	5	4	3	2	1	0
	8-bit Version ID							
Read/Write(IIC)	R	R	R	R	R	R	R	R
Reset Value	0	0	0	0	0	0	1	0

7.2 System control register

Table 19. System control register

Bit	7	6	5	4	3	2	1	0
	Soft_Reset	Clock_Source	Disable_32KHz	Sleep	Enable_GPIO	Enable_PWM	Enable_KPC	Enable_ROT
Read/Write (IIC)	W	RW	RW	RW	RW	RW	RW	RW
Reset Value	0	0	0	0	1	1	1	1

Table 20. System control register writing

Bits	Name	Description
0	Enable_ROT	Writing a '0' to this bit will gate off the clock to the Rotator module, thus stopping its operation
1	Enable_KPC	Writing a '0' to this bit will gate off the clock to the Keypad Controller module, thus stopping its operation
2	Enable_PWM	Writing a '0' to this bit will gate off the clock to the PWM module, thus stopping its operation
3	Enable_GPIO	Writing a '0' to this bit will gate off the clock to the GPIO module, thus stopping its operation
4	Sleep	Writing a '1' to this bit will put the device in sleep mode. When in sleep mode, all the units will work on 32KHz (typical) clock frequency.
5	Disable_32KHz	Set this bit to disable the 32KHz OSC, thus putting the device in hibernate mode. Only a Reset or a wakeup on IIC will reset this bit
6	Clock_Source	Set to '1' if external 32KHz clock were to be used. '0' by default.
7	Soft_Reset	Writing a '1' to this bit will do a soft reset of the device. Once the reset is done, this bit will be cleared to '0' by the HW.

7.3 System control register 2

Table 21. System control register 2

Bit	7	6	5	4	3	2	1	0
	Reserved	Reserved	Reserved	Reserved	AutoSleepEN	Sleep_2	Sleep_1	Sleep_0
Read/ Write (IIC)	R	R	R	R	RW	RW	RW	RW
Reset Value	0	0	0	0	0	0	0	0

Table 22. System control register 2

Bits	Name	Description
0	Sleep_0	"000" for 4mS delay
1	Sleep_1	"001" for 16mS delay "010" for 32mS delay
2	Sleep_2	"011" for 64mS delay "100" for 128mS delay "101" for 256mS delay "110" for 512mS delay "111" for 1024mS delay
3	AutoSleepEN	"1" to enable auto-sleep feature. "0" to disable auto-sleep.
4	Reserved	
5	Reserved	
6	Reserved	
7	Reserved	

7.4 States of operation

The device has three main modes of operation:

- **Operational Mode:** This is the mode, whereby normal operation of the device takes place. In this mode, the RC clock is available and the Main FSM Unit routes this clock and the 32 KHz clock to all the device blocks that are enabled. In this mode, individual blocks that need not be working can be turned off by the master by programming the bits 3 to 0 of the SYSCON register.
- **Sleep Mode:** In this low-power mode, individual blocks can be turned off by the master by programming the bits 3 to 0 of the SYSCON register. However, the master needs to program the SYSCON register before coming into this mode, as in the sleep mode, the IIC interface is not active except to detect traffic for wakeup. Any activity on the I2C port (intended I2C transaction for the device) or Wakeup pin or Hotkey activity will cause the device to leave this mode and go into the Operational mode. When leaving this mode, the I2C will need to hold the SCLK till the RC clock is ready.
- **Hibernate Mode:** This mode is entered when the system writes a '1' to bit 5 of the SYSCON register. In this mode, the device is completely inactive as there is absolutely no clock. Only a Reset or a wakeup on IIC will bring back the System to operational mode. A keypress detect will bring the system to Sleep mode, in which the debounce of the key will take place.

Note: 32KHz clock mentioned in this section could be (1) External clock from connected XTAL, (2) Externally fed 32KHz clock, or (3) internally generated (from RC OSC) clock. In the case that internal clock is used, it has a range of 25KHz to 45KHz.

Caution: Hotkey detection is not possible in hibernate mode.

Figure 4. States of operation

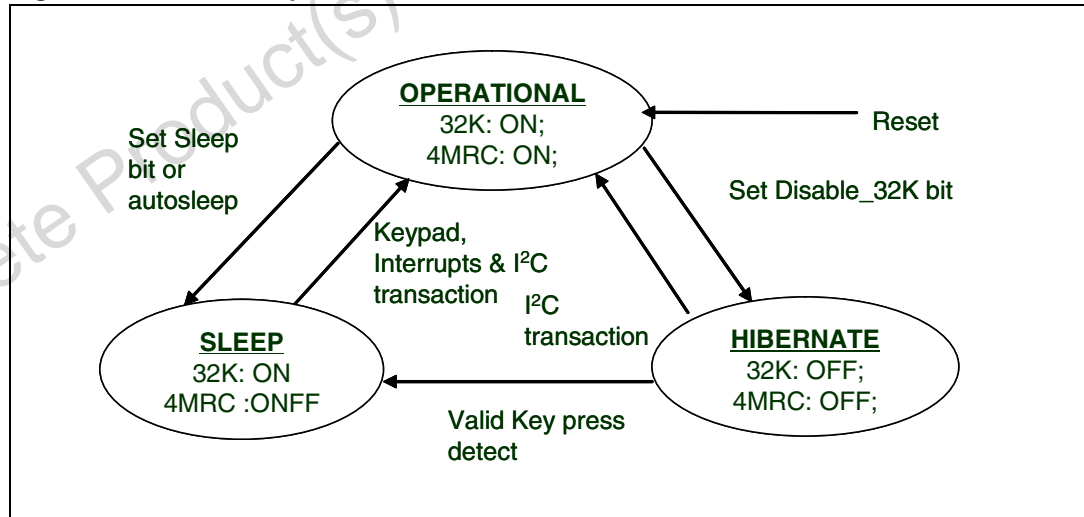

7.5 Autosleep

Host system may configure the STMPE2403 to go into sleep mode automatically whenever there is a period of inactivity following a complete I2C transaction with the STMPE2403. This inactivity means there is no intended I2C transaction for the device. For example, if there is I2C transaction sent by the host to other slave devices, the STMPE2403 device will still be counting down for the auto-sleep. The STMPE2403 device resets the autosleep time-out counter only when it receives an I2C transaction meant for the device itself. This autosleep feature is controlled by the System Control Register 2.

All events that trigger an interrupt (KPC, Rotator controller, Hot-Key) would result in a transition from SLEEP state to OPERATIONAL state automatically. The wake up can also be performed through I2C transaction intended for the device.

7.6 Keypress detect in the hibernate mode

When in hibernate mode, a keypress detect will cause the system to go into sleep mode. The sleep clock (32KHz) will then be used to debounce the key to detect a valid key. If the keypress is detected to be valid, the system stay in the sleep mode. If the key is detected to be invalid, the system will go back into hibernate mode.

8 Clocking system

Figure 5. Clocking system

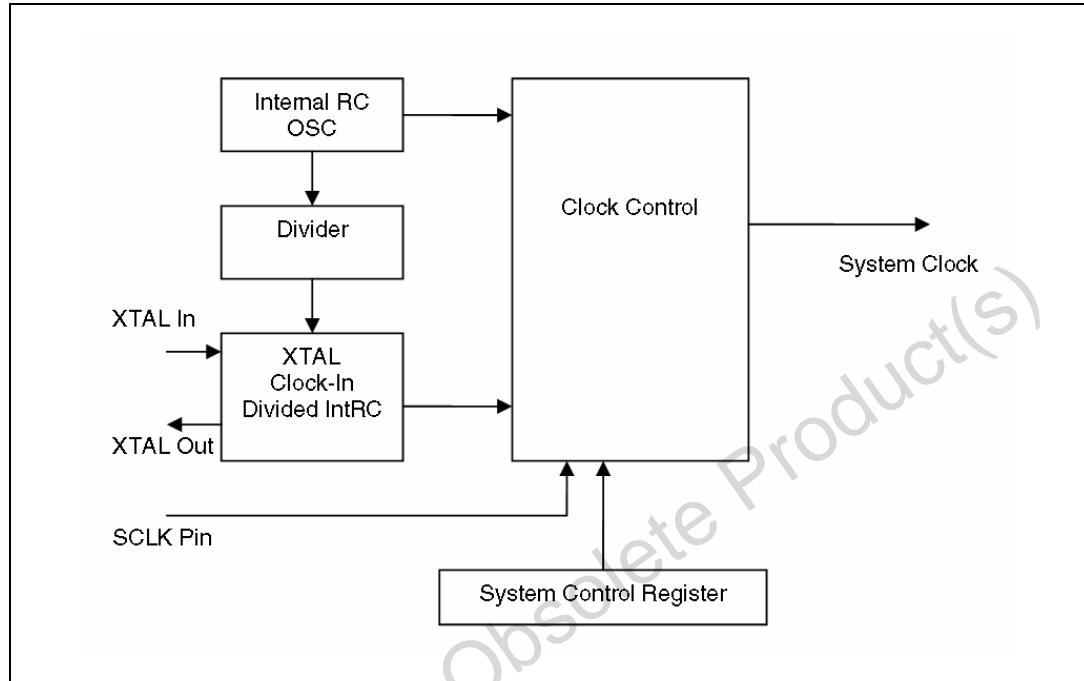

The decision on clocks is based on the bits written into SYSCON registers. Bits 0 to 4 of the SYSCON register control the gating of clocks to the Rotator, Keypad Controller, PWM and GPIO respectively in the operational mode.

8.1 Clock source

By default, when the STMPE2403 powers up, it derives a 32KHz clock from the internal RC oscillator for its operation. If external 32KHz crystal or clock source is available, it must be configured to accept external clock through the SYSCON register.

In the case where the STMPE2403 is powered and configured to use external clock, and the XTALIN is left floating, there will be an additional leakage current of approximately 20µA drawn from the V_{CC}.

8.2 Power mode programming sequence

To put the device in sleep mode, the following needs to be done by the host:

Write a '1' to bit 4 of the SYSCON register.

To wakeup the device, the following needs to be done by the host:

Assert a wakeup routine on the I2C bus by sending the Start Bit, followed by the device address and the Write bit. Subsequently, proceed with sending the Base Register address and continue with a normal I2C transaction. The device wakes up upon receiving the correct device address and in Write direction. In other words, the procedure of waking up the device is performed by just sending an I2C transaction to the device. This procedure can be extended to wake up the device that is in hibernate mode.

To do a soft reset to the device, the host needs to do the following:

Write a '1' to bit 7 of the SYSCON register.

This bit is automatically cleared upon reset.

To go into Hibernate mode, the following needs to be done by the host:

Set the Disable_32K bit to '1'

To come out of the Hibernate mode, the following needs to be done by the host:

Assert a system reset or

Put a wakeup on the I2C

9 Interrupt system

STMPE2403 uses a highly flexible interrupt system. It allows host system to configure the type of system events that should result in an interrupt, and pinpoints the source of interrupt by status register. The INT pin could be configured as ACTIVE HIGH, or ACTIVE LOW.

Once asserted, the INT pin would de-assert only if the corresponding bit in the Interrupt Status register is cleared.

Figure 6. Interrupt system

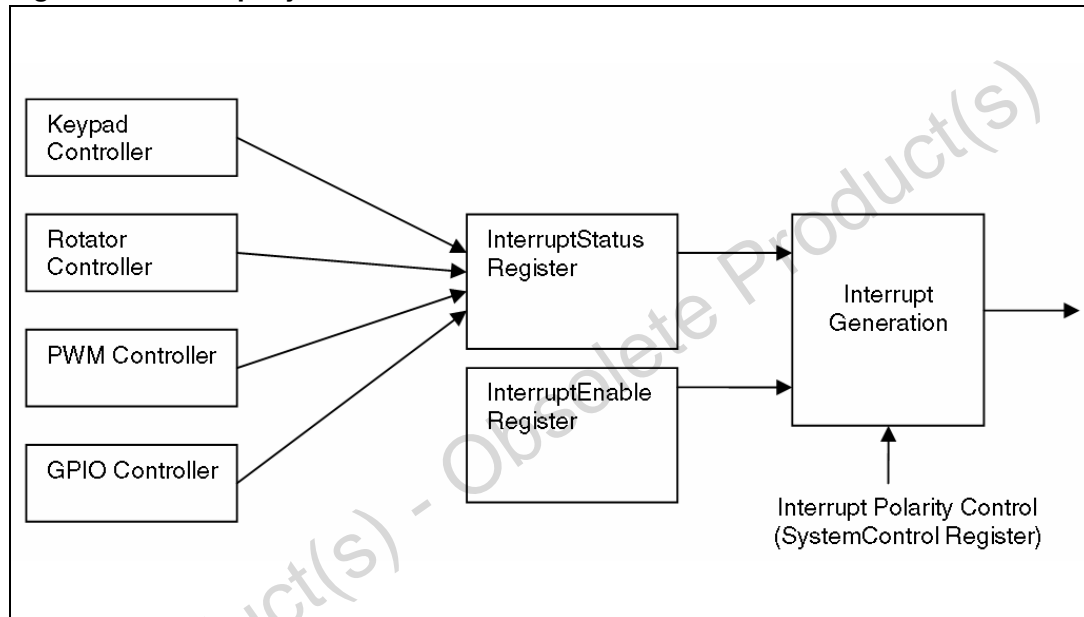

9.1 Register map of interrupt system

Table 23. Register map of interrupt system

Address	Register name	Description	Auto-Increment (during sequential R/W)
0x10	ICR_msb	Interrupt Control Register	Yes
0x11	ICR_lsb		Yes
0x12	IER_msb	Interrupt Enable Mask Register	Yes
0x13	IER_lsb		Yes
0x14	ISR_msb	Interrupt Status Register	Yes
0x15	ISR_lsb		Yes
0x16	IEGPIOR_msb	Interrupt Enable GPIO Mask Register	Yes
0x17	IEGPIOR_csb		Yes
0x18	IEGPIOR_lsb		Yes
0x19	ISGPIOR_msb	Interrupt Status GPIO Register	Yes
0x1A	ISGPIOR_csb		Yes
0x1B	ISGPIOR_lsb		Yes

9.2 Interrupt Control Register (ICR)

ICR register is used to configure the Interrupt Controller. It has a global enable interrupt mask bit that controls the interruption to the host.

	ICR_msb											ICR_lsb				
Bit	15	14	13	12	11	10	9	8	7	6	5	4	3	2	1	0
	Reserved											IC2	IC1	IC0		
R/W	R	R	R	R	R	R	R	R	R	R	R	R	R	RW	RW	RW
Reset Value	0	0	0	0	0	0	0	0	0	0	0	0	0	0	0	0

Table 24. Register description

Bit	Name	Description
0	IC[0]	Global Interrupt Mask bit When this bit is written a '1', it will allow interruption to the host. If it is written with a '0', then, it disables all interruption to the host. Writing to this bit does not affect the IER value.
1	IC[1]	Output Interrupt Type '0' = Level interrupt '1' = Edge interrupt
2	IC[2]	Output Interrupt Polarity '0' = Active Low / Falling Edge '1' = Active High / Rising Edge

9.3 Interrupt Enable Mask Register (IER)

IER register is used to enable the interruption from a particular interrupt source to the host.

	IER_msb								IER_lsb								
Bit	15	14	13	12	11	10	9	8	7	6	5	4	3	2	1	0	
	Reserved								IE8	IE7	IE6	IE5	IE4	IE3	IE2	IE1	IE0
R/W	R	R	R	R	R	R	R	RW	RW	RW	RW	RW	RW	RW	RW	RW	
Reset Value	0	0	0	0	0	0	0	0	0	0	0	0	0	0	0	0	

Table 25. Register description

Bits	Name	Description
8:0	IE[x]	Interrupt Enable Mask (where x = 8 to 0) IE0 = Wake-up Interrupt Mask IE1 = Keypad Controller Interrupt Mask IE2 = Keypad Controller FIFO Overflow Interrupt Mask IE3 = Rotator Controller Interrupt Mask IE4 = Rotator Controller Buffer Overflow Interrupt Mask IE5 = PWM Channel 0 Interrupt Mask IE6 = PWM Channel 1 Interrupt Mask IE7 = PWM Channel 2 Interrupt Mask IE8 = GPIO Controller Interrupt Mask Writing a '1' to the IE[x] bit will enable the interruption to the host.

9.4 Interrupt Status Register (ISR)

ISR register monitors the status of the interruption from a particular interrupt source to the host. Regardless whether the IER bits are enabled or not, the ISR bits are still updated.

	ISR_msb								ISR_lsb								
Bit	15	14	13	12	11	10	9	8	7	6	5	4	3	2	1	0	
	Reserved								IS8	IS7	IS6	IS5	IS4	IS3	IS2	IS1	IS0
R/W	R	R	R	R	R	R	R	RW	RW	RW	RW	RW	RW	RW	RW	RW	
Reset Value	0	0	0	0	0	0	0	0	0	0	0	0	0	0	0	0	

Table 26. Register description

Bits	Name	Description
8:0	IS[x]	Interrupt Status (where x = 8 to 0) Read: IS0 = Wake-up Interrupt Status IS1 = Keypad Controller Interrupt Status IS2 = Keypad Controller FIFO Overflow Interrupt Status IS3 = Rotator Controller Interrupt Status IS4 = Rotator Controller Buffer Overflow Interrupt Status IS5 = PWM Channel 0 Interrupt Status IS6 = PWM Channel 1 Interrupt Status IS7 = PWM Channel 2 Interrupt Status IS8 = GPIO Controller Interrupt Status Write: A write to a IS[x] bit with a value of '1' will clear the interrupt and a write with a value of '0' has no effect on the IS[x] bit.

9.5 Interrupt Enable GPIO Mask Register (IEGPIOR)

IEGPIOR register is used to enable the interruption from a particular GPIO interrupt source to the host. The IEG[23:0] bits are the interrupt enable mask bits correspond to the GPIO[23:0] pins.

Table 27. IEGPIOR register

Bit	7	6	5	4	3	2	1	0
IEGPIOR_msb	IEG -23	IEG -22	IEG -21	IEG -20	IEG -19	IEG -18	IEG -17	IEG -16
IEGPIOR_csb	IEG -15	IEG -14	IEG -13	IEG -12	IEG -11	IEG -10	IEG -9	IEG -8
IEGPIOR_lsb	IEG -7	IEG -6	IEG -5	IEG -4	IEG -3	IEG -2	IEG -1	IEG -0

Table 28. Register description

Name	Description
IEG[x]	Interrupt Enable GPIO Mask (where x = 23 to 0) Writing a '1' to the IE[x] bit will enable the interruption to the host.

9.6 Interrupt Status GPIO Register (ISGPIOR)

ISGPIOR register monitors the status of the interruption from a particular GPIO pin interrupt source to the host. Regardless whether the IEGPIOR bits are enabled or not, the ISGPIOR bits are still updated. The ISG[23:0] bits are the interrupt status bits correspond to the GPIO[23:0] pins.

Table 29. ISGPIOR register

Bit	7	6	5	4	3	2	1	0
ISGPIOR_msb	ISG-23	ISG -22	ISG -21	ISG -20	ISG -19	ISG -18	ISG -17	ISG -16
ISGPIOR_csb	ISG -15	ISG -14	ISG -13	ISG -12	ISG -11	ISG -10	ISG -9	ISG -8
ISGPIOR_lsb	ISG -7	ISG -6	ISG -5	ISG -4	ISG -3	ISG -2	ISG -1	ISG -0

Table 30. Register description

Name	Description
ISG[x]	Interrupt Status GPIO (where x = 23 to 0) Read: Interrupt Status of the GPIO[x]. Write: A write to a ISG[x] bit with a value of '1' will clear the interrupt and a write with a value of '0' has no effect on the ISG[x] bit.

9.7 Programming sequence

To configure and initialize the Interrupt Controller to allow interruption to host, observe the following steps:

- Set the IER and IEGPIOR registers to the desired values to enable the interrupt sources that are to be expected to receive from.
- Configure the output interrupt type and polarity and enable the global interrupt mask by writing to the ICR.
- Wait for interrupt.
- Upon receiving an interrupt, the INT pin is asserted.
- The host comes to read the ISR through I2C interface. A '1' in the ISR bits indicates that the corresponding interrupt source is triggered.
- If the IS8 bit in ISR is set, the interrupt is coming from the GPIO Controller. Then, a subsequent read is performed on the ISGPIOR to obtain the interrupt status of all 24 GPIOs to locate the GPIO that triggers the interrupt. This is a feature so-called 'Hot Key'.
- After obtaining the interrupt source that triggers the interrupt, the host performs the necessary processing and operations related to the interrupt source.
- If the interrupt source is from the GPIO Controller, two write operations with value of '1' are performed to the ISG[x] bit (ISGPIOR) and the IS[8] (ISR) to clear the corresponding GPIO interrupt.
- If the interrupt source is from other module, a write operation with value of '1' is performed to the IS[x] (ISR) to clear the corresponding interrupt.
- Once the interrupt is being cleared, the INT pin will also be de-asserted if the interrupt type is level interrupt. An edge interrupt will only assert a pulse width of 250ns.
- When the interrupt is no longer required, the IC0 bit in ICR may be set to '0' to disable the global interrupt mask bit.

10 GPIO controller

A total of 24 GPIOs are available in the STMPE2403 port expander IC. Most of the GPIOs are sharing physical pins with some alternate functions. The GPIO controller contains the registers that allow the host system to configure each of the pins into either a GPIO, or one of the alternate functions. Unused GPIOs should be configured as outputs to minimize the power consumption.

Table 31. GPIO controller

Address	Register Name	Description	Auto-Increment (during sequential R/W)
0xA2	GPMR_msb	GPIO Monitor Pin State Register	Yes
0xA3	GPMR_csb		Yes
0xA4	GPMR_lsb		Yes
0x83	GPSR_msb	GPIO Set Pin State Register	Yes
0x84	GPSR_csb		Yes
0x85	GPSR_lsb		Yes
0x86	GPCR_msb	GPIO Clear Pin State Register	Yes
0x87	GPCR_csb		Yes
0x88	GPCR_lsb		Yes
0x89	GPDR_msb	GPIO Set Pin Direction Register	Yes
0x8A	GPDR_csb		Yes
0x8B	GPDR_lsb		Yes
0x8C	GPEDR_msb	GPIO Edge Detect Status Register	Yes
0x8D	GPEDR_csb		Yes
0x8E	GPEDR_lsb		Yes
0x8F	GPRER_msb	GPIO Rising Edge Register	Yes
0x90	GPRER_csb		Yes
0x91	GPRER_lsb		Yes
0x92	GPFER_msb	GPIO Falling Edge Register	Yes
0x93	GPFER_csb		Yes
0x94	GPFER_lsb		Yes
0x95	GPPUR_msb	GPIO Pull Up Register	Yes
0x96	GPPUR_csb		Yes
0x97	GPPUR_lsb		Yes
0x98	GPPDR_msb	GPIO Pull Down Register	Yes
0x99	GPPDR_csb		Yes
0x9A	GPPDR_lsb		Yes

Table 31. GPIO controller (continued)

Address	Register Name	Description	Auto-Increment (during sequential R/W)
0x9B	GPAFR_U_msb	GPIO Alternate Function Register (Upper Bit)	Yes
0x9C	GPAFR_U_csb		Yes
0x9D	GPAFR_U_lsb		Yes
0x9E	GPAFR_L_msb	GPIO Alternate Function Register (Lower Bit)	Yes
0x9F	GPAFR_L_csb		Yes
0xA0	GPAFR_L_lsb		Yes
0xA1	MUX_CTRL	MUX Control Register	Yes
0xA5	COMPAT2401	STMPE2401 Pin Compatibility Register	Yes
0xA6 – 0xAF	RESERVED	Reserved	Yes

10.1 GPIO control registers

A group of registers are used to control the exact function of each of the 24 GPIO. All GPIO registers are named as GPxxx_yyy, where

Xxx represents the functional group

Yyy represents the byte position of the GPIO

Lsb registers controls GPIO[7:0]

Csb registers controls GPIO[15:8]

Msb registers controls GPIO[23:16]

Table 32. GPIO control registers

Bit	7	6	5	4	3	2	1	0
GPxxx_msb	IO-23	IO-22	IO-21	IO-20	IO-19	IO-18	IO-17	IO-16
GPxxx_csb	IO-15	IO-14	IO-13	IO-12	IO-11	IO-10	IO-9	IO-8
GPxxx_lsb	IO-7	IO-6	IO-5	IO-4	IO-3	IO-2	IO-1	IO-0

Note: This convention does not apply to the GPIO Alternate Function Registers

The function of each bit is shown in the following table:

Table 33. Bit function

Register Name	Function
GPIO Monitor Pin State	Reading this bit yields the current state of the bit. Writing has no effect.
GPIO Set Pin State	Writing '1' to this bit causes the corresponding GPIO to go to '1' state. Writing '0' has no effect.
GPIO Clear Pin State	Writing '1' to this bit causes the corresponding GPIO to go to '0' state. Writing '0' has no effect.
GPIO Set Pin Direction	'0' sets the corresponding GPIO to input state, and '1' sets it to output state
GPIO Edge Detect Status	Set to '1' by hardware when there is a rising/falling edge on the corresponding GPIO. Writing '1' clears the bit. Writing '0' has no effect.
GPIO Rising Edge	Set to '1' to enable rising edge detection on the corresponding GPIO.
GPIO Falling Edge	Set to '1' to enable falling edge detection on the corresponding GPIO.
GPIO Pull Up	Set to '1' to enable internal pull-up resistor
GPIO Pull Down	Set to '1' to enable internal pull-down resistor

10.2 GPIO Alternate Function Register (GPAFR)

GPAFR is to select the functionality of the GPIO pin. To select a function for a GPIO pin, a bit-pair in the register (GPAFR_U or GPAFR_L) has to be set.

		GPAFR_U_msb							
Bit		23	22	21	20	19	18	17	16
		AF23		AF22		AF21		AF20	
R/W		RW	RW	RW	RW	RW	RW	RW	RW
Reset Value		0	0	0	0	0	0	0	0
		GPAFR_U_csb							
Bit		15	14	13	12	11	10	9	8
		AF19		AF18		AF17		AF16	
R/W		RW	RW	RW	RW	RW	RW	RW	RW
Reset Value		0	0	0	0	0	0	0	0
		GPAFR_U_lsb							
Bit		7	6	5	4	3	2	1	0
		AF15		AF14		AF13		AF12	
R/W		RW	RW	RW	RW	RW	RW	RW	RW
Reset Value		0	0	0	0	0	0	0	0

Table 34. Bit description

Bits	Name	Description
23:0	AF[x]	GPIO Pin 'x' Alternate Function Select (where x = 23 to 12). '00' – The corresponding GPIO pin (GPIO[x]) is configured to Primary Function. '01' – The corresponding GPIO pin (GPIO[x]) is configured to Alternate Function 1. '10' – The corresponding GPIO pin (GPIO[x]) is configured to Alternate Function 2. '11' – The corresponding GPIO pin (GPIO[x]) is configured to Alternate Function 3.

		GPAFR_L_msb							
Bit		23	22	21	20	19	18	17	16
		AF11		AF10		AF9		AF8	
R/W		RW	RW	RW	RW	RW	RW	RW	RW
Reset Value		0	0	0	0	0	0	0	0
		GPAFR_L_csb							
Bit		15	14	13	12	11	10	9	8
		AF7		AF6		AF5		AF4	
R/W		RW	RW	RW	RW	RW	RW	RW	RW
Reset Value		0	0	0	0	0	0	0	0
		GPAFR_L_lsb							
Bit		7	6	5	4	3	2	1	0
		AF3		AF2		AF1		AF0	
R/W		RW	RW	RW	RW	RW	RW	RW	RW
Reset Value		0	0	0	0	0	0	0	0

Table 35. Bit description

Bits	Name	Description
23:0	AF[x]	GPIO Pin 'x' Alternate Function Select (where x = 11 to 0). '00' – The corresponding GPIO pin (GPIO[x]) is configured to Primary Function. '01' – The corresponding GPIO pin (GPIO[x]) is configured to Alternate Function 1. '10' – The corresponding GPIO pin (GPIO[x]) is configured to Alternate Function 2. '11' – The corresponding GPIO pin (GPIO[x]) is configured to Alternate Function 3.

10.3 Hot key feature

A GPIO is known as 'Hot Key' when it is configured to trigger an interruption to the host whenever the GPIO input is being asserted. This feature is applicable in Operational mode, as well as Sleep mode.

10.3.1 Programming sequence for Hot Key

1. Configures the GPIO pin into GPIO mode by setting the corresponding bits in the GPAFR.
2. Configures the GPIO pin into input direction by setting the corresponding bit in GPDR.
3. Set the GPRER and GPFER to the desired values to enable the rising edge or falling edge detection.
4. Configures and enables the interrupt controller to allow the interruption to the host.
5. Now, the GPIO Expander may be put into Sleep mode if it is desired.
6. Upon any Hot Key being asserted, the device will wake-up and issue an interrupt to the host.

Below are the conditions to be fulfilled in order to configure a Hot Key:

1. The pin is configured into GPIO mode and as input pin.
2. The global interrupt mask bit is enabled.
3. The corresponding GPIO interrupt mask bit is enabled.

10.3.2 Minimum pulse width

The minimum pulse width of the assertion of the Hot Key must be at least 62.5us. Any pulse width less than the stated value may not be registered.

10.4 MUX Control Register (MCR)

STMPE2403 is integrated with 2 SPDT bi-directional signal multiplexer. The Ron of the multiplexer is 5 OHM (Typical). Signal level is 1.8V (MAX). The MUX are controlled by the MUX Control register.

MCR is to control the two analog multiplexers operation.

MCR								
Bit	7	6	5	4	3	2	1	0
	RESERVED				M1C1	M2C1	M1C1	M1C0
R/W	R	R	R	R	RW	RW	RW	RW
Reset Value	0	0	0	0	0	0	0	0

Table 36. Bit description

Bits	Name	Description
0	M1C0	MUX 1 Control 0 bit selects whether Mux1In_0 or Mux1In_1 connects to Mux1Out. '0' – Mux1In_0 is connected to the Mux1Out. '1' – Mux1In_1 is connected to the Mux1Out.
1	M1C1	MUX 1 Control 1 bit enables the MUX 1. '0' – Enables the MUX 1. '1' – Disables the MUX 1.
2	M2C0	MUX 2 Control 0 bit selects whether Mux2In_0 or Mux2In_1 connects to Mux2Out. '0' – Mux1In_0 is connected to the Mux1Out. '1' – Mux1In_1 is connected to the Mux1Out.
3	M2C1	MUX 2 Control 1 bit enables the MUX 2. '0' – Enables the MUX 2. '1' – Disables the MUX 2.

10.5 STMPE2401 Pin Compatibility Register (COMPAT2401)

STMPE2403 is an enhanced version of the other port expander device, STMPE2401. However, the pin configuration of STMPE2403 is different from that of STMPE2401. For backward pin compatibility to STMPE2401, COMPAT2401 register provides a control bit that allows STMPEE2403 to have the same pin configuration as in STMPE2401.

		COMPAT2401							
Bit		7	6	5	4	3	2	1	0
		RESERVED							PIN2401
R/W		R	R	R	R	R	R	R	RW
Reset Value		0	0	0	0	0	0	0	0

Table 37. Bit description

Bits	Name	Description
0	PIN2401	This control bit selects pin configuration to be used. '0' – STMPE2401 pin configuration as defined in sections 1.1 and 1.3. '1' – Pin configuration compatible to STMPE2401.

The pin locations for the following eight IO ports are different from those shown in section 1.3: KP_X0, KP_X1, KP_X2, KP_X3, KP_Y4, KP_Y5, KP_Y6 and KP_Y7. When 'PIN2401' bit is set to '1', the eight IO ports are assigned to the pin locations as defined by the following diagram.

Table 38. Pin location

	A	B	C	D	E	F
1	KP_X2	KP_X1	RESET	XTALOUT	SCLK	KP_Y6
2	KP_X4	KP_X3	KP_X0	XTALIN	SDATA	KP_Y7
3	KP_X6	KP_X5	GND1	GND2	KP_Y8	INT
4	VCC1	KP_X7	GND3	GND4	PWM-1	VCC2
5	KP_Y5	KP_Y3	KP_Y1	KP_Y9	PWM-3	PWM-2
6	KP_Y4	KP_Y2	KP_Y0	ADDR0	KP_Y10	KP_Y11

11 PWM controller

The STMPE2403 PWM controller provides 3 independent PWM outputs used to generate light effect; if the PWM outputs are not used, these pins can be used as GPIO.

Figure 7. PWM controller

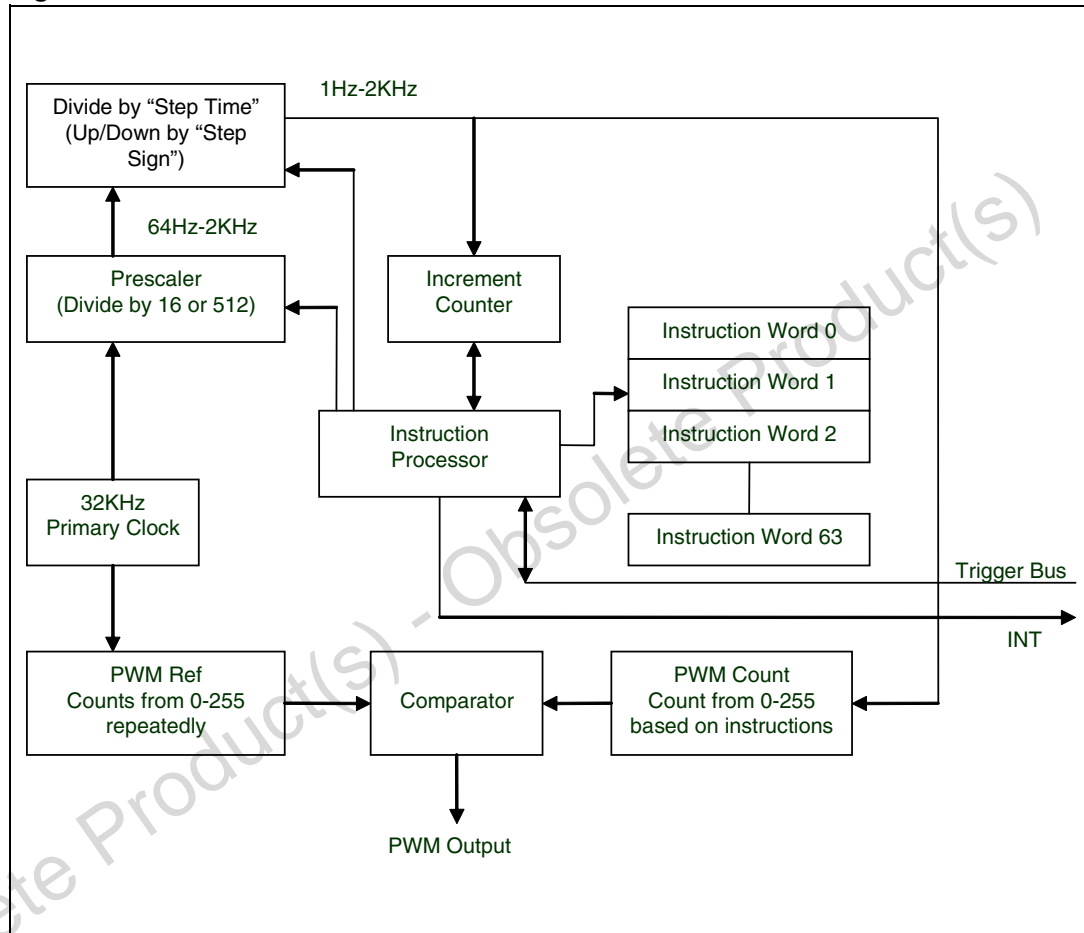

Instructions are downloaded into the memory via the I2C connection.

11.1 Registers in the PWM controller

The main system registers are:

Table 39. Main system registers

Address	Register name	Description	Auto-Increment (during Read/Write)
0x30	PWMCS	PWM Control and Status register	Yes
0x38	PWMIC0	PWM instructions are initialized through this data port. Every instruction is 16-bit width and therefore, the MSB of the first word is written first, then, followed by LSB of the first word. Subsequently, MSB of second word and LSB of second word and so on.	No
0x39	PWMIC1	PWM instructions are initialized through this data port. Every instruction is 16-bit width and therefore, the MSB of the first word is written first, then, followed by LSB of the first word. Subsequently, MSB of second word and LSB of second word and so on.	No
0x3A	PWMIC2	PWM instructions are initialized through this data port. Every instruction is 16-bit width and therefore, the MSB of the first word is written first, then, followed by LSB of the first word. Subsequently, MSB of second word and LSB of second word and so on.	No

11.2 PWM Control and Status Register (PWMCS)

Bit	7	6	5	4	3	2	1	0
	ExtSel	ExtEn	II2	II1	II0	EN2	EN1	EN0
Read/Write	RW	RW	R	R	R	RW	RW	RW
Reset Value	0	0	0	0	0	0	0	0

Table 40. Bit description

Bits	Name	Description
0	EN0	PWM Channel 0 Enable bit. '1' – Enable the PWM Channel 0 '0' – Reset the PWM Channel 0. Only when the PWM channel is in reset state, the stream of commands can be written into its data port, which in this case is PWM_Command_Channel_0.
1	EN1	PWM Channel 1 Enable bit. '1' – Enable the PWM Channel 1 '0' – Reset the PWM Channel 1. Only when the PWM channel is in reset state, the stream of commands can be written into its data port, which in this case is PWM_Command_Channel_1.
2	EN2	PWM Channel 2 Enable bit. '1' – Enable the PWM Channel 2 '0' – Reset the PWM Channel 2. Only when the PWM channel is in reset state, the stream of commands can be written into its data port, which in this case is PWM_Command_Channel_2.
3	II0	PWM Invalid Instruction Status bit for PWM Channel 0 '0' – No invalid command encountered during the instruction execution. '1' – Invalid command encountered and this puts the PWM Channel 0 into reset state.
4	II1	PWM Invalid Instruction Status bit for PWM Channel 1 '0' – No invalid command encountered during the instruction execution. '1' – Invalid command encountered and this puts the PWM Channel 1 into reset state.
5	II2	PWM Invalid Instruction Status bit for PWM Channel 2 '0' – No invalid command encountered during the instruction execution. '1' – Invalid command encountered and this puts the PWM Channel 2 into reset state.
6	ExtEn	External Trigger Enable '0' – External triggering function is disabled '1' – External triggering function is enabled If enabled, GPIO-15 is used as trigger input/output
7	ExtSel	External Trigger Direction Selection '0' – Active high external trigger input '1' – Active low external trigger output

11.3 PWM Instruction Channel x (PWMICx)

This PWMICx is the dataport that allows the instructions to be loaded into the PWM channel. The loading of the instructions is achieved by continuously writing to this dataport. As this dataport address falls on the non-auto increment region, continuous write operation on I²C will write into the same dataport address. The 'x' value is from 0 to 2 as there are 3 independent PWM channels. To access these dataports, the corresponding ENx in the PWMCS register must be set to 0 first to put the PWM channel in reset state.

Bit	7	6	5	4	3	2	1	0
	IB7	IB6	IB5	IB4	IB3	IB2	IB1	IB0
Read/Write	RW	RW	RW	RW	RW	RW	RW	RW
Reset Value	0	0	0	0	0	0	0	0

Table 41. Bit description

Bits	Name	Description
7:0	IB[y]	PWM Instruction Channel x, where y is 7 to 0 As an instruction is 16-bit width, writing the instruction into this 8-bit PWMICx dataport requires two 8-bit data write. The most significant byte of the 16-bit instruction is to be written in first and followed by the least significant byte of the instruction. The same effect applies to the read operation.

11.4 PWM commands

The STMPE2403 PWM Controller works as a simple MCU, with program space of 64 instructions and a simple instruction set. The instructions are all 16 bits in length. The 3 most significant bits are used to identify the commands.

Table 42. PWM commands

Instruction	Description
RAMP	This instruction starts the PWM counters and set the pwm_x_out with the result from the counting. Prescale: (0 or 1) '0' - divide 32KHz clock by 16 '1' - divide 32KHz clock by 512 Step Time: (1-63) One ramp increment done in (step time) x (clock after prescale) Sign: (0 or 1) "0" - increase PWM output '1' - decrease PWM output Increment: (0-127) The number of increment/decrement cycles

Table 42. PWM commands (continued)

Instruction	Description
LOAD	Load the PWM counter with a value between 0x0 and 0xFF. PWM value: (0-255) Loads an absolute value between 0-255 into PWM count
Go to Start (GTS)	Branch to the address 0x0 and execute from 0x0 and onwards.
BRANCH	This instruction loads the Step Number into the instruction counter Loop Count: (0-63) Number of loops to repeat. 0 means infinite loop Addr: (0 or 1) 0 – Absolute addressing 1 – Relative addressing Step Size: (0-63) The step number to be loaded to instruction counter
END	End the instruction execution by resetting and interrupting to the host.
Trigger (TRIG)	Capable of waiting as well as sending triggers to another PWM channel. Can be configured to send/receive external trigger Wait For Trigger Bit 7: Channel 0 Bit 8: Channel 1 Bit 9: Channel 2 Bit 12: External Trigger Input Send Trigger Bit 1: Channel 0 Bit 2: Channel 1 Bit 3: Channel 2 Bit 6: External Trigger Output

Table 43. Identification of Instructions

Instruction	Bit 15	Bit 14	Bit 13
Ramp	0	-	-
LOAD	0	1	-
GoToStart	0	0	-
Branch	1	0	1
End	1	1	0
Trigger	1	1	1
Reserved	1	0	0

Table 44. Instruction bit

Instruction	Bit																
	15	14	13	12	11	10	9	8	7	6	5	4	3	2	1	0	
RAMP	0	Prescale 0=16 1=512	Step Time 0 - 63 0 = immediate action					Sign 0=step-up 1=step-down		Increment 1 – 126							
LOAD	0	1	0					PWM Value 0-255									
GTS	0	0	0					0		0							
BRANCH	1	01		Loop Count 0-63						Addr	Step Size 0 – 63*						
END	1	10		Interrupt to host	Reset instruction counter and output level to zero	RESERVED											
TRIG	1	11		Wait for Trigger on channel 0 – 2 and external Trigger. Continues if all selected triggers present. Each bit signifies wait for the corresponding channel.						Send Trigger on channel 0 – 2 and external Trigger. Continues if no Wait for Trigger in this instruction.						x ⁽¹⁾	
reserved	1	00		RESERVED													

1. Don't care

In order to enable a PWM channel, the programming sequence below should be observed.

- The ENx of the PWMCS register should be kept in '0'. By default, it has a value of '0'.
- Loads the instructions into the PWM channel x by writing the corresponding PWMICx.
- The PWM channel x has a 64-word depth (16-bit width). Any instructions of size less than or equal to 64 words can be loaded into the channel. Any attempt to load beyond 64 words will result in internal address pointer to roll-over (0x1f \diamond 0x00) and the excess instructions to be over-written into the first address location of the channel and onwards.
- After the instructions are loaded in, then, the PWM channel x can be enabled by setting a '1' to the ENx bit.
- Enables the corresponding interrupt mask bit to allow interruption to the host.

12 Keypad controller

The keypad controller consists of: 1) four dedicated key controllers that support up to four simultaneous dedicated key presses; 2) a key scan controller and two normal key controllers that support a maximum of 12x8 key matrix with detection of three simultaneous key presses; 3) eight special function key controllers that support up to eight simultaneous special function key presses.

Four of the column inputs can be configured as dedicated keys through the setting of Dkey0~3 bits of KPC_ctrl register.

The normal key matrix size is configurable through the setting of KPC_row and KPC_col registers. The scanning of each individual row output and column input can be enabled or masked to support a key matrix of variable size from 1x1 to 12x8. It is allowed to have another eight special function keys incorporated in the key matrix.

The operation of the keypad controller is enabled by the SCAN bit of KPC_ctrl register. Every key activity detected will be de-bounced for a period set by the DB_0~7 bits of KPC_ctrl register before a key press or key release is confirmed and updated into the output FIFO. The key data, indicating the key coordinates and its status (up or down), is loaded into the FIFO at the end of a specified number of scanning cycles (set by ScanCount0~3 bits of KPC_row_msb register). An interrupt will be generated when a new set of key data is loaded. The FIFO has a capacity for ten sets of key data. Each set of key data consists of 5 bytes of information when any of the four dedicated keys is enabled. It is reduced to 4 bytes when no dedicated key is involved. When the FIFO is full before its content is read, an overflow signal will be generated while the FIFO will continue to hold its content but forbid loading of new key data set.

Figure 8. Keypad controller

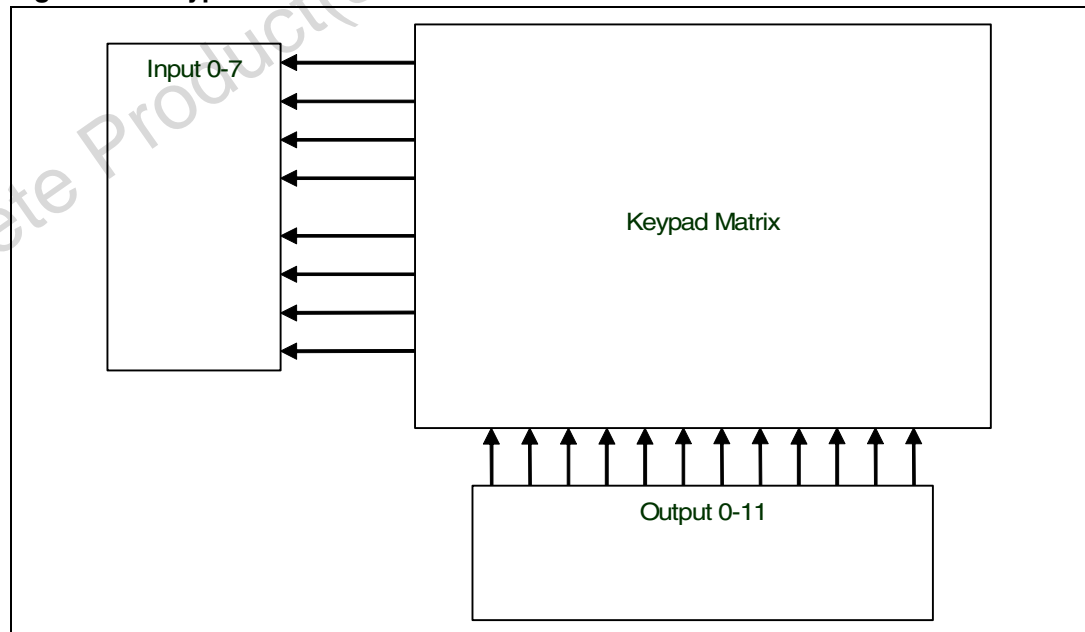

The keypad column inputs enabled by the KPC_col register are normally 'HIGH', with the corresponding input pins pulled up by resistors internally. After reset, all the keypad row outputs enabled by the KPC_row register are driven 'LOW'. If a key is pressed, its corresponding column input will become 'LOW' after making contact with the 'LOW' voltage on its corresponding row output.

Once the key scan controller senses a 'LOW' input on any of the column inputs, the scanning cycles will then start to determine the exact key that has been pressed. The twelve row outputs will be driven 'LOW' one by one during each scanning cycle. While one row is driven 'LOW', all other rows are in tri-state and pulled up. If there is any column input sensed as 'LOW' when a row is driven 'LOW', the key scan controller will then decode the key coordinates (its corresponding row number and column number), save the key data into a de-bounce buffer if available, confirm if it is a valid key press after de-bouncing, and update the key data into output data FIFO if valid.

12.1 Keypad configurations

The keypad controller supports the following types of keys

- Up to 8 Input *12 Output Matrix Keys
- Up to 8 Special Function Keys
- Up to 4 Dedicated Keys

Figure 9. Maximum configuration

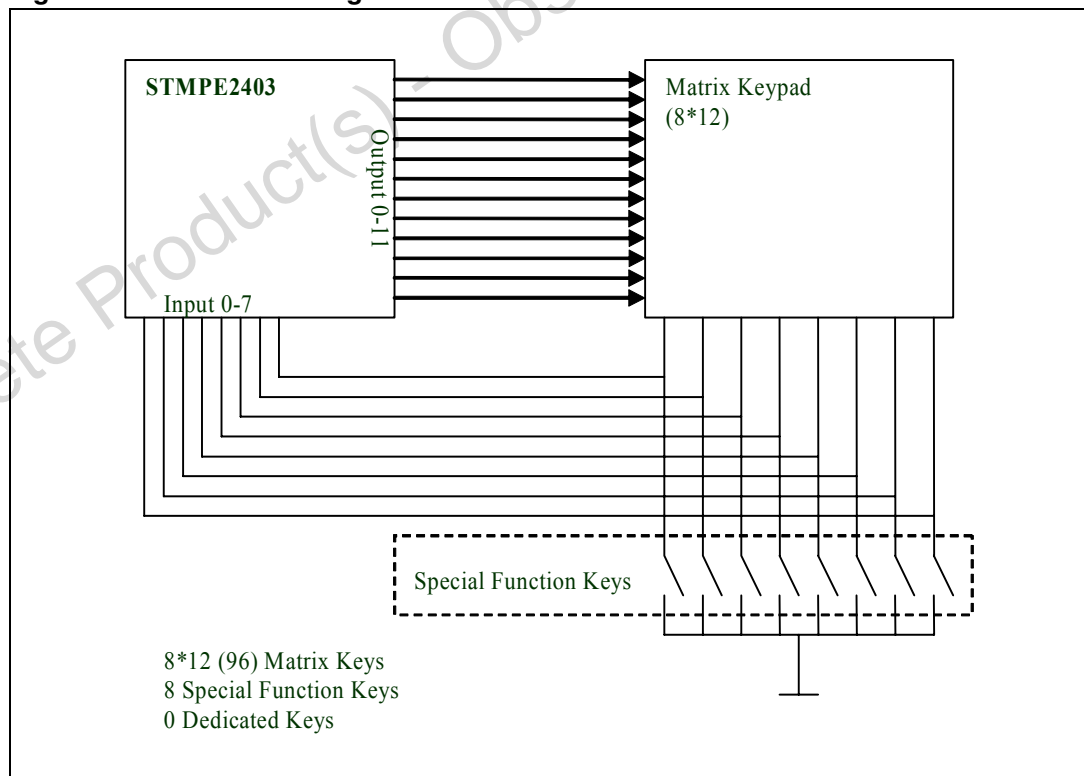
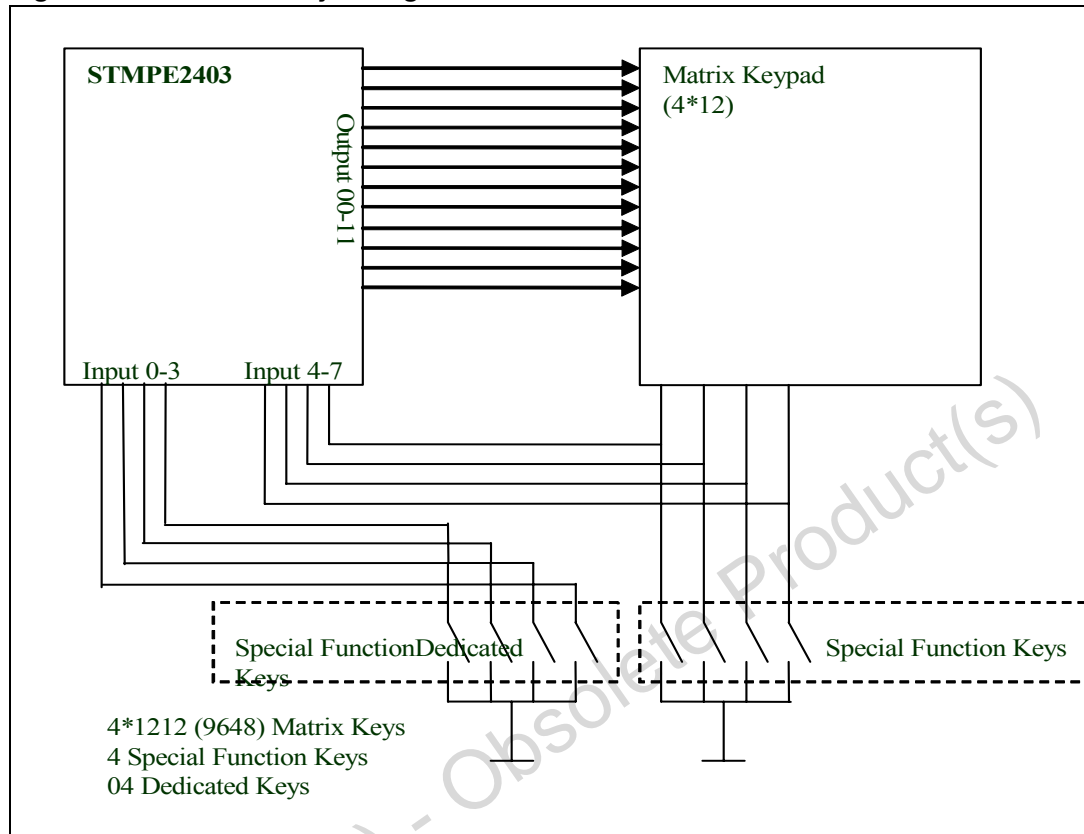

Figure 10. Dedicated key configuration



12.2 Registers in keypad controller

Table 45. Registers in keypad controller

Address	Register Name	Description	Auto-Increment (during sequential R/W)
0x60	KPC_col	Keypad column scanning register	Yes
0x61	KPC_row_msb	Keypad row scanning register	Yes
0x62	KPC_row_lsb		Yes
0x63	KPC_ctrl_msb	Keypad control register	Yes
0x64	KPC_ctrl_lsb		Yes
0x68	KPC_data_byte0	Keypad data register	Yes
0x69	KPC_data_byte1		Yes
0x6A	KPC_data_byte2		Yes
0x6B	KPC_data_byte3		Yes
0x6C	KPC_data_byte4		Yes

12.3 KPC_col register

Bit	7	6	5	4	3	2	1	0
Name	Input Column 0 ~ 7							
Read/Write	RW	RW	RW	RW	RW	RW	RW	RW
Reset Value	0	0	0	0	0	0	0	0

Table 46. Bit description

Bit	Name	Description
7	Input Column 7	'1' to turn on scanning of column 7; '0' to turn off
6	Input Column 6	'1' to turn on scanning of column 6; '0' to turn off
5	Input Column 5	'1' to turn on scanning of column 5; '0' to turn off
4	Input Column 4	'1' to turn on scanning of column 4; '0' to turn off
3	Input Column 3	'1' to turn on scanning of column 3; '0' to turn off
2	Input Column 2	'1' to turn on scanning of column 2; '0' to turn off
1	Input Column 1	'1' to turn on scanning of column 1; '0' to turn off
0	Input Column 0	'1' to turn on scanning of column 0; '0' to turn off

12.4 KPC_row_msb register

Bit	7	6	5	4	3	2	1	0
Name	ScanPW1	ScanPW0	Hib_Wk	-	Output Row 8 ~ 11			
Read/Write	RW	RW	RW	R	RW	RW	RW	RW
Reset Value	1	1	0	0	0	0	0	0

Table 47. Bit description

Bit	Name	Description
7	ScanPW1	Pulse width setting of keypad scanning. Use "11" at all times
6	ScanPW0	
5	Hib_Wk	'1' to enable keypad wake-up from hibernate mode; '0' to disable
4	-	-
3	Output Row 11	'1' to turn on scanning of row 11; '0' to turn off
2	Output Row 10	'1' to turn on scanning of row 10; '0' to turn off
1	Output Row 9	'1' to turn on scanning of row 9; '0' to turn off
0	Output Row 8	'1' to turn on scanning of row 8; '0' to turn off

12.5 KPC_row_lsb register

Bit	7	6	5	4	3	2	1	0
Name	Output Row 0 ~ 7							
Read/Write	RW	RW	RW	RW	RW	RW	RW	RW
Reset Value	0	0	0	0	0	0	0	0

Table 48. Bit description

Bit	Name	Description
7	Output Row 7	'1' to turn on scanning of row 7; '0' to turn off
6	Output Row 6	'1' to turn on scanning of row 6; '0' to turn off
5	Output Row 5	'1' to turn on scanning of row 5; '0' to turn off
4	Output Row 4	'1' to turn on scanning of row 4; '0' to turn off
3	Output Row 3	'1' to turn on scanning of row 3; '0' to turn off
2	Output Row 2	'1' to turn on scanning of row 2; '0' to turn off
1	Output Row 1	'1' to turn on scanning of row 1; '0' to turn off
0	Output Row 0	'1' to turn on scanning of row 0; '0' to turn off

12.6 KPC_ctrl_msb register

Bit	7	6	5	4	3	2	1	0
Name	ScanCount0 ~ 3				DKey_0 ~ 3			
Read/Write	RW	RW	RW	RW	RW	RW	RW	RW
Reset Value	0	0	0	0	0	0	0	0

Table 49. Bit description

Bit	Name	Description
7	ScanCount3	Number of key scanning cycles elapsed before a confirmed key data is updated into output data FIFO (0 ~ 15 cycles)
6	ScanCount2	
5	ScanCount1	
4	ScanCount0	
3	DKey_3	Set '1' to use Input Column 3 as dedicated key
2	DKey_2	Set '1' to use Input Column 2 as dedicated key
1	DKey_1	Set '1' to use Input Column 1 as dedicated key
0	DKey_0	Set '1' to use Input Column 0 as dedicated key

12.7 KPC_ctrl_Isb register

Bit	7	6	5	4	3	2	1	0
Name	DB_0 ~ 5							SCAN
Read/Write	RW	RW	RW	RW	RW	RW	RW	RW
Reset Value	0	0	0	0	0	0	0	0

Table 50. Bit description

Bit	Name	Description
7	DB_6	0-128ms of de-bounce time
6	DB_5	
5	DB_4	
4	DB_3	
3	DB_2	
2	DB_1	
1	DB_0	
0	SCAN	'1' to start scanning; '0' to stop

12.8 Data registers

The KPC_DATA register contains three bytes of information. The first two bytes store the key coordinates and status of any two keys from the normal key matrix, while the third byte store the status of dedicated keys.

KPC_data_byte0 Register

Bit	7	6	5	4	3	2	1	0
Name	Up/Down	R3	R2	R1	R0	C2	C1	C0
Read/Write	R	R	R	R	R	R	R	R
Reset Value	1	1	1	1	1	0	0	0

Table 51. Bit description

Bit	Name	Description
7	Up/Down	'0' for key-down, '1' for key-up
6	R3	row number of key 1 (valid range : 0-11) 0x1111 for No Key
5	R2	
4	R1	
3	R0	
2	C2	column number of key 1 (valid range : 0-7)
1	C1	
0	C0	

KPC_data_byte1 Register

Bit	7	6	5	4	3	2	1	0
Name	Up/Down	R3	R2	R1	R0	C2	C1	C0
Read/Write	R	R	R	R	R	R	R	R
Reset Value	1	1	1	1	1	0	0	0

Table 52. Bit description

Bit	Name	Description
7	Up/Down	'0' for key-down, '1' for key-up
6	R3	row number of key 2 (valid range : 0-11) 0x1111 for No Key
5	R2	
4	R1	
3	R0	
2	C2	column number of key 2 (valid range : 0-7)
1	C1	
0	C0	

KPC_data_byte2 Register

Bit	7	6	5	4	3	2	1	0
Name	Up/Down	R3	R2	R1	R0	C2	C1	C0
Read/Write	R	R	R	R	R	R	R	R
Reset Value	1	1	1	1	1	0	0	0

Table 53. Bit description

Bit	Name	Description
7	Up/Down	'0' for key-down, '1' for key-up
6	R3	row number of key 3 (valid range : 0-11) 0x1111 for No Key
5	R2	
4	R1	
3	R0	
2	C2	column number of key 3 (valid range : 0-7)
1	C1	
0	C0	

KPC_data_byte3 Register

Bit	7	6	5	4	3	2	1	0
Name	SF7	SF6	SF5	SF4	SF3	SF2	SF1	SF0
Read/Write	R	R	R	R	R	R	R	R
Reset Value	1	1	1	1	1	1	1	1

Table 54. Bit description

Bit	Name	Description
7	SF7	'0' for key-down, '1' for key-up
6	SF6	'0' for key-down, '1' for key-up
5	SF5	'0' for key-down, '1' for key-up
4	SF4	'0' for key-down, '1' for key-up
3	SF3	'0' for key-down, '1' for key-up
2	SF2	'0' for key-down, '1' for key-up
1	SF1	'0' for key-down, '1' for key-up
0	SF0	'0' for key-down, '1' for key-up

KPC_data_byte4 Register

Bit	7	6	5	4	3	2	1	0
Name	-	-	-	-	Dedicated Key 0 ~ 3			
Read/Write	R	R	R	R	R	R	R	R
Reset Value	0	0	0	0	1	1	1	1

Table 55. Bit description

Bit	Name	Description
7	-	-
6	-	-
5	-	-
4	-	-
3	Dedicated Key 3	'0' for key-down, '1' for key-up
2	Dedicated Key 2	'0' for key-down, '1' for key-up
1	Dedicated Key 1	'0' for key-down, '1' for key-up
0	Dedicated Key 0	'0' for key-down, '1' for key-up

12.8.1 Resistance

Maximum resistance between keypad output and keypad input, inclusive of switch resistance, protection circuit resistance and connection, must be less than 3.2 K Ω

12.8.2 Using the keypad controller

It is not necessary to explicitly enable the internal pull-up and direction by configuring the GPIO control registers. Once a GPIO is enabled for keypad function, its internal pull-up and direction is controlled automatically.

The scanning of column inputs should then be enabled for those GPIO ports that are configured as keypad inputs by writing '1's to the corresponding bits in the KPC_col register. If any of the first three column inputs is to be used as dedicated key input, the corresponding bits in the KPC_ctrl_msb register should be set to '1'. The bits in the KPC_row_msb and KPC_row_lsb registers should also be set correctly to enable the row output scanning for the corresponding GPIO ports programmed as keypad outputs.

The scan count and de-bounce count should also be programmed into the keypad control registers before enabling the keypad controller operation. To enable the keypad controller operation, the Enable_KPC bit in the system control register must be set to '1' to provide the required clock signals. The keypad controller will then start its operation by setting the SCAN bit in the KPC_ctrl_lsb register to '1'.

The keypad controller operation can be disabled by setting the SCAN bit back to '0'. To further reduce the power consumption, the clock signals can be cut off from the keypad controller by setting the Enable_KPC bit to '0'.

As long as there is any un-read key-press in the keypad controller buffer, the KPC interrupt will always be asserted.

12.8.3 Ghost Key Handling

Ghost key is an inherent in keypad matrix that is not equipped with a diode at each of the keys. While it is not possible to avoid ghost key occurrence, the STMPE2403 allow the detection of possible ghost key by the capability of detecting 3 simultaneous key-presses in the key matrix.

Ghost key is only possible if 3 keys are pressed and held down together in a keypad matrix. If 3 keys are reported by STMPE2403 keypad controller, it indicates a potential ghost key situation. The system may check for possibility of ghost key by analyzing the coordinates of the 3 keys. If the 3 keys form 3 corners of a rectangle, it could be a ghost key situation.

Ghost key may also occur in the Special Function Keys. The keypad controller does not attempt to avoid the occurrence of ghost keys. However, the system should be aware that if more than one special function key is reported, then there is a possibility of ghost key.

12.8.4 Priority of Key detection

Dedicated key will always be detected, if it is enabled.

When a Special Function key is detected, the matrix key scanning on the same input line will be disabled.

Up to 3 matrix keys will be detected. Matrix keys that fall on activated Special Function keys will not be counted.

As a result of these rules of priority, a matrix key will be ignored by the keypad controller when the special function key on the same input line is detected, even if the matrix key is being pressed down before the special function key. Hence, when a matrix is reported “key-down” and it is being held down while the corresponding special function is being pressed, a “no-key” status will be reported for the matrix key when the special function key is reported “key-down”. If the matrix key is released while the special function key is still being held down, no “key-up” will be reported for the matrix key. On the other hand, if the matrix key is released after the special function key is reported “key-up”, then a new “key-down” will be reported for the matrix key, followed by “key-up”.

12.8.5 Keypad Wake-Up from sleep and hibernate modes

The keypad controller is functional in sleep mode as long as it is enabled before entering sleep mode. It will then wake the system up into operational mode if a valid key press is detected.

In the case of hibernate mode, the ‘Hib_Wk’ bit in ‘KPC_row_msb’ register must be set to ‘1’ in order to enable system wake-up by valid key press. When this is enabled, asynchronous detection of keypad column input activity will be turned on during hibernate mode. If any key activity is detected, the system is expected to enter sleep mode temporarily to allow de-bouncing of key press to take place. If a valid key is detected, the system will then wake up into operational mode; otherwise, the device will go back into hibernate mode.

13 Rotator controller

Rotator controller consists of 3 terminal, each capable of becoming an input with internal pull-up, or and output. At any moment, 2 terminals are inputs and one terminal is output.

Figure 11. Rotator controller

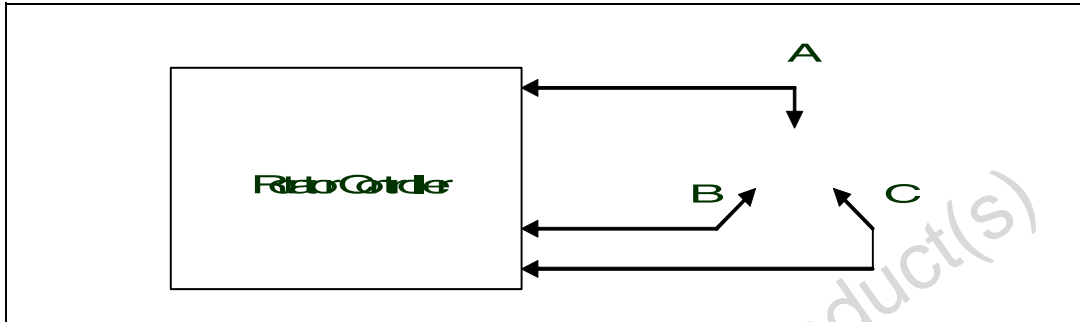

The Rotator Controller is responsible for the detection of the direction of rotator and the reporting of these direction sequences. The direction of a rotator can be either up or down. A rotator has 3 contacts and detection of shorts on these contacts is used to determine the direction of rotation. Following diagram shows the definition of the direction of rotation and how the FSM states and driven outputs correspond to rotation.

3 possible conditions: A-B short, B-C short, C-A short.

Table 56. Possible conditions

LO Input	Current State				Next State				Result
	State	Output	Input	Input	State	Output	Input	Input	
C	1	A	B	C	2	B	A	C	Up
B	1	A	B	C	3	C	A	B	Down
A	2	B	A	C	3	C	A	B	Down
C	2	B	A	C	1	A	B	C	Up
A	3	C	A	B	2	B	A	C	Up
B	3	C	A	B	1	A	B	C	Down

Figure 12. Rotator direction detection

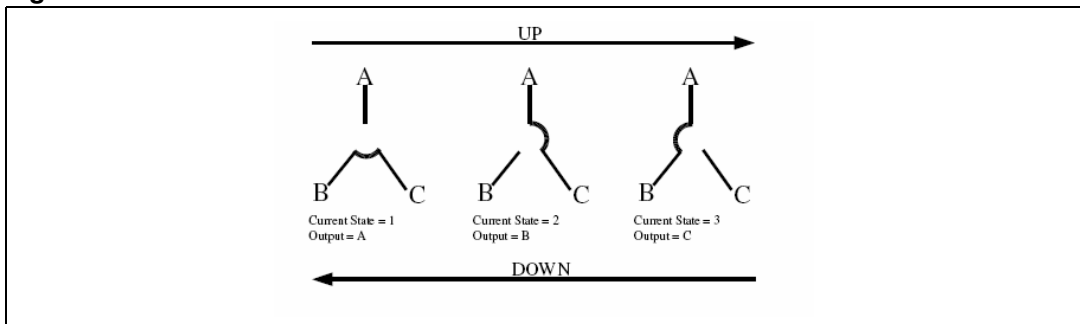

Figure 13. Registers for rotator control

Address	Register name	Register size
0x70	Rotator_Control	8
0x72	Rotator_Buffer	8

Rotator_Control

Bit	7	6	5	4	3	2	1	0
	Start_FSM	Reserved						
Read/Write	RW	R	R	R	R	R	R	R
Reset Value	0	0	0	0	0	0	0	0

Table 57. Bit description

Bits	Name	Description
7	Start_FSM	Rotator FSM start bit. '1' – Activate the FSM '0' – Stop sampling rotator symbols

Rotator_Buffer

Bit	7	6	5	4	3	2	1	0
	Symbol_Type	Symbol_Count						
Read/Write	R	R	R	R	R	R	R	R
Reset Value	0	0	0	0	0	0	0	0

Table 58. Bit description

Bits	Name	Description
7	Symbol_Type	Symbol type to be reported '1' – Down '0' – Up
6~0	Symbol_Count	Number of symbols of the type specified by bit 7 Minimum of 0 (b'0000000) to Maximum of 127 (b'1111111)

The host should do the following on the I2C bus to start the Rotator controller:

1. The host writes to GPIO Controller to select the Rotator Bits on the relevant IO.
2. Write Rotator_Control data register to start the rotator controller. A maximum of 2 rotations later, the correct initial state on the rotator FSM is obtained. Scanning for rotator movement continues.
3. The host waits for interrupt from the rotator controller.
4. The host reads Rotator_Buffer
5. The host can stop rotator controller operation by writing to Rotator_Control register.

14 Miscellaneous features

14.1 Reset

STMPE2403 is equipped with an internal POR circuit that holds the device in reset state, until the clock is steady and VCC input is valid. Host system may choose to reset the STMPE2403 by asserting Reset_N pin.

14.2 Under Voltage Lockout

STMPE2403 is equipped with an internal UVLO circuit that generates a RESET signal, when the main supply voltage falls below the allowed threshold.

14.3 Clock output

STMPE2403 provides a buffered 32KHz clock output at one of the GPIO as alternate function. This clock could be used for cascading of multiple port expander devices, using just 1 XTAL unit.

14.4 Crystal oscillator

STMPE2403 provides the option to use a crystal oscillator to provide the 32KHz clock.

Figure 14. Recommended schematics if external XTAL is used

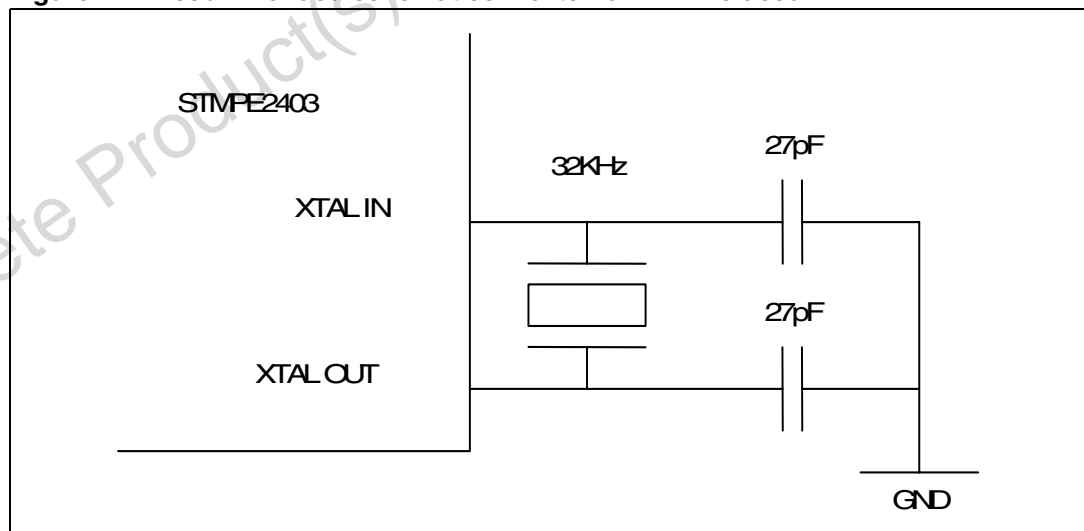

15 Package mechanical data

In order to meet environmental requirements, ST offers these devices in ECOPACK® packages. These packages have a Lead-free second level interconnect . The category of second level interconnect is marked on the package and on the inner box label, in compliance with JEDEC Standard JESD97. The maximum ratings related to soldering conditions are also marked on the inner box label. ECOPACK is an ST trademark. ECOPACK specifications are available at: www.st.com

Obsolete Product(s) - Obsolete Product(s)

Table 59. TFBGA Mechanical data

Dim.	mm.			inch		
	Min	Typ	Max	Min	Typ	Max
A	1.1	1	1.16	0.043	0.039	0.046
A1			0.25			0.010
A2		0.78	0.86		0.031	0.034
b	0.30	0.25	0.35	0.012	0.010	0.014
D	3.60	3.50	3.70	0.142	0.138	0.146
D1	3.50			0.138		
E	3.50	3.60	3.70	0.142	0.138	0.146
E1	2.50			0.098		
e	0.50			0.020		
F	0.55			0.022		

Figure 15. Package dimensions

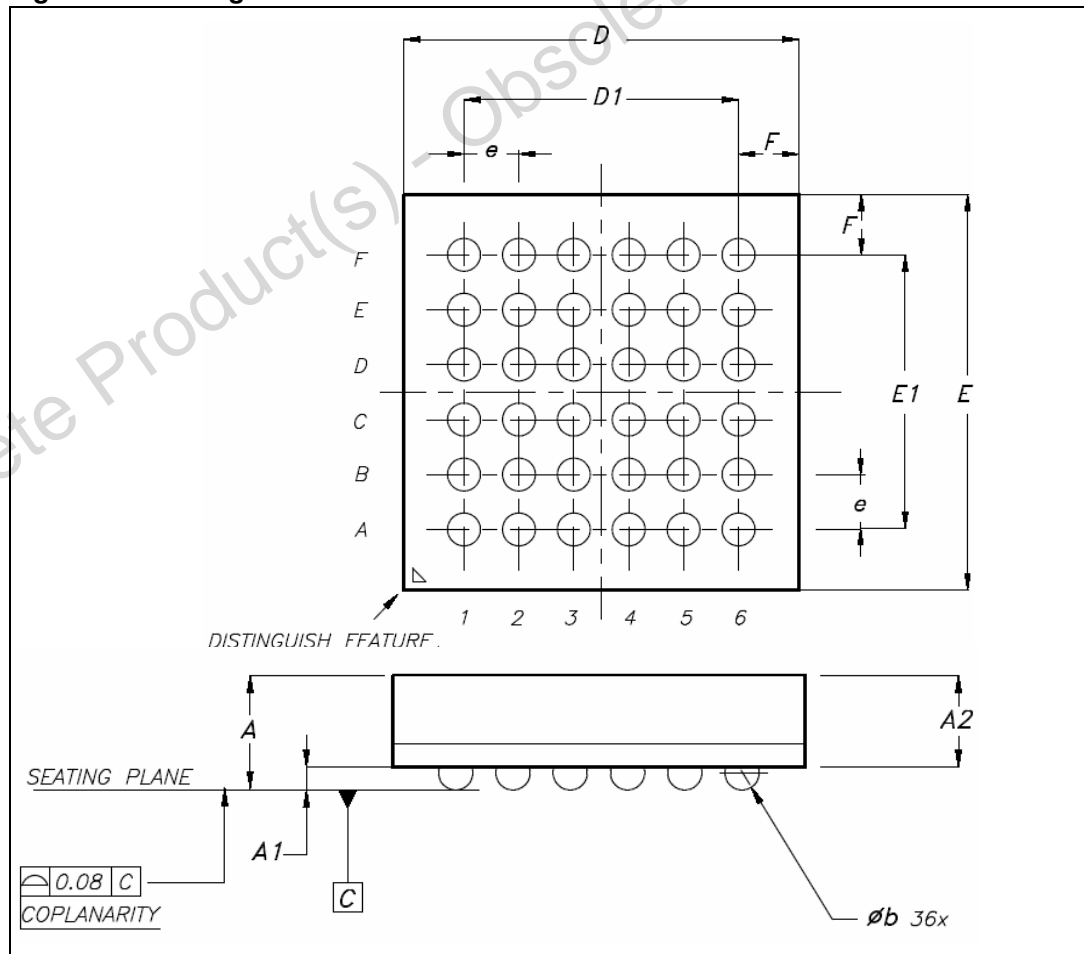

Figure 16. Recommended footprint

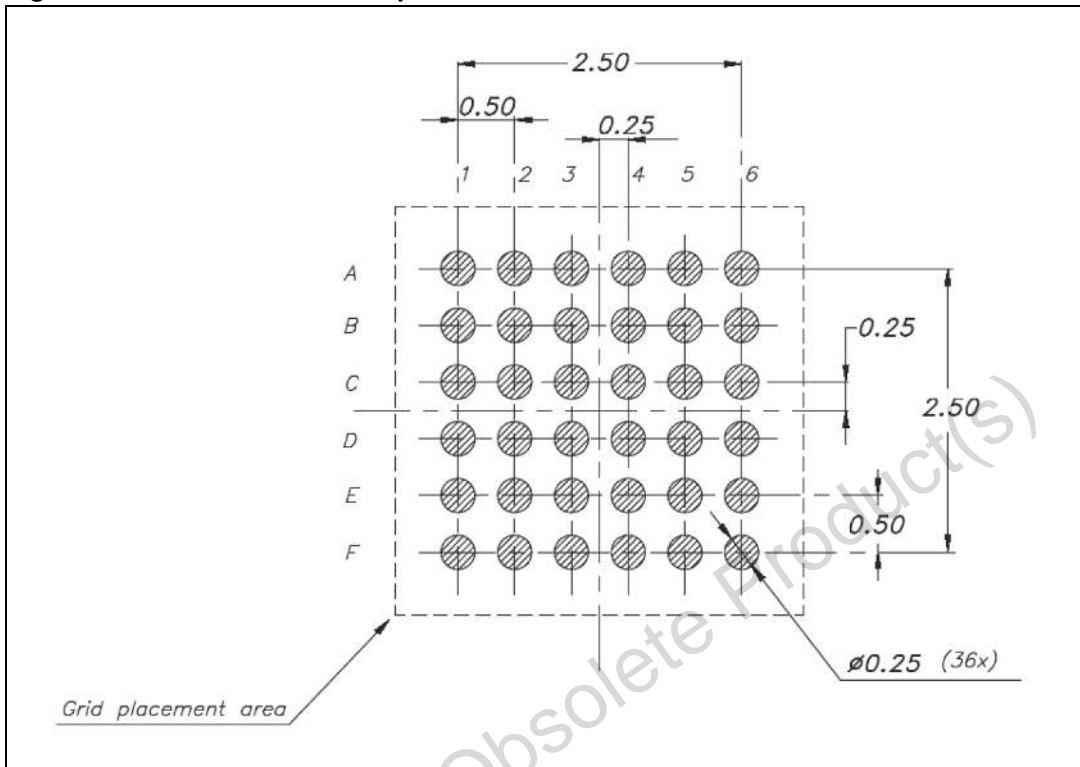
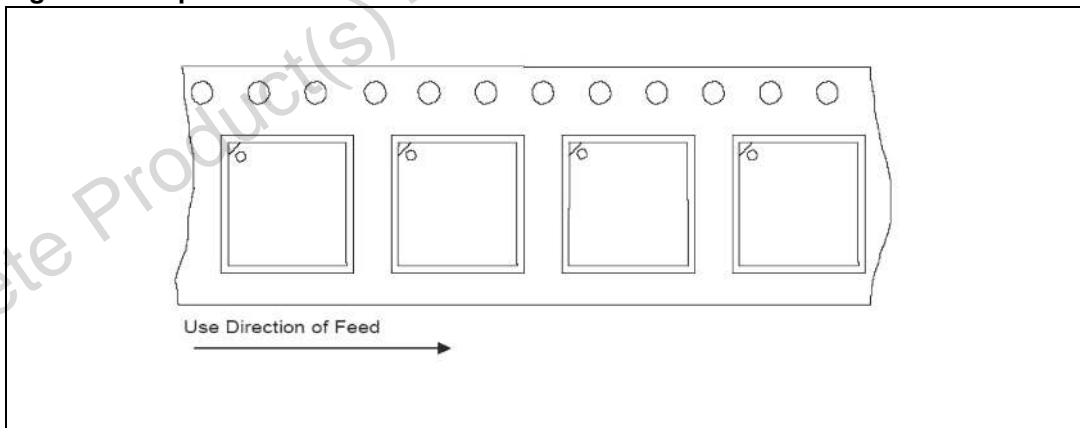

Figure 17. Tape and reel information



16 Revision history

Table 60. Revision history

Date	Revision	Changes
08-Jun-2007	1	Initial release

Obsolete Product(s) - Obsolete Product(s)

Please Read Carefully:

Information in this document is provided solely in connection with ST products. STMicroelectronics NV and its subsidiaries ("ST") reserve the right to make changes, corrections, modifications or improvements, to this document, and the products and services described herein at any time, without notice.

All ST products are sold pursuant to ST's terms and conditions of sale.

Purchasers are solely responsible for the choice, selection and use of the ST products and services described herein, and ST assumes no liability whatsoever relating to the choice, selection or use of the ST products and services described herein.

No license, express or implied, by estoppel or otherwise, to any intellectual property rights is granted under this document. If any part of this document refers to any third party products or services it shall not be deemed a license grant by ST for the use of such third party products or services, or any intellectual property contained therein or considered as a warranty covering the use in any manner whatsoever of such third party products or services or any intellectual property contained therein.

UNLESS OTHERWISE SET FORTH IN ST'S TERMS AND CONDITIONS OF SALE ST DISCLAIMS ANY EXPRESS OR IMPLIED WARRANTY WITH RESPECT TO THE USE AND/OR SALE OF ST PRODUCTS INCLUDING WITHOUT LIMITATION IMPLIED WARRANTIES OF MERCHANTABILITY, FITNESS FOR A PARTICULAR PURPOSE (AND THEIR EQUIVALENTS UNDER THE LAWS OF ANY JURISDICTION), OR INFRINGEMENT OF ANY PATENT, COPYRIGHT OR OTHER INTELLECTUAL PROPERTY RIGHT.

UNLESS EXPRESSLY APPROVED IN WRITING BY AN AUTHORIZED ST REPRESENTATIVE, ST PRODUCTS ARE NOT RECOMMENDED, AUTHORIZED OR WARRANTED FOR USE IN MILITARY, AIR CRAFT, SPACE, LIFE SAVING, OR LIFE SUSTAINING APPLICATIONS, NOR IN PRODUCTS OR SYSTEMS WHERE FAILURE OR MALFUNCTION MAY RESULT IN PERSONAL INJURY, DEATH, OR SEVERE PROPERTY OR ENVIRONMENTAL DAMAGE. ST PRODUCTS WHICH ARE NOT SPECIFIED AS "AUTOMOTIVE GRADE" MAY ONLY BE USED IN AUTOMOTIVE APPLICATIONS AT USER'S OWN RISK.

Resale of ST products with provisions different from the statements and/or technical features set forth in this document shall immediately void any warranty granted by ST for the ST product or service described herein and shall not create or extend in any manner whatsoever, any liability of ST.

ST and the ST logo are trademarks or registered trademarks of ST in various countries.

Information in this document supersedes and replaces all information previously supplied.

The ST logo is a registered trademark of STMicroelectronics. All other names are the property of their respective owners.

© 2007 STMicroelectronics - All rights reserved

STMicroelectronics group of companies

Australia - Belgium - Brazil - Canada - China - Czech Republic - Finland - France - Germany - Hong Kong - India - Israel - Italy - Japan - Malaysia - Malta - Morocco - Singapore - Spain - Sweden - Switzerland - United Kingdom - United States of America

www.st.com