

For Top Entry

For Bottom Entry

Recommended PCB Layouts

▨ Solder Area

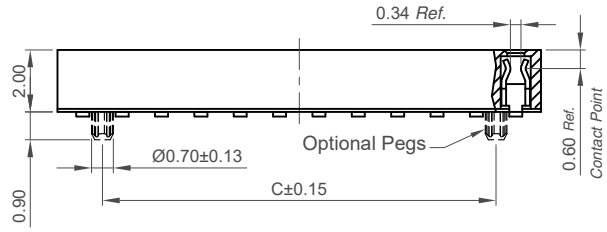
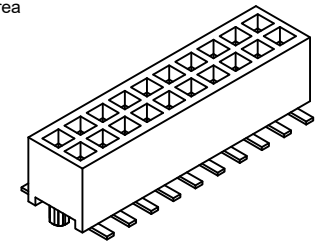
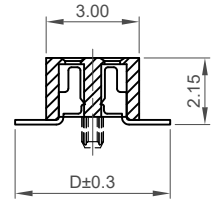

Number of Contacts	Dimensions		
	A	B	C
4	1.27	2.78	/
6	2.54	4.05	1.27
8	3.81	5.32	2.54
10	5.08	6.59	3.81
12	6.35	7.86	5.08
14	7.62	9.13	6.35
16	8.89	10.40	7.62
18	10.16	11.67	8.89
20	11.43	12.94	10.16
22	12.70	14.21	11.43
24	13.97	15.48	12.70
26	15.24	16.75	13.97
28	16.51	18.02	15.24
30	17.78	19.29	16.51
32	19.05	20.56	17.78
34	20.32	21.83	19.05
36	21.59	23.10	20.32
38	22.86	24.37	21.59
40	24.13	25.64	22.86
42	25.40	26.91	24.13
44	26.67	28.18	25.40
46	27.94	29.45	26.67
48	29.21	30.72	27.94
50	30.48	31.99	29.21
52	31.75	33.26	30.48
54	33.02	34.53	31.75
56	34.29	35.80	33.02
58	35.56	37.07	34.29
60	36.83	38.34	35.56
62	38.10	39.61	36.83
64	39.37	40.88	38.10
66	40.64	42.15	39.37
68	41.91	43.42	40.64
70	43.18	44.69	41.91
72	44.45	45.96	43.18
74	45.72	47.23	44.45
76	46.99	48.50	45.72
78	48.26	49.77	46.99
80	49.53	51.04	48.26

Specifications

Material
 Insulator: LCP, UL 94V-0
 Terminal: Phosphor Bronze

Plating
 See Ordering Grid

Electrical
 Current Rating: 1A per pin
 Contact Resistance: 20 mΩ max.
 Insulating Resistance: 1000 MΩ min.
 Dielectric Withstand Voltage: 500V AC

Mechanical & Environmental
 Operating Temperature: -40°C to +105°C
 Soldering Process:
 IR Reflow: 260°C for 10 sec.
 Manual Solder: 350°C for 3-5 sec

Ordering Grid

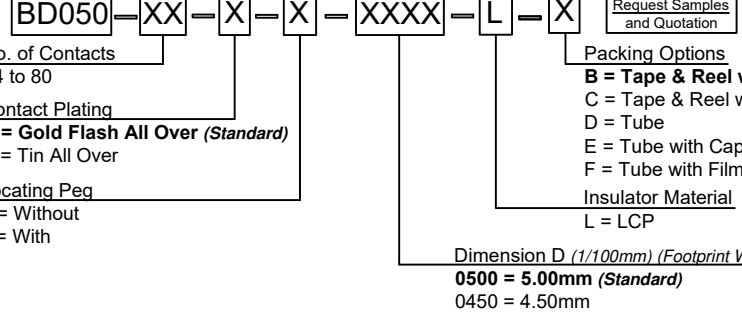

Mates with (Subject to pin length)
 BD025 BD030 BD035
 BD038 BD040 BD095

For bottom entry applications, stringent soldering control & pin alignment are required as lead to pad misalignment could cause incorrect mating.

Part Number		Product Description	
BD050		1.27mm Pitch Socket	
Drawing Date		Dual Row, Surface Mount, Low Profile, Dual Entry	
28th December 2007			
By	CC	Tolerances (Except as Noted)	Units:
Detail	BD050 K PCN	Length X. ± 0.30 X.X ± 0.25 X.XX ± 0.15 X.XXX ± 0.10	Metric (mm)
Revision	K	Angle X° ± 5° X.X° ± 3° X.XX° ± 2° X.XXX° ± 1°	
Date	09/02/22		

GCT
 www.gct.co

This drawing is confidential and copyright of Global Connector Technology, Ltd (GCT). This drawing must not be copied or disclosed without written consent. E & OE

Not to Scale | Drawn By PKN | Sheet No. 1/1