

SERPAC 194i (exploded isometric)

Electronic Enclosures

-Click on image to show toolbar. Use  to Play/Pause Animation.
 -Left click and drag on image to move 3D model.

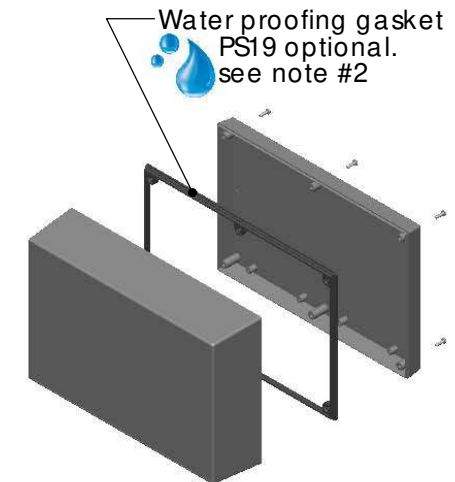
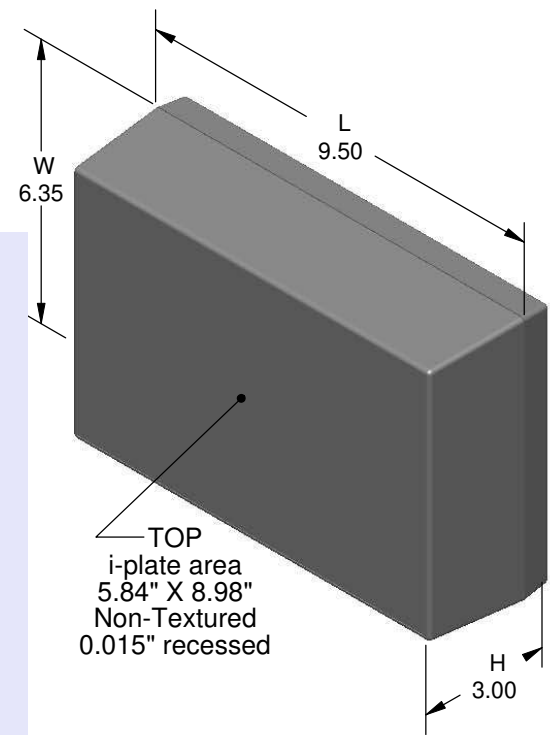
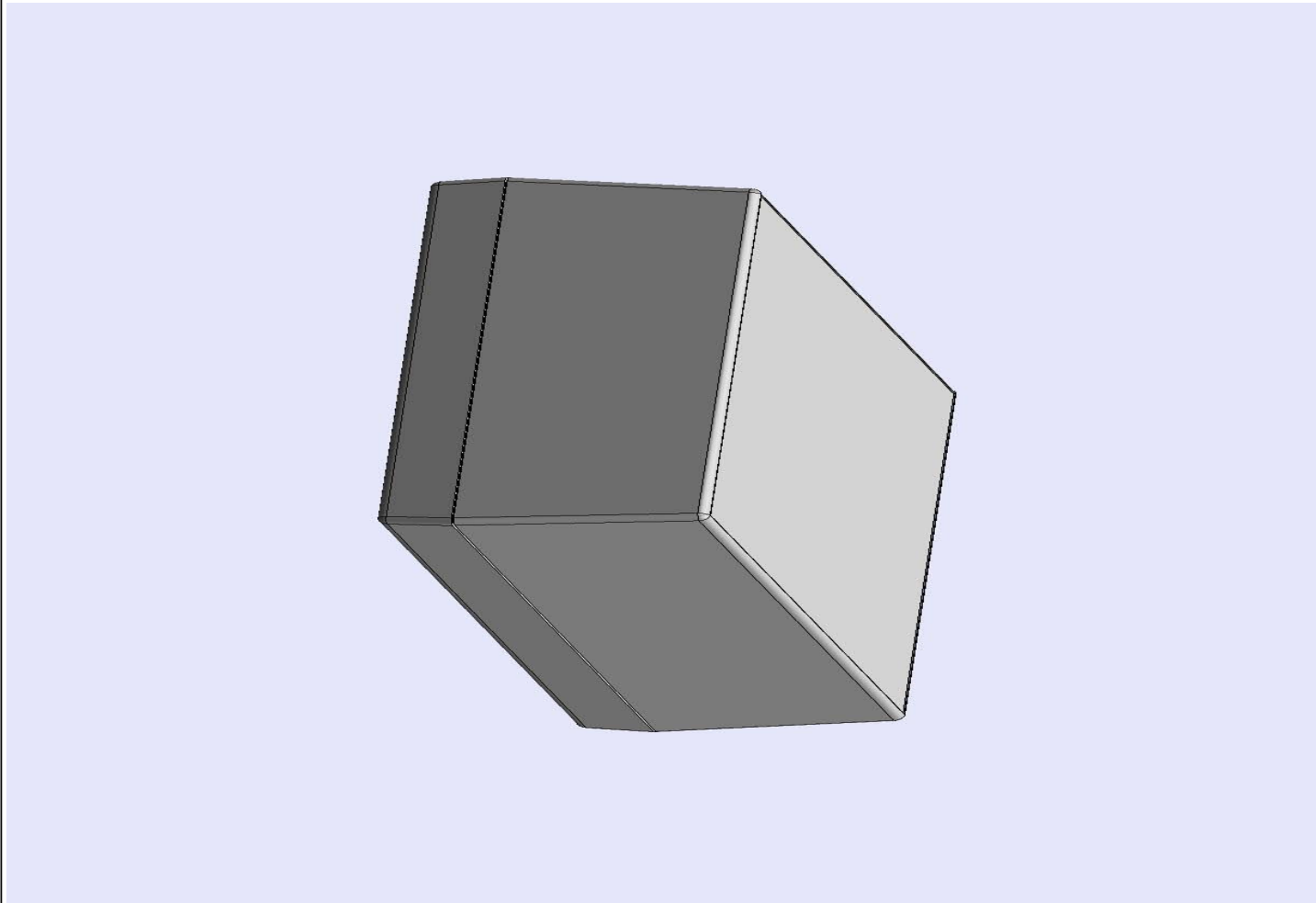

- a) Zoom in & out with center wheel.
- b) Pause at any moment to view and or print views.
- c) Change the views to ortho and section views if needed from the Views pull down menu.
- d) Explore options included in the tool bar like: Views, Transparency of model, Lighting type, etc.

PART NO.	DESCRIPTION (Included)	ACCESSORIES (Optional)	
9-4-i	TOP	PART NO.	DESCRIPTION
19	BOTTOM	51	Non-skid Feet
6005	#4X3/8" Self tapping (6)	PS19	Perimeter Seal

Notes: Enclosure weight .76 lbs/ 347 gm
 1) Enclosure meets or exceeds IP40 and NEMA 1
 2) When used with PS19 the enclosure meets or exceeds IP 66 and NEMA 4X, 12 and 13 MIL-STD-810G 506.5
 3) Circuit Board drawings can be download at:
http://www.serpac.com/Products/Sseries/x9x/drawings/09X_top-CB.pdf
 4) All components are RoHS Compliant.

ALL DIMENSIONS ARE ±.010" 3/23/10 (1 of 2)
619 Commercial Ave. Covina, CA 91723
 Ph. (626) 331-0517 Fx. (626) 331-8584 serpac.com

SERPAC 194i (user print)

Electronic Enclosures

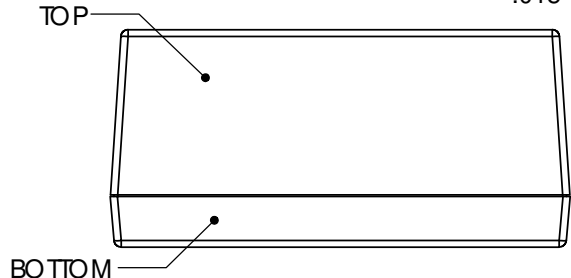
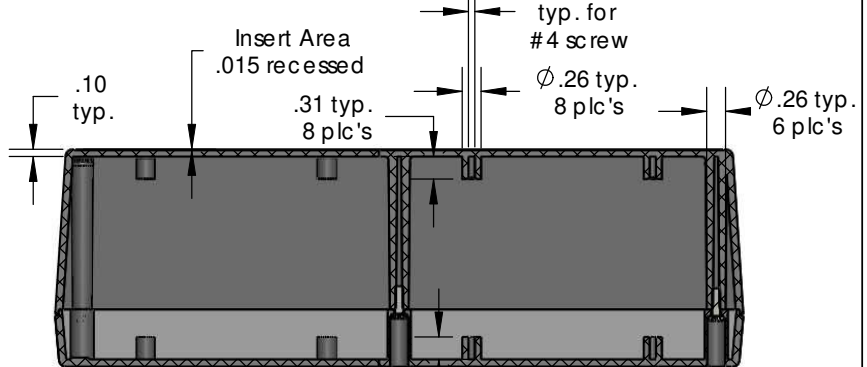
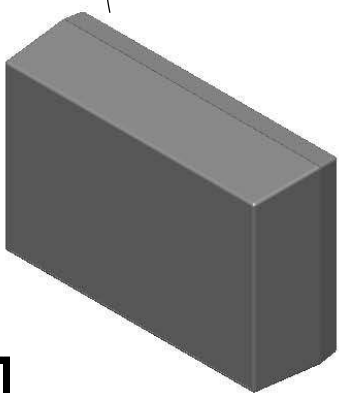
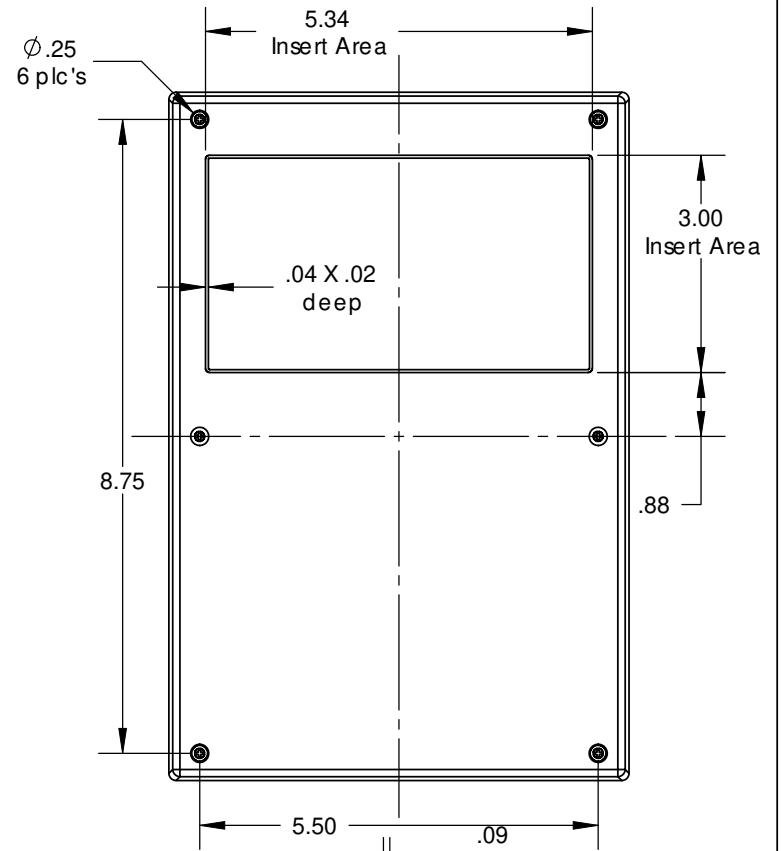
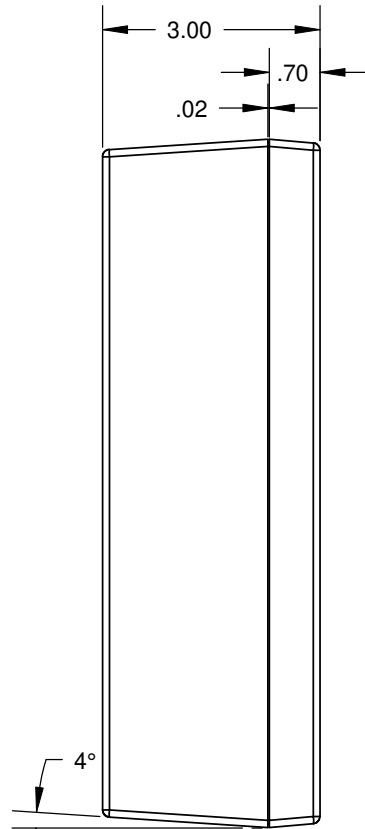
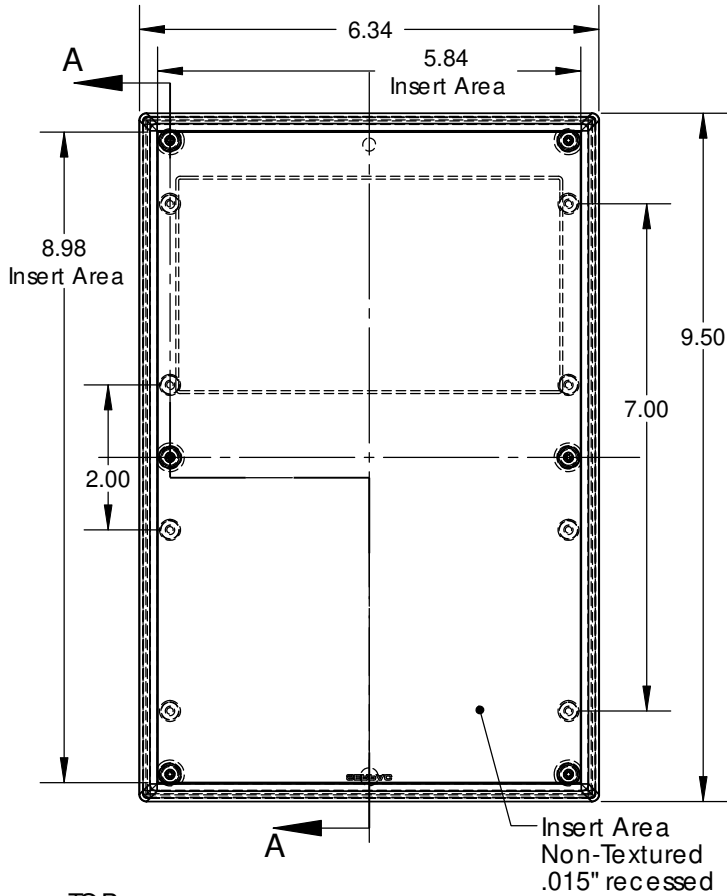

PART NO.	DESCRIPTION (Included)	ACCESSORIES (Optional)	
9-4-i	TOP	PART NO.	DESCRIPTION
19	BOTTOM	51	Non-skid Feet
6005	#4X3/8" Self tapping (6)	PS19	Perimeter Seal

Notes: Enclosure weight .76 lbs / 347 gm
 1) Enclosure meets or exceeds IP40 and NEMA 1
 2) When used with PS19 the enclosure meets or exceeds IP 66 and NEMA 4X, 12 and 13 MIL-STD-810G 506.5
 3) Circuit Board drawings can be download at:
http://www.serpac.com/Products/Series/x9x/drawings/09X_top-CB.pdf
 4) All components are RoHS Compliant.

SECTION A-A
SCALE 1 : 2.65

ALL DIMENSIONS ARE ± .010" 3/23/10 (2 of 2)
 619 Commercial Ave. Covina, CA 91723
 Ph. (626) 331-0517 Fx. (626) 331-8584 www.serpac.com