

PART NUMBER	LENGTH	CUSTOMER PN
10122193-001LF	430±10MM	04050433-004
10122193-002LF	330±10MM	04050433-002
10122193-003LF	230±10MM	04050433-003
10122193-004LF	420±10MM	N.A.
10122193-005LF	320±10MM	N.A.
10122193-006LF	220±10MM	N.A.
10122193-007LF	410±10MM	N.A.
10122193-008LF	310±10MM	N.A.
10122193-009LF	210±10MM	N.A.

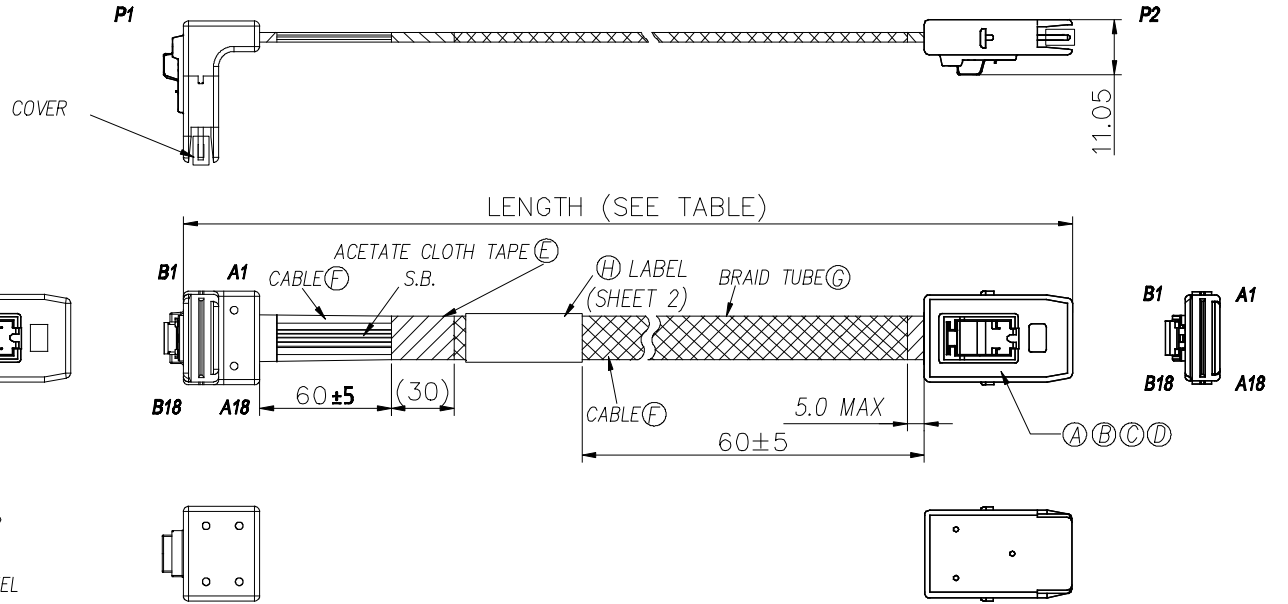

WIRE DIAGRAM

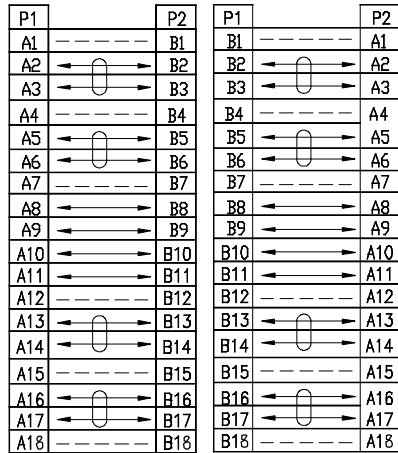

- NOTES
- 1.ROHS COMPLIANCE,EHS CLASSED AS A2
 - 2.GF FINISH FOR THE PADDLECARD
30U"MIN AU, UNDERPLATING 50U" NICKEL
 - 3.PRODUCT SPECIFICATION REFER TO FCI GS-12-1164
 - 4.SAS PLUG DIMENSION CONFORMS TO SFF-8086 & SFF-8087
 - 5.NO AC COUPLING APPLIED TO BOARD
 - 6.ACETATE CLOTH TAPE WRAPPED AROUND TO THE CABLE EXIST OF EACH PLUG
 - 7.SAS2.1 COMPLIANCE, DATA RATE 6Gbps.
 - 8.LABEL SPECIFICATION SEE SHEET 2.
 - 9.PACKING SPECIFICATION SEE SHEET 3.

ITEM	DESCRIPTION	QUANTITY	UNIT
I	TPC 30AWG,1/0.28, 4X FLAT RIBBON S.B. CABLE	PER LENGTH	M
H	IDENTIFICATION LABEL, SEE SHEET 2	1	PCS
G	EXPANSIBLE BRAID TUBE,BLK	1	PCS
F	8(*1P*30AWG SAS) CABLE	PER LENGTH	M
E	ACETATE CLOTH TAPE,BLK,30MM WIDTH	2	PCS
D	LATCH	2	PCS
C	PBT RESIN,BLK,FOR 36P OVERMOLD	22	G
B	PE RESIN,TRANSPARENT,INNER MOLD	15	G
A	MINISAS36POS PADDLECARD	2	PCS
BILL OF MATERIAL			

mat'l. code		surface ASME Y14.5	tolerance ASME Y14.5	projection	product family CABLE ASSEMBLY
ltr	ecn no	dr	date	tolerances unless otherwise specified	title MINISAS36P TO MINISAS36P STR CABLE ASSY
1			070313	angles X.±0.5	
2			011514	parallelism X.X±0.25	sheet 1 of 3 size A4
3			022514	perpendicularity X.XX±0.13	
A			031314	dr Beer Fu	FCI type INSPECTION Drawing
B			052114	enr Beer Fu	
				chr Beer Fu	
				appd Beer Fu	
sheet index	revision sheet	B 1	B 2	B 3	

LABEL SPECIFICATION

CABLE LABEL SPEC.:

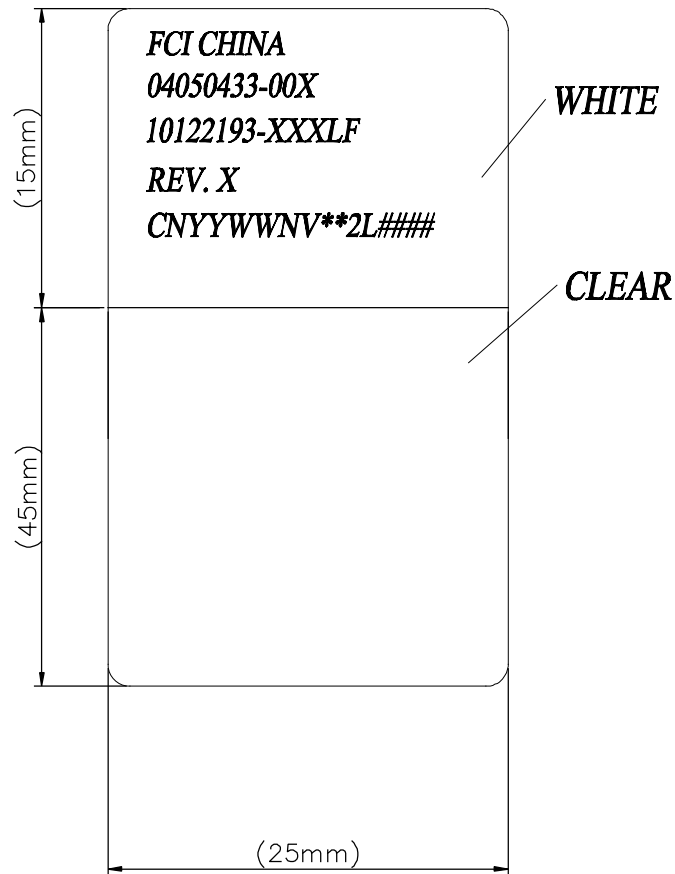

LABEL NOTES:

A. FCI CHINA

-THE PRODUCT IS MADE IN FCI CHINA

B. CUSTOMER PART NUMBER

04050433-00X is customer's P/N. (See sheet 1, P/N list)

C. FCI PN and Revision

10122193-XXXLF (NOTE: FCI PART NUMBER, SEE SHEET 1 TABLE)

Rev. X (DRAWING REVISION, SEE DRAWING FRAME)

D. CNYWWNV2L####**

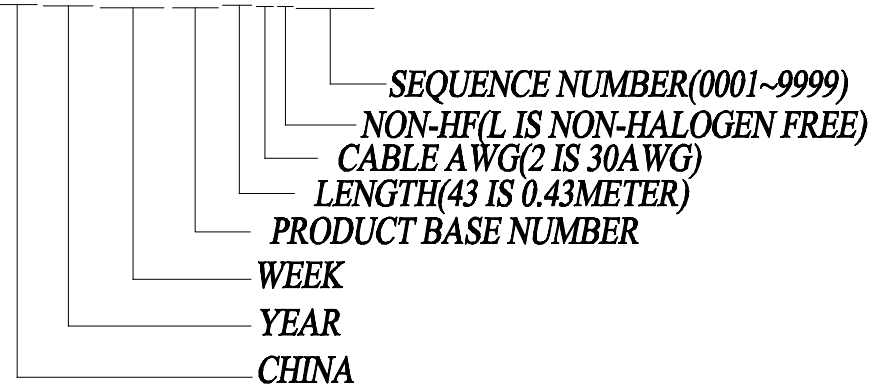

dwg no	sheet 2 of 3	size
10122193		A4
type	CUSTOMER Drawing	

sheet index	revision sheet	B 1	B 2	B 3																
-------------	----------------	-----	-----	-----	--	--	--	--	--	--	--	--	--	--	--	--	--	--	--	--

PACKING SPECIFICATION

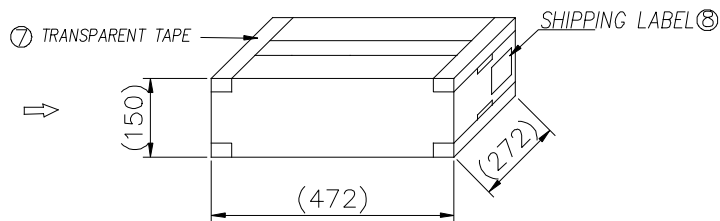
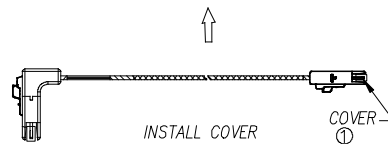
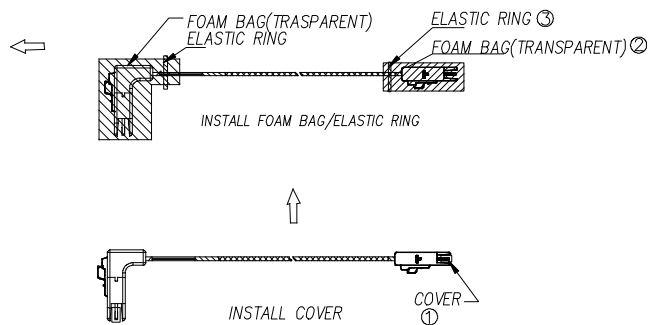
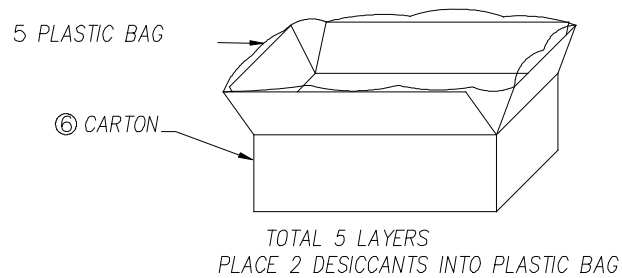
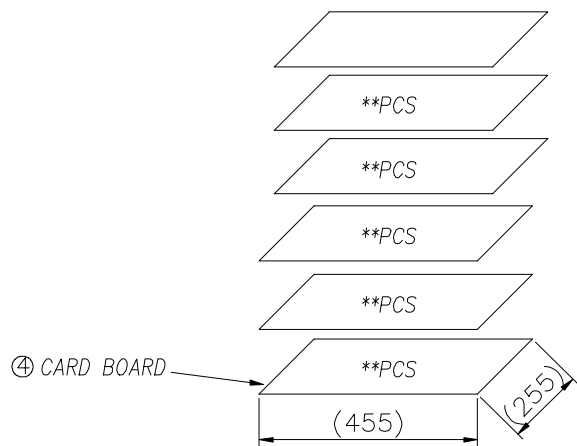

PART NUMBER	PCS/LAYER	PCS/CARTON
10122193-001LF	TBD	TBD
10122193-002LF	TBD	TBD
10122193-003LF	TBD	TBD
10122193-004LF	TBD	TBD
10122193-005LF	TBD	TBD
10122193-006LF	TBD	TBD
10122193-007LF	TBD	TBD
10122193-008LF	TBD	TBD
10122193-009LF	TBD	TBD



dwg no 10122193 sheet 3 of 3 size A4
type CUSTOMER Drawing

sheet index	revision sheet	B 1	B 2	B 3														