

P	LTR	DESCRIPTION	DATE	DWN	APVD
	B	INITIAL RELEASE	15OCT2020	GK	MN

LABEL AND LINER DESIGN

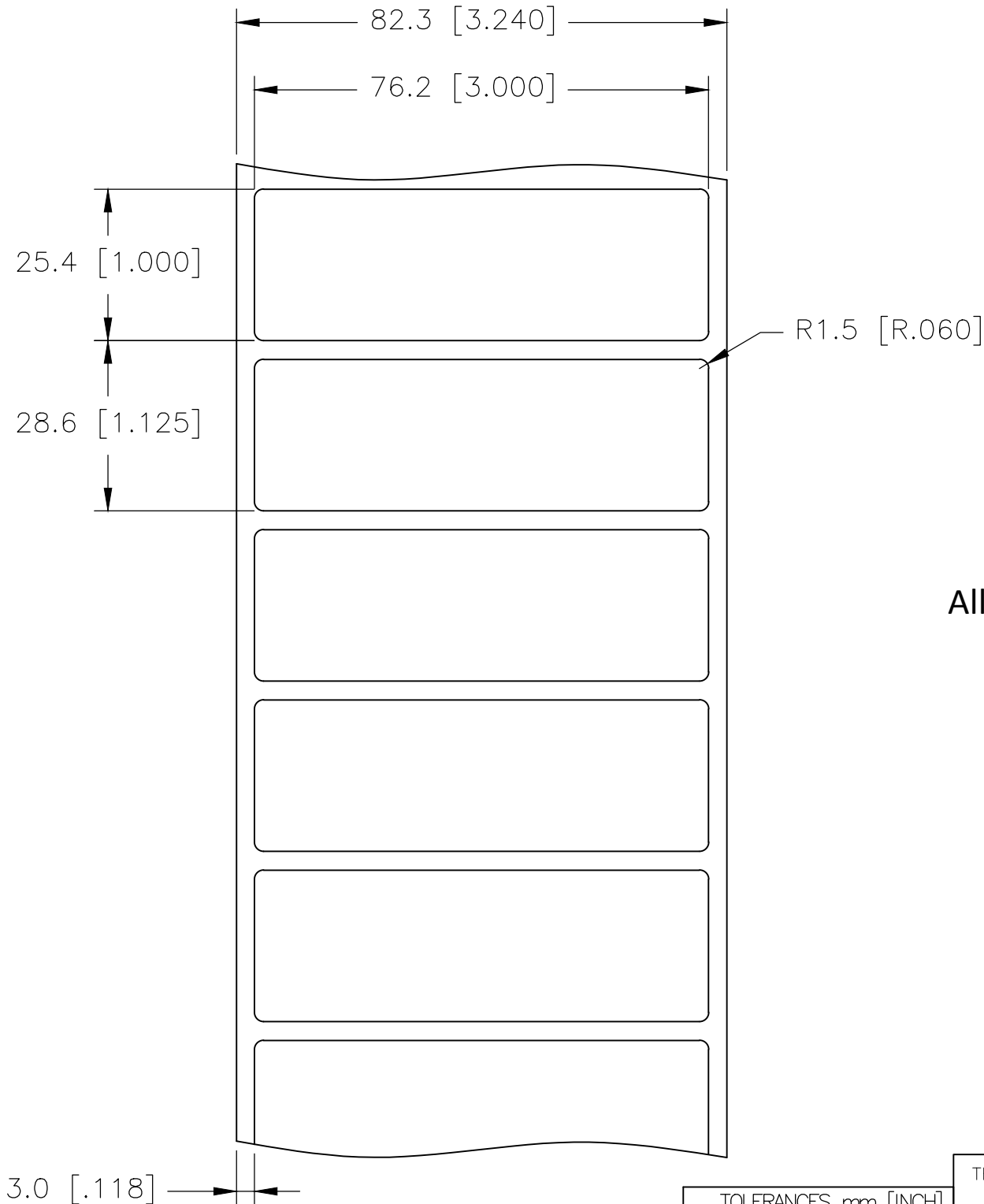

PRESENTATION

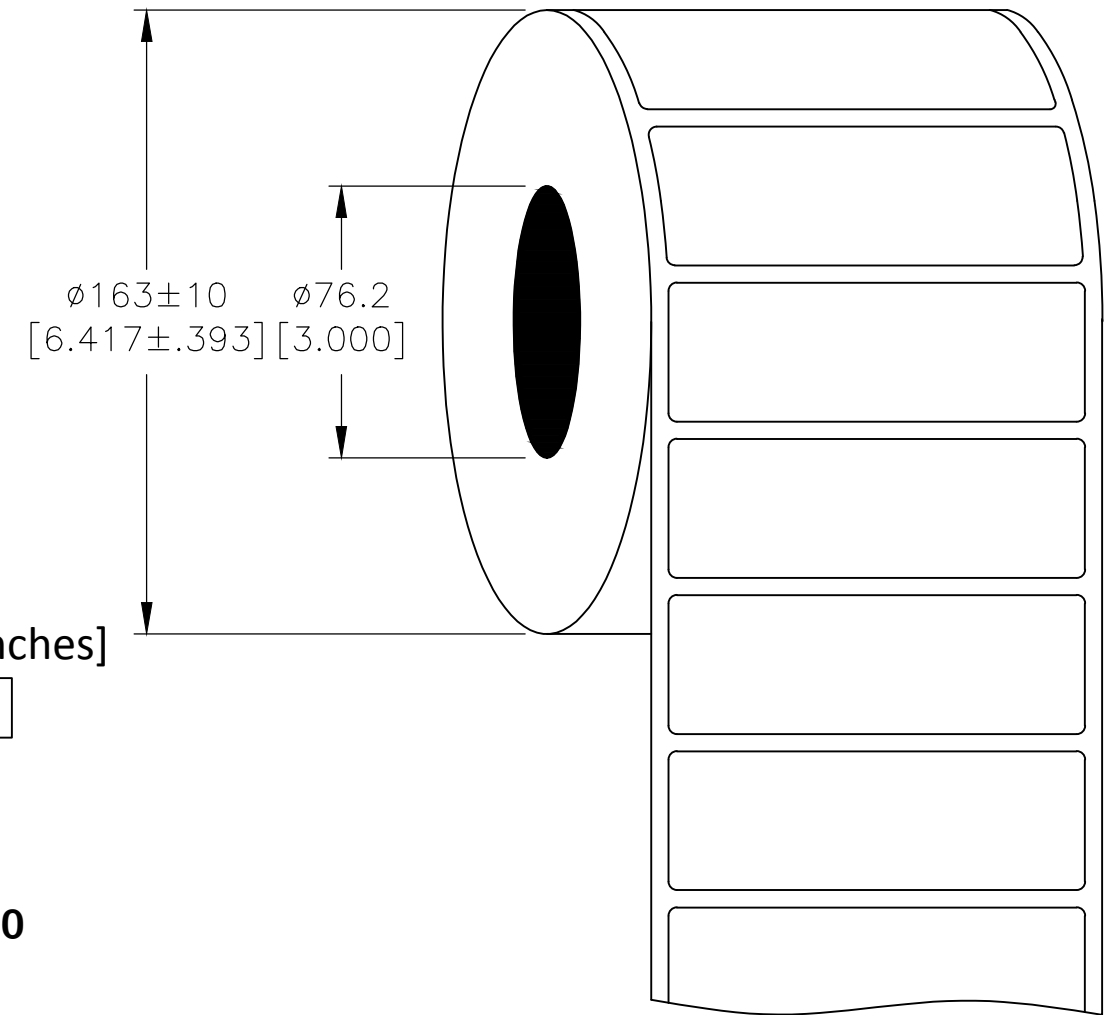

All dimensions in mm [Inches]

TE PN: E56997-000

**OUTSIDE WOUND
LABEL ACROSS: 1
PER ROLL QTY: 5000**

MATERIAL	HIGH TACK MATTE METALIZED POLYESTER
ADHESIVE TYPE	PERMANENT ACRYLIC
LINER	GLASSINE PAPER

THIS DRAWING IS A CONTROLLED DOCUMENT.

TOLERANCES mm [INCH]	
LABEL HEIGHT:	±0.3 [.012]
LABEL WIDTH:	±0.3 [.012]
WEB WIDTH:	±0.8 [.031]
VERTICAL REPEAT:	±0.8 [.031]*
HORIZONTAL REPEAT:	±0.8 [.031]*
PRINT POSITIONING:	±0.8 [.031]*
LEFT MARGIN:	±0.4 [.016]
QUANTITY:	-0 % +2 %
*NON ACCUMULATING	

DIMENSIONS:	TOLERANCES UNLESS OTHERWISE SPECIFIED:
mm [INCHES]	
	0 PLC ± -
	1 PLC ± -
	2 PLC ± -
	3 PLC ± -
	4 PLC ± -
ANGLES	± -
FINISH	-

DWN	15OCT2020
GOPALAKRISHNA HV	
CHK	15OCT2020
MIKE NUTTALL	
APVD	15OCT2020
MIKE NUTTALL	
PRODUCT SPEC	
TTDS-118	
APPLICATION SPEC	
WEIGHT	0.252g

TE Connectivity		NAME	
		HMM - HIGH TACK MATTE METALIZED POLYESTER LABELS	
SIZE	CAGE CODE	DRAWING NO	RESTRICTED TO
A3	C2290	C-HMM-762254-5-8A	-
CUSTOMER DRAWING		SCALE	SHEET
		NTS	1 OF 1
		REV	B