

Simple cell balancer

EDLC cell balance LSI

BD14000EFV-C evaluation board

BD14000EFV-EVK-001

Summary

BD14000EFV-EVK-001 realizes stand-alone cell balance of 4-6 cell series EDLC using EDLC cell balance LSI (BD14000EFV-C). The cell balance current can be set by shunt resistance. In addition, the cell balance voltage is settable, too.

Performance specifications (this is a representative figure and characteristic is not guaranteed)

VIN = 15V, unless otherwise specified

Parameter	Min	Typ	Max	Units	Conditions
Input voltage range	8.0		24	V	
Cell balance current		100		mA	Vcn-Vcn-1 = 2.5V

Cell balance detection voltage setting : It is settable at VCB = 2.4-3.1V (0.1V step)

Overvoltage detection voltage setting 1 : It is settable at VOVLO1 = VCB+0.15V or 0.25V

Overvoltage detection voltage setting 2 : It is settable at VOVLO2 = VCB+0.30V or 0.50V

Operating procedure

1. Necessary apparatus
 - (1) EDLC from 4 cell to 6 cell
 - (2) The constant current power supply which is available for voltage upper limit setting
 - (3) Monitor with the oscilloscope or DC voltmeter
2. Connection of an apparatus
 - (1) Connect EDLC to a board by soldering.
 - (2) Connect a constant current power supply to plus side of the high-end cell of EDLC and minus side of the last cell and set a charge current and a voltage upper limit level.
 - (3) Set the detection voltage by VSET0-2,OVLOSEL pin setting. (please set it in either H/L by all means.)
 - (4) Set ENIN pin setting in 'H' to turn on this LSI.
 - (5) Turn on a constant current source and do charge ⇔ discharge.

When cell voltage is not balanced, cell balance can be realized by repeating charge and discharge several times.

 - (6) The operation can be checked by monitoring the current between each cell and a flag output terminal (Dn, OVLO1,2, OK).
 - (7) At a end time of evaluation, please completely discharge EDLC by a constant current source.

* The ENIN,VSET01,2,OVLOSEL setting, please connect a monitor pin to H·VREG/L·VSS.

It is available to use 2 point of contact switches for the terminal logic's control.

In that case, please implement 2 point of contact switches at the parts list.

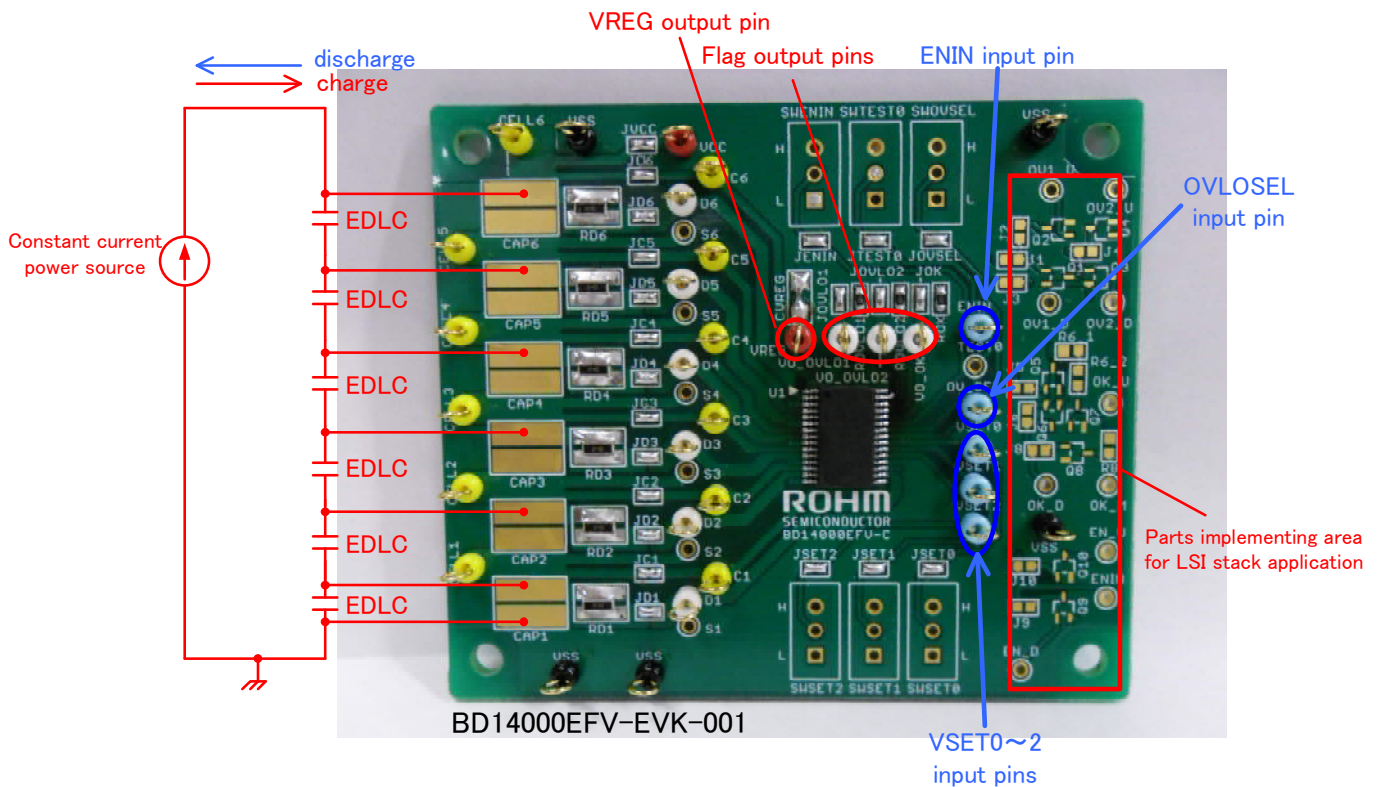

Figure 1. connection image figure



Figure 5. Bottom layer silkscreen (Top view).

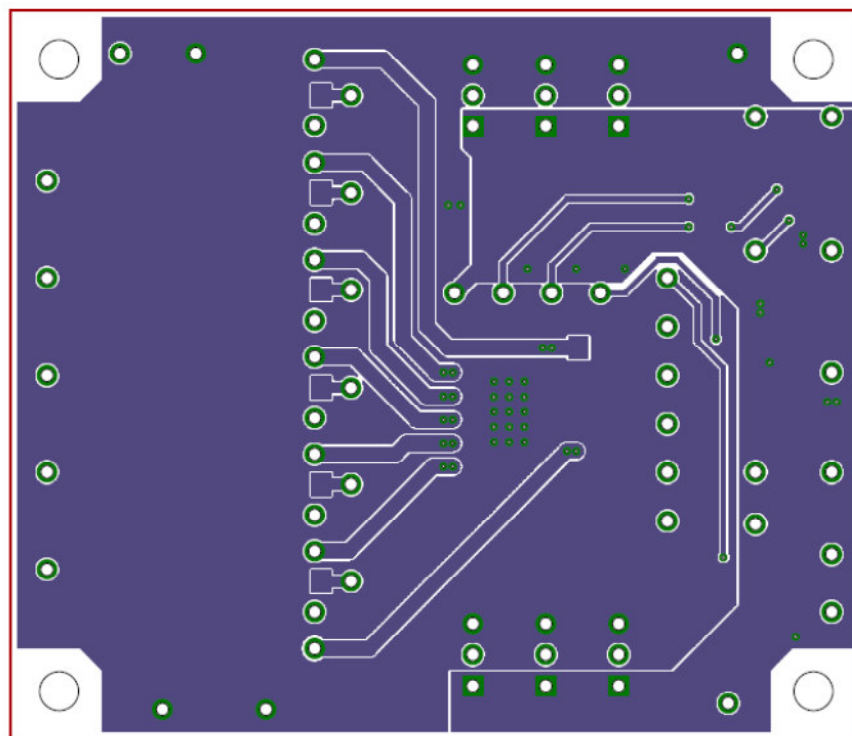

Figure 6. Bottom layer layout (Top view).

About stack of this LSI

When using the power storage element for connection of over 8 cells, series connection of this chip is possible. Enable control (ENIN pin control) and various flag output (VO_OVLO1, VO_OVLO2, the VO_OK pin output) are also available in the series connection by using the following application circuit.

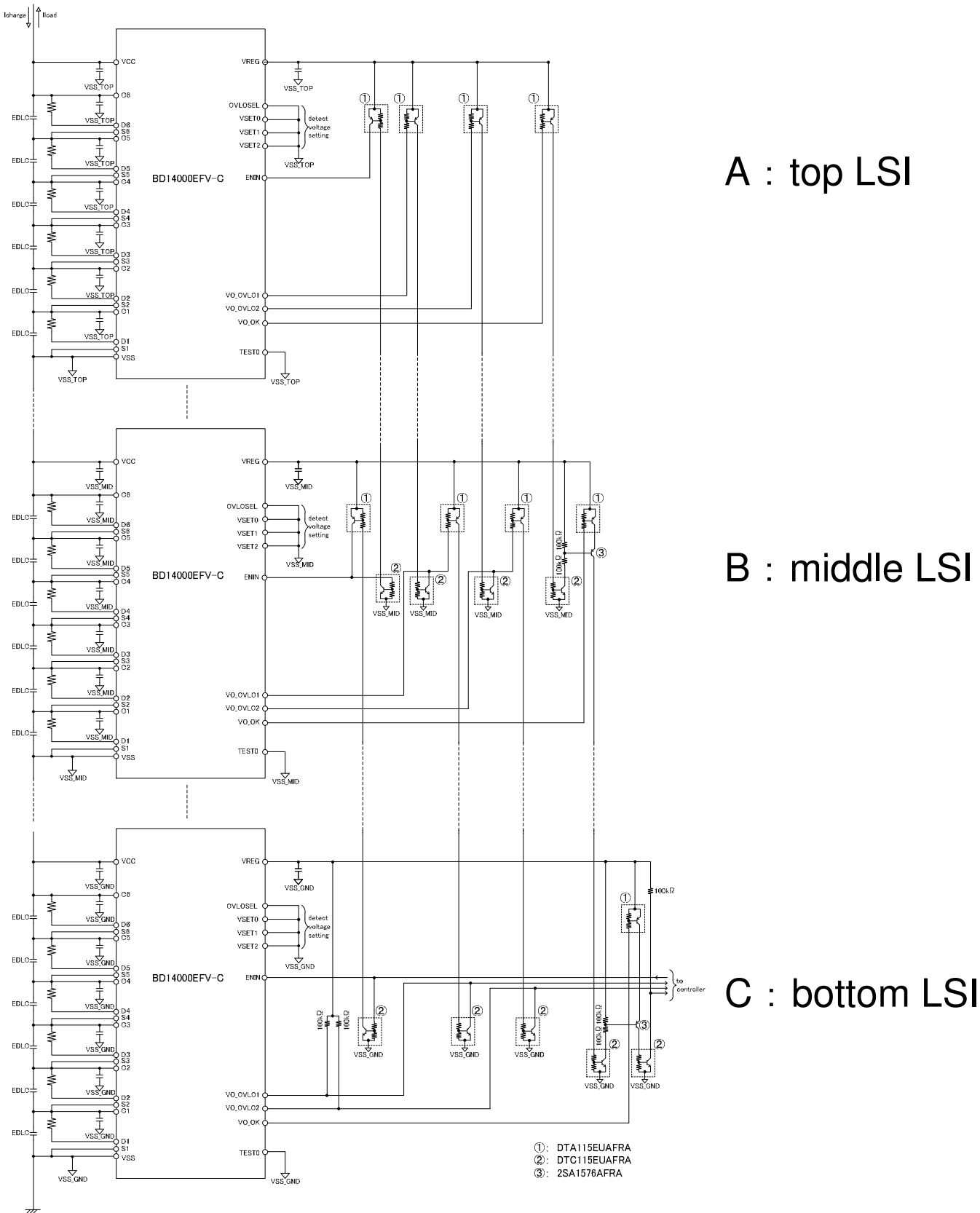

Figure 7. LSI stack application circuit example

Board connection diagrams in Top and Middle, Bottom layer are showed in the following.
 Because the parts for the LSI stack are nonimplement, please implement parts depending on a use.

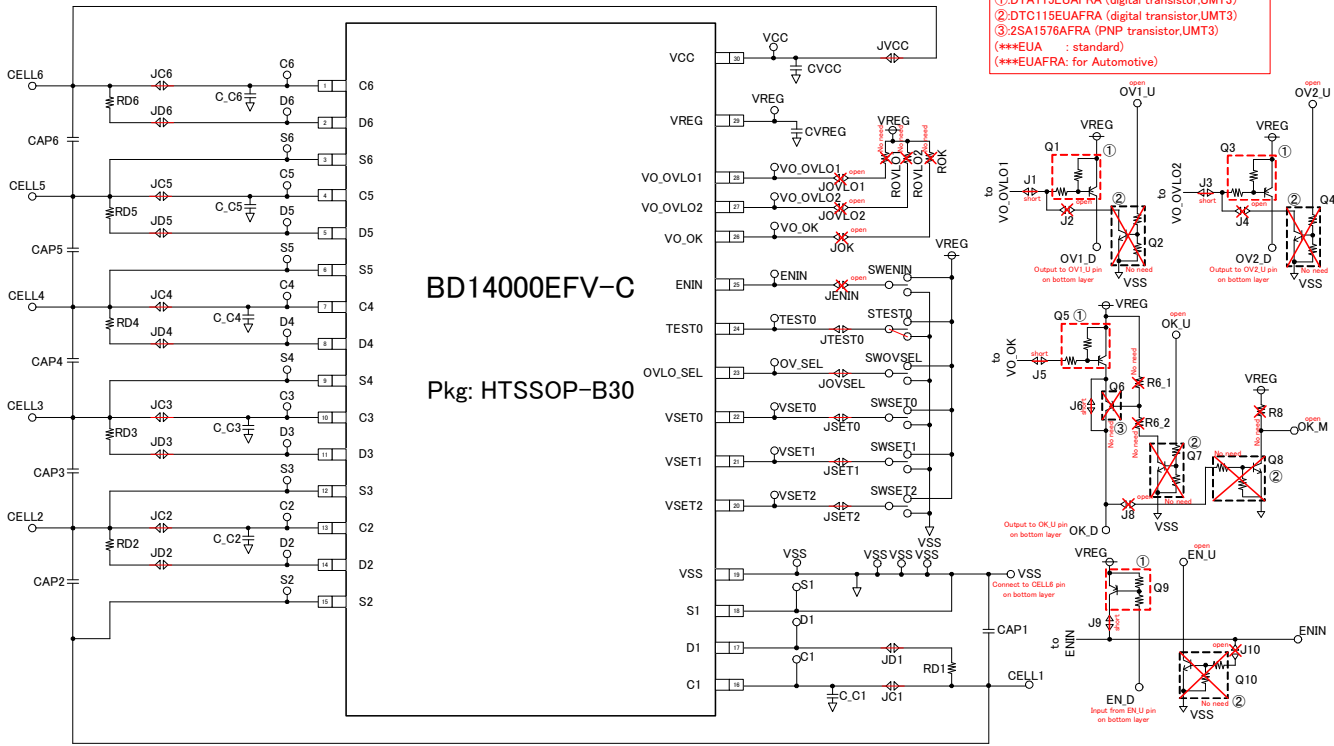

Figure 8. Top LSI board connection diagram

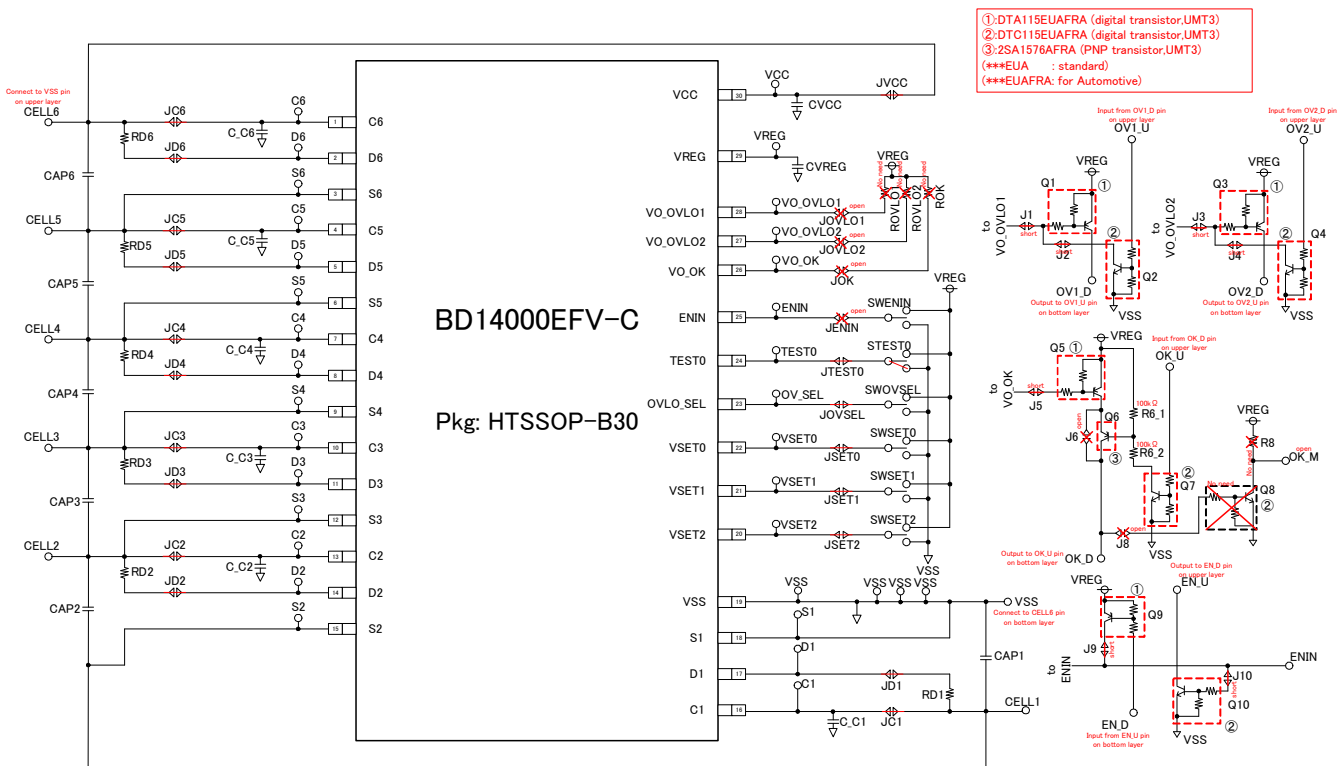

Figure 9. Middle LSI board connection diagram

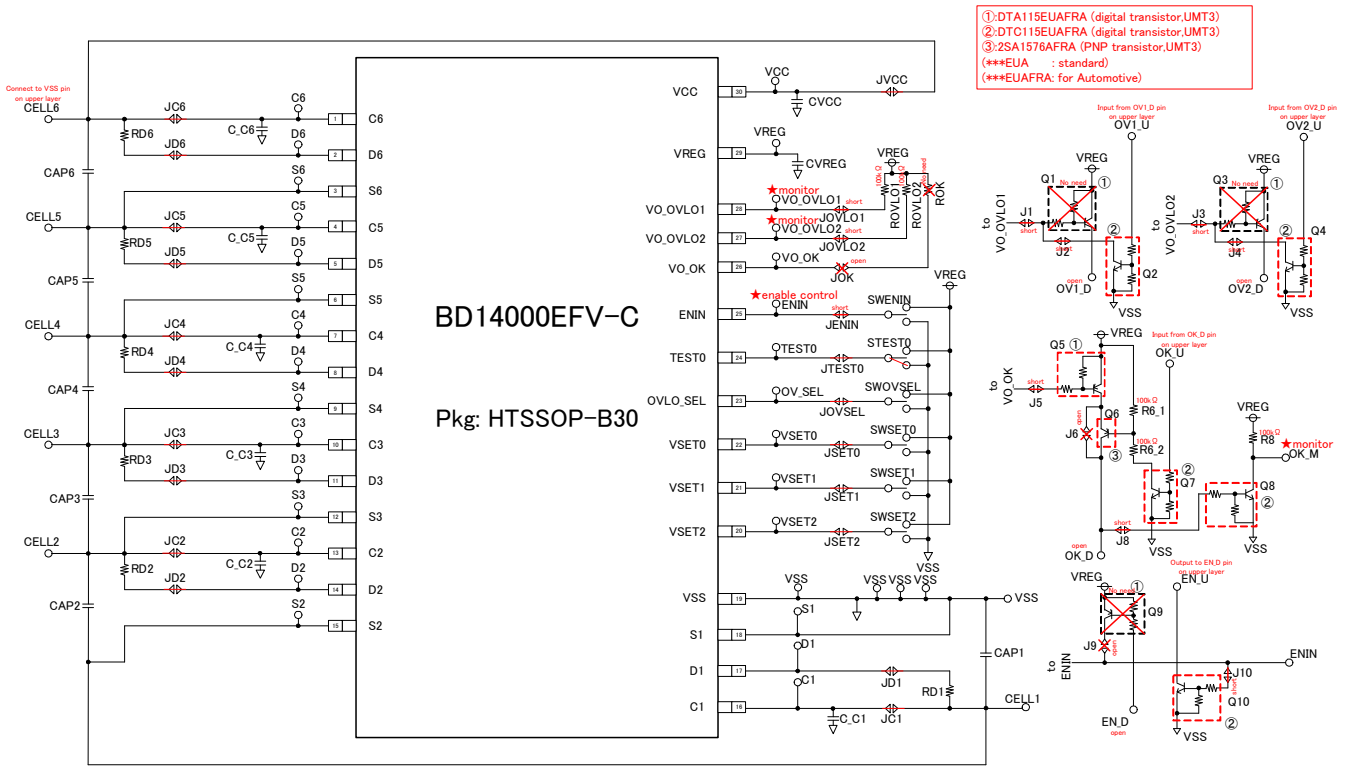

Figure 10. Bottom LSI board connection diagram

About a 4-6 cell application circuit

When using the power storage element with 4 cells and 5cells, please connect all the unused pins to the Cn pin where n is the number of actual cells in series. This chip can respond to 4 to 6 cells, but cannot respond to 3cells or fewer than 3 cells.

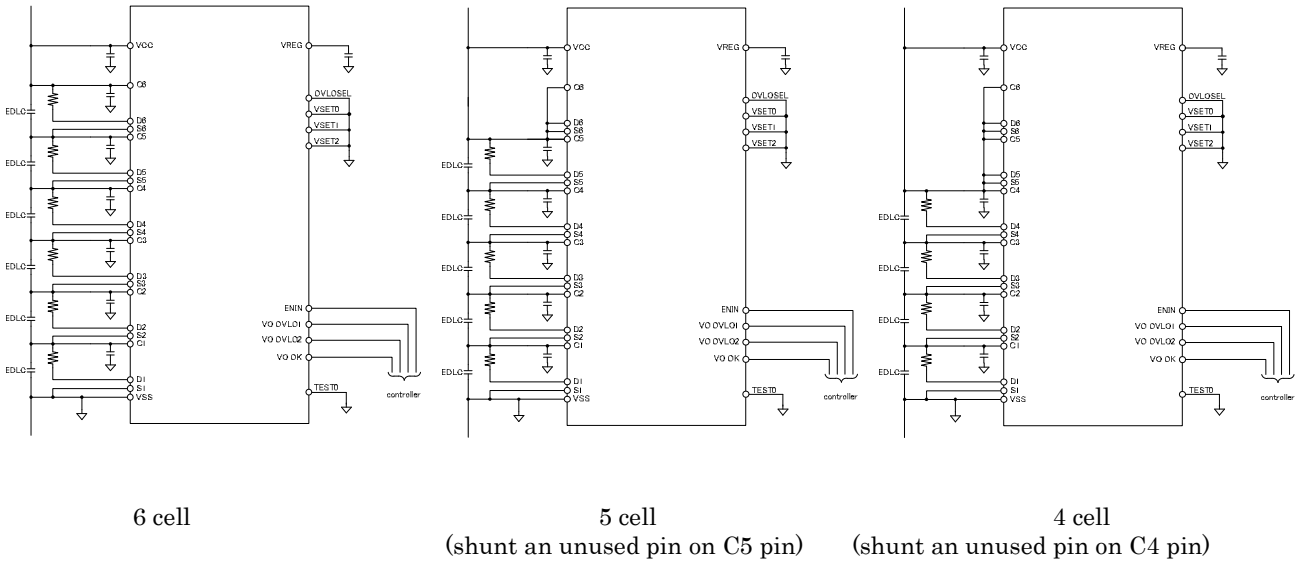

Figure 11. 4-6 cell application circuit example