

In case of consideration for using Automotive equipment / device which demand high reliability, kindly contact our sales window correspondents.

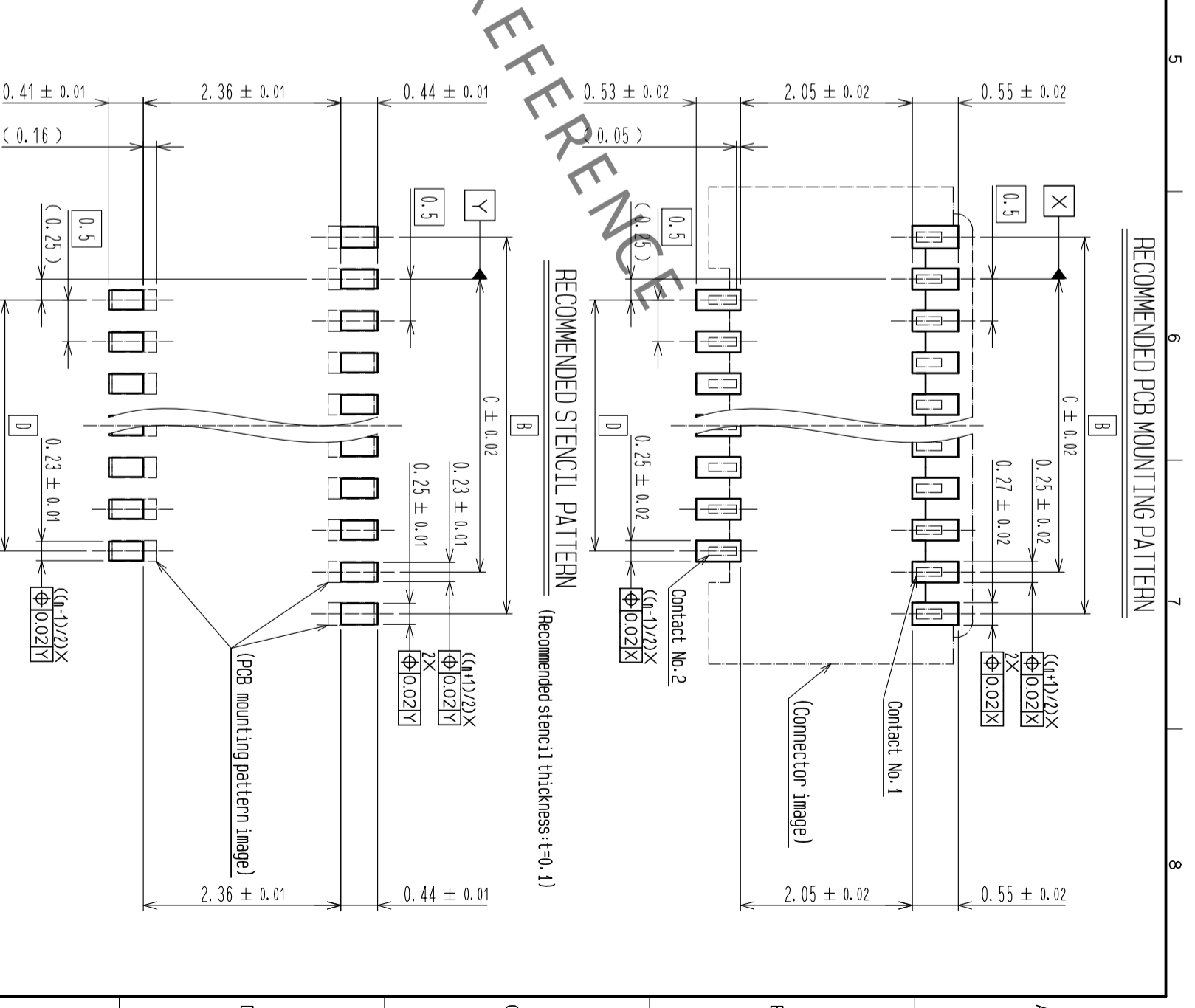
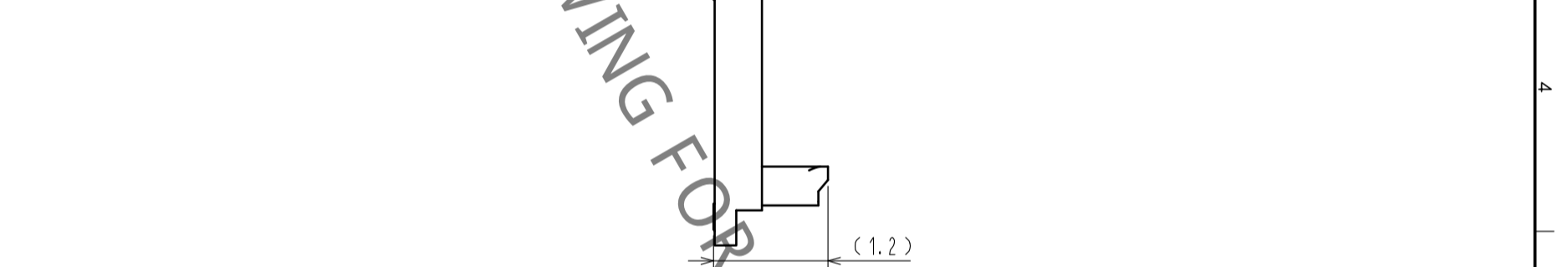
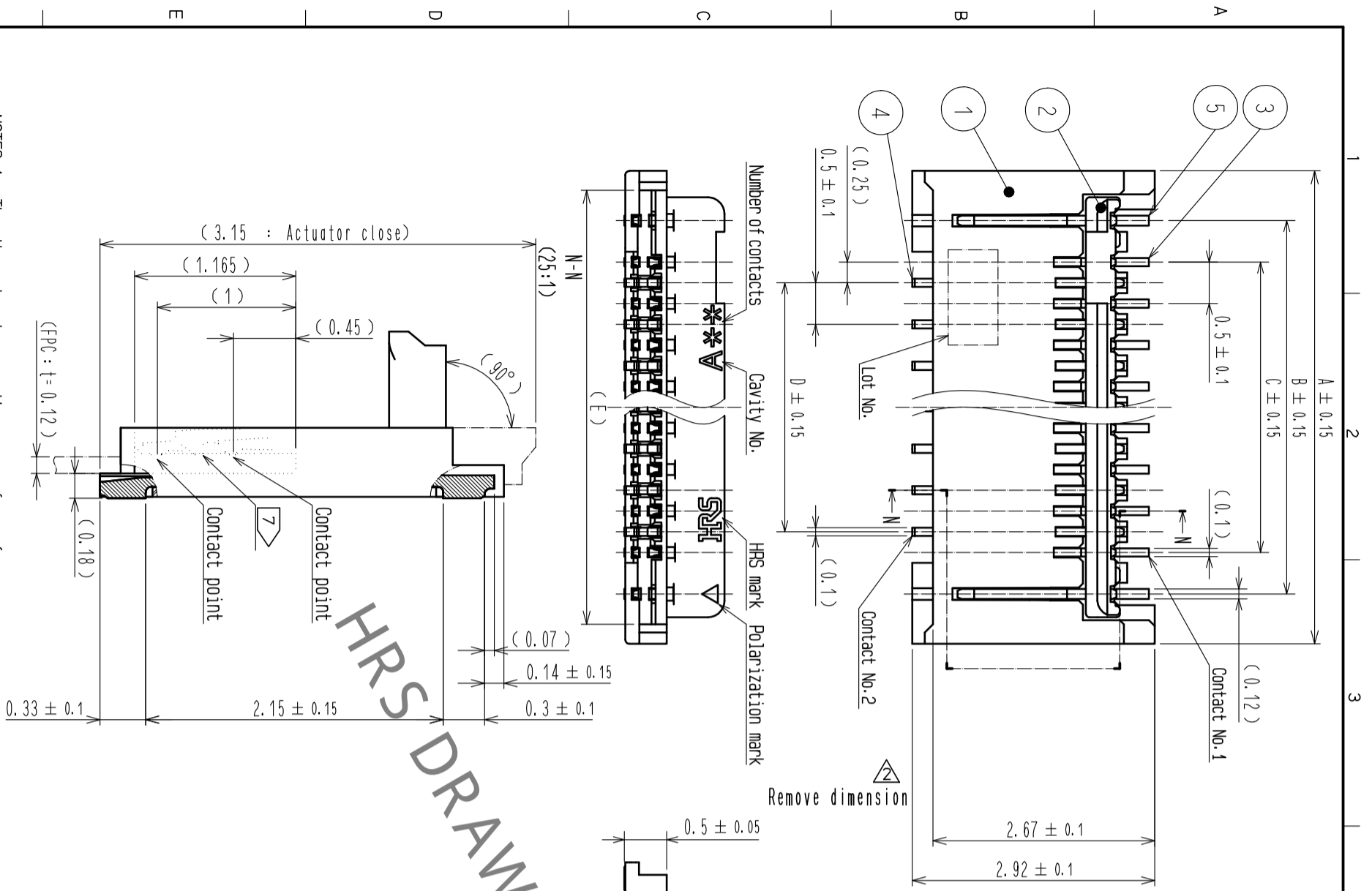

NOTES
 1. The dimension in parentheses are for reference.
 2. Lead co-planarity including reinforced chucking metals shall be 0.1 max.
 3. To be delivered with tape and reel packages.
 4. Note that preventive hole for sink mark or slit could be added for improvement.
 5. This product satisfies halogen free requirements defined as 900ppm maximum chlorine, 900ppm maximum bromine, and 1500ppm maximum total of chlorine and bromine.
 6. 900ppm maximum bromine, and 1500ppm maximum total of chlorine and bromine.
 7 Shows hook part of the chucking metal.

FORM HCO011-5-7

1	LCP	BETGE UL94V-0		5	PHOSPHOR BRONZE (CONTACT AREA LEAD) GOLD PLATING 0.03µm MIN OVER NICKEL 1µm MIN.	9	(CONNECTOR)		
2	PA	BLACK UL94V-0		6	PHOSPHOR BRONZE (CONTACT AREA LEAD) GOLD PLATING 0.03µm MIN OVER NICKEL 1µm MIN.	7	POLYSTYRENE		
3	PHOSPHOR BRONZE			7	PHOSPHOR BRONZE (CONTACT AREA LEAD) GOLD PLATING 0.03µm MIN OVER NICKEL 1µm MIN.	8	POLYSTYRENE		
4	PHOSPHOR BRONZE			8	PHOSPHOR BRONZE (CONTACT AREA LEAD) GOLD PLATING 0.03µm MIN OVER NICKEL 1µm MIN.				
MATERIAL		FINISH . REMARKS		NO.		MATERIAL		FINISH . REMARKS	
UNITS		SCALE		COUNT		DESCRIPTION OF REVISIONS		CHECKED	
mm		15 : 1		9		DIS-F-00006764		DATE	
HRS		HI ROSE ELECTRIC CO., LTD.		DRAWN		.RK. OGASAWARA		20170210	
				APPROVED		.NF. MIYAZAKI		20170210	
				CHECKED		.YH. MICHIDA		20170210	
				DESIGNED		.HY. YAMAZAKI		20170210	
				DRAWING		EDC-375451-99-00			
				PART		FH64MA- * S-0, 25SHW (99)			
				CODE		CL580-			

HRS DRAWING FOR REFERENCE

RECOMMENDED FPC (20:1)
 (Exposed conductor area thickness: t=0.12±0.02)

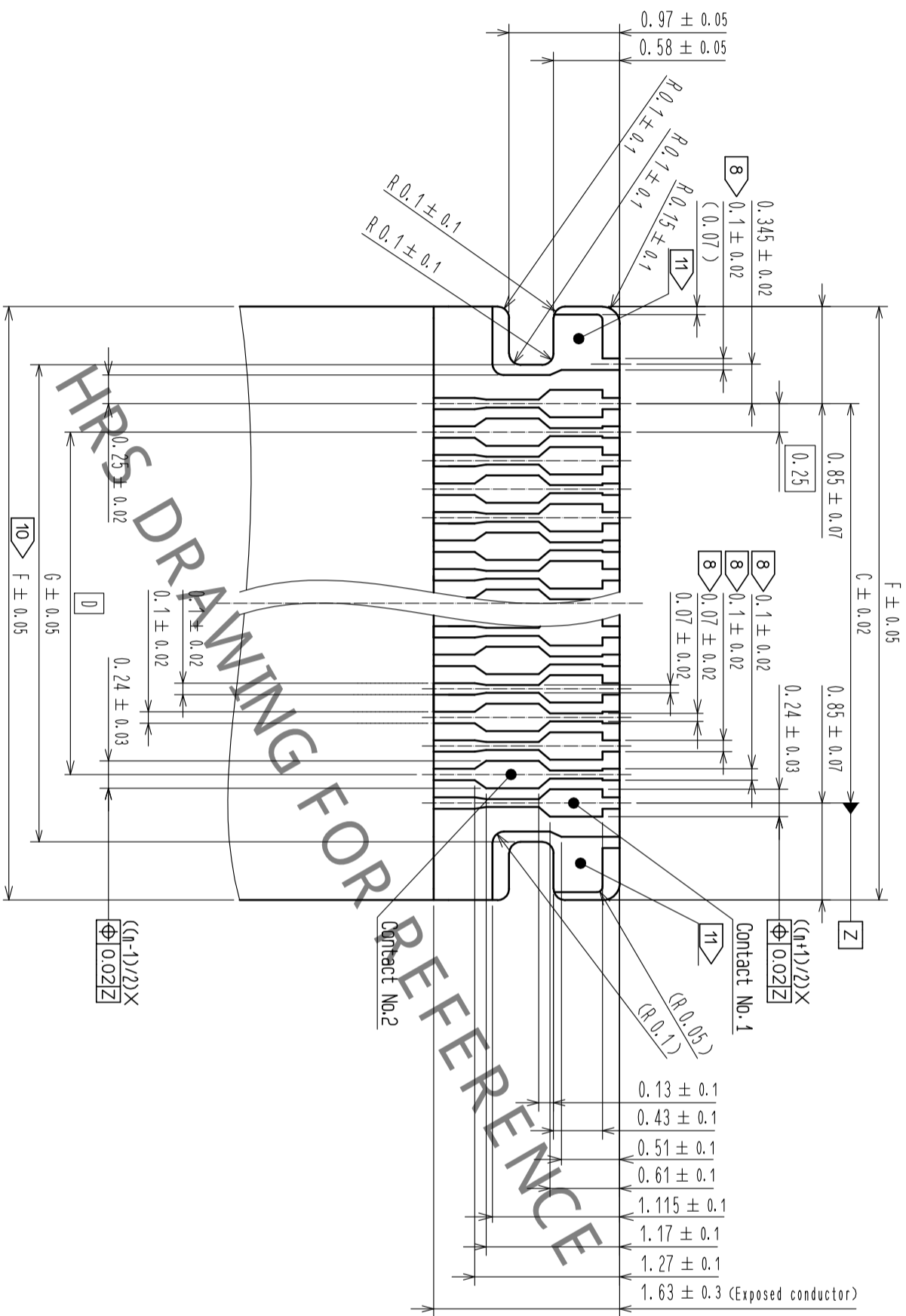

FPC CONFIGURATION (REFERENCE EXAMPLE)
 (FREE)

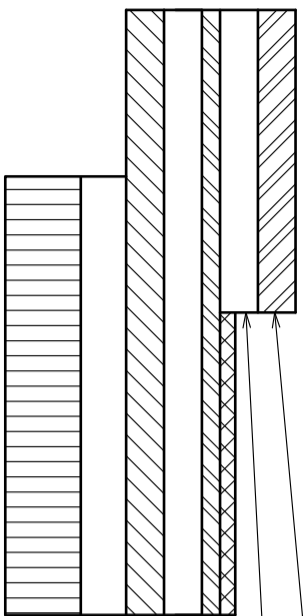

MATERIAL NAME	MATERIAL	THICKNESS (μm)
Covering film layer.	Polyimide 1mil	25
Cover adhesive		25
Surface treatment	1μm to 6μm nickel underplated 0.2μm gold plated	(4)
Copper foil	Cu 1/2 oz	18
Base adhesive	Heat-hardened adhesive	No adhesion material
Base film	Polyimide 1mil	25
Reinforcement material adhesive	Heat-hardened adhesive	30
Stiffener	Polyimide 2mil	50

NOTES 8 Shows recommended dimension when lead for plating is required.

9 Dimension P must be 0.5mm minimum.

10 Indicated tolerance is applicable to the exposed conductor.

11 Both end side of contact pad on FPC can not be used for signal transmission.

<RECOMMENDED FPC>

HR5	DRAWING NO.	EDC-375451-99-00
	PART NO.	FH64MA-**-S-0.25SHW(99)
	CODE NO.	CL580-

EMBOSSED CARRIER TAPE DIMENSION
 (5:1)

Direction of unreeling

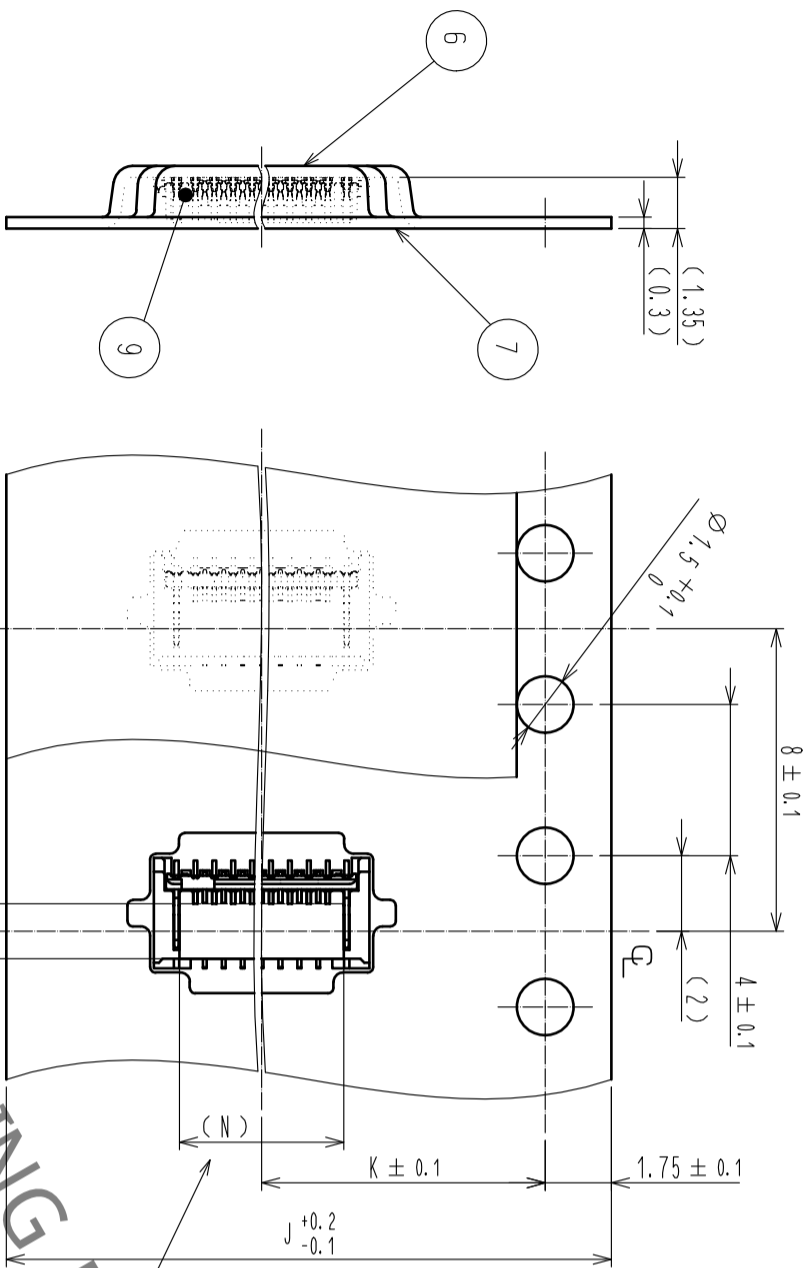

REEL DIMENSION
 (FREE)

Direction of unreeling

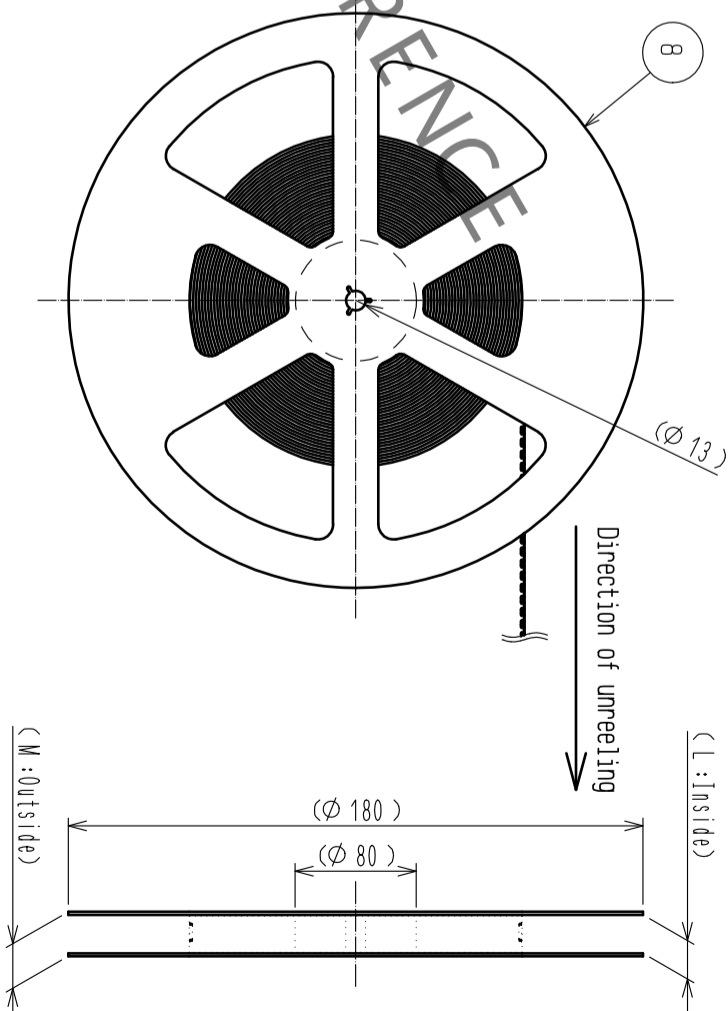

VACUUM PICK UP AREA

VACUUM PICK UP AREA

LEADER, TRAILER DIMENSION
 (FREE)

Direction of unreeling

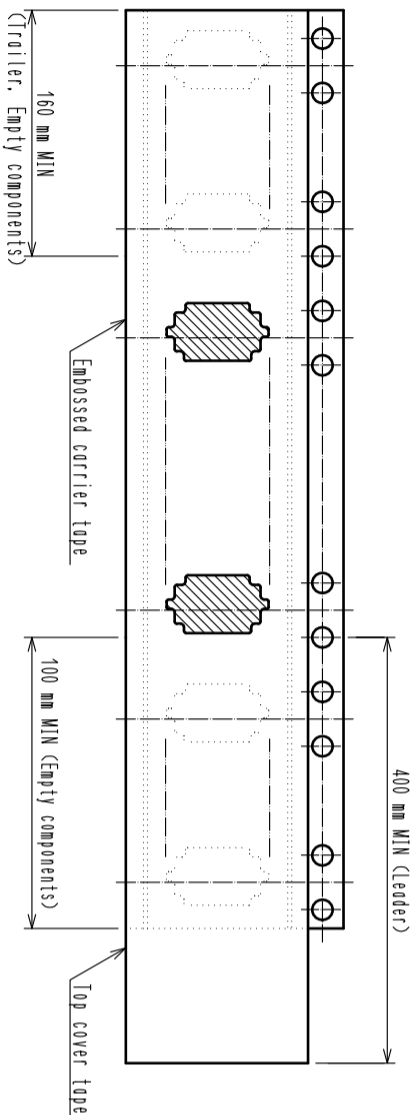

- NOTES 12. Per reel : 500 connectors.
 13. Refer to JIS C 0806 and IEC 60286-3
 (Packaging of components for automatic handling.)

<PACKING SPECIFICATIONS>

HR5	
DRAWING NO.	EDC-375451-99-00
PART NO.	FH64MA-**-S-0.25SHW(99)
CODE NO.	CL580-

PART NUMBER	CODE NUMBER	NUMBER OF CONTACTS	DIMENSION OF CONNECTOR, PCB MOUNTING PATTERN, STENCIL PATTERN, FPC										DIMENSION OF DRAWING FOR PACKING					
			A	B	C	D	E	F	G	J	K	L	M	N				
△ FH64MA-5S-0.25SHW(99)	CL580-4643-0-99	5	3.2	2	1	0.5	2.73	2.7	1.68	16	7.5	17.4	21.4	1.86				
FH64MA-7S-0.25SHW(99)	CL580-4610-0-99	7	3.7	2.5	1.5	1	3.23	3.2	2.18	16	7.5	17.4	21.4	2.36				
△ FH64MA-9S-0.25SHW(99)	-	9	4.2	3	2	1.5	3.73	3.7	2.68	16	7.5	17.4	21.4	2.86				
FH64MA-11S-0.25SHW(99)	CL580-4612-0-99	11	4.7	3.5	2.5	2	4.23	4.2	3.18	16	7.5	17.4	21.4	3.36				
FH64MA-13S-0.25SHW(99)	-	13	5.2	4	3	2.5	4.73	4.7	3.68	16	7.5	17.4	21.4	3.86				
FH64MA-15S-0.25SHW(99)	CL580-4608-0-99	15	5.7	4.5	3.5	3	5.23	5.2	4.18	16	7.5	17.4	21.4	4.36				
△ FH64MA-17S-0.25SHW(99)	-	17	6.2	5	4	3.5	5.73	5.7	4.68	16	7.5	17.4	21.4	4.86				
FH64MA-19S-0.25SHW(99)	CL580-4616-0-99	19	6.7	5.5	4.5	4	6.23	6.2	5.18	16	7.5	17.4	21.4	5.36				
FH64MA-21S-0.25SHW(99)	-	21	7.2	6	5	4.5	6.73	6.7	5.68	24	11.5	25.4	29.4	5.86				
△ FH64MA-23S-0.25SHW(99)	-	23	7.7	6.5	5.5	5	7.23	7.2	6.18	24	11.5	25.4	29.4	6.36				
△ FH64MA-25S-0.25SHW(99)	CL580-4642-0-99	25	8.2	7	6	5.5	7.73	7.7	6.68	24	11.5	25.4	29.4	6.86				
△ FH64MA-31S-0.25SHW(99)	-	31	9.7	8.5	7.5	7	9.23	9.2	8.18	24	11.5	25.4	29.4	8.36				

※ CONTACT POSITIONS WITHOUT CODE NUMBERS ARE CURRENTLY UNDER PLANNING.
 PLEASE CONTACT HIROSE FOR DETAILED INFORMATION ABOUT PRODUCT VARIATION.

<DIMENSION TABLE>

DRAWING NO.	EDC-375451-99-00
PART NO.	FH64MA-**-S-0.25SHW(99)
CODE NO.	CL580-



This connector features small and thin, requiring delicate and careful handling.
 To prevent connector/FPC breakage and contact failure (mating failure, FPC pattern breakage, etc.),
 read through the instructions shown below and handle the connector properly.

Connector Part Nomenclature

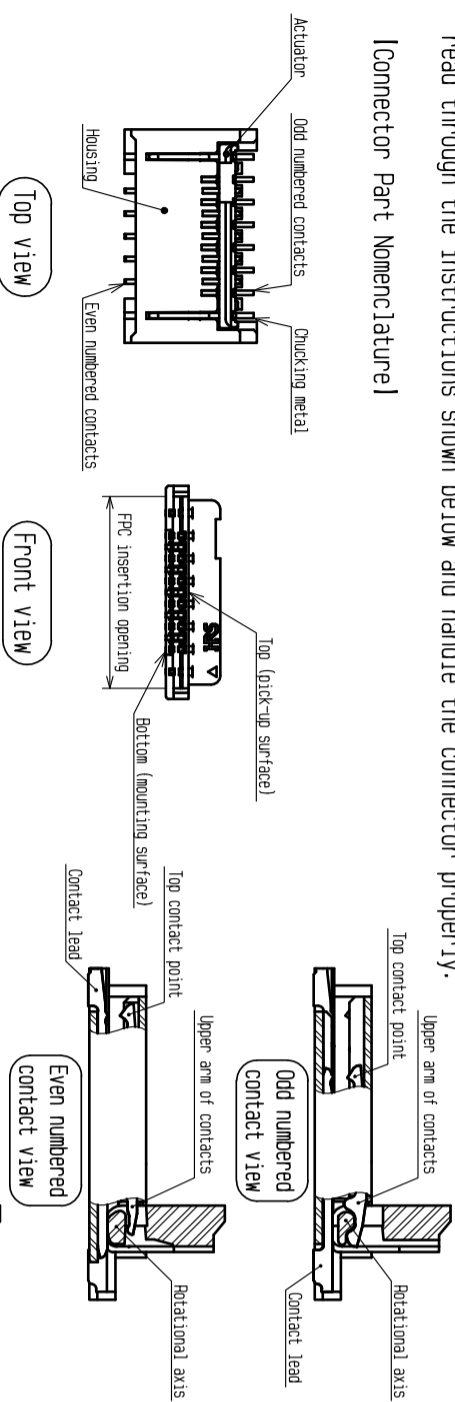

Operation and Precautions

1. Initial condition

Actuator does not have to be operated before inserting FPC, as the connector is delivered with the actuator opened.

[Caution]

- Do not close the actuator before inserting FPC. Closing the actuator without FPC could make the contact gap smaller, which could increase the FPC insertion force. (Example1)
- Do not insert FPC or operate actuator before mounting. (Example1)

Example1

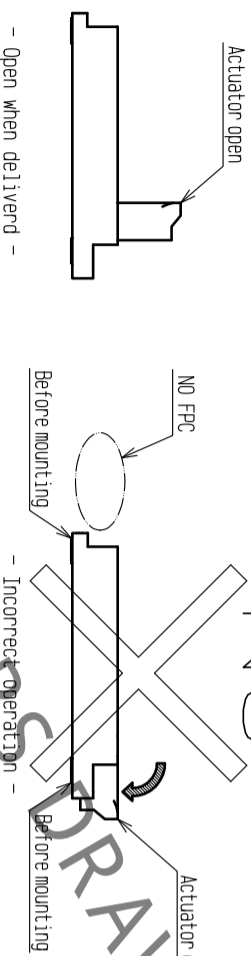

2. How to insert FPC

Insert the FPC into the connector opening horizontally to the PCB plane. Insert it properly to the very end. (Example2)

[Caution]

- Do not insert the FPC with the actuator closed. (Example3)
- Do not twist the FPC to up and down, right and left or an angle. (Example4)

Example2

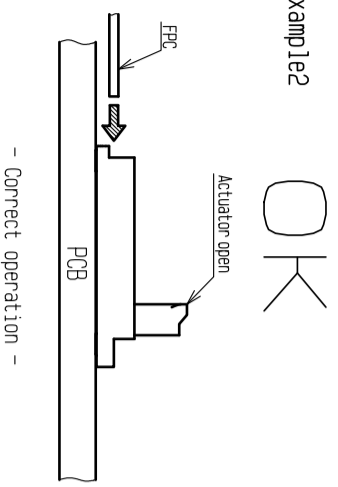

Example3

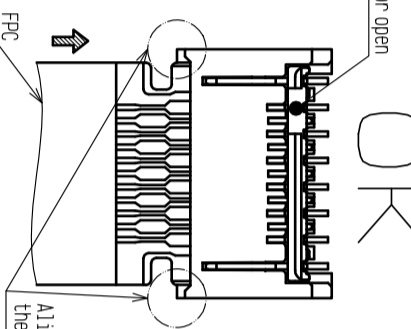

Example3

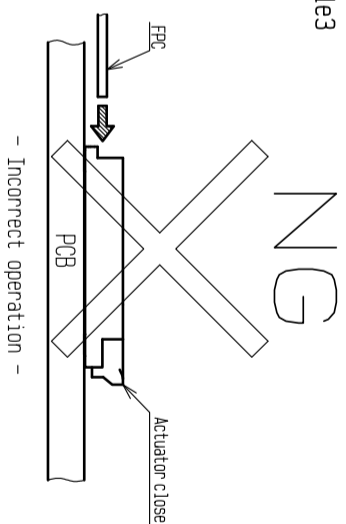

Example4

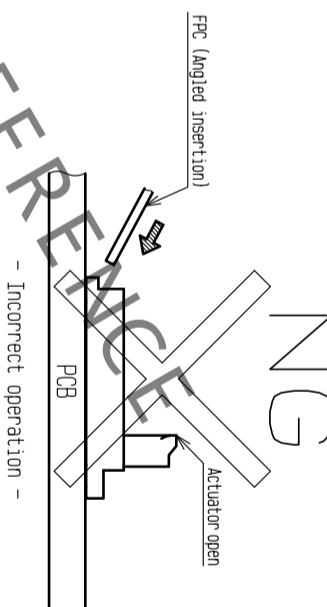

3. FPC insertion check

Make sure that the FPC tabs are located in proper position as shown in the figure below after FPC insertion. (Example5)

[Caution]

-Do not insert the FPC at an angle and/or stop it before insertion is completed. (Example6) (Example7)

Example5

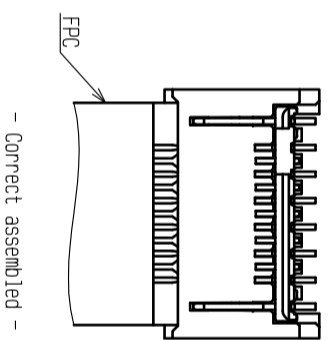

Example6

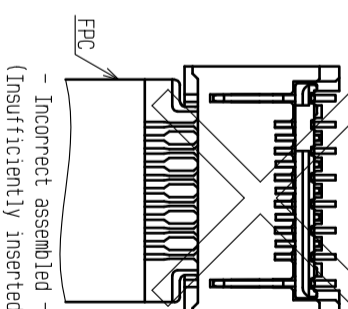

Example7

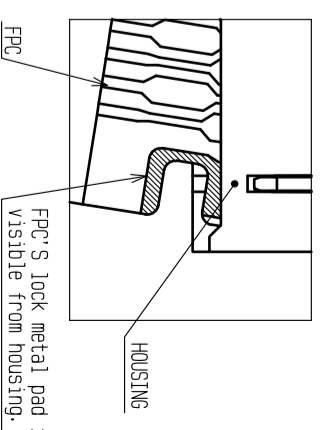
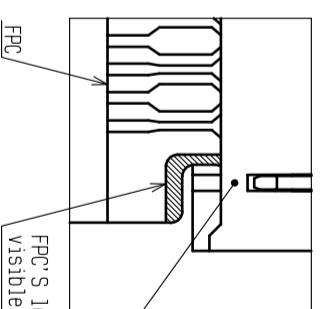
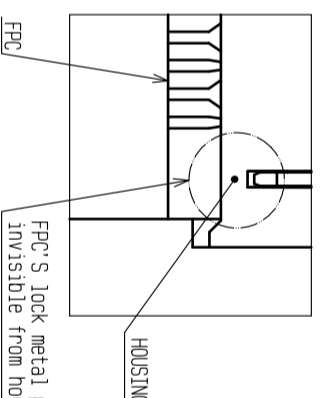
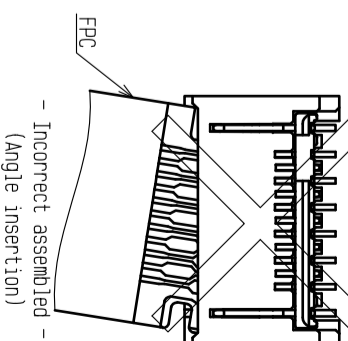

< INSTRUCTION MANUAL (1) >

HR5	
DRAWING NO.	EDC-375451-99-00
PART NO.	FH64MA-**-S-0.25SHW(99)
CODE	CL580-
NO.	2/5

4. How to Lock

The actuator rotates around the rotational axis as shown below.
Apply load to rotate the actuator by 90 degree after inserting the FPC. (Example18)

- [caution]
- To close the actuator, operate at the center of the actuator. (Example19)
 - To close the actuator, do not operate the actuator at one end only. (Example10)
 - Do not rotate the actuator to the counter direction. (Example11)
 - Do not push out the actuator horizontally. (Example12)
 - Do not push out the actuator vertically. (Example13)
 - Do not operate the actuator while the upper contact arm is pressed down. (Example14)
 - Do not pick the actuator to lift. (Example15)
 - Operate the actuator by hand without using sharp tool such as Tweezers. (Example16)
 - Do not apply excess force to the housing during the operation. (Example17)

Example18 [Actuator movable range] (Side view)

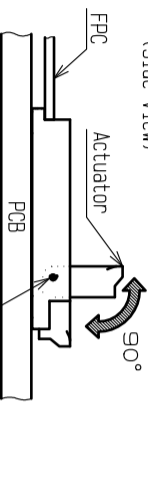

Example9 OK

Close the actuator at the center

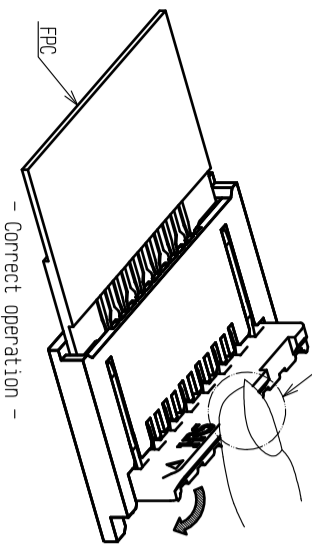

- Correct operation -

Example11 N/G

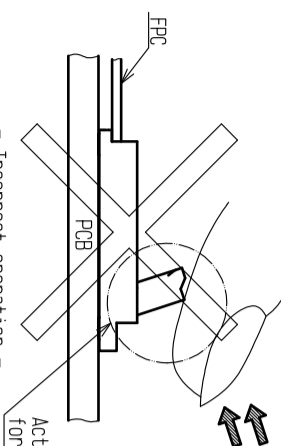

- Incorrect operation -

Example12 N/G



- Incorrect operation -

Example13 N/G

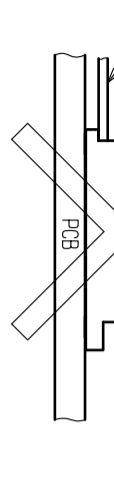

- Incorrect operation -

Example10 N/G

Do not operate the actuator at one end only

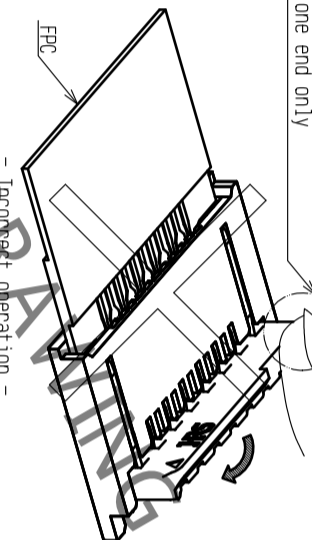

- Incorrect operation -

Example12 N/G

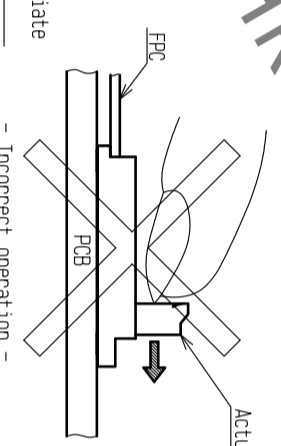

- Incorrect operation -

Example14 N/G

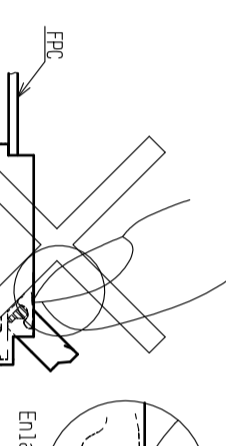

Upper arm of contact is locked and unable to displace.

- Incorrect operation -

Example15

N/G

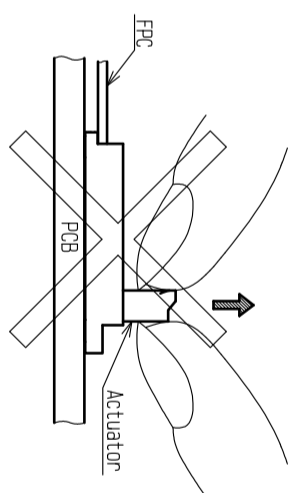

- Incorrect operation -

Example16

N/G

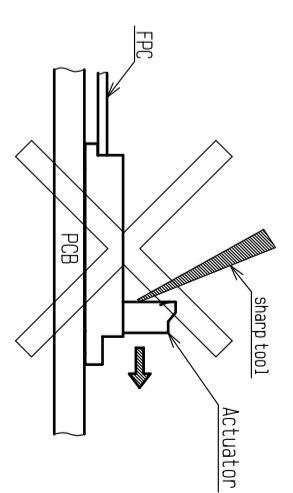

- Incorrect operation -

Example17

Do not apply excess force to the housing during the operation.

N/G

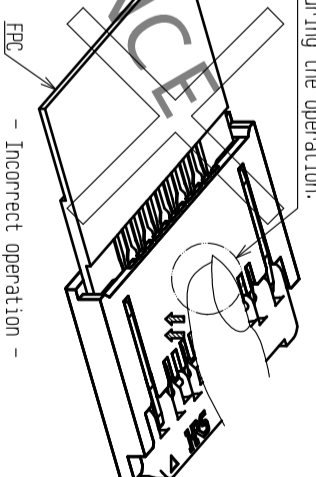

- Incorrect operation -

Example18

N/G

5. Mating confirmation of the FPC
Visually confirm the FPC positioning after closing the actuator. (Example18)

[Caution]

-Do not insert the FPC at an angle and/or stop it before insertion is completed. (Example19) (Example20)

Example18

OK

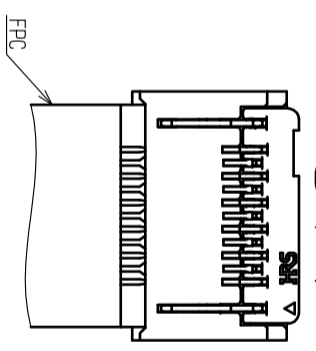

- Correct assembled -

Example19

N/G

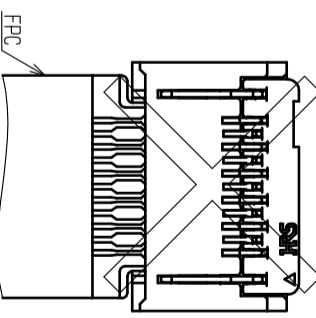

- Incorrect assembled - (Insufficiently inserted)

Example20

N/G

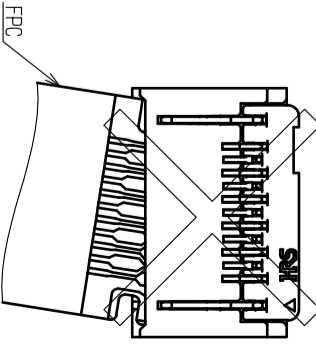

- Incorrect assembled - (Angle insertion)

<INSTRUCTION MANUAL (2)>

HRS	
DRAWING NO.	EDC-375451-99-00
PART NO.	FH64MA-**-S-0.25SHW(99)
CODE	CL580-
NO.	2/6

6. How to unlock

Slowly flip up the actuator to release the lock. (Example21)

[Caution]

- To open the actuator, operate at the center of the actuator. (Example22)
- To open the actuator, do not operate the actuator at one end only. (Example23)
- The actuator is opened up to the movable limit, 90 degree. (Example24)
- Do not open the actuator beyond the specified degree or apply excess force to the actuator.
- Open the actuator right above.
- Do not attempt to open further or to open it by applying horizontal force as this may cause its damage. (Example25)
- Do not pick the actuator to lift. (Example26)
- Operate the actuator by hand without using sharp tool such as Tweezers. (Example27)
- Do not apply excess force to the housing during the operation. (Example28)
- Please note that the connector is back flip style connector, and the opening for FPC insertion and the actuator face the opposite direction.
- Do not try to lift the actuator at the FPC insertion opening side. (Example29)

Example21

OK

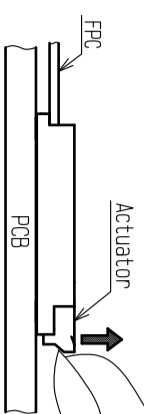

Example22

OK

Open the actuator at the center

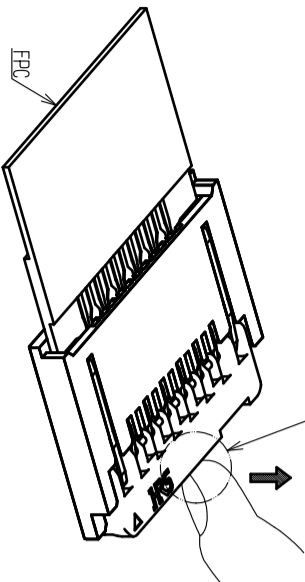

- Correct operation -

Example23

NG

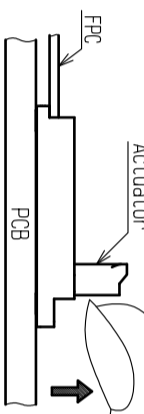

- Correct operation -

Do not operate the actuator at one end only

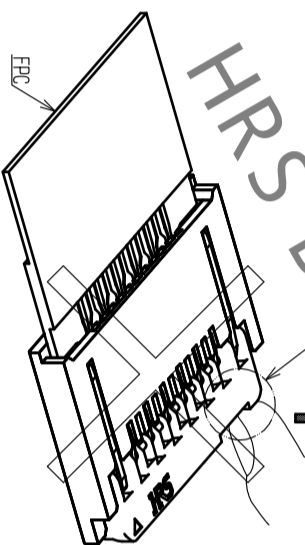

- Incorrect operation -

Example25

NG

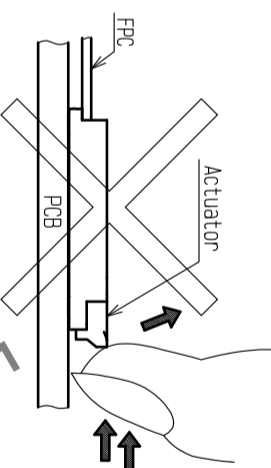

- Incorrect operation -

Example26

NG

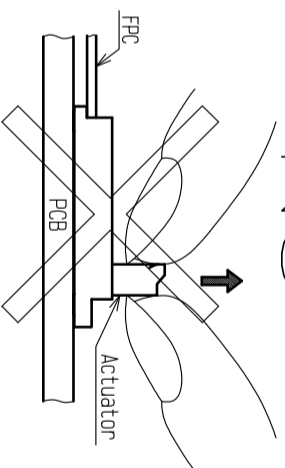

- Incorrect operation -

Example28

NG

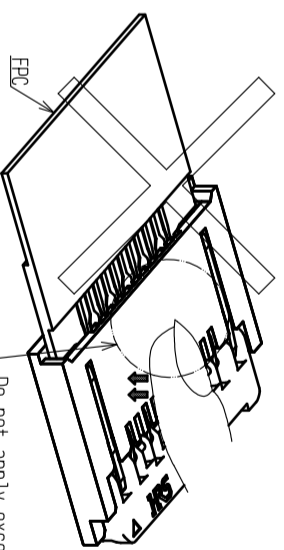

- Incorrect operation -

Do not apply excess force to the housing during the operation.

Example27

NG

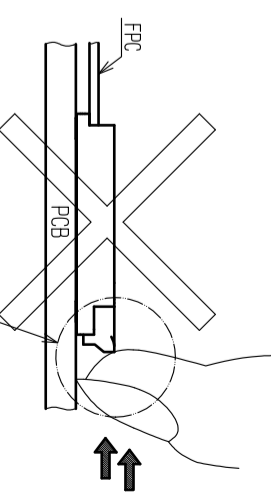

- Incorrect operation -

Actuator is pushed into connector

Example29

NG

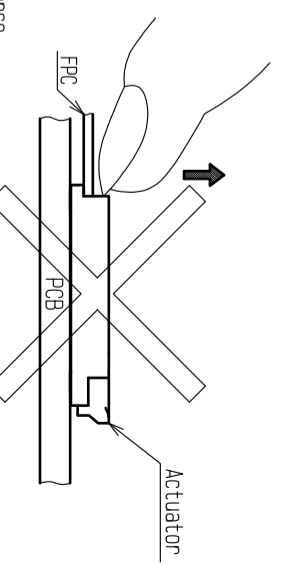

- Incorrect operation -

Example24

NG

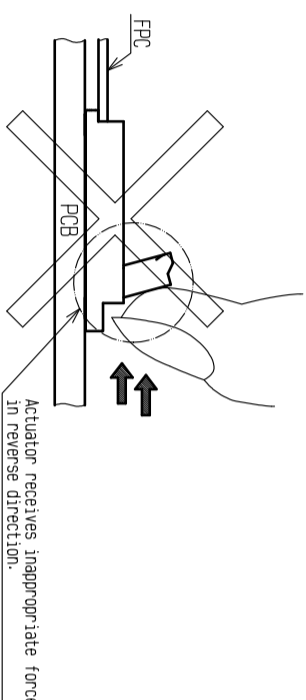

- Incorrect operation -

Actuator receives inappropriate force in reverse direction.

< INSTRUCTION MANUAL (3) >

HRS	
DRAWING NO.	EDC-375451-99-00
PART NO.	FH64MA-**-S-0.25SHW(99)
CODE	CL580-
NO.	2/7

7. How to remove FPC

After rotating the actuator to the fully opened position carefully withdraw the FPC pulling out horizontally. (Example30)

[Caution]
 -For FPC removal, do not pull out the FPC upward or angled direction. (Example31)
 -Do not attempt to pull the FPC without unlocking the actuator. (Example32).

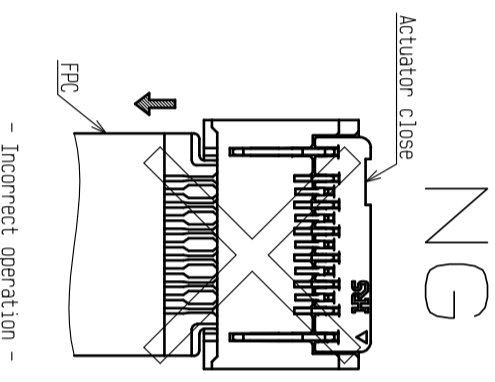
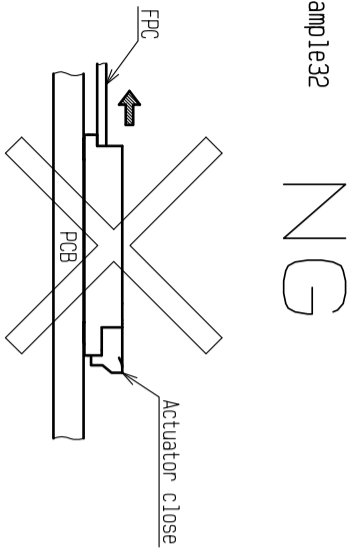
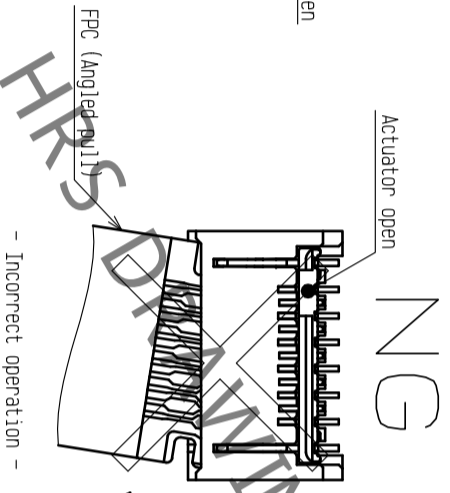
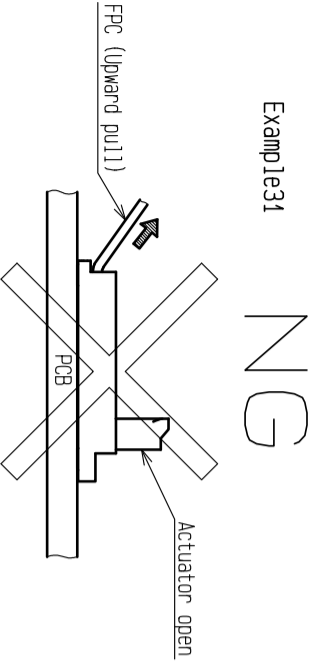
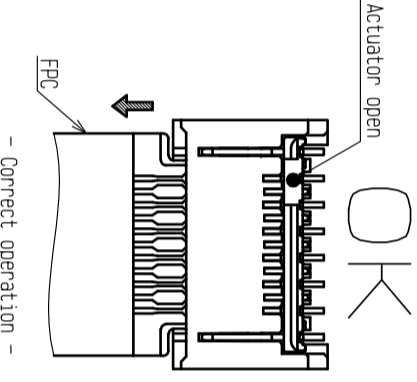
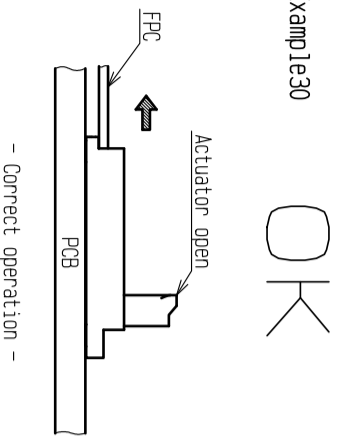

[Precautions for component layout]

Depending on a FPC rounding, a load is applied to the connector, and a contact failure may occur. To prevent a failure, take the following notes into a consideration during mechanism design.

[Caution]
 -Avoid applying forces to FPC in vertical or horizontal directions. (Example33) (Example35)
 In addition, avoid pulling up and down on the FPC.
 -When fixing FPC after FPC cabling, avoid pulling FPC, and route the wire FPC with slack.
 In this regard, the stiffener is parallel to the PCB. (Example34)
 -During FPC wiring, ensure that stress is not applied directly to the connector.
 Do not bend the FPC excessively near the connector during use, or it may cause contact failure or FPC breakage.
 Stabilizing the FPC is recommended. (Example35)
 -Do not mount other components touching to the FPC underneath the FPC stiffener. (Example36)
 -Make adjustments with the FPC manufacturer for FPC bending performance and wire breakage.
 -Keep a sufficient FPC insertion space in the stage of the layout in order to avoid incorrect FPC insertion.
 -Appropriate FPC length and component layout are recommended for assembly ease.
 -Too short FPC length makes assembly difficult.
 -Keep spaces for the actuator movement and its operation for PCB design and component layout.

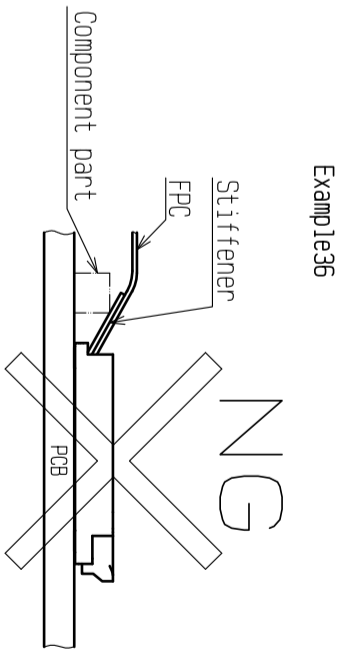
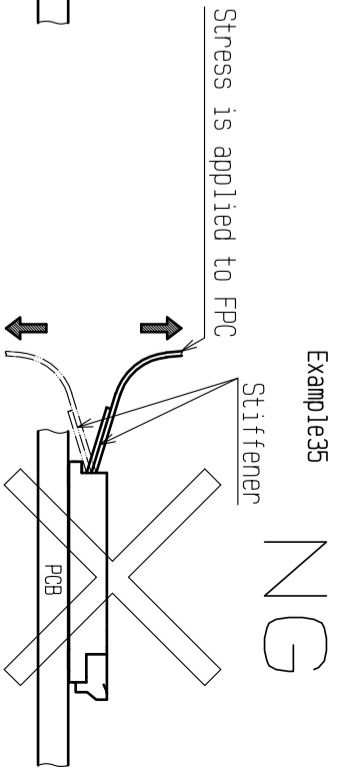
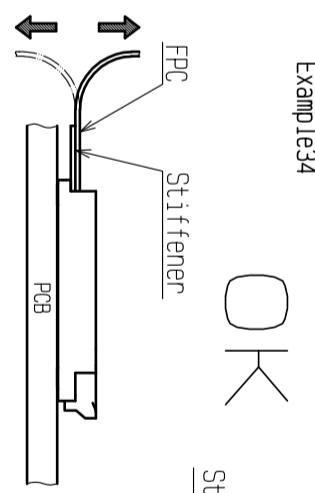
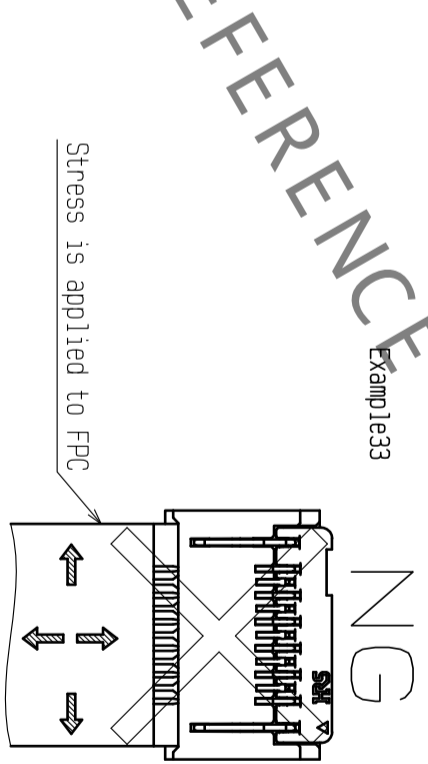

<< INSTRUCTION MANUAL (4) >>

HRS	
DRAWING NO.	EDC-375451-99-00
PART NO.	FH64MA-**-S-0.25SHW(99)
CODE	CL580-
NO.	2/8

[Instructions for mounting on the PCB]

Follow the instructions shown below when mounting on the PCB.

[Caution]

- Refer to recommended layouts on the page 1 for PCB and stencil pattern.
- Shorter pattern width than the recommended PCB dimension could cause solder wicking and/or flux penetration.
- Larger pattern than the recommended stencil dimension could cause solder wicking and/or flux penetration.
- Clearance underneath the contact and the housing is very small. In case solder resist and/or silk screening are applied on PCB underneath the connector, verify the thickness, or it could push up the connector bottom and may cause soldering defect and/or insufficient fillet formation.
- Apply reflow temperature profile within the specified conditions. In individual applications, the actual temperature may vary, depending on solder paste type, volume/thickness and PCB size/thickness.
- Consult your solder paste and equipment manufacturer for specific recommendations.
- Prevent warpage of PCB, where possible, since it can cause soldering failure even with 0.1 mm max coplanarity.
- When mounting on the flexible board, please make sure to put a stiffener on the backside of the flexible board.
- We recommend a glass epoxy material with the thickness of 0.3 mm min.
- Do not add 0.5 N or greater external force when unree! or pick and place the connector etc, or it may get broken.

[Instructions for PCB handling after mounting the connector]

Follow the instructions shown below when mounting on the PCB.

[Caution]

- Splitting a large PCB into several pieces
 - Screwing the PCB
- Avoid the handling described above so that no force is exerted on the PCB during the assembly process. Otherwise, the connector may become defective.
- The warp of a 100 mm wide PCB should be 0.5 mm or less.
- The warp of PCB suffers stress on connector and the connector may become defective. (Example 37)

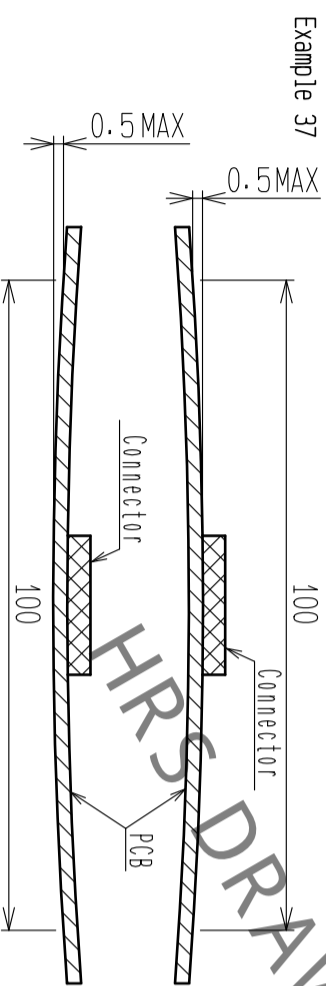

[Instructions on manual soldering]

Follow the instructions shown below when soldering the connector manually during repair work, etc.

[Caution]

- Do not perform manual soldering with the FPC inserted into the connector.
- Do not heat the connector excessively. Be very careful not to let the soldering iron contact any parts other than connector leads. Otherwise, the connector may be deformed or melt.
- Do not supply excessive solder (or flux).
- If excessive solder (or flux) is supplied on the terminals or chucking metals, solder or flux may adhere to the contacts or rotating parts of the actuator, resulting in poor contact or a rotation failure of the actuator.
- Supplying excessive solder to the chucking metals may hinder actuator rotation, resulting in breakage of the connector.

△ [Recommended reflow temperature profile]

The temperatures mentioned above refer to the PCB surface temperature near the connector leads. In individual applications the actual temperature may vary, depending on solder paste type, volume/thickness and board size/thickness.

Reflow method: IR reflow
 Number of reflow cycles: 2 cycles MAX.

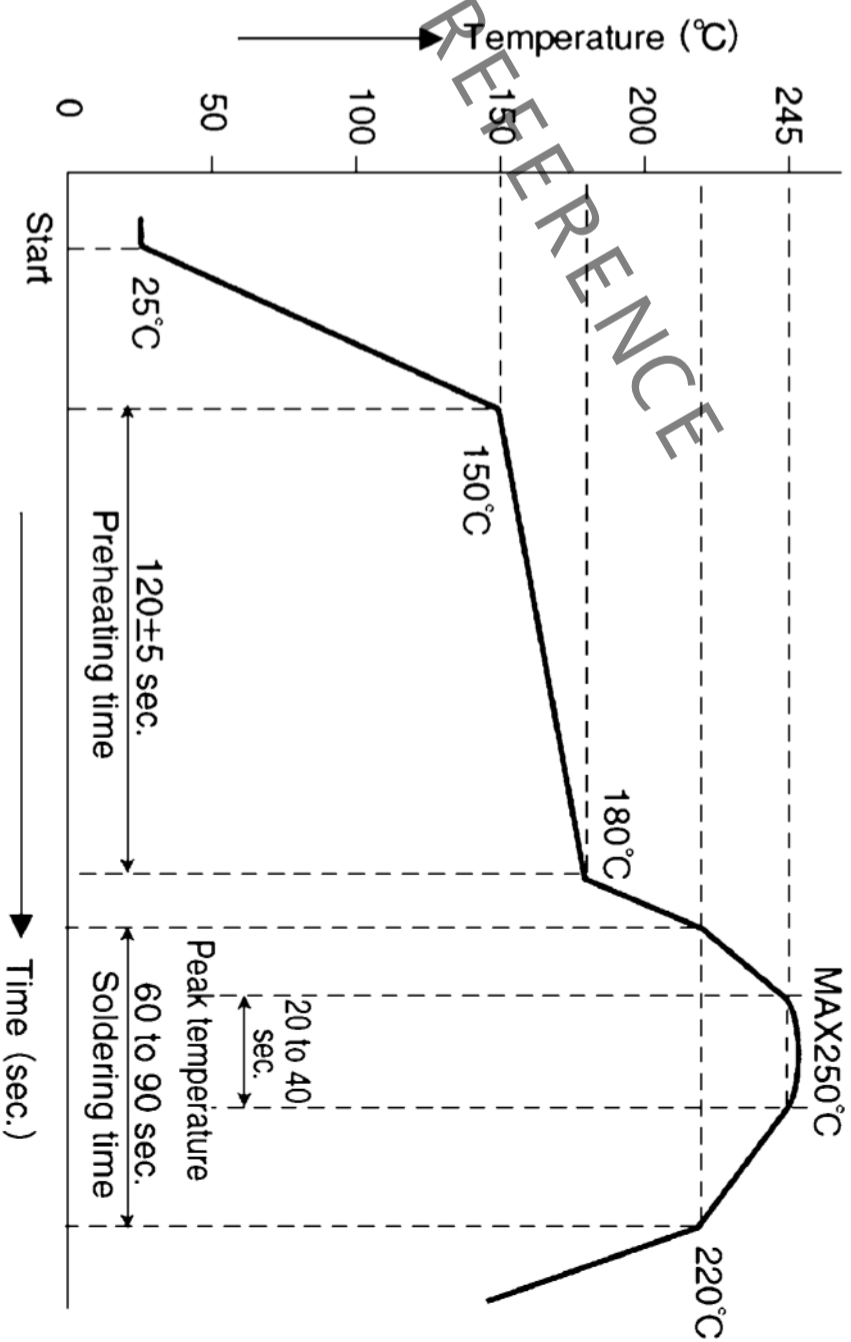

< INSTRUCTION MANUAL (5) >

HRS	
DRAWING NO.	EDC-375451-99-00
PART NO.	FH64MA-**-S-0.25SHW(99)
CODE NO.	CL580-
2/9	