

## Automotive door actuator driver

### Datasheet - production data

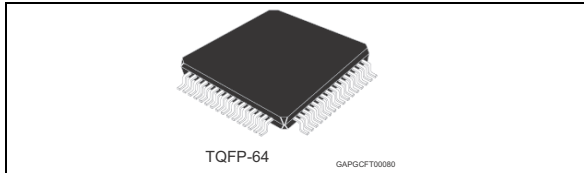

### Features



- AEC-Q100 qualified
- One full bridge for 6 A load ( $R_{ON} = 150 \text{ m}\Omega$ )
- Two half bridges for 3 A load ( $R_{ON} = 300 \text{ m}\Omega$ )
- Two half bridges for 0.5 A load ( $R_{ON} = 1600 \text{ m}\Omega$ )
- One high-side driver for 5 A load ( $R_{ON} = 100 \text{ m}\Omega$ )
- One configurable high-side driver for up to 1.5 A ( $R_{ON} = 500 \text{ m}\Omega$ ) or 0.35 A ( $R_{ON} = 1600 \text{ m}\Omega$ ) load
- One configurable high-side driver for 0.7 A ( $R_{ON} = 800 \text{ m}\Omega$ ) or 0.35 A ( $R_{ON} = 1600 \text{ m}\Omega$ ) load
- Two high-side drivers for 0.5 A load ( $R_{ON} = 1600 \text{ m}\Omega$ )
- Programmable softstart function to drive loads with higher inrush currents as current limitation value
- Very low  $V_S$  current consumption in standby mode ( $I_S < 6 \mu\text{A typ}$ ;  $T_j \leq 85 \text{ }^\circ\text{C}$ )
- Current monitor output for all high-side drivers
- Central two-stage charge pump
- Motor bridge driver with full  $R_{dson}$  down to 6 V
- Device contains temperature warning and protection
- Open-load detection for all outputs
- Overcurrent protection for all outputs
- Separated half bridges for door lock motor
- Programmable PWM control of all outputs

- STM standard serial peripheral interface (ST-SPI 3.1)
- Control block for electrochromic element
- Electrochromic element can be negatively discharged
- Prepared for additional fail-safe path for H-bridge

### Applications

- Door actuator driver with 6 bridges for double door lock control, mirror fold and mirror axis control, high-side driver for mirror defroster, bulbs and LEDs.
- Control block with external MOS transistor for charging / discharging of electrochromic glass. Motor bridge driver.
- H-bridge control for external power transistors

### Description

The L99DZ80EP is a microcontroller driven multifunctional door actuator driver for automotive applications. Up to five DC motors and five grounded resistive loads can be driven with six half bridges and five high-side drivers. Four external MOS transistors in bridge configuration can be driven. An electrochromic mirror glass can be controlled using the integrated SPI-driven module in conjunction with an external MOS transistor. The mirror glass can also be discharged through a negative supply. The integrated SPI controls all operating modes (forward, reverse, brake and high impedance). All diagnostic information is available via SPI read.

**Table 1. Device summary**

Package	Order codes	
	Tray	Tape and reel
TQFP-64	L99DZ80EP	L99DZ80EPTR

# Contents

- 1        Block diagram and pin description ..... 7**
  
- 2        Electrical specifications ..... 11**
  - 2.1    Absolute maximum ratings .....11
  - 2.2    ESD protection ..... 12
  - 2.3    Thermal data ..... 12
  - 2.4    Package and PCB thermal data ..... 13
    - 2.4.1    TQFP-64 thermal data ..... 13
  - 2.5    Electrical characteristics ..... 15
  - 2.6    Outputs OUT1 - OUT11, ECV, ECFD ..... 17
  - 2.7    H-bridge driver ..... 21
  - 2.8    Electrochrome mirror driver ..... 25
  - 2.9    SPI / logic – electrical characteristics ..... 27
  
- 3        Application information ..... 32**
  - 3.1    Dual power supply: VS and VCC ..... 32
  - 3.2    Wake up and Active mode/standby mode ..... 32
  - 3.3    Charge pump ..... 32
  - 3.4    Diagnostic functions ..... 32
  - 3.5    Overvoltage and undervoltage detection at VS ..... 33
  - 3.6    Overvoltage and undervoltage detection at VCC ..... 33
  - 3.7    Temperature warning and shutdown ..... 33
  - 3.8    Inductive loads ..... 34
  - 3.9    Open-load detection ..... 34
  - 3.10    Overcurrent detection ..... 34
  - 3.11    Current monitor ..... 34
  - 3.12    PWM mode of the power outputs ..... 34
  - 3.13    Cross-current protection ..... 35
  - 3.14    Programmable soft-start function to drive loads with higher inrush current .  
35
  - 3.15    H-bridge control (DIR, PWMH, bits SD, SDS) ..... 36
  - 3.16    H-bridge driver slew-rate control ..... 37

3.17	Resistive low	38
3.18	Short circuit detection/drain source monitoring	38
3.19	H-bridge monitoring in off-mode	39
3.20	Programmable cross current protection	41
3.21	Controller of electrochromic glass	42
3.22	Watchdog	44
<b>4</b>	<b>Functional description of the SPI</b>	<b>45</b>
4.1	General description	45
4.1.1	Chip Select Not (CSN)	45
4.1.2	Serial Data In (DI)	45
4.1.3	Serial Clock (CLK)	45
4.1.4	Serial Data Out (DO)	45
4.1.5	SPI communication flow	45
4.2	Command byte	47
4.2.1	Operation code definition	47
4.3	Device memory map	47
<b>5</b>	<b>SPI - control and status registers</b>	<b>49</b>
5.1	Control Register 0	50
5.2	Control Register 1	50
5.3	Control Register 2	51
5.4	Control Register 3	52
5.5	Control Register 4	53
5.6	Control Register 5	53
5.7	Control Register 6	54
5.8	Configuration Register	55
5.9	Status Register 0	55
5.10	Status Register 1	56
5.11	Status Register 2	57
5.12	Status Register 3	57
<b>6</b>	<b>Package and packing information</b>	<b>59</b>
6.1	ECOPACK <sup>®</sup> package	59
6.2	TQFP-64 mechanical data	59

---

6.3	TQFP-64 packing information .....	61
<b>7</b>	<b>Revision history .....</b>	<b>65</b>

## List of tables

Table 1.	Device summary . . . . .	1
Table 2.	Pin definitions and functions . . . . .	8
Table 3.	Absolute maximum ratings . . . . .	11
Table 4.	ESD protection . . . . .	12
Table 5.	Operating junction temperature . . . . .	12
Table 6.	Temperature warning and thermal shutdown . . . . .	12
Table 7.	Package thermal impedance . . . . .	12
Table 8.	Supply . . . . .	15
Table 9.	Overvoltage and undervoltage detection . . . . .	15
Table 10.	Current monitor output (CM) . . . . .	16
Table 11.	Charge pump . . . . .	16
Table 12.	On-resistance . . . . .	17
Table 13.	Power outputs switching times . . . . .	19
Table 14.	Current monitoring . . . . .	19
Table 15.	Gate drivers for the external Power-MOS (H-bridge) . . . . .	21
Table 16.	Gate drivers for the external Power-MOS switching times . . . . .	21
Table 17.	Drain source monitoring . . . . .	24
Table 18.	Open-load monitoring . . . . .	25
Table 19.	Electrochrome mirror driver . . . . .	25
Table 20.	Delay time from Standby to Active mode . . . . .	27
Table 21.	Inputs: DI, CSN, CLK, DIR and PWMH . . . . .	27
Table 22.	AC-Characteristics . . . . .	28
Table 23.	Dynamic characteristics . . . . .	28
Table 24.	Watchdog . . . . .	31
Table 25.	H-bridge control truth table . . . . .	36
Table 26.	H-bridge DS-monitor threshold . . . . .	39
Table 27.	Cross-current protection time . . . . .	42
Table 28.	Command byte . . . . .	47
Table 29.	Operation code definition . . . . .	47
Table 30.	RAM memory map . . . . .	47
Table 31.	ROM memory map . . . . .	48
Table 32.	Global status byte . . . . .	49
Table 33.	Control Register 0 . . . . .	50
Table 34.	Control Register 1 . . . . .	50
Table 35.	Control Register 2 . . . . .	51
Table 36.	Control Register 3 . . . . .	52
Table 37.	Control Register 4 . . . . .	53
Table 38.	Control Register 5 . . . . .	53
Table 39.	Control Register 6 . . . . .	54
Table 40.	Configuration Register . . . . .	55
Table 41.	Status Register 0 . . . . .	55
Table 42.	Status Register 1 . . . . .	56
Table 43.	Status Register 2 . . . . .	57
Table 44.	Status Register 3 . . . . .	57
Table 45.	TQFP-64 mechanical data . . . . .	59
Table 46.	Document revision history . . . . .	65

## List of figures

Figure 1.	Block diagram . . . . .	7
Figure 2.	Pin connection (top view) . . . . .	10
Figure 3.	TQFP-64 2 layer PCB . . . . .	13
Figure 4.	TQFP-64 4 layer PCB . . . . .	13
Figure 5.	TQFP-64 thermal impedance junction to ambient vs PCB copper area . . . . .	14
Figure 6.	IGHxr ranges . . . . .	23
Figure 7.	IGHxf ranges . . . . .	23
Figure 8.	H-driver delay times . . . . .	24
Figure 9.	SPI timing parameters . . . . .	29
Figure 10.	SPI input and output timing parameters . . . . .	30
Figure 11.	SPI delay description . . . . .	30
Figure 12.	Power-output (OUT<11:1>, ECV, ECFD) timing. . . . .	31
Figure 13.	Overcurrent recovery mode . . . . .	36
Figure 14.	H-bridge GSHx slope . . . . .	38
Figure 15.	H-bridge diagnosis . . . . .	39
Figure 16.	H-bridge open-load detection (no open-load detected) . . . . .	40
Figure 17.	H-bridge open-load detection (open-load detected) . . . . .	40
Figure 18.	H-bridge open-load detection (short to ground detected) . . . . .	41
Figure 19.	H-bridge open-load detection with H-OLTH HIGH = '1' (short to $V_S$ detected) . . . . .	41
Figure 20.	Electrochrome mirror driver with mirror referenced to ground . . . . .	43
Figure 21.	Electrochrome mirror driver with mirror referenced to ECFD for negative discharge . . . . .	44
Figure 22.	Write and read SPI . . . . .	46
Figure 23.	TQFP-64 package dimension . . . . .	60
Figure 24.	TQFP-64 power lead-less tray shipment (no suffix) (part 1) . . . . .	61
Figure 25.	TQFP-64 power lead-less tray shipment (no suffix) (part 2) . . . . .	62
Figure 26.	TQFP-64 power lead-less tape and reel shipment (suffix "TR") (part 1) . . . . .	63
Figure 27.	TQFP-64 power lead-less tape and reel shipment (suffix "TR") (part 2) . . . . .	64



Table 2. Pin definitions and functions

Pin	Symbol	Function
57, 58	GND <sub>1</sub>	Ground: reference potential. GND1 and GND2 are internally connected. GND1 supplies OUT1-3, GND2 supplies OUT4-6
17, 18, 26, 31, 32	GND <sub>2</sub>	Important: For the capability of driving the full current at the outputs, all pins of GND must be externally connected!
17	SGND	Signal Ground: this pin is shared with GND2 pin
2, 3, 45, 46, 51, 52	VS <sub>1</sub>	Power supply voltage for power stage outputs (external reverse protection required): for this input a ceramic capacitor as close as possible to GND is recommended. VS1 supplies OUT1-3, OUT7-11 and the internal VS supply, VS2 supplies OUT4-6
11, 12, 23, 36, 37	VS <sub>2</sub>	Important: For the capability of driving the full current at the outputs all pins of VS must be externally connected!
48, 49, 50	OUT11	High-side-driver output 11: the output is built by a high-side switch and is intended for resistive loads, hence the internal reverse diode from GND to the output is missing. For ESD reason a diode to GND is present but the energy which can be dissipated is limited. The High-side driver is a power DMOS transistor with an internal parasitic reverse diode from the output to VS (bulk-drain-diode). The output is overcurrent and open load protected.  Important: For the capability of driving the full current at the outputs all pins of OUT11 must be externally connected!
59, 60	OUT1	Half-bridge outputs 1,2,3,4,5,6: the output is built by a high side and a low side switch, which are internally connected. The output stage of both switches is a power DMOS transistor. Each driver has an internal parasitic reverse diode (bulk-drain-diode: high side driver from output to VS, low side driver from GND to output). This output is over current and open load protected.
56	OUT2	
55	OUT3	
19, 20, 21, 22	OUT4	
27, 28, 29, 30	OUT5	
24, 25	OUT6	
40	DO	Serial data output: the diagnosis data is available via the SPI and this 3-state-output. The output remains in 3-state, if the chip is not selected by the input CSN (CSN = high).
34	CM	Current monitor output: depending on the selected multiplexer bits of the Control Register this output sources an image of the instant current through the corresponding high side driver with a fixed ratio.
35	CSN	Chip-Select-Not input: this input is low active and requires CMOS logic levels. The serial data transfer between the device and the micro controller is enabled by pulling the input CSN to low level.
41	DI	Serial data input: the input requires CMOS logic levels and receives serial data from the microcontroller. The data is a 24 bit control word and the most significant bit (MSB, bit 23) is transferred first.
38	CLK	Serial clock input: this input controls the internal shift register of the SPI and requires CMOS logic levels.
33	DIR	Direction Input: this input controls the H-Bridge Drivers



Table 2. Pin definitions and functions (continued)

Pin	Symbol	Function
39	VCC	Supply Voltage: 5 V supply. A ceramic capacitor as close as possible to GND is recommended.
44	OUT9	High-side-driver output 9: the output is built by a high side switch and is intended for resistive loads; hence the internal reverse diode from GND to the output is missing. For ESD reason a diode to GND is present but the energy which can be dissipated is limited. The high-side driver is a power DMOS transistor with an internal parasitic reverse diode from the output to VS (bulk-drain-diode). The output is over current and open load protected.
42	PWMH	PWMH input: this input signal can be used to control the H-Bridge Gate drivers
43	ECDR	ECDR: using the device in EC control mode this pin is used to control the Gate of an external MOSFET.
62, 63	OUT7	High side driver output 8: see OUT9
61	OUT8	Important: This output can be configured to supply a bulb with low on-resistance or a LED with higher on-resistance in a different application.
47	OUT10/EC	High-side-driver-output 10: see OUT9 Important: Beside the OUT10-HS on/off bit this output can be switched on setting the ECON bit for electrochrome control mode with higher priority.
54	ECFD	ECFD: using the device in EC control mode this pin is used as "virtual GND" for the EC-glass. For EC-glasses, that require a negative discharge voltage, this supplies the fast discharge voltage. If no EC-glass is used, this pin must be connected to ground.
53	ECV	ECV: using the device in EC control mode this pin is used as voltage monitor input. For fast discharge an additional low-side-switch is implemented.
13	GH2	GH2: gate driver for power MOS high side switch in half-bridge 2
14	SH2	SH2: source of high-side switch in half-bridge 2
15	GL2	GL2: gate driver for power MOS low side switch in half-bridge 2
16	SL2	SL2: source of low side switch in half-bridge 2
64	GH1	GH1: gate driver for power MOS high side switch in half-bridge 1
1	SH1	SH1: source of high-side switch in half-bridge 1
4	GL1	GL1: gate driver for power MOS low side switch in half-bridge 1
5	SL1	SL1: source of low side switch in half-bridge 1
7	CP1P	CP1P: charge pump pin for capacitor 1, positive side
8	CP1M	CP1M: charge pump pin for capacitor 1, negative side
9	CP2P	CP2P: charge pump pin for capacitor 2, positive side
10	CP2M	CP2M: charge pump pin for capacitor 2, negative side
6	CP	CP: charge pump output

Figure 2. Pin connection (top view)

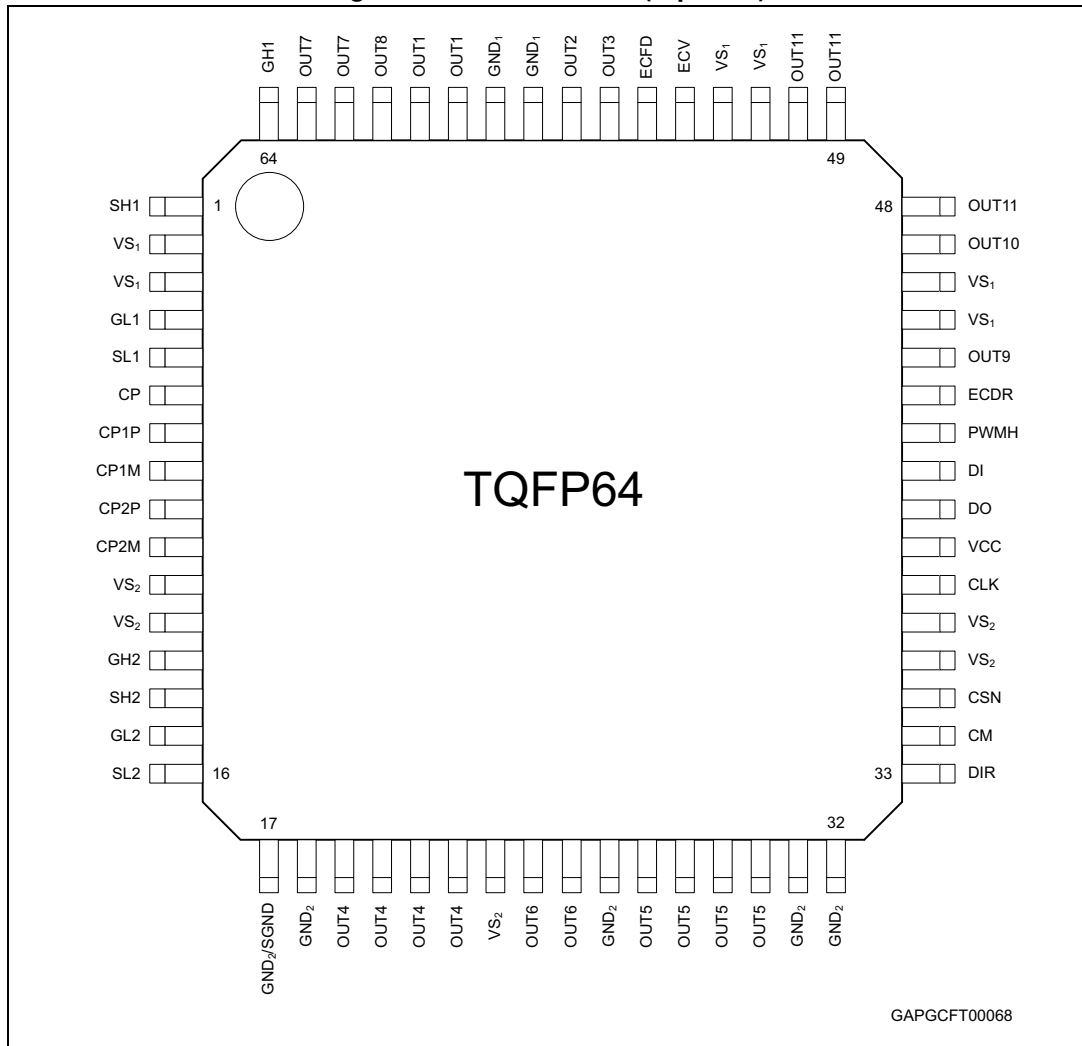

## 2 Electrical specifications

### 2.1 Absolute maximum ratings

Stressing the device above the rating listed in the “Absolute maximum ratings” table may cause permanent damage to the device. These are stress ratings only and operation of the device at these or any other conditions above those indicated in the operating sections of this specification is not implied. Exposure to Absolute Maximum Rating conditions for extended periods may affect device reliability. Refer also to the STMicroelectronics SURE Program and other relevant quality document.

**Table 3. Absolute maximum ratings**

Symbol	Parameter/test condition	Value [DC Voltage]	Unit	
$V_{S1}, V_{S2}$	DC supply voltage	-0.3 to +28	V	
	Single pulse / $t_{max} < 400$ ms “transient load dump”	-0.3 to +40	V	
$V_{CC}$	Stabilized supply voltage, logic supply	-0.3 to $V_S + 0.3$	V	
$V_{DI}, V_{CLK}, V_{CSN}, V_{DO}, V_{CM}, V_{DIR}, V_{PVMH}, V_{DIR}$	Logic input / output voltage range	-0.3 to $V_{CC} + 0.3$	V	
$V_{OUTn}, ECDR, ECV, ECFD$	Output voltage (n = 1 to 11)	-0.3 to $V_S + 0.3$	V	
$V_{SL1}, V_{SH1}, V_{SL2}, V_{SH2}$ ( $V_{Sxy}$ )	High voltage signal pins	-6 to 40	V	
$V_{GL1}, V_{GH1}, V_{GL2}, V_{GH2}$ ( $V_{Gxy}$ )	High voltage signal pins	$V_{Sxy} - 1$ to $V_{Sxy} + 10$ ; $V_{CP} + 0.3$	V	
$V_{CP1P}$	High voltage signal pins	$V_S - 0.3$ to $V_S + 10$	V	
$V_{CP2P}$	High voltage signal pins	$V_S - 0.6$ to $V_S + 10$	V	
$V_{CP1M}, V_{CP2M}$	High voltage signal pins	-0.3 to $V_S + 0.3$	V	
$V_{CP}$	High voltage signal pin	$V_{S1,2} \leq 26$ V	$V_S - 0.3$ to $V_S + 14$	V
		$V_{S1,2} > 26$ V	$V_S - 0.3$ to +40	V
$I_{OUT2,3,9,10}, ECV, ECFD$	Output current <sup>(1)</sup>	$\pm 1.25$	A	
$I_{OUT1,6,7}$	Output current <sup>(1)</sup> (low on-resistance mode)	$\pm 5$	A	
$I_{OUT7}$	Output current <sup>(1)</sup> (high on-resistance mode)	$\pm 5$	A	
$I_{OUT8}$	Output current <sup>(1)</sup>	$\pm 2.5$	A	
$I_{OUT4,5}$	Output current <sup>(1)</sup>	$\pm 10$	A	
$I_{OUT11}$	Output current <sup>(1)</sup>	$\pm 7.5$	A	
$I_{VS1cum}$	Maximum cumulated input current at $VS_1$ pins <sup>(1)</sup>	$\pm 12.5$	A	
$I_{VS2cum}$	Maximum cumulated input current at $VS_2$ pins <sup>(1)</sup>	$\pm 12.5$	A	
$I_{GND1cum}$	Maximum cumulated output current at $GND_1$ pins <sup>(1)</sup>	$\pm 5$	A	
$I_{GND2cum}$	Maximum cumulated output current at $GND_2$ pins <sup>(1)</sup>	$\pm 12.5$	A	

1. Values for the absolute maximum DC current through the bond wires. This value does not consider maximum power dissipation or other limits.

## 2.2 ESD protection

**Table 4. ESD protection**

Parameter	Value	Unit
All pins	$\pm 2^{(1)}$	kV
Power output pins: OUT1 – OUT11, ECV, ECFD	$\pm 4^{(1)}$	kV

1. HBM according to MIL 883C, Method 3015.7 or EIA/JESD22-A114-A.

## 2.3 Thermal data

**Table 5. Operating junction temperature**

Symbol	Parameter	Value	Unit
$T_j$	Operating junction temperature	-40 to 150	°C

**Table 6. Temperature warning and thermal shutdown**

Symbol	Parameter	Test condition	Min.	Typ.	Max.	Unit
$T_{jTW\ ON}$	Temperature warning threshold (junction temperature)		130		150	°C
$T_{jTS\ ON}$	Thermal shutdown threshold (junction temperature)		150		170	°C
$T_{jft}$	Thermal warning / shutdown filter time			32		μs

**Table 7. Package thermal impedance**

Symbol	Parameter	Value	Unit
$R_{thj-amb}$	Thermal resistance junction to ambient (max)	See <a href="#">Figure 5</a>	K/W

## 2.4 Package and PCB thermal data

### 2.4.1 TQFP-64 thermal data

Figure 3. TQFP-64 2 layer PCB

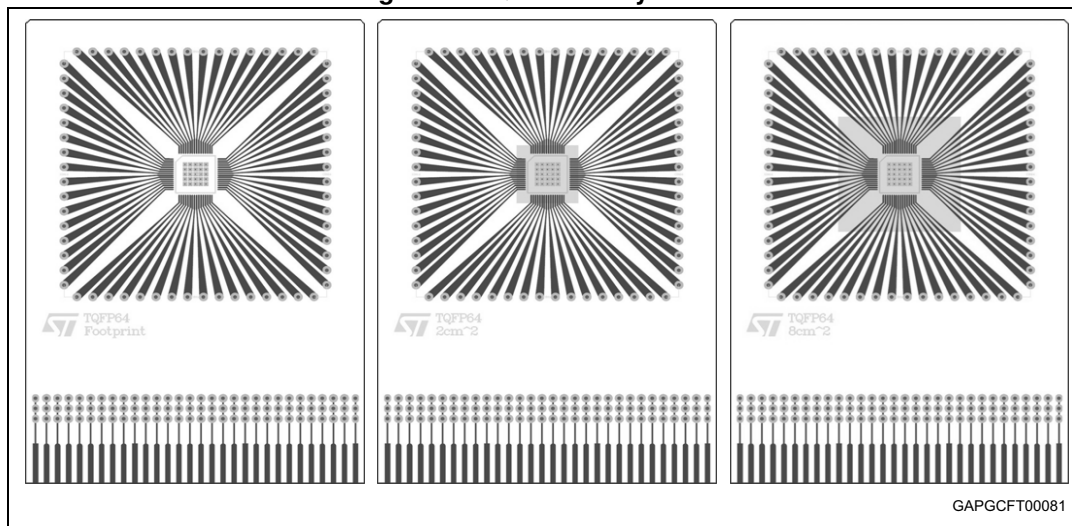
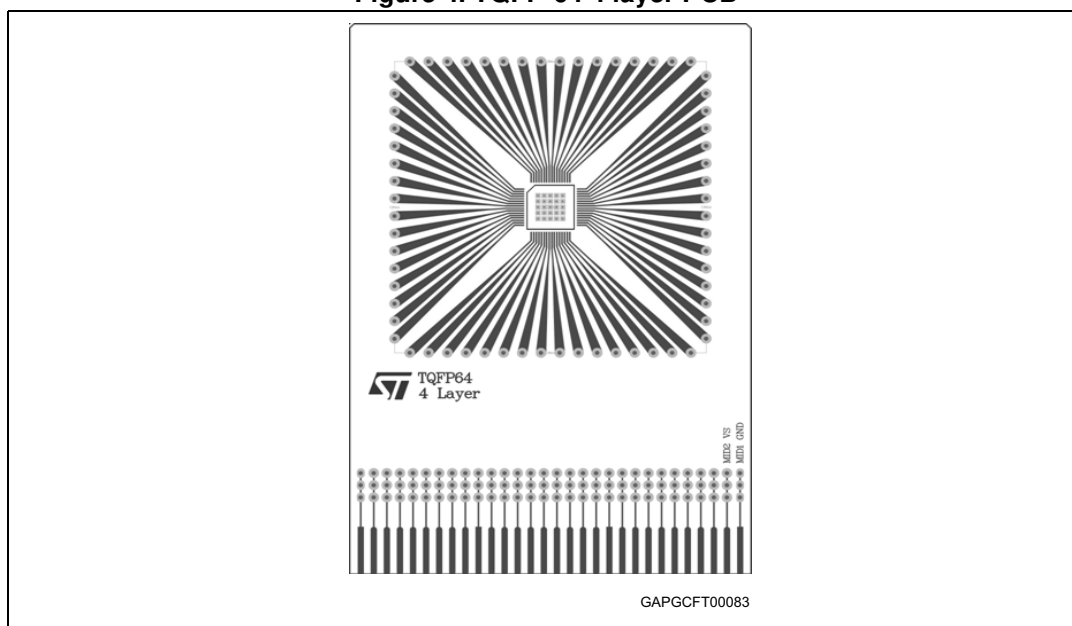
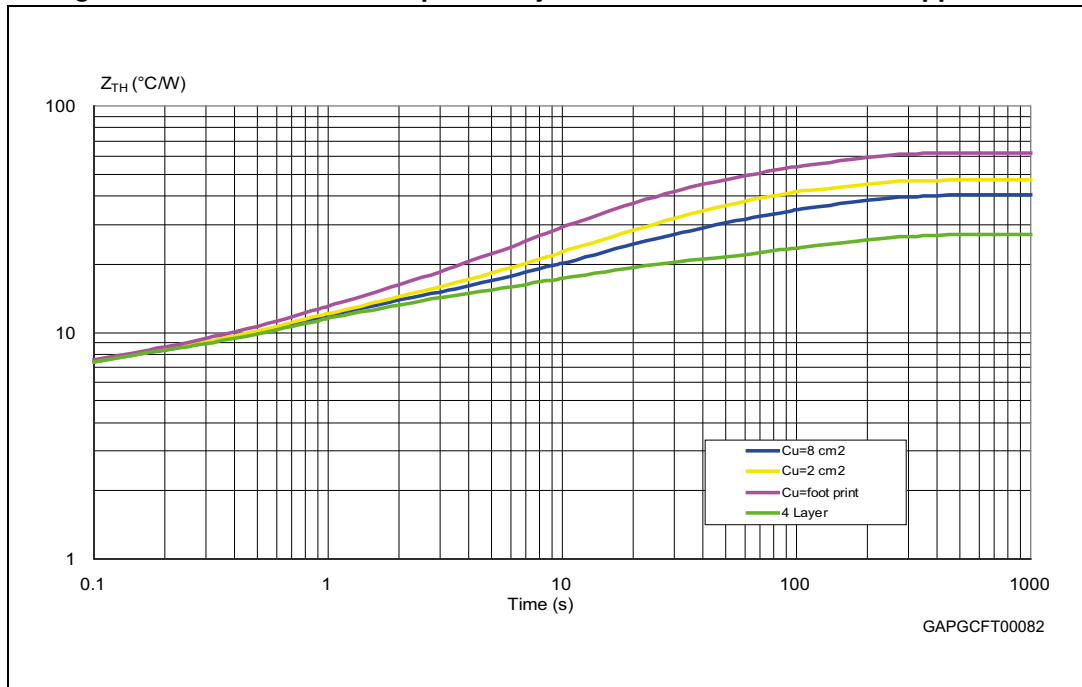

Figure 4. TQFP-64 4 layer PCB



Note: Layout condition of  $R_{th}$  and  $Z_{th}$  measurements (board finish thickness 1.6 mm +/- 10%, board double layer and four layers, board dimension 77 mm x 114 mm, board material FR4, Cu thickness 0.070mm (outer layers), Cu thickness 0.035mm (inner layers), thermal vias separation 1.2 mm, thermal via diameter 0.3 mm +/- 0.08 mm, Cu thickness on vias 0.025 mm, footprint dimension 6 mm x 6 mm). 4-layer PCB: Cu on mid1 layer, Cu on mid2 layer and Cu on bottom layer: 62 cm<sup>2</sup>.  $Z_{th}$  measured on the major power dissipator contributor

Figure 5. TQFP-64 thermal impedance junction to ambient vs PCB copper area



## 2.5 Electrical characteristics

The voltages are referred to ground and currents are assumed positive, when the current flows into the pin.  $6\text{ V} \leq V_S \leq 18\text{ V}$ ,  $4.75\text{ V} \leq V_{CC} \leq 5.5\text{ V}$ ; all outputs open;  $T_j = -40\text{ }^\circ\text{C}$  to  $150\text{ }^\circ\text{C}$ , unless otherwise specified.

**Table 8. Supply**

Symbol	Parameter	Test condition	Min.	Typ.	Max.	Unit
$V_S$	Operating voltage range		5		28	V
$I_{VS(\text{act})}$	Current consumption in active mode	$V_S = 13.5\text{ V}^{(1)}$		5	10	mA
$I_{VS(\text{stby})}$	Current consumption in standby mode	$V_S = 16\text{ V}$ ; $V_{CC} = 5.3\text{ V}$ ; standby mode OUT1 - OUT11; ECV; ECDR floating $T_{\text{TEST}} = -40\text{ }^\circ\text{C}$ to $25\text{ }^\circ\text{C}$		4	12	$\mu\text{A}$
		$T_{\text{TEST}} = 85\text{ }^\circ\text{C}^{(1)}$		6	25	$\mu\text{A}$
$V_{CC}$	Operating voltage range		4.5		5.5	V
$I_{V_{CC}(\text{active})}$	$V_{CC}$ supply current	$V_S = 16\text{ V}$ ; $V_{CC} = 5.3\text{ V}$ ; $CSN = V_{CC}$ ; active mode OUT1 - OUT11; ECV; ECDR floating		5	10	mA
$I_{V_{CC}(\text{stby})}$	$V_{CC}$ standby current	$V_S = 16\text{ V}$ ; $V_{CC} = 5.0\text{ V}$ ; $CSN = V_{CC}$ ; active mode OUT1 - OUT11; ECV; ECFD ECDR floating $T_{\text{TEST}} = -40\text{ }^\circ\text{C}$ to $25\text{ }^\circ\text{C}$		3	6	$\mu\text{A}$
		$T_{\text{TEST}} = 85\text{ }^\circ\text{C}^{(1)}$		4	8	$\mu\text{A}$
		$V_S = 16\text{ V}$ ; $V_{CC} = 5.3\text{ V}$ ; $CSN = V_{CC}$ ; active mode OUT1 - OUT11; ECV; ECFD ECDR floating $T_{\text{TEST}} = -40\text{ }^\circ\text{C}$ to $125\text{ }^\circ\text{C}$				25

1. This parameter is guaranteed by design

**Table 9. Overvoltage and undervoltage detection**

Symbol	Parameter	Test condition	Min.	Typ.	Max.	Unit
$V_{SUV\text{ ON}}$	VS UV threshold voltage <sup>(1)</sup>	$V_S$ increasing	5.6		7.2	V
$V_{SUV\text{ OFF}}$	VS UV threshold voltage <sup>(1)</sup>	$V_S$ decreasing	5		5.9	V
$V_{SUV\text{ hyst}}$	VS UV hysteresis <sup>(1)</sup>	$V_{SUV\text{ ON}} - V_{SUV\text{ OFF}}$		0.5		V
$t_{vsuv\text{ filt}}$	VS UV filter time			48		$\mu\text{s}$
$V_{SOV\text{ OFF}}$	VS OV threshold voltage <sup>(1)</sup>	$V_S$ increasing	18.5		24.5	V
$V_{SOV\text{ ON}}$	VS OV threshold voltage <sup>(1)</sup>	$V_S$ decreasing	18.0		23.5	V
$V_{SOV\text{ hyst}}$	VS OV hysteresis <sup>(1)</sup>	$V_{SOV\text{ OFF}} - V_{SOV\text{ ON}}$		1		V

**Table 9. Overvoltage and undervoltage detection (continued)**

Symbol	Parameter	Test condition	Min.	Typ.	Max.	Unit
$t_{vs\text{ovfilt}}$	VS OV filter time			48		$\mu\text{s}$
$V_{VCCRESHU}$	Upper $V_{CC}$ reset threshold <sup>(2)</sup>	$V_{CC}$ increasing	5.8		7.5	V
$V_{VCCRESHD}$	Upper $V_{CC}$ reset threshold	$V_{CC}$ decreasing	5.5		7.1	V
$V_{VCCRES\text{ hysth}}$	Upper reset hysteresis	$V_{VCCRESHU} - V_{VCCRESHD}$		0.1		V
$V_{POROFF}$	Power-on-reset threshold	$V_{CC}$ increasing	3.4		4.4	V
$V_{PORON}$	Power-on-reset threshold	$V_{CC}$ decreasing	3.1		4.1	V
$V_{POR\text{ hystL}}$	Power-on-reset hysteresis	$V_{POROFFL} - V_{PORONL}$		0.3		V

1.  $V_S = 5V$  to  $28V$

2. If  $V_{CC}$  exceeds this value all registers are reset and the device enters standby mode.

**Table 10. Current monitor output (CM)**

Symbol	Parameter	Test condition	Min.	Typ.	Max.	Unit
$V_{CM}$	Functional voltage range		0		$V_{CC} - 1V$	V
$I_{CM\text{ r}}$	Current monitor output ratio: $I_{CM}/I_{OUT1,4,5,6,11}$ and 7 (low on-resistance)	$0V \leq V_{CM} \leq V_{CC} - 1V$		1/10000		
	$I_{CM}/I_{OUT8}$ (low on-resistance)			1/6500		
	$I_{CM}/I_{OUT2,3,7,8,9,10}$ and 7,8 (high on-resistance)			1/2000		
$I_{CM\text{ acc}}$	Current monitor accuracy $accI_{CMOUT1,4,5,6,11}$ and 7 (low on-res.)	$0V \leq V_{CM} \leq V_{CC} - 1V$ ; $I_{OUTmin} = 500\text{ mA}$ ; $I_{OUT4,5max} = 5.9\text{ A}$ ; $I_{OUT11max} = 4.9\text{ A}$ ; $I_{OUT1,6max} = 2.9\text{ A}$ ; $I_{OUT7max} = 1.4\text{ A}$		4 % + 1 % FS (1)	8 % + 2 % FS (1)	
	$accI_{CMOUT2,3,8,9,10}$ and 7 (high on-res.)	$0V \leq V_{CM} \leq V_{CC} - 1V$ ; $I_{OUT.min} = 100\text{ mA}$ ; $I_{OUT2,3,9,10max} = 0.4\text{ A}$ ; $I_{OUT7max} = 0.3\text{ A}$ ; $I_{OUT8(low\ rdson)max} = 0.6\text{ A}$ ; $I_{OUT8(high\ rdson)max} = 0.3\text{ A}$				
$t_{cmb}$	Current monitor blanking time			32		$\mu\text{s}$

1. FS (full scale) =  $I_{OUTmax} * I_{CMr}$

**Table 11. Charge pump**

Symbol	Parameter	Test condition	Min.	Typ.	Max.	Unit
$V_{CP}$	Charge pump output voltage	$V_S = 6V$ ; $I_{CP} = -10\text{ mA}$	$V_S + 6$	$V_S + 7$	$V_S + 7.85$	V
		$V_S \geq 10V$ ; $I_{CP} = -15\text{ mA}$	$V_S + 11$	$V_S + 12$	$V_S + 13.5$	V



Table 11. Charge pump (continued)

Symbol	Parameter	Test condition	Min.	Typ.	Max.	Unit
$I_{CP}$	Charge pump output current <sup>(1)</sup>	$V_{CP} = V_S + 10 \text{ V};$ $V_S = 13.5 \text{ V};$ $C_1 = C_2 = C_{CP} = 100 \text{ nF}$	25		47	mA
$I_{CPlim}$	Charge pump output current limitation <sup>(2)</sup>	$V_{CP} = V_S; V_S = 13.5 \text{ V};$ $C_1 = C_2 = C_{CP} = 100 \text{ nF}$	29		70	mA
$V_{CP\_low}$	Charge pump low threshold voltage		$V_S + 4.6$	$V_S + 5$	$V_S + 5.4$	V
$T_{CP}$	Charge pump low filter time			64		$\mu\text{s}$

1.  $I_{CP}$  is the minimum current the device can provide to an external circuit without  $V_{CP}$  going below  $V_S + 10 \text{ V}$

2.  $I_{CPlim}$  is the maximum current, which flows out of the device in case of a short to  $V_S$

## 2.6 Outputs OUT1 - OUT11, ECV, ECFD

The voltages are referred to ground and currents are assumed positive, when the current flows into the pin.  $6 \text{ V} \leq V_S \leq 18 \text{ V}$ ,  $4.75 \text{ V} \leq V_{CC} \leq 5.5 \text{ V}$ ; all outputs open;  $T_j = -40 \text{ }^\circ\text{C}$  to  $150 \text{ }^\circ\text{C}$ , unless otherwise specified.

Table 12. On-resistance

Symbol	Parameter	Test condition	Min.	Typ.	Max.	Unit
$r_{ON \text{ OUT1,6}}$	On-resistance to supply or GND	$V_S = 13.5 \text{ V}; T_{amb} = +25 \text{ }^\circ\text{C};$ $I_{OUT1,6} = \pm 1.5 \text{ A}$		300	400	$\text{m}\Omega$
		$V_S = 13.5 \text{ V}; T_{amb} = +125 \text{ }^\circ\text{C};$ $I_{OUT1,6} = \pm 1.5 \text{ A}$		450	600	$\text{m}\Omega$
$r_{ON \text{ OUT2,3}}$	On-resistance to supply or GND	$V_S = 13.5 \text{ V}; T_{amb} = +25 \text{ }^\circ\text{C};$ $I_{OUT2,3} = \pm 0.4 \text{ A}$		1600	2200	$\text{m}\Omega$
		$V_S = 13.5 \text{ V}; T_{amb} = +125 \text{ }^\circ\text{C};$ $I_{OUT2,3} = \pm 0.4 \text{ A}$		2500	3400	$\text{m}\Omega$
$r_{ON \text{ OUT4,5}}$	On-resistance to supply or GND	$V_S = 13.5 \text{ V}; T_{amb} = +25 \text{ }^\circ\text{C};$ $I_{OUT4,5} = \pm 3.0 \text{ A}$		150	200	$\text{m}\Omega$
		$V_S = 13.5 \text{ V}; T_{amb} = +125 \text{ }^\circ\text{C};$ $I_{OUT4,5} = \pm 3.0 \text{ A}$		225	300	$\text{m}\Omega$
$r_{ON \text{ OUT7}}$	On-resistance to supply in low resistance mode	$V_S = 13.5 \text{ V}; T_{amb} = +25 \text{ }^\circ\text{C};$ $I_{OUT7} = -0.8 \text{ A}$		500	700	$\text{m}\Omega$
		$V_S = 13.5 \text{ V}; T_{amb} = +125 \text{ }^\circ\text{C};$ $I_{OUT7} = -0.8 \text{ A}$		700	950	$\text{m}\Omega$
	On-resistance to supply in high resistance mode	$V_S = 13.5 \text{ V}; T_{amb} = +25 \text{ }^\circ\text{C};$ $I_{OUT7} = -0.2 \text{ A}$		1600	2400	$\text{m}\Omega$
		$V_S = 13.5 \text{ V}; T_{amb} = +125 \text{ }^\circ\text{C};$ $I_{OUT7} = -0.2 \text{ A}$		2500	3400	$\text{m}\Omega$

Table 12. On-resistance (continued)

Symbol	Parameter	Test condition	Min.	Typ.	Max.	Unit
r <sub>ON OUT8</sub>	On-resistance to supply in low resistance mode	V <sub>S</sub> = 13.5 V; T <sub>amb</sub> = +25 °C; I <sub>OUT8</sub> = -0.4 A		800	1200	mΩ
		V <sub>S</sub> = 13.5 V; T <sub>amb</sub> = +125 °C; I <sub>OUT8</sub> = -0.4 A		1200	1700	mΩ
	On-resistance to supply in high resistance mode	V <sub>S</sub> = 13.5 V; T <sub>amb</sub> = +25 °C; I <sub>OUT8</sub> = -0.2 A		1600	2400	mΩ
		V <sub>S</sub> = 13.5 V; T <sub>amb</sub> = +125 °C; I <sub>OUT8</sub> = -0.2 A		2500	3400	mΩ
r <sub>ON OUT9,10</sub>	On-resistance to supply	V <sub>S</sub> = 13.5 V; T <sub>amb</sub> = +25 °C; I <sub>OUT9,10</sub> = -0.4 A		1600	2200	mΩ
		V <sub>S</sub> = 13.5 V; T <sub>amb</sub> = +125 °C; I <sub>OUT9,10</sub> = -0.4 A		2500	3400	mΩ
r <sub>ON OUT11</sub>	On-resistance to supply	V <sub>S</sub> = 13.5 V; T <sub>amb</sub> = +25 °C; I <sub>OUT11</sub> = -3.0 A		100	140	mΩ
		V <sub>S</sub> = 13.5 V; T <sub>amb</sub> = +125 °C; I <sub>OUT11</sub> = -3.0 A		140	190	mΩ
r <sub>ON ECV,ECFD</sub>	On-resistance to GND	V <sub>S</sub> = 13.5 V; T <sub>amb</sub> = +25 °C; I <sub>OUTECV,ECFD</sub> = +0.4 A		1600	2200	mΩ
		V <sub>S</sub> = 13.5 V; T <sub>amb</sub> = +125 °C; I <sub>OUTECV,ECFD</sub> = +0.4 A		2500	3400	mΩ
I <sub>QLH</sub>	Switched-off output current high side drivers of OUT1-6,9-11	V <sub>OUT</sub> = 0 V; standby mode	-5	-2		μA
		V <sub>OUT</sub> = 0 V; active mode	-10.2	-7		μA
I <sub>QLH7,8</sub>	Switched-off output current high side drivers of OUT7,8	V <sub>OUT</sub> = 0 V; standby mode	-5	-2		μA
		V <sub>OUT</sub> = 0 V; active mode	-15	-10		μA
I <sub>QLL</sub>	Switched-off output current low side drivers of OUT1-6	V <sub>OUT</sub> = V <sub>S</sub> ; standby mode		80	165	μA
		V <sub>OUT</sub> = V <sub>S</sub> - 0.5 V; active mode	-10	-7		μA
	Switched-off output current low side drivers of ECV	V <sub>OUT</sub> = V <sub>S</sub> ; standby mode	-15		15	μA
		V <sub>OUT</sub> = V <sub>S</sub> - 0.5 V; active mode	-10	-7		μA
	Switched-off output current low side drivers of ECFD	V <sub>OUT</sub> = 4 V; standby mode		80	165	μA
		V <sub>OUT</sub> = 4 V; active mode	-10		10	μA

Table 13. Power outputs switching times

Symbol	Parameter	Test condition	Min.	Typ.	Max.	Unit
$t_{d\ ON\ H}$	Output delay time high side driver on (all OUT except OUT <sub>7,8</sub> )	$V_S = 13.5\ V; V_{CC} = 5\ V;$ corresponding low side driver is not active <sup>(1)(2)(3)</sup>	10	40	80	$\mu s$
	Output delay time high side driver on (OUT <sub>7,8</sub> in high R <sub>DS(on)</sub> mode)		15	35	60	$\mu s$
	Output delay time high side driver on (OUT <sub>7,8</sub> in low R <sub>DS(on)</sub> mode)		10	35	80	$\mu s$
$t_{d\ OFF\ H}$	Output delay time high side driver off (OUT <sub>1,4,5,6,11</sub> )	$V_S = 13.5\ V;$ $V_{CC} = 5\ V^{(1)(2)(3)}$	50	150	300	$\mu s$
	Output delay time high side driver off (OUT <sub>2,3, 7,8,9,10</sub> )		40	70	100	$\mu s$
$t_{d\ ON\ L}$	Output delay time low side driver on	$V_S = 13.5\ V; V_{CC} = 5\ V;$ corresponding low side driver is not active <sup>(1)(2)(3)</sup>	15	30	70	$\mu s$
$t_{d\ OFF\ L}$	Output delay time low side driver (OUT <sub>1-6</sub> ) off	$V_S = 13.5\ V; V_{CC} = 5\ V$ <sup>(1)(2)(3)</sup>	40	150	300	$\mu s$
	Output delay time low side driver (ECV, ECFD) off	$V_S = 13.5\ V;$ $V_{CC} = 5\ V^{(1)(2)(3)}$	15	45	88	$\mu s$
$t_{d\ HL}$	Cross current protection time (OUT <sub>1-6</sub> )	$t_{cc\ ONLS\_OFFHS} - t_{d\ OFF\ H}^{(4)}$	40	200	400	$\mu s$
$t_{d\ LH}$		$t_{cc\ ONHS\_OFFLS} - t_{d\ OFF\ L}^{(4)}$				
$dV_{OUT}/dt$	Slew rate of OUT <sub>x</sub> , ECV, ECFD	$V_S = 13.5\ V;$ $V_{CC} = 5\ V^{(1)(2)(3)}$	0.08	0.2	0.6	V/ $\mu s$
$f_{PWMx(low)}$	Low PWM switching frequency	$V_S = 13.5\ V; V_{CC} = 5\ V$		122		Hz
$f_{PWMx(high)}$	High PWM switching frequency	$V_S = 13.5\ V; V_{CC} = 5\ V$		244		Hz

- $R_{load} = 16\ \Omega$  at OUT<sub>1,6</sub> and OUT<sub>7,8</sub> in low on-resistance mode
- $R_{load} = 4\ \Omega$  at OUT<sub>4,5,11</sub>
- $R_{load} = 64\ \Omega$  at OUT<sub>2,3,4,9,10</sub> ECV, ECFD and OUT<sub>7,8</sub> in high on-resistance mode
- $t_{cc}$  is the switch-on delay time if complement in half bridge has to switch off

Table 14. Current monitoring

Symbol	Parameter	Test condition	Min.	Typ.	Max.	Unit
$ I_{OC1} ,$ $ I_{OC6} $	Overcurrent threshold to supply or GND	$V_S = 13.5\ V;$ $V_{CC} = 5\ V;$ sink and source	3		5.3	A
$ I_{OC2} ,$ $ I_{OC3} ,$ $ I_{OCECFD} $			0.5		1.0	A
$ I_{OC4} ,$ $ I_{OC5} $			6		9.2	A

Table 14. Current monitoring (continued)

Symbol	Parameter	Test condition	Min.	Typ.	Max.	Unit	
I <sub>OC7</sub>	Overcurrent threshold to supply in low on-resistance mode	V <sub>S</sub> = 13.5 V; V <sub>CC</sub> = 5 V; source	1.5		2.5	A	
	Overcurrent threshold to supply in high on-resistance mode		0.35		0.65	A	
I <sub>OC8</sub>	Overcurrent threshold to supply in low on-resistance mode		0.7		1.3	A	
	Overcurrent threshold to supply in high on-resistance mode		0.35		0.65	A	
I <sub>OC9</sub>  ,  I <sub>OC10</sub>	Overcurrent threshold to supply		0.5		1.0	A	
			I <sub>OC11</sub>	5		7.5	A
I <sub>OCECV</sub>	Output current limitation to GND		V <sub>S</sub> = 13.5 V; V <sub>CC</sub> = 5 V; sink	0.5		1.0	A
t <sub>FOC</sub>	Filter time of overcurrent signal		Duration of overcurrent condition to set the status bit	10	55	100	μs
f <sub>rec0</sub>	Recovery frequency for OC; recovery frequency bit = 0			1		4	kHz
f <sub>rec1</sub>	Recovery frequency for OC; recovery frequency bit = 1			2		6	kHz
I <sub>OLD1</sub>  ,  I <sub>OLD6</sub>	Undercurrent threshold to supply or GND		V <sub>S</sub> = 13.5 V; V <sub>CC</sub> = 5 V; sink and source	8	30	80	mA
		I <sub>OLD2</sub>  ,  I <sub>OLD3</sub>  ,  I <sub>OLDECFD</sub>		10	20	30	mA
		I <sub>OLD4</sub>  ,  I <sub>OLD5</sub>		60	150	300	mA
I <sub>OLD7</sub>	Undercurrent threshold to supply in low on-resistance mode	15		40	60	mA	
	Undercurrent threshold to supply in high on-resistance mode	5		10	15	mA	
I <sub>OLD8</sub>	Undercurrent threshold to supply in low on-resistance mode	10		30	45	mA	
	Undercurrent threshold to supply in high on-resistance mode	5		10	15	mA	
I <sub>OLD9</sub>  ,  I <sub>OLD10</sub>	Undercurrent threshold to supply	10		20	30	mA	
		I <sub>OLD11</sub>		30	150	300	mA

Table 14. Current monitoring (continued)

Symbol	Parameter	Test condition	Min.	Typ.	Max.	Unit
$ I_{OLDECv} $	Undercurrent threshold to GND	$V_S = 13.5\text{ V};$ $V_{CC} = 5\text{ V};$ sink	10	20	30	mA
$t_{FOL}$	Filter time of open-load signal	Duration of open-load condition to set the status bit	0.5	2.0	3.0	ms

## 2.7 H-bridge driver

Table 15. Gate drivers for the external Power-MOS (H-bridge)

Symbol	Parameter	Test condition	Min.	Typ.	Max.	Unit
Drivers for external high-side Power-MOS						
$I_{GHx(Ch)}$	Average charge current (charge stage)	$T_j = 25\text{ °C}$		0.3		A
$R_{GHx}$	On-resistance (discharge-stage)	$V_{SHx} = 0\text{ V}; I_{GHx} = 50\text{ mA};$ $T_j = 25\text{ °C}$	4	6	8	$\Omega$
		$V_{SHx} = 0\text{ V}; I_{GHx} = 50\text{ mA};$ $T_j = 125\text{ °C}$		8	10	$\Omega$
$V_{GHxH}$	Gate-on voltage	Outputs floating	$V_{SHx} + 8$	$V_{SHx} + 10$	$V_{SHx} + 11.5$	V
$R_{GSHx}$	Passive gate-clamp resistance	$V_{GHx} = 0.5\text{ V}$		15		k $\Omega$
Drivers for external low-side Power-MOS						
$I_{GLx(Ch)}$	Average charge-current (charge stage)	$T_j = 25\text{ °C}$		0.3		A
$R_{GLx}$	On-resistance (discharge-stage)	$V_{SLx} = 0\text{ V}; I_{GHx} = 50\text{ mA};$ $T_j = 25\text{ °C}$	4	6	8	$\Omega$
		$V_{SLx} = 0\text{ V}; I_{GHx} = 50\text{ mA};$ $T_j = 125\text{ °C}$		8	10	$\Omega$
$V_{GHLx}$	Gate-on voltage	Outputs floating	$V_{SLx} + 8$	$V_{SLx} + 10$	$V_{SLx} + 11.5$	V
$R_{GSLx}$	Passive gate-clamp resistance			15		k $\Omega$

Table 16. Gate drivers for the external Power-MOS switching times

Symbol	Parameter	Test condition	Min.	Typ.	Max.	Unit
$T_{G(HL)xHL}$	Propagation delay time high to low (switch mode) <sup>(1)</sup>	$V_S = 13.5\text{ V}; V_{SHx} = 0;$ $R_G = 0\ \Omega; C_G = 2.7\text{ nF}$		1.5		$\mu\text{s}$
$T_{G(HL)xLH}$	Propagation delay time low to high (switch mode) <sup>(1)</sup>	$V_S = 13.5\text{ V}; V_{SLx} = 0;$ $R_G = 0\ \Omega; C_G = 2.7\text{ nF}$		1.5		$\mu\text{s}$

**Table 16. Gate drivers for the external Power-MOS switching times**

Symbol	Parameter	Test condition	Min.	Typ.	Max.	Unit
$I_{GHxrmax}$	Maximum charge current (current mode)	$V_S = 13.5\text{ V}; V_{SHx} = 0;$ $V_{GHx} = 1\text{ V};$ $SLEW < 4:0 \geq 1 F_H$	24.5	31	38.5	mA
$I_{GHxfmax}$	Maximum discharge current (current mode)	$V_S = 13.5\text{ V}; V_{SHx} = 0;$ $V_{GHx} = 2\text{ V};$ $SLEW < 4:0 \geq 1 F_H$	18.5	25	33	mA
$dI_{GHxr}$	Charge current accuracy	$V_S = 13.5\text{ V}; V_{SHx} = 0;$ $V_{GHx} = 1\text{ V}$	See <a href="#">Figure 6</a>			
$dI_{GHxf}$	Discharge current accuracy	$V_S = 13.5\text{ V}; V_{SHx} = 0;$ $V_{GHx} = 2\text{ V}$	See <a href="#">Figure 7</a>			
$V_{DSHxrSW}$	Switching Voltage ( $V_S - V_{SH}$ ) between current mode and switch mode (rising)	$V_S = 13.5\text{ V}$		1.5		V
$V_{TDSHxf}^{(2)}$	Trigger Voltage to sample the $V_{GSH}$ for switching between switch mode and current mode (falling)	$V_S = 13.5\text{ V}; V_{GHx} = 4\text{ V}$		1.5		V
$V_{TGSHxacc}^{(2)}$	Sampled trigger voltage accuracy	$V_S = 13.5\text{ V}; V_{SHx} = 0$		1		V
$t_{0GHxr}$	Rise time (switch mode)	$V_S = 13.5\text{ V}; V_{SHx} = 0;$ $R_G = 0\ \Omega; C_G = 2.7\text{ nF}$		45		ns
$t_{0GHxf}$	Fall time (switch mode)	$V_S = 13.5\text{ V}; V_{SHx} = 0;$ $R_G = 0\ \Omega; C_G = 2.7\text{ nF}$		85		ns
$t_{0GLxr}$	Rise time	$V_S = 13.5\text{ V}; V_{SLx} = 0;$ $R_G = 0\ \Omega; C_G = 2.7\text{ nF}$		45		ns
$t_{0GLxf}$	Fall time	$V_S = 13.5\text{ V}; V_{SLx} = 0;$ $R_G = 0\ \Omega; C_G = 2.7\text{ nF}$		85		ns
$t_{CCP}$	Programmable cross-current protection time		0.1		5	$\mu\text{s}$
$f_{PWMH}$	PWMH switching frequency <sup>(1)</sup>	$V_S = 13.5\text{ V}; V_{SLx} = 0;$ $R_G = 0\ \Omega; C_G = 2.7\text{ nF};$ PWMH - duty cycle = 50 %			50	kHz

1. Without cross-current protection time  $t_{CCP}$
2. Parameter not tested, typical value validated by characterization.

Figure 6. IGHxr ranges

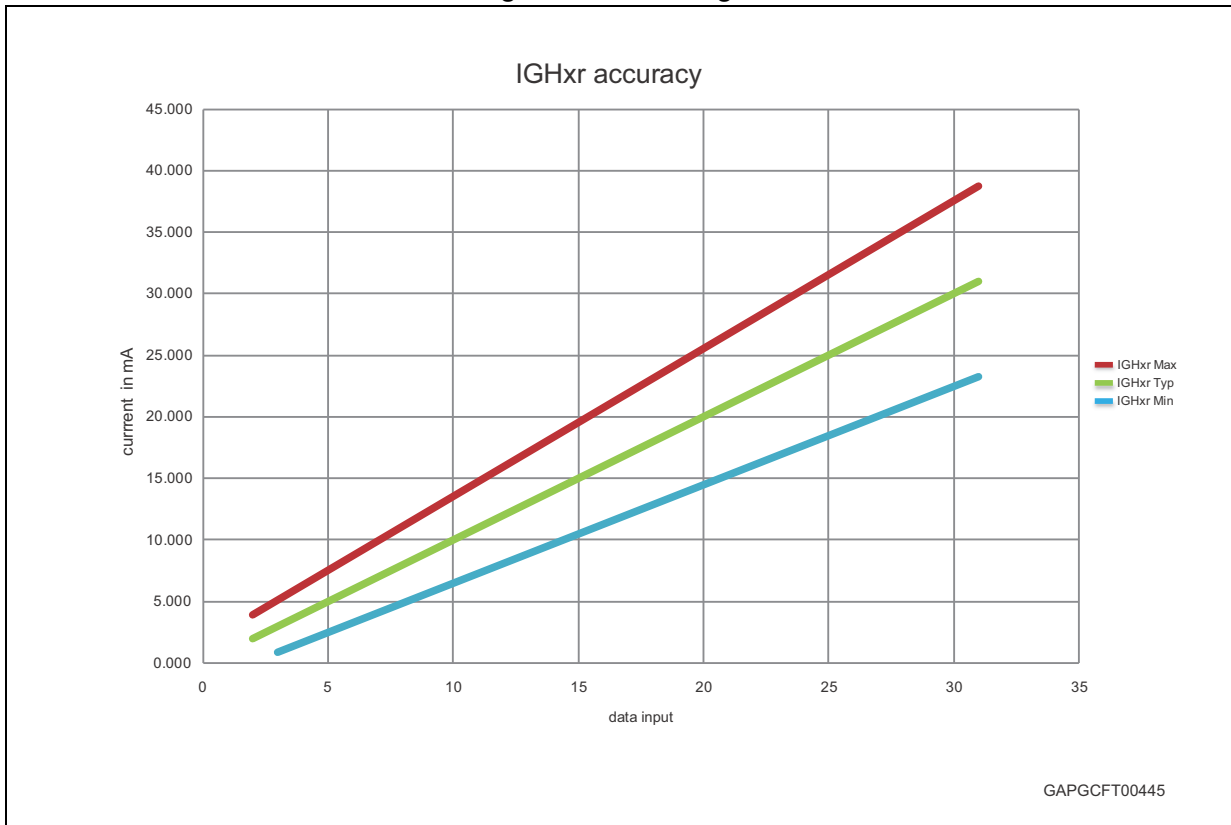

Figure 7. IGHxf ranges

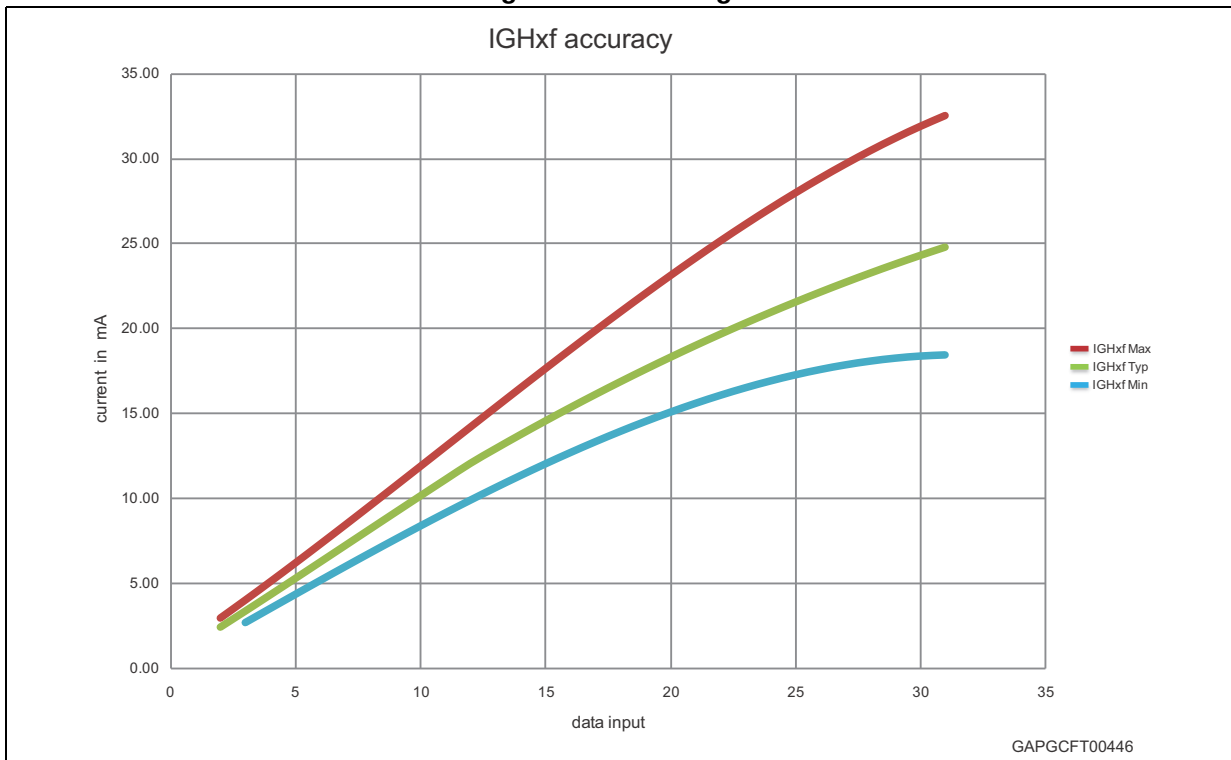
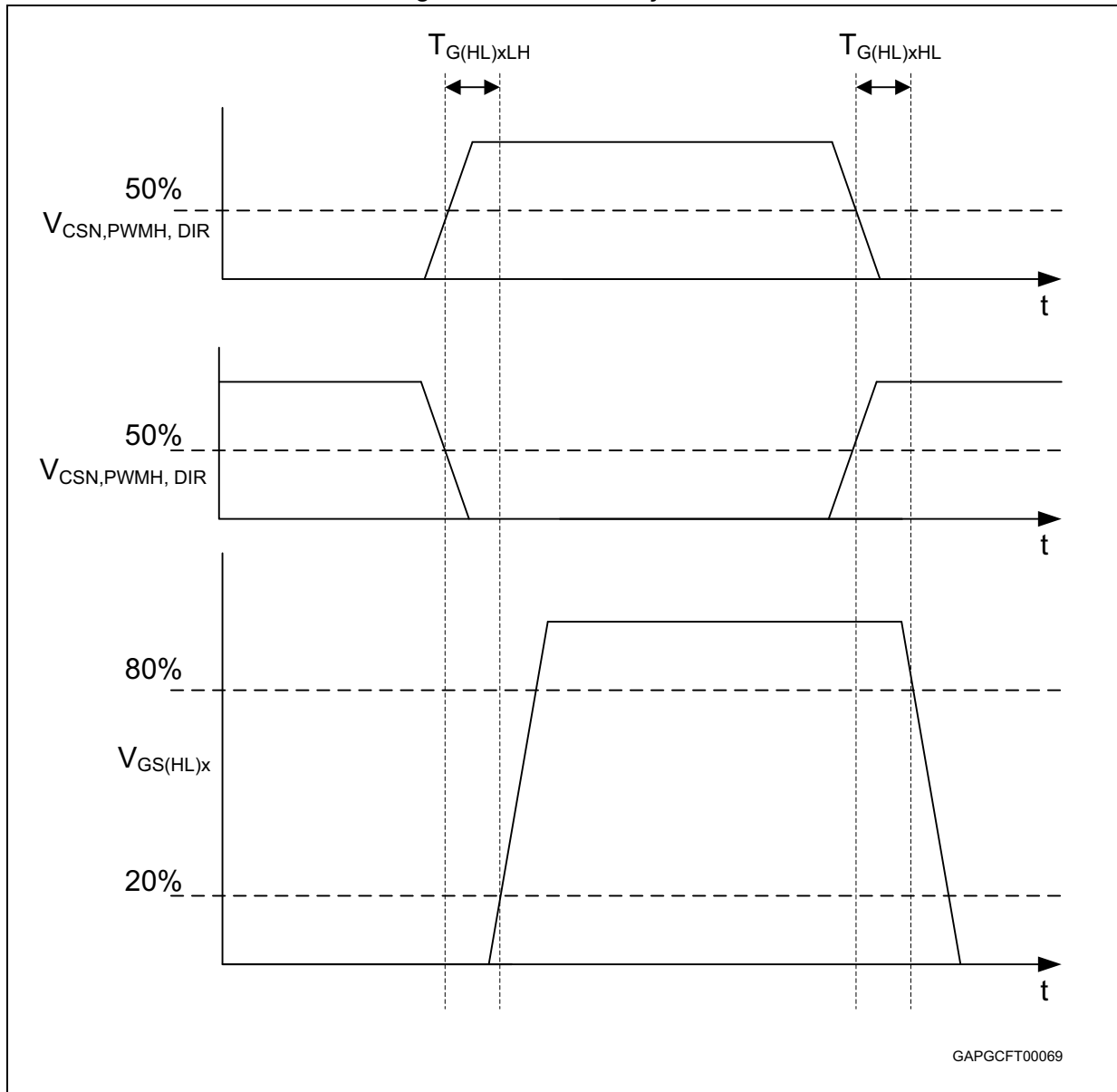

Figure 8. H-driver delay times



GAPGCFT00069

Table 17. Drain source monitoring

Symbol	Parameter	Test condition	Min.	Typ.	Max.	Unit
$V_{SCd1}$	Drain-source threshold voltage	$V_S = 13.5 \text{ V}$	0.3	0.5	0.7	V
$V_{SCd2}$	Drain-source threshold voltage	$V_S = 13.5 \text{ V}$	0.8	1	1.2	V
$V_{SCd3}$	Drain-source threshold voltage	$V_S = 13.5 \text{ V}$	1.2	1.5	1.8	V
$V_{SCd4}$	Drain-source threshold voltage	$V_S = 13.5 \text{ V}$	1.6	2	2.4	V
$t_{SCd}$	Drain-source monitor filter time		3	5.5	8	$\mu\text{s}$
$t_{scs}$	Drain-source comparator settling time	$V_S = 13.5 \text{ V}; V_{SH} = \text{jump from GND to } V_S$	—		5	$\mu\text{s}$



Table 18. Open-load monitoring

Symbol	Parameter	Test condition	Min.	Typ.	Max.	Unit
V <sub>ODSL</sub>	Low-side drain-source monitor low off-threshold voltage	V <sub>SLx</sub> = 0 V; V <sub>S</sub> = 13.5 V	0.14 * V <sub>S</sub>	0.18 * V <sub>S</sub>	0.21 * V <sub>S</sub>	V
V <sub>ODSH</sub>	Low-side drain-source monitor high off-threshold voltage	V <sub>SLx</sub> = 0 V; V <sub>S</sub> = 13.5 V	0.75 * V <sub>S</sub>	0.85 * V <sub>S</sub>	0.95 * V <sub>S</sub>	V
V <sub>OLSHx</sub>	Output voltage of selected SHx in open-load test mode	V <sub>SLx</sub> = 0 V; V <sub>S</sub> = 13.5 V		0.5 * V <sub>S</sub>		V
R <sub>pdOL</sub>	Pull-down resistance of the non-selected SHx pin in open-load mode	V <sub>SLx</sub> = 0 V; V <sub>S</sub> = 13.5 V; V <sub>SHX</sub> = 4.5 V		20		kΩ
T <sub>OL</sub>	Open-load filter time			2		ms

## 2.8 Electrochrome mirror driver

Table 19. Electrochrome mirror driver

Symbol	Parameter	Test condition	Min.	Typ.	Max.	Unit
V <sub>CTRLmax</sub>	Maximum EC-control voltage	Bit0 = 1 control reg. 2 <sup>(1)</sup>	1.4		1.6	V
		Bit0 = 0 control reg. 2 <sup>(1)</sup>	1.12		1.28	V
DNL <sub>ECV</sub> <sup>(2)</sup>	Differential non linearity		-1		1	LSB <sup>(3)</sup>
dV <sub>ECV</sub>	Voltage deviation between target and ECV	dV <sub>ECV</sub> = V <sub>target</sub> <sup>(4)</sup> - V <sub>ECV</sub> ;  I <sub>ECDR</sub>   < 1 μA	-5 % - 1LSB <sup>(3)</sup>		+5 % + 1LSB <sup>(3)</sup>	mV
dV <sub>ECVnr</sub>	Difference voltage between target and ECV sets flag if V <sub>ECV</sub> is	below it		120		mV
dV <sub>ECVhi</sub>		above it	dV <sub>ECV</sub> = V <sub>target</sub> <sup>(4)</sup> - V <sub>ECV</sub> ; toggle bitx = 1 status reg. x		-120	
t <sub>FECVNR</sub>	ECV <sub>NR</sub> filter time			32		μs
t <sub>FECVHI</sub>	ECV <sub>HI</sub> filter time			32		μs
V <sub>ECDRminHIGH</sub>	Output voltage range	I <sub>ECDR</sub> = -10 μA	4.5		5.5	V
V <sub>ECDRmaxLOW</sub>		I <sub>ECDR</sub> = 10 μA	0		0.7	V
I <sub>ECDR</sub>	Current into ECDR	V <sub>target</sub> <sup>(4)</sup> > V <sub>ECV</sub> + 500 mV; V <sub>ECDR</sub> = 3.5 V	-100		-10	μA
		V <sub>target</sub> <sup>(4)</sup> < V <sub>ECV</sub> - 500 mV; V <sub>ECDR</sub> = 1.0 V; V <sub>target</sub> = 0 V; V <sub>ECV</sub> = 0.5 V	10		100	μA
R <sub>ecdrdis</sub>	Pull-down resistance at ECDR in fast discharge mode and while EC-mode is off	V <sub>ECDR</sub> = 0.7 V; ECON = '1'; EC<5:0> = 0 or ECON = '0'			10	kΩ
DNL <sub>ECFD</sub> <sup>(2)</sup>	Differential Non Linearity		-1		1	LSB <sup>(3)</sup>
dVECFDI	Voltage deviation between target and ECFD	dVECFD = V <sub>target</sub> <sup>(4)</sup> - V <sub>ECFD</sub> ; I <sub>ECFD</sub> < TBD mA	-5 %- 1LSB <sup>(3)</sup>		+5 % + 1LSB <sup>(3)</sup>	mV

**Table 19. Electrochrome mirror driver (continued)**

Symbol	Parameter		Test condition	Min.	Typ.	Max.	Unit
$dV_{ECFDnr}^{(5)}$	Difference voltage between target and ECFD sets flag if $V_{ECFD}$ is	below it	$dV_{ECFD} = V_{target}^{(4)} - V_{ECFD}$ ; toggle status bit ECV_VNR = '1'		120		mV
$dV_{ECFDhi}$		above it	$dV_{ECFD} = V_{target}^{(4)} - V_{ECFD}$ ; Toggle status bit ECV_VH = '1'		-120		mV

1. Bit ECV\_HV = '1' or '0': ECV voltage, where  $I_{ECDR}$  can change sign
2. ECV and ECFD share same DAC circuit (see [Figure 20](#), [Figure 21](#)).
3. 1 LSB (least significant bit) =  $23.8mV_{typ}$
4.  $V_{target}$  is set by bits EC<5:0> and bit ECV\_HV; tested for each individual bit
5. Not tested since pulling pin ECFD to a low voltage against the internal source follower may lead to an overcurrent at pin ECFD HS.

## 2.9 SPI / logic – electrical characteristics

The voltages are referred to ground and currents are assumed positive, when the current flows into the pin.  $6V \leq V_S \leq 18V$ ,  $4.75V \leq V_{CC} \leq 5.5V$ ; all outputs open;  $T_j = -40^\circ\text{C}$  to  $150^\circ\text{C}$ , unless otherwise specified.

**Table 20. Delay time from Standby to Active mode**

Symbol	Parameter	Test condition	Min	Typ	Max	Unit
$t_{\text{set}}$	Delay time	Switching time from standby to active mode. Time until output drivers are enabled after CSN going to high and set bit 0 = 1 of control register 0.	250	310	410	$\mu\text{s}$
$t_{\text{wakeup}}$	Wake-up time	Switching from standby to active mode. Time after the first falling edge of CSN until the first positive CLK edge, which latches EN = 1 correctly into the device	—		20	$\mu\text{s}$
$t_{\text{awake}}$	Stay awake time	Switching from standby to active mode. After the first rising edge of CSN a second SPI frame with EN = 1 is correctly recognized	—	256		$\mu\text{s}$

**Table 21. Inputs: DI, CSN, CLK, DIR and PWMH**

Symbol	Parameter	Test condition	Min	Typ	Max	Unit
Inputs: CSN, CLK, DI, DIR, PWMH						
$V_{\text{IL}}$	Input voltage low level	$V_S = 13.5V$ ; $V_{CC} = 5.0V$	$0.3 * V_{CC}$			V
$V_{\text{IH}}$	Input voltage high level	$V_S = 13.5V$ ; $V_{CC} = 5.0V$			$0.7 * V_{CC}$	V
$V_{\text{IHYS}}$	Input hysteresis	$V_S = 13.5V$ ; $V_{CC} = 5.0V$	500			mV
$R_{\text{CSN in}}$	CSN pull-up resistor	$V_S = 13.5V$ ; $V_{CC} = 5.0V$ ; $0V \leq V_{\text{CSN}} \leq 0.7 * V_{CC}$	60	110	215	$k\Omega$
$R_{\text{CLK in}}$	CLK pull-down resistor	$V_S = 13.5V$ ; $V_{CC} = 5.0V$ ; $0.3 * V_{CC} \leq V_{\text{CLK}} \leq V_{CC}$	60	110	215	$k\Omega$
$R_{\text{DI in}}$	DI pull-down resistor	$V_S = 13.5V$ ; $V_{CC} = 5.0V$ ; $0.3 * V_{CC} \leq V_{\text{DI}} \leq V_{CC}$	60	110	215	$k\Omega$
$R_{\text{DIR}}$	DIR pull-down resistor	$V_S = 13.5V$ ; $V_{CC} = 5.0V$ ; $0.3 * V_{CC} \leq V_{\text{DIR}} \leq V_{CC}$	60	110	215	$k\Omega$
$R_{\text{PWMH}}$	PWMH pull-down resistor	$V_S = 13.5V$ ; $V_{CC} = 5.0V$ ; $0.3 * V_{CC} \leq V_{\text{PWMH}} \leq V_{CC}$	60	110	215	$k\Omega$
Output: DO						
$V_{\text{OL}}$	Output voltage low level	$I_{\text{OL}} = 5\text{ mA}$ ; $V_S = 13.5V$ ; $V_{CC} = 5.0V$			$0.3 * V_{CC}$	V
$V_{\text{OH}}$	Output voltage high level	$I_{\text{OH}} = -5\text{ mA}$ ; $V_S = 13.5V$ ; $V_{CC} = 5.0V$	$0.7 * V_{CC}$			V
$I_{\text{DOLK}}$	3-state leakage current	$V_{\text{CSN}} = V_{CC}$ ; $0 < V_{\text{DO}} < V_{CC}$	-10		10	$\mu\text{A}$

Table 22. AC-Characteristics

Symbol	Parameter	Test condition	Min.	Typ.	Max.	Unit
$C_{OUT}^{(1)}$	Output capacitance (DO)		—	—	10	pF
$C_{IN}^{(1)}$	Input capacitance (DI, CSN, CLK, DIR, PWMH)		—	—	10	pF

1. Value of input capacity is not measured in production test. Parameter guaranteed by design.

For definition of the parameters please see [Figure 9](#), [Figure 10](#) and [Figure 11](#).

Table 23. Dynamic characteristics

Symbol	Parameter	Test condition	Min.	Typ.	Max.	Unit
$t_{CSNQVL}$	DO enable from 3-state to low level	$C_{DO} = 100 \text{ pF}$ ; $I_{DO} = 1 \text{ mA}$ ; pull-up load to $V_{CC}$ ; $V_S = 13.5 \text{ V}$ ; $V_{CC} = 5 \text{ V}$		100	250	ns
$t_{CSNQVH}$	DO enable from 3-state to high level	$C_{DO} = 100 \text{ pF}$ ; $I_{DO} = -1 \text{ mA}$ ; pull-down load to GND; $V_S = 13.5 \text{ V}$ ; $V_{CC} = 5 \text{ V}$		100	250	ns
$t_{CSNQTL}$	DO disable from low level to 3-state	$C_{DO} = 100 \text{ pF}$ ; $I_{DO} = 4 \text{ mA}$ ; pull-up load to $V_{CC}$ ; $V_S = 13.5 \text{ V}$ ; $V_{CC} = 5 \text{ V}$		380	450	ns
$t_{CSNQTH}$	DO disable from high level to 3-state	$C_{DO} = 100 \text{ pF}$ ; $I_{DO} = -4 \text{ mA}$ ; pull-down load to GND; $V_S = 13.5 \text{ V}$ ; $V_{CC} = 5 \text{ V}$		380	450	ns
$t_{CLKQV}$	CLK falling until DO valid	$V_{DO} < 0.3 * V_{CC}$ or $V_{DO} > 0.7 * V_{CC}$ ; $C_{DO} = 100 \text{ pF}$ ; $V_S = 13.5 \text{ V}$ ; $V_{CC} = 5 \text{ V}$		50	250	ns
$t_{SCSN}$	CSN setup time, CSN low before rising edge of CLK	$V_S = 13.5 \text{ V}$ ; $V_{CC} = 5 \text{ V}$	400			ns
$t_{SDI}$	DI setup time, DI stable before rising edge of CLK	$V_S = 13.5 \text{ V}$ ; $V_{CC} = 5 \text{ V}$	200			ns
$T_{CLK}$	Clock Period	$V_S = 13.5 \text{ V}$ ; $V_{CC} = 5 \text{ V}$	1000			ns
$t_{HCLK}$	minimum CLK high time	$V_S = 13.5 \text{ V}$ ; $V_{CC} = 5 \text{ V}$	115			ns
$t_{LCLK}$	minimum CLK low time	$V_S = 13.5 \text{ V}$ ; $V_{CC} = 5 \text{ V}$	115			ns
$t_{HCSN}$	minimum CSN high time	$V_S = 13.5 \text{ V}$ ; $V_{CC} = 5 \text{ V}$	4			$\mu\text{s}$
$t_{SCLK}$	CLK setup time before CSN rising	$V_S = 13.5 \text{ V}$ ; $V_{CC} = 5 \text{ V}$	400			ns
$t_{rDO}$	DO rise time	$C_{DO} = 100 \text{ pF}$ ; $V_S = 13.5 \text{ V}$ ; $V_{CC} = 5 \text{ V}$		80	140	ns
$t_{fDO}$	DO fall time	$C_{DO} = 100 \text{ pF}$ ; $V_S = 13.5 \text{ V}$ ; $V_{CC} = 5 \text{ V}$		50	100	ns

Table 23. Dynamic characteristics (continued)

Symbol	Parameter	Test condition	Min.	Typ.	Max.	Unit
$t_{r\text{ in}}$	rise time of input signal DI, CLK, CSN	$V_S = 13.5\text{ V}; V_{CC} = 5\text{ V}$			100	ns
$t_{f\text{ in}}$	fall time of input signal DI, CLK, CSN	$V_S = 13.5\text{ V}; V_{CC} = 5\text{ V}$			100	ns

Figure 9. SPI timing parameters

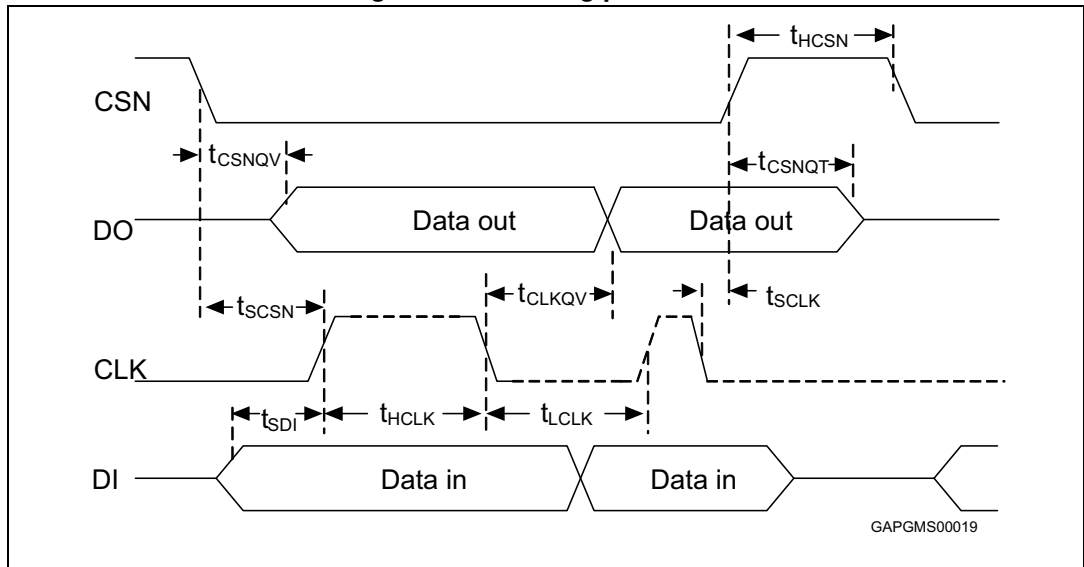

Figure 10. SPI input and output timing parameters

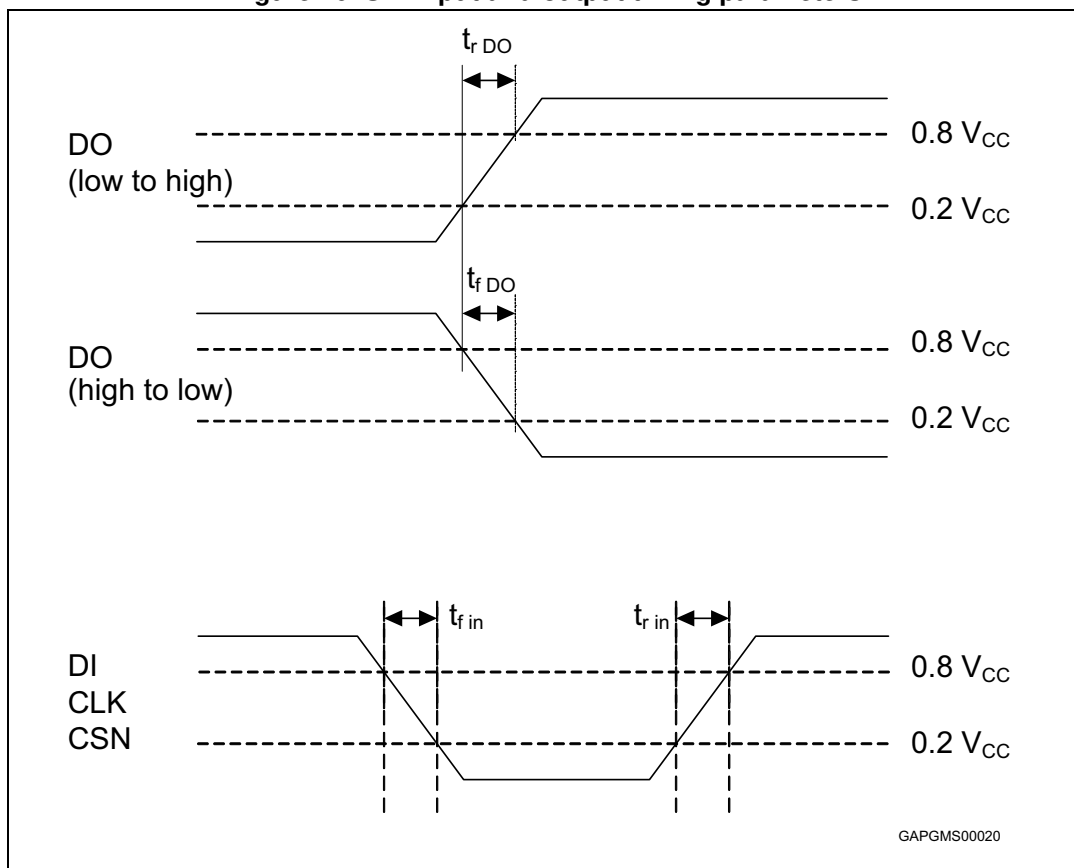

Figure 11. SPI delay description

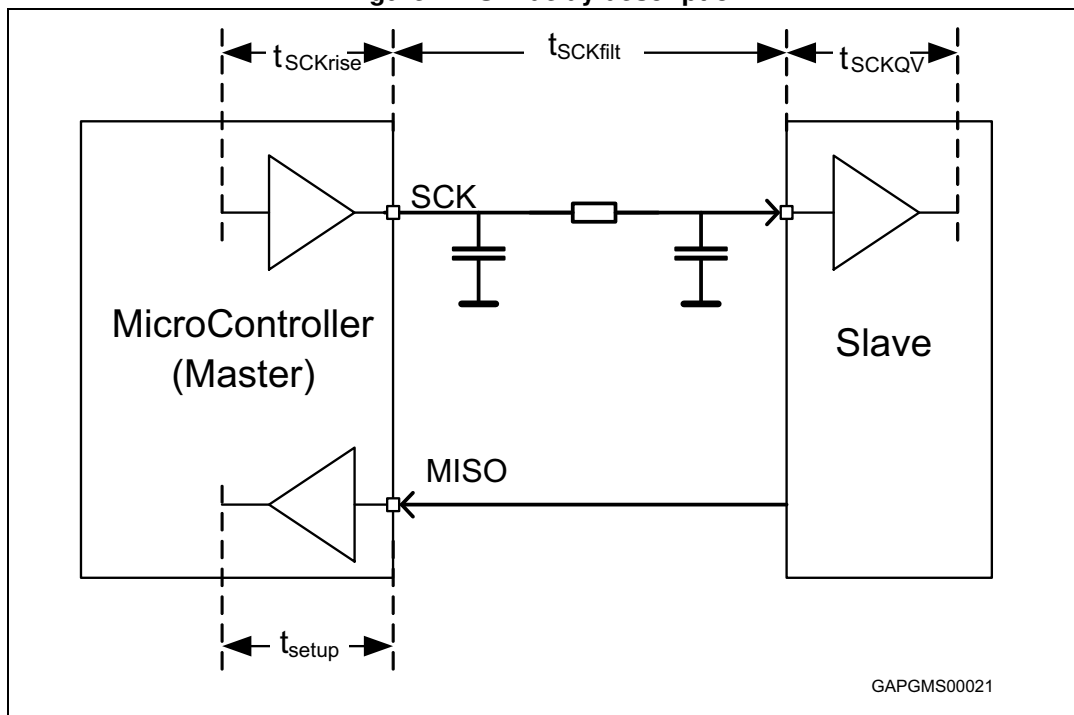
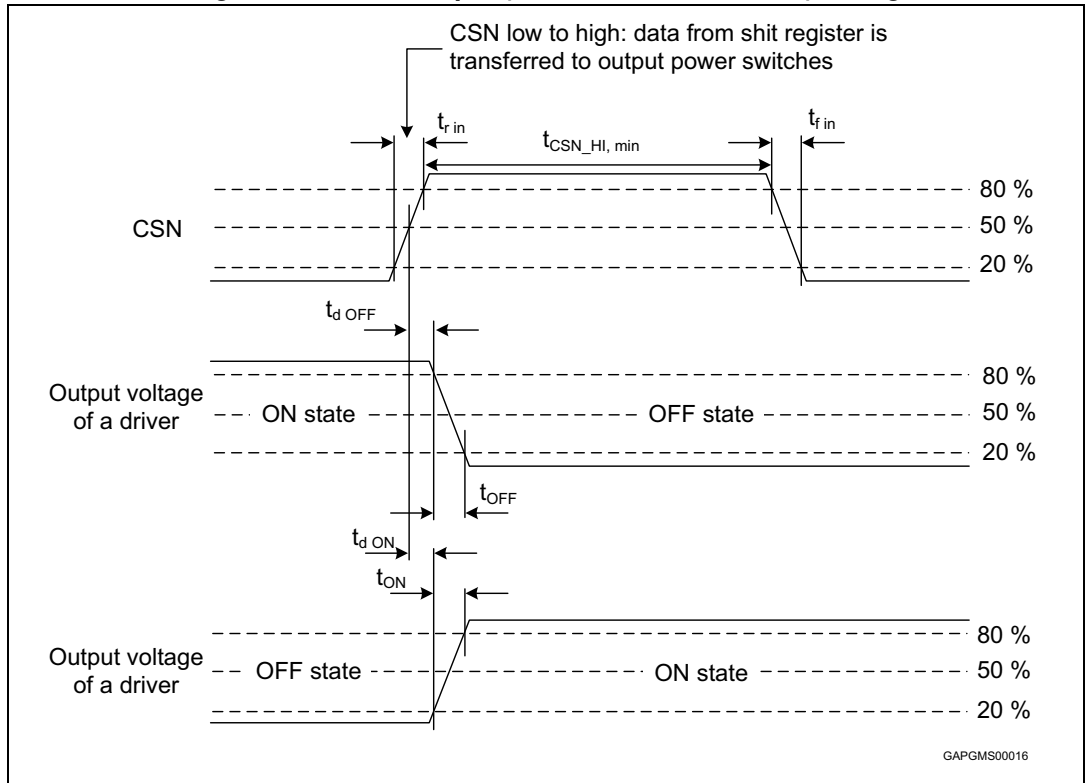

Table 24. Watchdog

Symbol	Parameter	Test condition	Min.	Typ.	Max.	Unit
TC <sub>WDTO</sub>	Watchdog time out		50	64	100	ms

Figure 12. Power-output (OUT<11:1>, ECV, ECFD) timing



## 3 Application information

### 3.1 Dual power supply: $V_S$ and $V_{CC}$

The power supply voltage  $V_S$  supplies the power drivers and the Power-MOS gate drivers. For supplying the high-side drivers for the power- and gate-driver outputs, an internal charge-pump is used. The SPI interface and the logic circuitry is supplied by  $V_{CC}$ .

Due to the independent  $V_{CC}$  supply the control and status information are not lost, if there are spikes or glitches on the power supply voltage.

### 3.2 Wake up and Active mode/standby mode

After power up of  $V_S$  and  $V_{CC}$  the device operates in standby-mode. Pulling the signal CSN to low level wakes the device up and the analog part is activated (active mode). After at least 10  $\mu\text{s}$ , the first SPI communication is valid and the EN-bit can be used to set the EN-mode.

The device can be set into active mode writing a '1' into the EN-register. If the EN-register is not set to '1', the device goes back to standby mode typical 256  $\mu\text{s}$  after the rising edge of CSN and all latched data are cleared. In standby mode the current at  $V_S$  ( $V_{CC}$ ) is less than 6  $\mu\text{A}$  (5  $\mu\text{A}$ ) for CSN = high (DO in 3-state). It is recommended to switch all outputs off before entering standby mode.

### 3.3 Charge pump

The charge pump uses two external capacitors, which are switched with a frequency of typically 125 kHz. The output of the charge pump has a current limitation. In standby mode and after a thermal shutdown has been triggered the charge pump is disabled. If the charge pump output voltage remains too low for longer than  $T_{CP}$ , the power-MOS outputs, the EC-control are switched off and the H-Bridge gate drivers are switched to resistive low. The CP\_LOW bit has to be cleared through a software reset to reactivate the drivers.

### 3.4 Diagnostic functions

All diagnostic functions (overcurrent, open-load, power supply overvoltage /undervoltage, temperature warning and thermal shutdown) are internally filtered. The condition has to be valid for at least the associated filter time before the corresponding status bit in the status registers is set. The filters are used to improve the noise immunity of the device. The open-load and temperature warning functions are intended for information purpose and do not change the state of the output drivers. On contrary, the overcurrent condition disables the corresponding driver and thermal shutdown disables all drivers. Without setting the overcurrent recovery bits in the input data register, the microcontroller has to clear the overcurrent status bits to reactivate the corresponding drivers.



### 3.5 Overvoltage and undervoltage detection at $V_S$

If the power supply voltage  $V_S$  rises above the overvoltage threshold  $V_{SOV\_OFF}$ , the outputs OUT1 to OUT11, ECDR, ECV, ECFD are switched to high impedance state, the charge pump is disabled and the H-Bridge gate drivers are switched into sink condition to protect the H-bridge and the load. When the voltage  $V_S$  drops below the undervoltage threshold  $V_{SUV\_OFF}$  (UV-switch-OFF voltage), the output stages are switched to high impedance to avoid the operation of the power devices without sufficient gate driving voltage (increased power dissipation). If the supply voltage  $V_S$  recovers to normal operating voltage, the charge pump is switched on again, the CP\_LOW bit is cleared and the output stages return to the programmed state. If the undervoltage/overvoltage recovery disable bit is set, the automatic turn-on of the drivers is deactivated.

If the undervoltage/overvoltage recovery disable bit (OV\_UV\_RD) is set, the microcontroller needs to clear the status bits to reactivate the drivers. It is recommended to set OV\_UV\_RD bit to avoid a possible high current oscillation in case of a shorted output to GND and low battery voltage.

### 3.6 Overvoltage and undervoltage detection at $V_{CC}$

At power-on ( $V_{CC}$  increases from undervoltage to  $V_{POROFF}$ ) the circuit is initialized by an internally generated power-on-reset (POR). If the voltage  $V_{CC}$  decreases below the low threshold ( $V_{PORON}$ ), the outputs are switched to 3-state (high impedance) and the status registers are cleared. If the voltage at pin  $V_{CC}$  increases above the  $V_{CC}$  reset high threshold  $V_{VCCRESHU}$ , the device enters the reset state, all outputs are switched off and all internal registers are cleared. After the voltage at pin  $V_{CC}$  has decreased below  $V_{VCCRESHL}$ , the device enters normal operating mode again and the internal registers are reset.

### 3.7 Temperature warning and shutdown

If the junction temperature rises above the temperature warning threshold ( $T_{jTW}$ ), a temperature warning flag is set after the temperature warning filter time ( $T_{jft}$ ) and can be read via SPI. If the junction temperature increases above the temperature shutdown threshold ( $T_{jTS}$ ), the thermal shutdown bit is set and the power transistors of all output stages are switched off to protect the device after the thermal shutdown filter time. The gates of the H-Bridge are discharged by the 'Resistive Low' mode.

The temperature warning and thermal shutdown flags are latched and must be cleared by the microcontroller. This is done by a read and clear command on an arbitrary register, because both bits are part of the global status register.

After these bits have been cleared, the output stages are reactivated. If the temperature is still above the thermal warning threshold, the thermal warning bit is set after  $T_{jft}$ . Once this bit is set and the temperature is above the temperature shutdown threshold, temperature shutdown is detected after  $T_{jft}$  and the outputs are switched off. Therefore the minimum time after which the outputs are switched off after the bits have been cleared in case the temperature is still above the thermo-shutdown threshold is twice the thermo-warning/-shutdown filter time  $T_{jft}$ .

### 3.8 Inductive loads

Each half bridge is built by internally connected high- and low-side power DMOS transistors. Due to the built-in reverse diodes of the output transistors, inductive loads can be driven at the outputs OUT1 to OUT6 without external freewheeling diodes. The high-side drivers OUT7 to OUT11 are intended to drive resistive loads. Therefore only a limited energy ( $E < 1 \text{ mJ}$ ) can be dissipated by the internal ESD-diodes in freewheeling condition. For inductive loads ( $L > 100 \mu\text{H}$ ) an external freewheeling diode connected between GND and the corresponding output is required. The low side driver at ECV does not have a freewheel diode built into the device.

### 3.9 Open-load detection

The open load detection monitors the load current in each activated output stage. If the load current is below the open load detection threshold for at least  $t_{\text{FOL}}$  the corresponding open-load bit is set in the status register. Due to mechanical/electrical inertia of typical loads a short activation of the outputs (e.g. 3 ms) can be used to test the open load status without changing the mechanical/electrical state of the loads.

### 3.10 Overcurrent detection

In case of an overcurrent condition, a flag is set in the status register. If the overcurrent signal is valid for at least  $T_{\text{FOC}}$ , the overcurrent flag is set and the corresponding driver is switched off to reduce the power dissipation and to protect the integrated circuit. If the overcurrent recovery bit of the output is cleared, the microcontroller has to clear the status bits to reactivate the corresponding driver.

### 3.11 Current monitor

The current monitor output sources a current image at the current monitor output, which has three fixed ratios of the instantaneous current of the selected high-side driver. Outputs with a resistance of  $500 \text{ m}\Omega$  and higher have a ratio of  $1/2000$ , except for OUT8, which has a ratio of  $1/6500$ , and those with a lower resistance one of  $1/10000$ . The signal at output CM is blanked after switching on the driver until correct settlement of the circuitry. The bits  $\text{CM\_SEL}_{<3:0>}$  define which of the outputs are multiplexed to the current monitor output CM. The current monitor output allows a more precise analysis of the actual state of the load rather than the detection of an open- or overload condition. For example, it can be used to detect the motor state (starting, free running, stalled). Moreover, it is possible to control the power of the defroster more precisely by measuring the load current. The current monitor output is enabled after the current-monitor blanking time, when the selected output is switched on. If this output is off, the current monitor output is in high-impedance mode.

### 3.12 PWM mode of the power outputs

Each driver has a corresponding PWM enable bit, which can be programmed by the SPI interface. If the PWM enable bit is set, the output is controlled by the logically AND-combination of an internally generated PWM signal and the output control bit of the corresponding driver. The PWM-Frequency of all outputs can be programmed to either 122 Hz or 244 Hz typically. The on-duty-cycle is set by the four 7-bit registers, which control

one PWM counter each. Therefore the maximum on-time is 100% - 1 LSB.  
1 LSB = 100/128 %. Which output uses which corresponding PWM driver can be seen in the SPI register definition. When programming a specific duty-cycle, the output on/off times as well as the slopes must be taken into account.

### 3.13 Cross-current protection

The six half-bridges of the device are crosscurrent protected by an internal delay time. If one driver (LS or HS) is turned off, the activation of the other driver of the same half bridge is automatically delayed by the crosscurrent protection time. After the crosscurrent protection time is expired the slew-rate limited switch-off phase of the driver is changed to a fast turn-off phase and the opposite driver is turned-on with slew-rate limitation. Due to this behavior, it is always guaranteed that the previously activated driver is completely turned off before the opposite driver starts to conduct

### 3.14 Programmable soft-start function to drive loads with higher inrush current

Loads with start-up currents higher than the overcurrent limits (e.g. inrush current of lamps, Start current of motors and cold resistance of heaters) can be driven by using the programmable softstart function (i.e. overcurrent recovery mode). Each driver has a corresponding overcurrent recovery bit. If this bit is set, the device automatically switches the outputs on again after a programmable recovery time. The duty cycle in overcurrent condition can be programmed by the SPI interface to about 12 % or 25 %. The PWM modulated current provides sufficient average current to power up the load (e.g. heat up the bulb) until the load reaches operating condition. The PWM frequency settles at 1.7 kHz and 3 kHz. The device itself cannot distinguish between a real overload and a non linear load like a light bulb. A real overload condition can only be qualified by time. For overload detection the microcontroller can switch on the light bulbs by setting the overcurrent recovery bit for the first e.g. 50 ms. After clearing the recovery bit the output is automatically switched off, if the overload condition remains. This overcurrent detection procedure has to be followed in order to make it possible to switch on the low side driver of a bridge output, if the associated high-side driver has been used in recovery mode before.

Figure 13. Overcurrent recovery mode

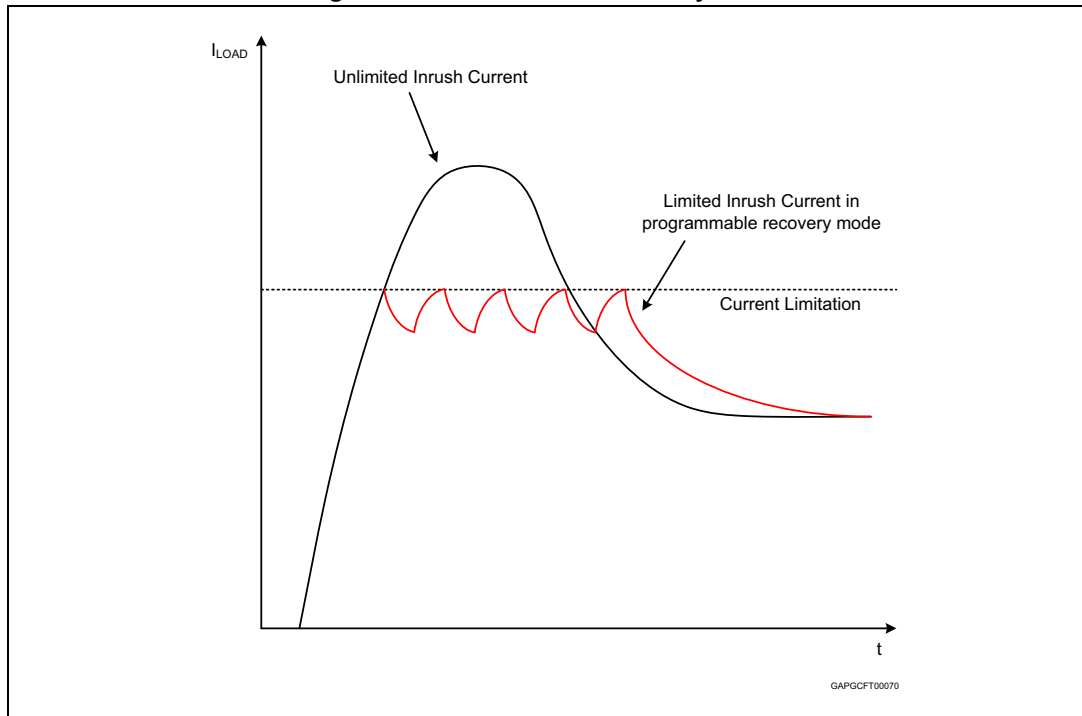

### 3.15 H-bridge control (DIR, PWMH, bits SD, SDS)

The PWMH input controls the drivers of the external H-bridge transistors. The motor direction can be chosen with the direction input (DIR), the duty cycle and frequency with the PWMH input. With the SPI-registers SD and SDS four different slow-decay modes (via drivers and via diode) can be selected using the high side or the low side transistors. Unconnected inputs are defined by internal pull-down current.

Table 25. H-bridge control truth table

N°	Control pins		Control bits			Failure bits					Output pin				Comment
	DIR	PWMH	HEN	SD	SDS	CP_LOW	OV	UV	DS	TSD	GH1	GL1	GH2	GL2	
1	X	X	0	X	X	X	X	X	X	X	RL	RL	RL	RL	H-bridge disabled
2	X	X	1	X	X	1	0	0	0	0	RL	RL	RL	RL	Charge pump voltage too low
3	X	X	1	X	X	0	X	X	X	1	RL	RL	RL	RL	Thermo-shutdown
4	X	X	1	X	X	0	1	0	0	0	L	L	L	L	Overvoltage
5	X	X	1	X	X	0	0	0	1	0	L <sup>(1)</sup>	L <sup>(1)</sup>	L <sup>(1)</sup>	L <sup>(1)</sup>	Short-circuit <sup>(1)</sup>
6	0	1	1	X	X	0	0	0	0	0	L	H	H	L	Bridge H2/L1 on
7	X	0	1	0	0	0	0	0	0	0	L	H	L	H	Slow-decay mode LS1 and LS2 on
8	0	0	1	0	1	0	0	0	0	0	L	H	L	L	Slow-decay mode LS1 on
9	1	0	1	0	1	0	0	0	0	0	L	L	L	H	Slow-decay mode LS2 on

Table 25. H-bridge control truth table (continued)

N°	Control pins		Control bits			Failure bits					Output pin				Comment
	DIR	PWMH	HEN	SD	SDS	CP_LOW	OV	UV	DS	TSD	GH1	GL1	GH2	GL2	
10	1	1	1	X	X	0	0	0	0	0	H	L	L	H	Bridge H1/L2 on
11	X	0	1	1	0	0	0	0	0	0	H	L	H	L	Slow-decay mode HS1 and HS2 on
12	0	0	1	1	1	0	0	0	0	0	L	L	H	L	Slow-decay mode HS2 on
13	1	0	1	1	1	0	0	0	0	0	H	L	L	L	Slow-decay mode HS1 on

1. Only the half-bridge (low and high-side), in which one MOSFET is in short circuit condition is switched off. Both MOSFETs of the other half-bridge remain active and driven by DIR and PWMH

### 3.16 H-bridge driver slew-rate control

The rising and falling slope of the drivers for the external high-side Power-MOS can be slew rate controlled. If this mode is enabled the gate of the external high-side Power-MOS is driven by a current source instead of a low-impedance output driver switch as long as the drain-source voltage over this Power-MOS is below the switch threshold. The current is programmed using the bits SLEW<4:0>, which represent a binary number. This number is multiplied by the minimum current step. This minimum current step is the maximum source-/sink-current ( $I_{GHx_{rmax}} / I_{GHx_{fmax}}$ ) divided by 31. Programming SLEW<4:0> to 0 disables the slew rate control and the output is driven by the low-impedance output driver switch.

Figure 14. H-bridge GSHx slope

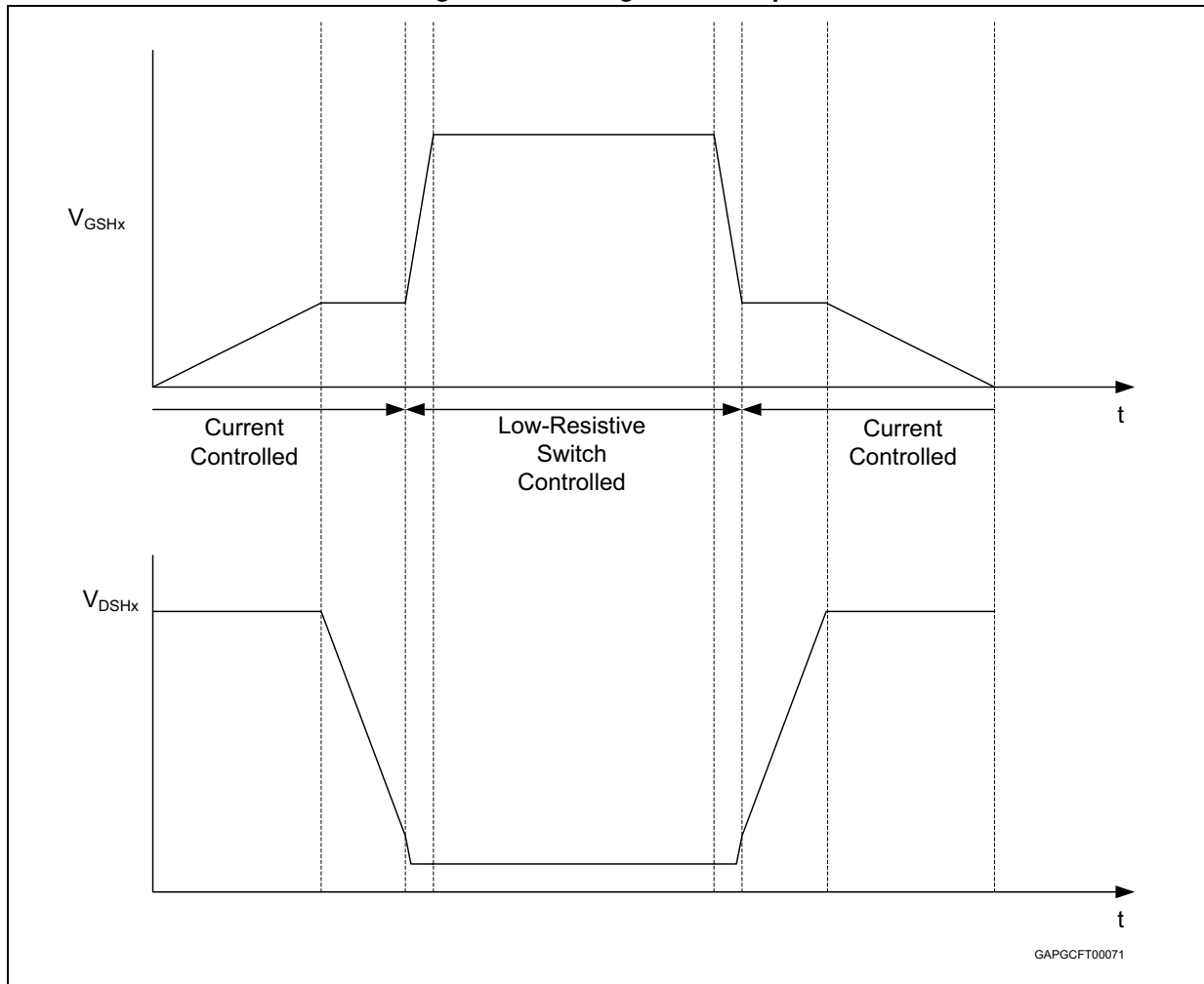

### 3.17 Resistive low

The resistive output mode protects the L99DZ80EP and the H-bridge in the standby mode and in some failure modes (thermal shut down (TSD), charge pump low (CP\_LOW) and stuck-at-'1' at pin DI). When a gate driver changes into the resistive output mode due to a failure a sequence is started. In this sequence the concerning driver is switched into sink condition for 32  $\mu$ s to 64  $\mu$ s to ensure a fast switch-off of the H-bridge transistor. If slew rate control is enabled, the sink condition is slew-rate controlled. Afterwards the driver is switched into the resistive output mode (resistive path to source).

### 3.18 Short circuit detection/drain source monitoring

The drain source voltage of each activated external MOSFET of the H-bridge is monitored by comparators to detect shorts to ground or battery. If the voltage-drop over the external MOSFET exceeds the threshold voltage  $V_{SCd}$  for longer than the short current detection time  $t_{SCd}$  the corresponding gate driver switches the external MOSFET off and the corresponding drain source monitoring flag (DS\_MON[3:0]) is set. The DS\_MON bits have

to be cleared through the SPI to reactivate the gate drivers. The drain source monitoring has a filter time of typ. 6  $\mu$ s. This monitoring is only active while the corresponding gate driver is activated. If a drain-source monitor event is detected, the corresponding gate-driver remains activated for at maximum the filter time. When the gate driver switches on, the drain-source comparator requires the specified settling time until the drain-source monitoring is valid. During this time, this drain-source monitor event may start the filter time. The threshold voltage  $V_{SCd}$  can be programmed using the SPI.

**Table 26. H-bridge DS-monitor threshold**

DIAG<1>	DIAG<0>	Monitoring threshold voltage (typical)
0	0	$V_{SCD1} = 0.5 \text{ V}$
0	1	$V_{SCD2} = 1.0 \text{ V}$
1	0	$V_{SCD3} = 1.5 \text{ V}$
1	1	$V_{SCD4} = 2.0 \text{ V}$

**Figure 15. H-bridge diagnosis**

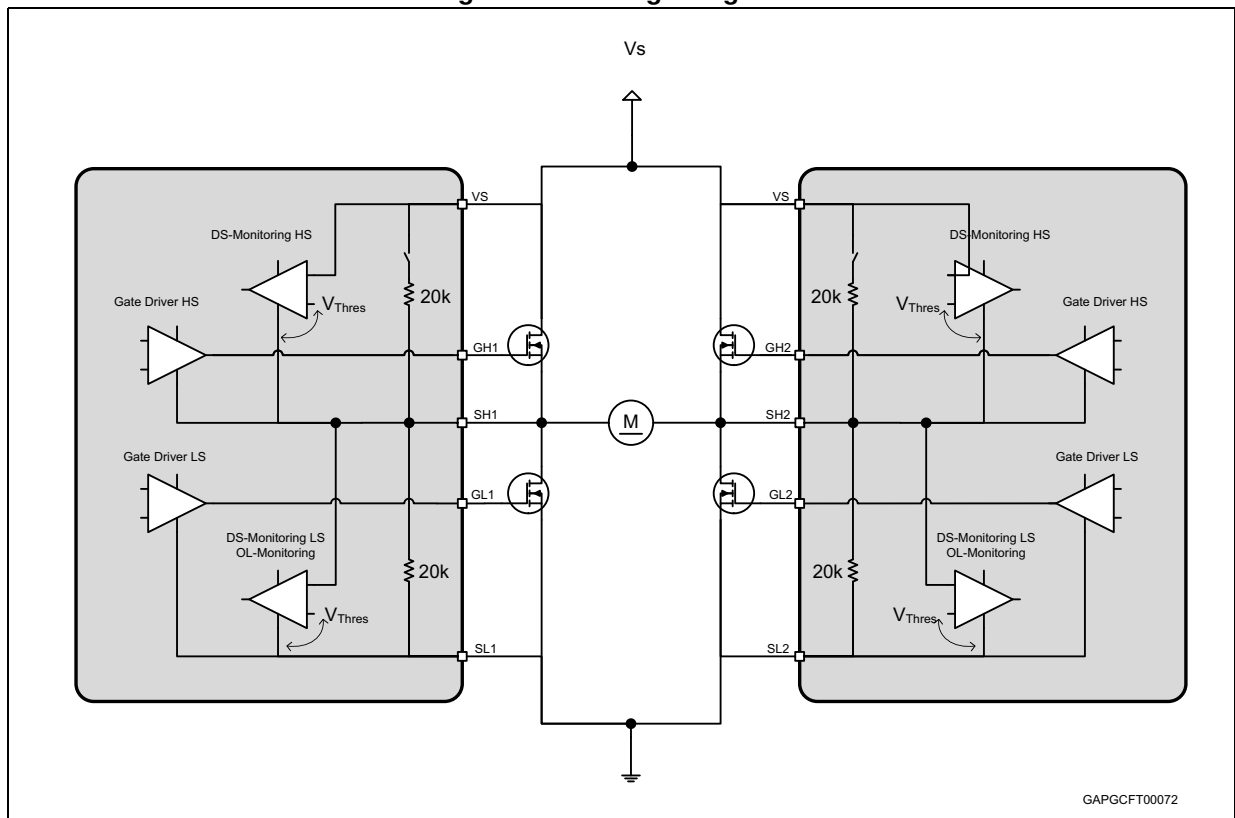

### 3.19 H-bridge monitoring in off-mode

The drain source voltages of the H-Bridge driver external transistors can be monitored, while the transistors are switched off. If either bit OL\_H1L2 or OL\_H2L1 is set to '1', while bit HEN = '1', the H-drivers enter resistive low mode and the drain-source voltages can be monitored. Since the pull-up resistance is equal to the pull-down resistance on both sides of

the bridge a voltage of  $2/3 V_S$  on the pull-up high-side and  $1/3 V_S$  on the low side is expected, if they drive a low-resistive inductive load (e.g. motor). If the drain source voltage on each of these Power-MOS is less than  $1/6 V_S$ , the drain-source monitor bit of the associated driver is set.

In case of a short to ground the drain-source monitor bits of both low-side gate drivers are set. A short to  $V_S$  can be diagnosed by setting the “H-Bridge OL high threshold (H-OLTH HIGH)” bit to one.

Figure 16. H-bridge open-load detection (no open-load detected)

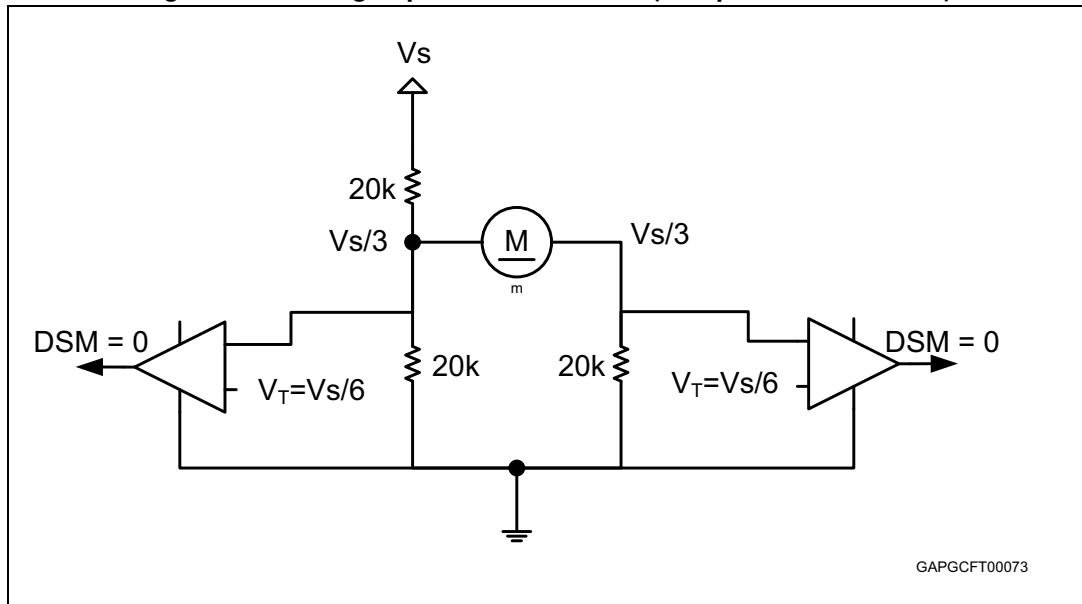

GAPGCFT00073

Figure 17. H-bridge open-load detection (open-load detected)

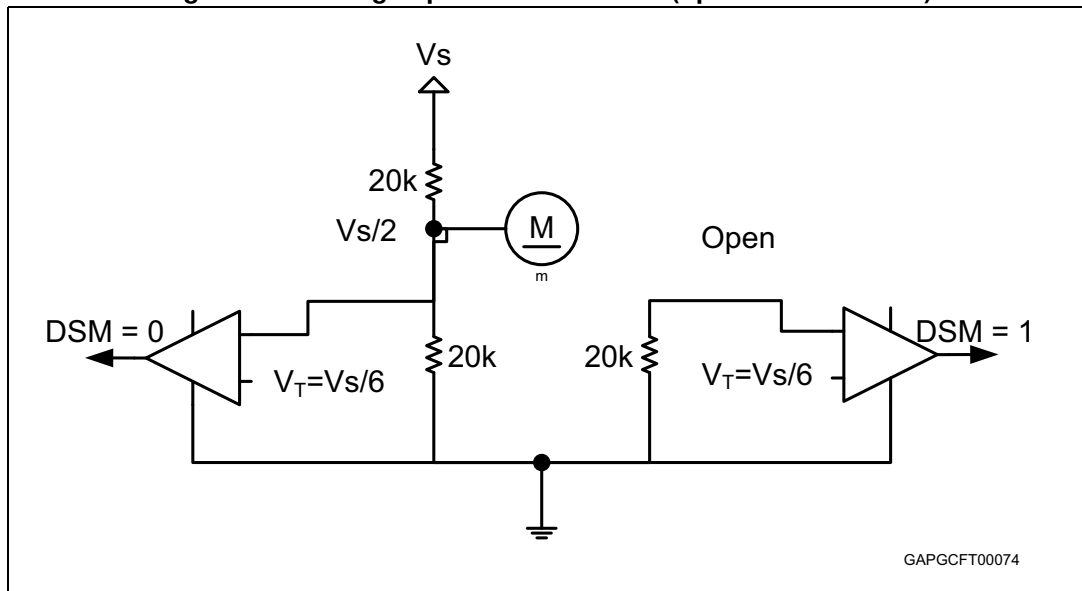

GAPGCFT00074

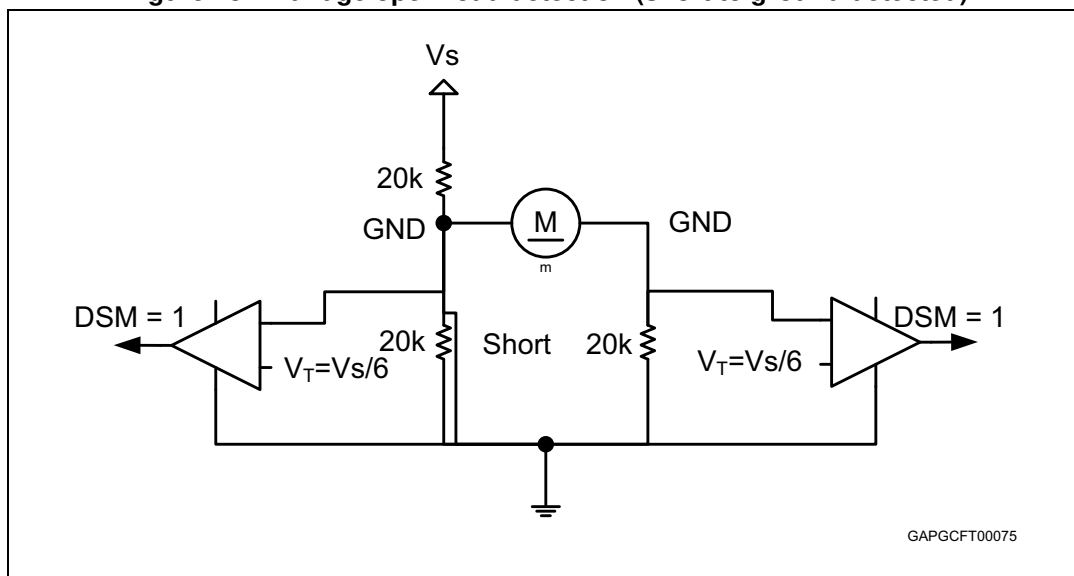
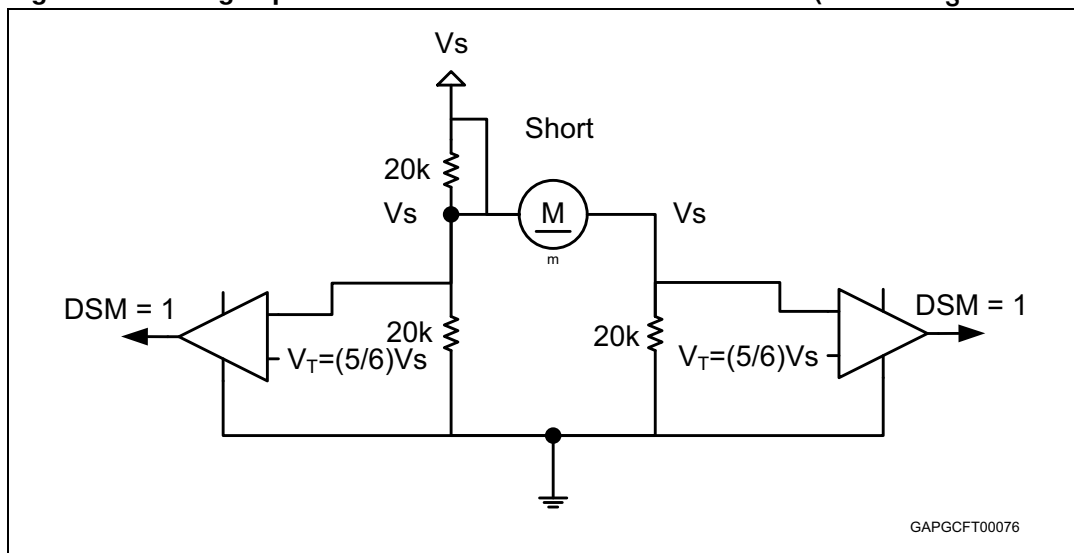

Figure 18. H-bridge open-load detection (short to ground detected)

Figure 19. H-bridge open-load detection with H-OLTH HIGH = '1' (short to  $V_s$  detected)

### 3.20 Programmable cross current protection

Both external MOSFET transistors in one half-bridge are disabled for the cross-current protection time ( $t_{CCP}$ ) after one MOSFET inside this halfbridge is switched off to prevent current flowing from the high-side to the low-side MOSFET.

The cross current protection time  $t_{CCP}$  can be programmed by SPI using bits COPT<3:0>.

Table 27. Cross-current protection time

COPT<3>	COPT<2>	COPT<1>	COPT<0>	Min	Typ	Max	unit
0	0	0	0	150	250	360	ns
0	0	0	1	390	500	670	ns
0	0	1	0	590	750	980	ns
0	0	1	1	800	1000	1280	ns
0	1	0	0	1000	1250	1600	ns
0	1	0	1	1210	1500	1910	ns
0	1	1	0	1420	1750	2220	ns
0	1	1	1	1630	2000	2540	ns
1	0	0	0	1830	2250	2850	ns
1	0	0	1	2050	2500	3120	ns
1	0	1	0	2250	2750	3450	ns
1	0	1	1	2460	3000	3760	ns
1	1	0	0	2660	3250	4100	ns
1	1	0	1	2880	3500	4370	ns
1	1	1	0	3080	3750	4680	ns
1	1	1	1	3200	4000	5000	ns

### 3.21 Controller of electrochromic glass

The voltage of an electrochromic element connected at pin ECV can be controlled to a target value, which is set by the bits EC<5:0>. Setting bit ECON enables this function. An on-chip differential amplifier and an external MOS source follower, with its gate connected to pin ECDR, and which drives the electrochrome mirror voltage at pin ECV, form the control loop. The drain of the external MOS transistor is supplied by OUT10. A diode from pin ECV (anode) to pin ECDR (cathode) has been placed on the chip to protect the external MOS source follower. A capacitor of at least 5 nF has to be added to pin ECDR for loop-stability. The target voltage is binary coded with a full-scale range of 1.5 V. If Bit EC\_HV is set to '0', the maximum controller output voltage is clamped to 1.2 V without changing the resolution of bits EC<5:0>.

When programming the ECVLS driver to on-state, the voltage at pin ECV is pulled to ground by a 1.6  $\Omega$  low-side switch until the voltage at pin ECV is less than  $dV_{ECV_{hi}}$  higher than the target voltage (fast discharge). The status of the voltage control loop is reported via SPI. Bit ECV\_VHI is set, if the voltage at pin ECV is higher, whereas Bit ECV\_VNR in the same status register is set, if the voltage at pin ECV is lower than the target value. Both status bits are valid, if they are stable for at least the  $ECV_{HI}/ECV_{NR}$  – filter time and are not latched. Since OUT10 is the output of a high-side driver, it contains the same diagnose functions as the other high-side drivers (e.g. during an overcurrent detection, the control loop is switched off). In electrochrome mode, OUT10 cannot be controlled by PWM mode. For EMS reasons, the loop capacitor at pin ECDR as well as the capacitor between ECV and GND have to be placed to the respective pins as close as possible (see [Figure 20](#) for details).

If the electrochrome element is connected between the pins ECV and ECFD instead between ECV and ground, a negative voltage can be applied to the device by pulling ECFD to a higher value than ECV, which is connected to ground by a  $1.6\ \Omega$  low-side switch. In this mode the voltage at pin ECFD is controlled to the target value defined by the register EC<5:0>. This is done using an on-chip source-follower transistor (see Figure 21 for details). The negative discharge is enabled by setting bit ECND to '1'.

When programming the ECFDLS driver to on-state, the voltage at pin ECFD is pulled to ground by a  $1.6\ \Omega$  low-side switch until the voltage at pin ECFD is less than  $dV_{ECFDhi}$  higher than the target voltage (fast discharge).

During normal (positive) voltage control the low side driver at pin ECFD must be switched on to connect the electrochrome element to ground.

Pin ECDR is pulled resistively ( $R_{ECDRDIS}$ ) to ground while not in electrochrome mode.

**Figure 20. Electrochrome mirror driver with mirror referenced to ground**

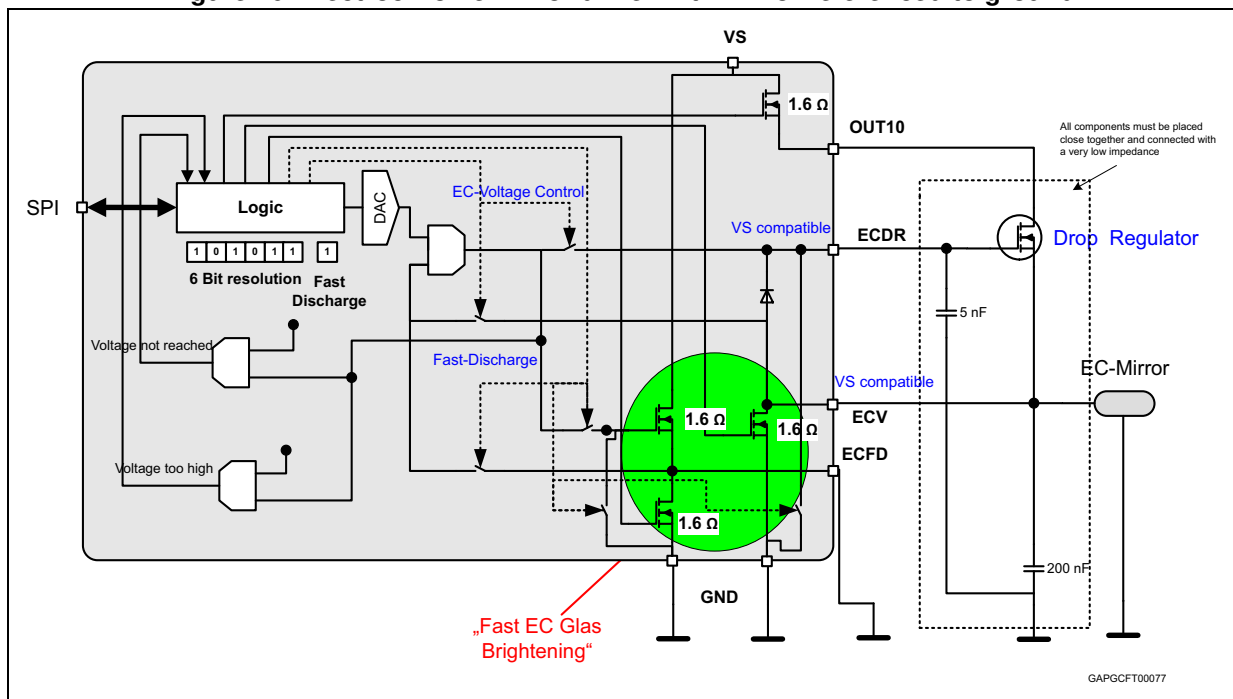
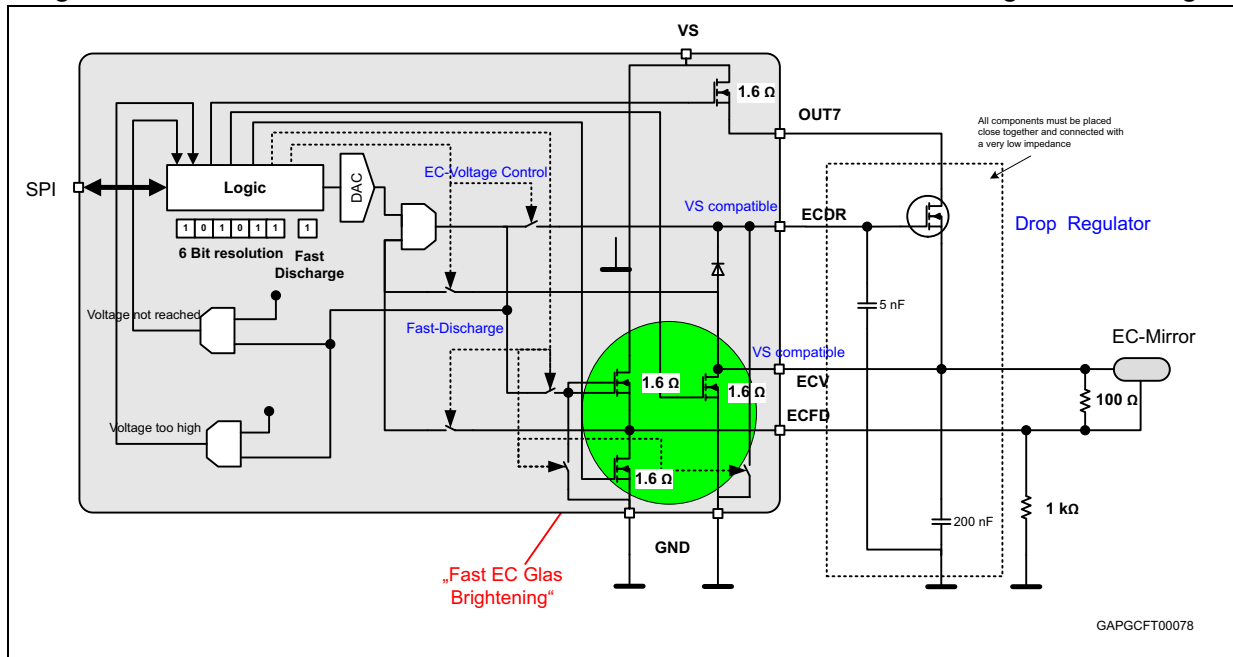

Figure 21. Electrochrome mirror driver with mirror referenced to ECFD for negative discharge



### 3.22 Watchdog

The watchdog monitors the  $\mu\text{C}$  during normal operation within a nominal trigger cycle of 60ms. The watchdog is triggered by toggling the watchdog bit, which restarts the watchdog timer (i.e. content of the watchdog trigger bit has to be inverted). If no watchdog bit inversion has been occurred during the watchdog time-out time  $T_{\text{WDTO}}$  the H-bridge drivers switch into resistive-low condition, all power outputs are switched off, the electrochrome driver is disabled and the device enters standby mode.

## 4 Functional description of the SPI

### 4.1 General description

The SPI complies with Standard ST-SPI Interface Version 3.1.

Its communication is based on a Serial Peripheral Interface structure using CSN (Chip Select Not), DI (Serial Data In), DO (Serial Data Out/Error) and CLK (Serial Clock) signal lines.

#### 4.1.1 Chip Select Not (CSN)

The CSN input pin is used to select the serial interface of this device. When CSN is high, the output pin (DO) is in high impedance state. A low signal wakes up the device and a serial communication can be started. The state when CSN is going low until the rising edge of CSN is called a communication frame.

#### 4.1.2 Serial Data In (DI)

The DI input pin is used to transfer data serially into the device. The data applied to the DI is sampled at the rising edge of the CLK signal. A stuck-at '0' or '1' enters the standby mode.

#### 4.1.3 Serial Clock (CLK)

The CLK input signal provides the timing of the serial interface. The Data Input (DI) is latched at the rising edge of Serial Clock CLK. The SPI can be driven by a micro controller with its SPI peripheral running in following mode: CPOL = 0 and CPHA = 0. Data on Serial Data Out (DO) is shifted out at the falling edge of the serial clock (CLK). The serial clock CLK must be active only during a frame (CSN low). Any other switching of CLK close to any CSN edge could generate set up/hold violations in the SPI logic of the device. The clock monitor counts the number of clock pulses during a communication frame (while CSN is low). If the number of CLK pulses does not correspond to the frame width indicated in the <SPI-frame-ID> (ROM address 03H) the frame is ignored and the <frame error> bit in the <Global Status Byte> is set.

*Note: Due to this safety functionality, daisy chaining the SPI is not possible. Instead, a parallel operation of the SPI bus by controlling the CSN signal of the connected ICs is recommended.*

#### 4.1.4 Serial Data Out (DO)

The data output driver is activated by a logical low level at the CSN input and goes from high impedance to a low or high level depending on the global status bit 7 (Global Error Flag). The content of the selected status or control register is transferred into the data out shift register after the address bits have been transmitted. Each subsequent falling edge of the CLK shifts the next bit out.

#### 4.1.5 SPI communication flow

At the beginning of each communication the master can read the contents of the <SPIframe-ID> register (ROM address 03H) of the slave device.

This 8-bit register indicates the SPI frame length (24 bit) and the availability of additional features. Each communication frame consists of a command byte, which is followed by two data bytes.

The data returned on DO within the same frame always starts with the <Global Status> Byte. It provides general status information about the device. It is followed by two data bytes (i. e. 'In-frame-response').

For write cycles the <Global Status> Byte is followed by the previous content of the addressed register.

Figure 22. Write and read SPI

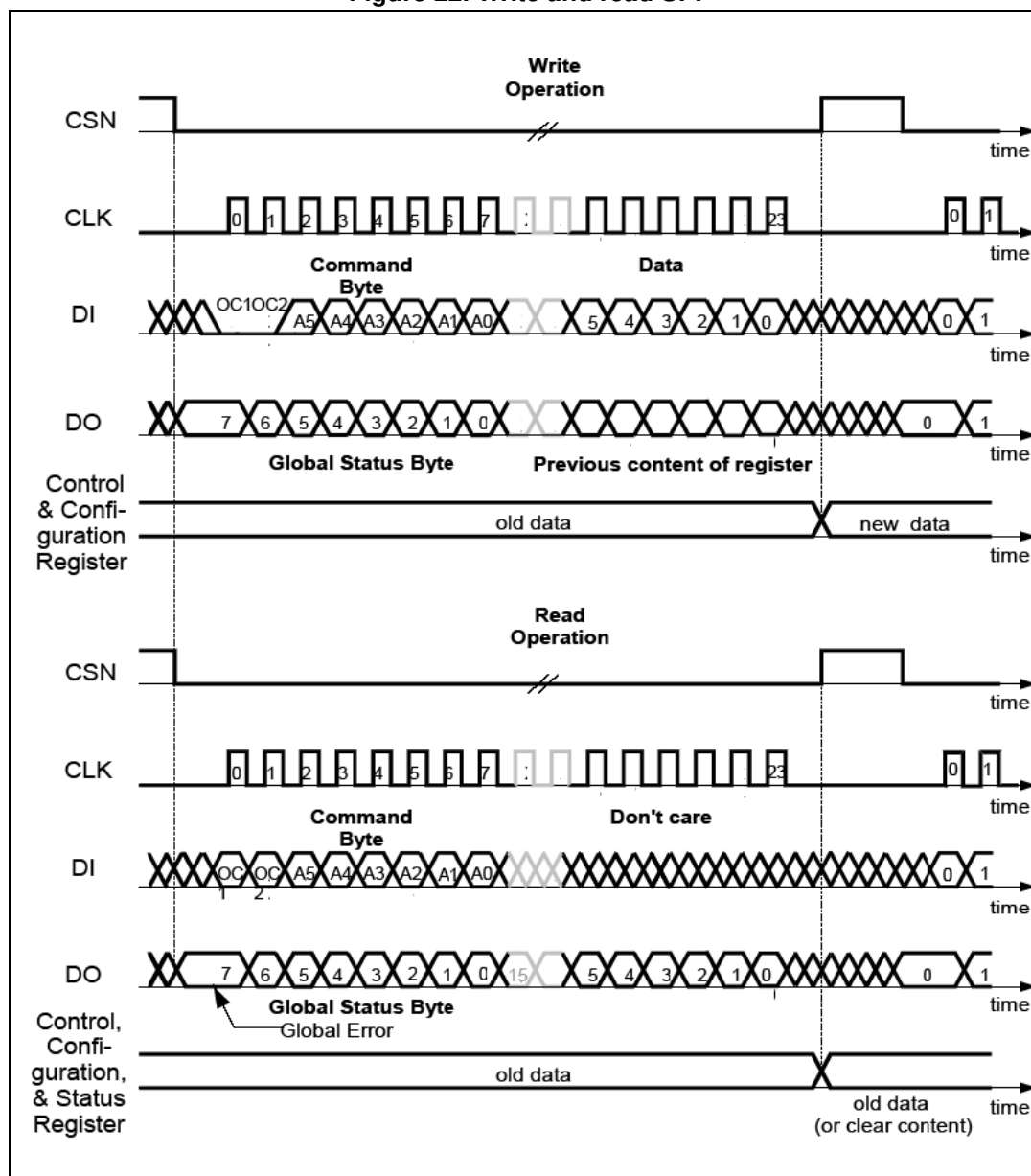

## 4.2 Command byte

Table 28. Command byte

	Command byte								Data byte 1								Data byte 2							
Bit	23	22	21	20	19	18	17	16	15	14	13	12	11	10	9	8	7	6	5	4	3	2	1	0
Name	OC1	OC0	A5	A4	A3	A2	A1	A0	D15	D14	D13	D12	D11	D10	D9	D8	D7	D6	D5	D4	D3	D2	D1	D0

OCx: operation code

Ax: address

Dx: data bit

Each communication frame starts with a command byte. It consists of an operating code which specifies the type of operation (<Read>, <Write>, <Read and Clear>, <Read Device Information>) and a 6 bit address. If less than 6 bits are required, the remaining bits are unused but are reserved.

### 4.2.1 Operation code definition

Table 29. Operation code definition

OC1	OC0	Meaning
0	0	<Write Mode>
0	1	<Read Mode>
1	0	<Read and Clear Mode>
1	1	<Read Device Information>

The <Write Mode> and <Read Mode> operations allow access to the RAM of the device.

A <Read and Clear Mode> operation is used to read a status register and subsequently clear its content.

The <Read Device Information> allows access to the ROM area which contains device related information such as <ID-Header>, <Product Code>, <Silicon Version> and <SPI-frame-ID>.

## 4.3 Device memory map

Table 30. RAM memory map

Address	Name	Access	Content
00h	Control Register 0	Read/write	Device enable, output bridge and H-bridge open-load control
01h	Control Register 1	Read/write	High-side/ low-side and electrochrome control
02h	Control Register 2	Read/write	Bridge recovery mode, PWM and electrochrome setup

**Table 30. RAM memory map (continued)**

Address	Name	Access	Content
03h	Control Register 3	Read/write	High-side recovery mode, PWM setup and current-monitor selection
04h	Control Register 4	Read/write	H-bridge driver control
05h	Control Register 5	Read/write	PWM register
06h	Control Register 6	Read/write	PWM register
10h	Status Register 0	Read/clear	Output bridge overcurrent and H-bridge drain-source diagnosis
11h	Status Register 1	Read/clear	Output bridge and H-bridge open-load diagnosis
12h	Status Register 2	Read/clear	High-side overcurrent/open-load and electrochrome diagnosis
13h	Status Register 3	Read/clear	V <sub>S</sub> and chargepump diagnosis
3Fh	Configuration Reg.	Read/write	Mask bits in global status register

**Table 31. ROM memory map**

Address	Name	Access	Content
00h	ID Header	Read only	4300h (ASSP ST_SPI)
01h	Version	Read only	0300h
02h	Product Code 1	Read only	5200h (82 ST_SPI)
03h	Product Code 2	Read only	4800h (H ST_SPI)
3Eh	SPI-Frame ID.	Read only	4200h SPI-Frame-ID (ST_SPI)



## 5 SPI - control and status registers

**Table 32. Global status byte**

Bit	7	6	5	4	3	2	1	0
Name	GL_ER	CO_ER	C_RESET	TSD	TW	UOV_OC_DS	OL	NR
Reset	0	0	1	0	0	0	0	0

- GL\_ER:** Global Error Flag.  
Failures of bits 6 to 0 are always linked to the Global Error Flag. This flag is set, if at least one of these bits indicates a failure. It is reflected via the DO pin while CSN is held low and no SPI clock signal is applied. This operation does not cause the Communication Error bit in the <Global Status> to be set. The signal TW bit3 and OL bit1 can be masked.
- CO\_ER:** Communication Error.  
If the number of clock pulses during the previous frame is not 24, the frame is ignored and this bit is set.
- C\_RESET:** Chip RESET.  
If a stuck at '1' on input DI during any SPI frame occurs, or if a Power On Reset (VCC monitor) occurs. C\_RESET is reset ('1') with any SPI command. When C\_RESET is active ('0'), the gate drivers are switched off (resistive path to source). After a startup of the circuit C\_RESET is active due to the power-up reset pulse. Therefore, the gate drivers are switched off. They can only be activated after the C\_RESET has been reset by an SPI command.
- TSD:** Thermal shutdown.  
All gate drivers and the charge pump are switched off (resistive path to source). The TSD bit has to be cleared through a read and clear command to reactivate the gate drivers and the chargepump.
- TW:** Thermal Warning.  
This bit can be masked using the configuration register.
- UOV\_OC\_DS:** Logical OR of the filtered undervoltage/overvoltage, chargepump-low, overcurrent of the power outputs and the H-bridge drain-source monitor signals.
- OL:** Open-load.  
Logical OR of the filtered output driver open-load signals. This bit can be masked using the configuration register.
- NR:** Not Ready.  
After switching the device from standby mode to active mode an internal timer is started to allow the chargepump to settle before the outputs can be activated. This bit is cleared automatically after the startup time.

## 5.1 Control Register 0

Table 33. Control Register 0

Bit	Name	Access	Reset	Content
15	OUT1_HS on/off	Read/write	0	The corresponding output driver is activated, if this bit is set. Setting the PWM enable bit, the driver is only switched on, if the PWM timer enables it. An internal cross-current protection prevents, that both the low- and high-side of the half-bridges OUT1-OUT6 are switched on simultaneously.
14	OUT1_LS on/off	Read/write	0	
13	OUT2_HS on/off	Read/write	0	
12	OUT2_LS on/off	Read/write	0	
11	OUT3_HS on/off	Read/write	0	
10	OUT3_LS on/off	Read/write	0	
9	OUT4_HS on/off	Read/write	0	
8	OUT4_LS on/off	Read/write	0	
7	OUT5_HS on/off	Read/write	0	
6	OUT5_LS on/off	Read/write	0	
5	OUT6_HS on/off	Read/write	0	
4	OUT6_LS on/off	Read/write	0	
3	0		0	Reserved (must be set to '0')
2	0		0	
1	0		0	
0	EN	Read/write	0	The device is switched into active mode, if EN is '1'. It enters the standby mode, if the EN bit is '0'. In standby mode all bits are reset.

## 5.2 Control Register 1

Table 34. Control Register 1

Bit	Name	Access	Reset	Content															
15	OUT7_HS1 on/off	Read/write	0	<table border="1"> <thead> <tr> <th>HS1</th> <th>HS2</th> <th>Mode</th> </tr> </thead> <tbody> <tr> <td>0</td> <td>0</td> <td>Off</td> </tr> <tr> <td>0</td> <td>1</td> <td>Low on-resistance</td> </tr> <tr> <td>1</td> <td>0</td> <td>High on-resistance</td> </tr> <tr> <td>1</td> <td>1</td> <td>Off</td> </tr> </tbody> </table>	HS1	HS2	Mode	0	0	Off	0	1	Low on-resistance	1	0	High on-resistance	1	1	Off
HS1	HS2	Mode																	
0	0	Off																	
0	1	Low on-resistance																	
1	0	High on-resistance																	
1	1	Off																	
14	OUT7_HS2 on/off	Read/write	0																
13	OUT8_HS1 on/off	Read/write	0																
12	OUT8_HS2 on/off	Read/write	0																
11	OUT9_HS on/off	Read/write	0	The corresponding output driver is activated, if this bit is set. Setting the PWM enable bit, the driver is only switched on, if the PWM timer enables it.															
10	OUT10_HS on/off	Read/write	0																
9	OUT11_HS on/off	Read/write	0																
8	ECV_LS on/off	Read/write	0																

Table 34. Control Register 1 (continued)

Bit	Name	Access	Reset	Content
7	EC<5>	Read/write	0	The reference voltage for the electrochrome voltage controller at pins ECV and ECFD is binary coded.
6	EC<4>	Read/write	0	
5	EC<3>	Read/write	0	
4	EC<2>	Read/write	0	
3	EC<1>	Read/write	0	
2	EC<0>	Read/write	0	
1	ECON	Read/write	0	The electrochrome control is activated by setting this bit to '1'. This enables the driver at pin ECDR and switches OUT10 directly on ignoring bit OUT10_HS on/off.
0	ECFD_LS on/off	Read/write	0	The corresponding output driver is activated, if this bit is set. Setting the PWM enable bit, the driver is only switched on, if the PWM timer enables it.

### 5.3 Control Register 2

Table 35. Control Register 2

Bit	Name	Access	Reset	Content
15	OUT1_OCR	Read/write	0	Setting this bit to high enables the overcurrent recovery mode for the corresponding output.
14	OUT2_OCR	Read/write	0	
13	OUT3_OCR	Read/write	0	
12	OUT4_OCR	Read/write	0	
11	OUT5_OCR	Read/write	0	
10	OUT6_OCR	Read/write	0	
9	ECV_OCR	Read/write	0	Setting this bit to '1' puts the electrochrome controller into the negative discharge mode.
8	ECND	Read/write	0	
7	OUT1_PWM3	Read/write	0	Setting this bit to '1' enables the PWM mode for the corresponding output.
6	OUT2_PWM1	Read/write	0	
5	OUT3_PWM2	Read/write	0	
4	OUT4_PWM1	Read/write	0	
3	OUT5_PWM2	Read/write	0	
2	OUT6_PWM3	Read/write	0	
1	ECV_PWM4	Read/write	0	Setting this bit to '1' sets the maximum electrochrome controller voltage to 1.5 V (typ.). A '0' clamps it to 1.2V (typ.).
0	ECV_HV	Read/write	0	

### 5.4 Control Register 3

Table 36. Control Register 3

Bit	Name	Access	Reset	Content																														
15	OUT7_OCR	Read/write	0	Setting this bit to high enables the overcurrent recovery mode for the corresponding output.																														
14	OUT8_OCR	Read/write	0																															
13	OUT9_OCR	Read/write	0																															
12	OUT10_OCR	Read/write	0																															
11	OUT11_OCR	Read/write	0																															
10	OUT7_PWM1	Read/write	0	Setting this bit to '1' enables the PWM mode for the corresponding output.																														
9	OUT8_PWM2	Read/write	0																															
8	OUT9_PWM3	Read/write	0																															
7	OUT10_PWM4	Read/write	0																															
6	OUT11_PWM4	Read/write	0																															
5	OCR_FREQ	Read/write	0	This bit defines the overcurrent recovery frequency (0: 1.7kHz (typ.) 1: 3kHz (typ.))																														
4	OV_UV_RD	Read/write	0	If this bit is set, the associated status bit has to be cleared after an overvoltage /undervoltage event to enable the output drivers again.																														
3	CM_SEL<3>	Read/write	0	A current image of the selected binary coded output is multiplexed to the CM output. If a corresponding output does not exist, the current monitor is deactivated (especially '0000').																														
2	CM_SEL<2>	Read/write	0																															
1	CM_SEL<1>	Read/write	0																															
0	CM_SEL<0>	Read/write	0																															
					<table border="1"> <thead> <tr> <th>CM_SEL&lt;3:0&gt;</th> <th>Selected output</th> </tr> </thead> <tbody> <tr> <td>0000</td> <td>3-state</td> </tr> <tr> <td>0001</td> <td>OUT&lt;1&gt;</td> </tr> <tr> <td>0010</td> <td>OUT&lt;2&gt;</td> </tr> <tr> <td>0011</td> <td>OUT&lt;3&gt;</td> </tr> <tr> <td>0100</td> <td>OUT&lt;4&gt;</td> </tr> <tr> <td>0101</td> <td>OUT&lt;5&gt;</td> </tr> <tr> <td>0110</td> <td>OUT&lt;6&gt;</td> </tr> <tr> <td>0111</td> <td>OUT&lt;7&gt;</td> </tr> <tr> <td>1000</td> <td>OUT&lt;8&gt;</td> </tr> <tr> <td>1001</td> <td>OUT&lt;9&gt;</td> </tr> <tr> <td>1010</td> <td>OUT&lt;10&gt;</td> </tr> <tr> <td>1011</td> <td>OUT&lt;11&gt;</td> </tr> <tr> <td>1100</td> <td>Reserved</td> </tr> <tr> <td>1101-1111</td> <td>3-state</td> </tr> </tbody> </table>	CM_SEL<3:0>	Selected output	0000	3-state	0001	OUT<1>	0010	OUT<2>	0011	OUT<3>	0100	OUT<4>	0101	OUT<5>	0110	OUT<6>	0111	OUT<7>	1000	OUT<8>	1001	OUT<9>	1010	OUT<10>	1011	OUT<11>	1100	Reserved	1101-1111
CM_SEL<3:0>	Selected output																																	
0000	3-state																																	
0001	OUT<1>																																	
0010	OUT<2>																																	
0011	OUT<3>																																	
0100	OUT<4>																																	
0101	OUT<5>																																	
0110	OUT<6>																																	
0111	OUT<7>																																	
1000	OUT<8>																																	
1001	OUT<9>																																	
1010	OUT<10>																																	
1011	OUT<11>																																	
1100	Reserved																																	
1101-1111	3-state																																	



## 5.5 Control Register 4

Table 37. Control Register 4

Bit	Name	Access	Reset	Content
15	SLEW<4>	Read/write	0	Binary coded Slew Rate Current of the H-Bridge
14	SLEW<3>	Read/write	0	
13	SLEW<2>	Read/write	0	
12	SLEW<1>	Read/write	0	
11	SLEW<0>	Read/write	0	
10	H-OLTH HIGH	Read/write	0	H-bridge OL high threshold ( $5/6 * V_G$ ) select
9	OL_H1L2	Read/write	0	Test open-load condition between H1 and L2
8	OL_H2L1	Read/write	0	Test open-load condition between H2 and L1
7	SD	Read/write	0	Slow decay
6	SDS	Read/write	0	Slow decay single
5	COPT<3>	Read/write	1	Cross-current protection time (default 4000ns)
4	COPT<2>	Read/write	1	
3	COPT<1>	Read/write	1	
2	COPT<0>	Read/write	1	
1	DIAG<1>	Read/write	0	Drain-source monitoring threshold voltage
0	DIAG<0>	Read/write	0	

## 5.6 Control Register 5

Table 38. Control Register 5

Bit	Name	Access	Reset	Content
15	0		0	Reserved (must be set to '0')
14	PWM2<6>	Read/write	0	Binary coded PWM2 on-duty-cycle
13	PWM2<5>	Read/write	0	
12	PWM2<4>	Read/write	0	
11	PWM2<3>	Read/write	0	
10	PWM2<2>	Read/write	0	
9	PWM2<1>	Read/write	0	
8	PWM2<0>	Read/write	0	
7	PWMFREQ	Read/write	0	PWM-frequency (0: 122 Hz or 1: 244 Hz)

**Table 38. Control Register 5 (continued)**

Bit	Name	Access	Reset	Content
6	PWM1<6>	Read/write	0	Binary coded PWM1 on-duty-cycle
5	PWM1<5>	Read/write	0	
4	PWM1<4>	Read/write	0	
3	PWM1<3>	Read/write	0	
2	PWM1<2>	Read/write	0	
1	PWM1<1>	Read/write	0	
0	PWM1<0>	Read/write	0	

## 5.7 Control Register 6

**Table 39. Control Register 6**

Bit	Name	Access	Reset	Content
15	0		0	Reserved (must be set to '0')
14	PWM4<6>	Read/write	0	Binary coded PWM4 on-duty-cycle
13	PWM4<5>	Read/write	0	
12	PWM4<4>	Read/write	0	
11	PWM4<3>	Read/write	0	
10	PWM4<2>	Read/write	0	
9	PWM4<1>	Read/write	0	
8	PWM4<0>	Read/write	0	
7	0		0	Reserved (must be set to '0')
6	PWM3<6>	Read/write	0	Binary coded PWM3 on-duty-cycle
5	PWM3<5>	Read/write	0	
4	PWM3<4>	Read/write	0	
3	PWM3<3>	Read/write	0	
2	PWM3<2>	Read/write	0	
1	PWM3<1>	Read/write	0	
0	PWM3<0>	Read/write	0	

## 5.8 Configuration Register

Table 40. Configuration Register

Bit	Name	Access	Reset	Content
15	0		0	Reserved (must be set to '0')
14	0		0	
13	0		0	
12	0		0	
11	0		0	
10	0		0	
9	0		0	
8	0		0	
7	0		0	
6	HEN	Read/write	0	A '1' enables the H-bridge
5	MASK OL HS1	Read/write	0	Masks open-load of high-side 1 to global status register
4	MASK OL LS1	Read/write	0	Masks open-load of low-side 1 to global status register
3	MASK TW	Read/write	0	Masks thermo warning to global status register
2	MASK EC OL	Read/write	0	Masks open-load of ECV, ECFDHS, ECFDLS and OUT10
1	MASK OL	Read/write	0	Masks all open-load diagnosis to global status register
0	WD	Read/write	0	Watchdog

## 5.9 Status Register 0

Table 41. Status Register 0

Bit	Name	Access	Content
15	OUT1_HS OC	Read/clear	Overcurrent status bit of the corresponding output driver. A '1' indicates that an overcurrent has occurred.
14	OUT1_LS OC	Read/clear	
13	OUT2_HS OC	Read/clear	
12	OUT2_LS OC	Read/clear	
11	OUT3_HS OC	Read/clear	
10	OUT3_LS OC	Read/clear	
9	OUT4_HS OC	Read/clear	
8	OUT4_LS OC	Read/clear	
7	OUT5_HS OC	Read/clear	
6	OUT5_LS OC	Read/clear	
5	OUT6_HS OC	Read/clear	
4	OUT6_LS OC	Read/clear	

Table 41. Status Register 0 (continued)

Bit	Name	Access	Content
3	DS_MON_HS<2>	Read/clear	DS-Monitoring bit. A '1' indicates that a drain-monitoring event (short-circuit or open-load) has occurred.
2	DS_MON_HS<1>	Read/clear	
1	DS_MON_LS<2>	Read/clear	
0	DS_MON_LS<1>	Read/clear	

## 5.10 Status Register 1

Table 42. Status Register 1

Bit	Name	Access	Content
15	OUT1_HS OL	Read/clear	Open-Load status bit of the corresponding output driver. A '1' indicates that an open-load event has occurred.
14	OUT1_LS OL	Read/clear	
13	OUT2_HS OL	Read/clear	
12	OUT2_LS OL	Read/clear	
11	OUT3_HS OL	Read/clear	
10	OUT3_LS OL	Read/clear	
9	OUT4_HS OL	Read/clear	
8	OUT4_LS OL	Read/clear	
7	OUT5_HS_OL	Read/clear	
6	OUT5_LS OL	Read/clear	
5	OUT6_HS OL	Read/clear	
4	OUT6_LS OL	Read/clear	
3	0	Read	Reserved
2	0	Read	
1	0	Read	
0	0	Read	



## 5.11 Status Register 2

Table 43. Status Register 2

Bit	Name	Access	Content
15	OUT7 OC	Read/clear	Overcurrent and open-load status bit of the corresponding output driver
14	OUT7 OL	Read/clear	
13	OUT8 OC	Read/clear	
12	OUT8 OL	Read/clear	
11	OUT9 OC	Read/clear	
10	OUT9 OL	Read/clear	
9	OUT10 OC	Read/clear	
8	OUT10 OL	Read/clear	
7	OUT11 OC	Read/clear	
6	OUT11 OL	Read/clear	
5	ECV OC	Read/clear	
4	ECV OL	Read/clear	
3	VS UV	Read/clear	$V_S$ undervoltage and overvoltage status bit.
2	VS OV	Read/clear	
1	ECV_VNR	Read/clear	Electrochrome voltage not reached / too high status bits
0	ECV_VHI	Read/clear	

## 5.12 Status Register 3

Table 44. Status Register 3

Bit	Name	Access	Content
15	0	Read	Reserved
14	0	Read	
13	0	Read	
12	0	Read	
11	0	Read	
10	0	Read	
9	0	Read	
8	0	Read	
7	0	Read	
6	0	Read	

Table 44. Status Register 3 (continued)

Bit	Name	Access	Content
5	ECFDH OC	Read/clear	Overcurrent and open-load status bit of the corresponding output driver
4	ECFDH OL	Read/clear	
3	ECFD OC	Read/clear	
2	ECFD OL	Read/clear	
1	0	Read	Reserved
0	CP LOW	Read/clear	This bit indicates, that the charge pump voltage is too low

## 6 Package and packing information

### 6.1 ECOPACK® package

In order to meet environmental requirements, ST offers these devices in different grades of ECOPACK® packages, depending on their level of environmental compliance. ECOPACK® specifications, grade definitions and product status are available at: [www.st.com](http://www.st.com). ECOPACK® is an ST trademark.

### 6.2 TQFP-64 mechanical data

Table 45. TQFP-64 mechanical data

Symbol	Millimeters		
	Min.	Typ.	Max.
A			1,20
A1	0,05		0,15
A2	0,95	1,00	1,05
b	0,17	0,22	0,27
c	0,09		0,20
D	11,80	12,00	12,20
D1	9,80	10,00	10,20
D2 <sup>(1)</sup>	5,85	6,00	6,15
D3		7,50	
E	11,80	12,00	12,20
E1	9,80	10,00	10,20
E2 <sup>(1)</sup>	5,85	6,00	6,15
E3		7,50	
e		0,50	
L	0,45	0,60	0,75
L1		1,00	
k	0°	3,50°	7°
ccc			0,08

1. The size of exposed pads is variable depending on lead frame design and pad size end user should verify "D2" and "E2" dimensions for each device application

Figure 23. TQFP-64 package dimension

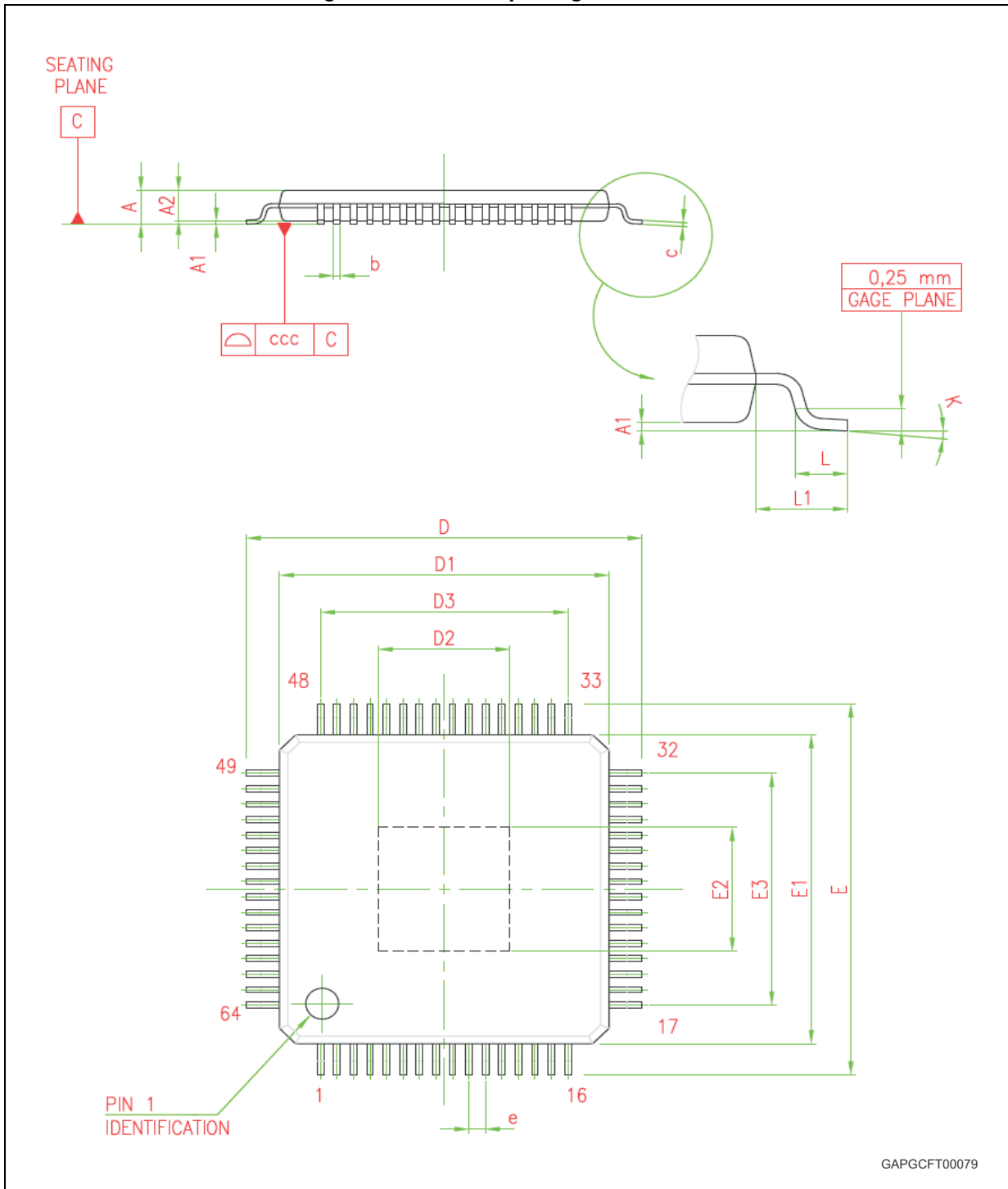

GAPGCF00079



Figure 25. TQFP-64 power lead-less tray shipment (no suffix) (part 2)

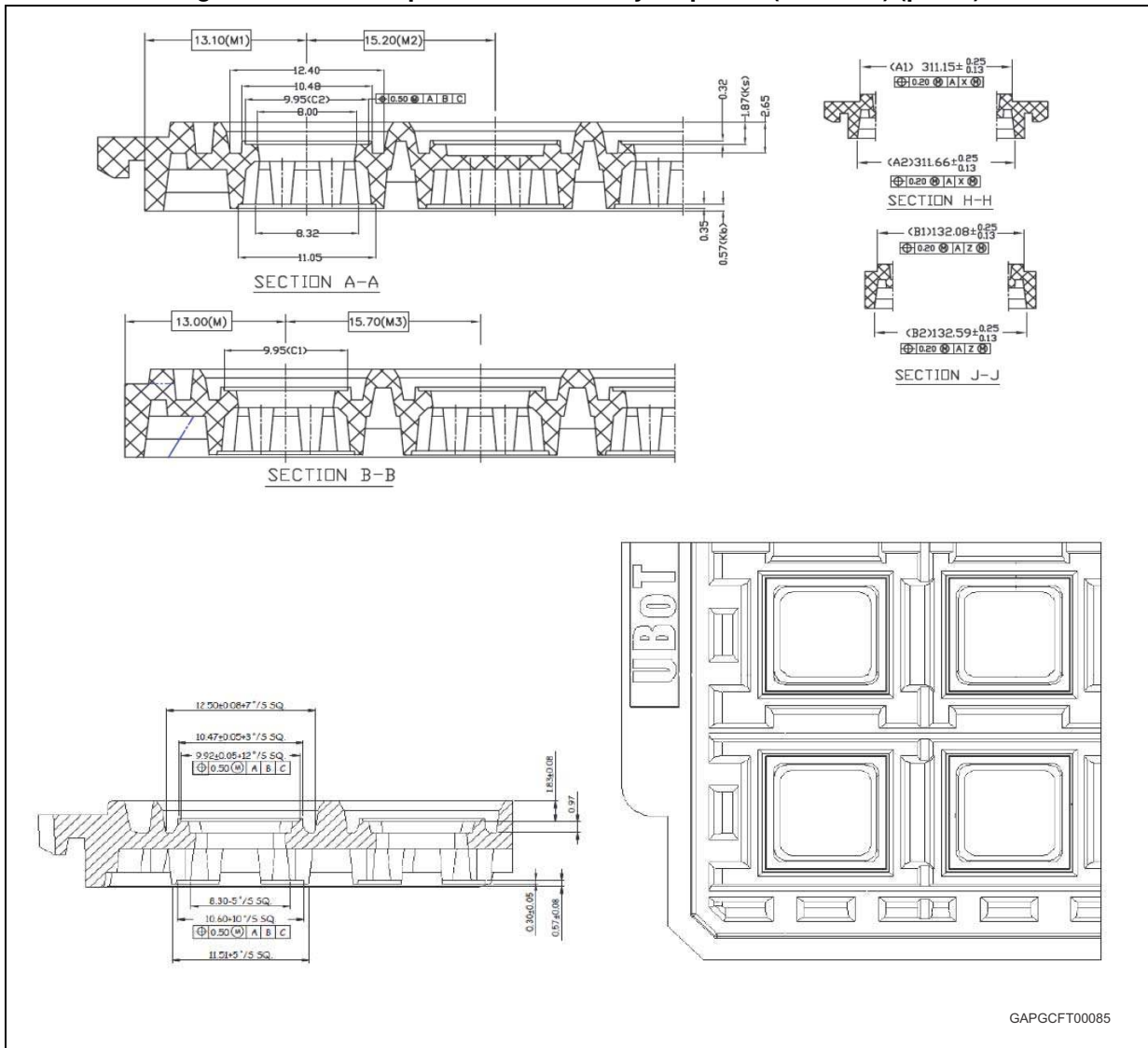
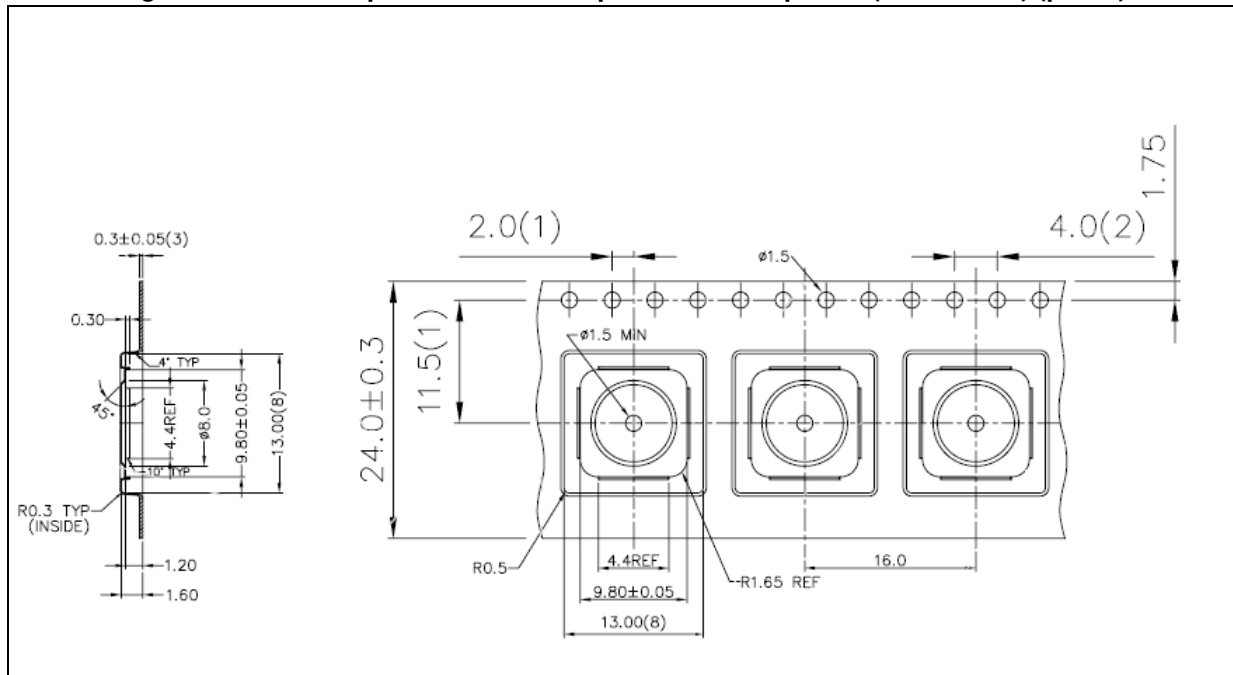



Figure 27. TQFP-64 power lead-less tape and reel shipment (suffix "TR") (part 2)





## 7 Revision history

**Table 46. Document revision history**

Date	Revision	Change
20-Dec-2010	1	Initial release
10-Mar-2011	2	<p>Updated <a href="#">Datasheet - production data</a> list.</p> <p>Updated following tables:</p> <ul style="list-style-type: none"> <li>– <a href="#">Table 1: Device summary</a></li> <li>– <a href="#">Table 2: Pin definitions and functions</a>: GH2, SH2, GL2, SL2: updated functions</li> <li>– <a href="#">Table 7: Package thermal impedance</a></li> <li>– <a href="#">Table 8: Supply</a>: <math>I_{VCC(stby)}</math>: set max value to TBD</li> <li>– <a href="#">Table 13: Power outputs switching times</a>: <math>t_{dHL}</math>, <math>t_{dLH}</math>: updated parameter</li> <li>– <a href="#">Table 31: ROM memory map</a>: updated content for address 01h</li> <li>– <a href="#">Table 40: Configuration Register</a>: bit 5, 4, 3 and 1: updated contents</li> </ul> <p>Updated following sections:</p> <ul style="list-style-type: none"> <li>– <a href="#">Section 3.5: Overvoltage and undervoltage detection at VS</a></li> <li>– <a href="#">Section 3.19: H-bridge monitoring in off-mode</a></li> <li>– <a href="#">Section 3.20: Programmable cross current protection</a></li> </ul> <p>Updated <a href="#">Figure 21: Electrochrome mirror driver with mirror referenced to ECFD for negative discharge</a></p> <p>Added <a href="#">Section 6.3: TQFP-64 packing information</a></p>

Table 46. Document revision history (continued)

Date	Revision	Change
06-Apr-2011	3	<p><i>Table 8: Supply:</i></p> <ul style="list-style-type: none"> <li>– <math>I_{VCC(stby)}</math>: changed TBD at 6 <math>\mu</math>A and updated <math>V_{CC}</math> from 5.1 V to 5.0 V; added test condition for <math>V_{CC} = 5.3</math> V</li> </ul> <p><i>Table 9: Overvoltage and undervoltage detection:</i></p> <ul style="list-style-type: none"> <li>– <math>V_{VCCRESHU}</math>, <math>V_{VCCRESHD}</math>: updated max value</li> <li>– <math>V_{VCCRES}</math> hysth: updated test condition</li> </ul> <p><i>Table 12: On-resistance:</i></p> <ul style="list-style-type: none"> <li>– <math>I_{QLL}</math>: updated max value for OUT1-6 and typ, min, max for ECFD</li> </ul> <p><i>Table 13: Power outputs switching times:</i></p> <ul style="list-style-type: none"> <li>– <math>t_{d ON H}</math>: updated min value for all OUT except OUT<sub>7,8</sub></li> <li>– <math>dV_{OUT}/dt</math>: updated min value</li> </ul> <p><i>Table 15: Gate drivers for the external Power-MOS (H-bridge):</i></p> <ul style="list-style-type: none"> <li>– <math>I_{pdGSHx}</math>: removed row</li> <li>– <math>R_{GHx}</math>, <math>R_{GLx}</math>: updated min, typ and max values</li> </ul> <p><i>Table 18: Open-load monitoring:</i></p> <ul style="list-style-type: none"> <li>– <math>V_{ODSL}</math>: added min and max values, updated typ value</li> <li>– <math>V_{ODSH}</math>: added min and max values</li> </ul> <p><i>Table 19: Electrochrome mirror driver:</i></p> <ul style="list-style-type: none"> <li>– <math>DNL_{ECV}</math>, <math>DNL_{ECFD}</math>: added note</li> </ul> <p><i>Table 20: Delay time from Standby to Active mode:</i></p> <ul style="list-style-type: none"> <li>– <math>t_{set}</math>: updated max value</li> </ul>

Table 46. Document revision history (continued)

Date	Revision	Change
16-Sep-2011	4	<p>Updated <a href="#">Table 1: Device summary</a></p> <p><a href="#">Table 9: Overvoltage and undervoltage detection</a></p> <ul style="list-style-type: none"> <li>- <math>V_{SUV\ OFF}</math>: updated min value</li> </ul> <p><a href="#">Table 11: Charge pump</a></p> <ul style="list-style-type: none"> <li>- <math>V_{CP}</math>: updated test condition and max value</li> <li>- <math>I_{CP}</math>: updated max value</li> <li>- <math>I_{CP\ lim}</math>: updated min value</li> </ul> <p><a href="#">Table 12: On-resistance</a></p> <ul style="list-style-type: none"> <li>- <math>I_{QLH}</math>: updated min value</li> <li>- <math>I_{QLL}</math>: updated test condition</li> </ul> <p><a href="#">Table 13: Power outputs switching times</a></p> <ul style="list-style-type: none"> <li>- <math>t_{d\ OFF\ L}</math>: updated max value</li> <li>- <math>t_{d\ HL}</math>, <math>t_{d\ LH}</math>: updated min value</li> </ul> <p><a href="#">Table 14: Current monitoring</a></p> <ul style="list-style-type: none"> <li>- <math> I_{OC1} </math>, <math> I_{OC6} </math>, <math> I_{OC4} </math>, <math> I_{OC5} </math>: updated max values</li> <li>- <math> I_{OLD1} </math>, <math> I_{OLD6} </math>: updated min value</li> </ul> <p><a href="#">Table 15: Gate drivers for the external Power-MOS (H-bridge)</a></p> <ul style="list-style-type: none"> <li>- <math>R_{GHx}</math>, <math>R_{GLx}</math>: updated min, typ and max values</li> </ul> <p><a href="#">Table 16: Gate drivers for the external Power-MOS switching times</a></p> <ul style="list-style-type: none"> <li>- <math>I_{GHxrmax}</math>, <math>I_{GHxfmax}</math>, <math>dI_{GHxr}</math>, <math>dI_{GHxf}</math>: updated parameters; updated min, typ and max values</li> <li>- <math>t_{CCP}</math>: updated max value</li> <li>- <math>t_{CCPacc}</math>: removed row</li> </ul> <p>- <a href="#">Table 17: Drain source monitoring</a>:</p> <ul style="list-style-type: none"> <li>- <math>V_{SCd1}</math>, <math>V_{SCd2}</math>, <math>V_{SCd3}</math>, <math>V_{SCd4}</math>: updated test conditions, min and max values</li> <li>- <math>t_{SCd}</math>: updated min, typ and max values</li> </ul> <p>- <a href="#">Table 20: Delay time from Standby to Active mode</a></p> <ul style="list-style-type: none"> <li>- <math>t_{set}</math>: updated min, typ and max values</li> </ul> <p><a href="#">Table 21: Inputs: DI, CSN, CLK, DIR and PWMH</a></p> <ul style="list-style-type: none"> <li>- <math>R_{CSN\ in}</math>, <math>R_{CLK\ in}</math>, <math>R_{DI\ in}</math>, <math>R_{DIR}</math>, <math>R_{PWMH}</math>: updated min, typ and max values</li> </ul> <p>Updated <a href="#">Table 27: Cross-current protection time</a></p>
22-Sep-2013	5	Updated Disclaimer.
23-12-2016	6	<p>Updated cover page:</p> <ul style="list-style-type: none"> <li>- Automotive in the title</li> <li>- Feature: AEC-Q100 qualified</li> </ul> <p>Updated <a href="#">Figure 27: TQFP-64 power lead-less tape and reel shipment (suffix "TR") (part 2)</a></p> <p>Updated Disclaimer</p>

**IMPORTANT NOTICE – PLEASE READ CAREFULLY**

STMicroelectronics NV and its subsidiaries ("ST") reserve the right to make changes, corrections, enhancements, modifications, and improvements to ST products and/or to this document at any time without notice. Purchasers should obtain the latest relevant information on ST products before placing orders. ST products are sold pursuant to ST's terms and conditions of sale in place at the time of order acknowledgement.

Purchasers are solely responsible for the choice, selection, and use of ST products and ST assumes no liability for application assistance or the design of Purchasers' products.

No license, express or implied, to any intellectual property right is granted by ST herein.

Resale of ST products with provisions different from the information set forth herein shall void any warranty granted by ST for such product.

ST and the ST logo are trademarks of ST. All other product or service names are the property of their respective owners.

Information in this document supersedes and replaces information previously supplied in any prior versions of this document.

© 2016 STMicroelectronics – All rights reserved