



1000W Power Supply with Single Output

RSP-1000 series

Dimension

L	W	H
295	127	41 (1U) mm
11.6	5	1.61(1U) inch



Features

- Universal AC input / Full range
- Built-in active PFC function
- High efficiency up to 90%
- Forced air cooling by built-in DC fan
- Output voltage programmable
- Active current sharing up to 4000W (3+1)
- Built-in remote ON-OFF control / remote sense / auxiliary power / DC OK signal
- Protections: Short circuit / Overload / Over voltage / Over temperature
- Optional conformal coating
- 5 years warranty

Applications

- Factory control or automation apparatus
- Test and measurement instrument
- Laser related machine
- Burn-in facility
- RF application

GTIN CODE

MW Search: <https://www.meanwell.com/serviceGTIN.aspx>

Description

RSP-1000 is a 1KW single output enclosed type AC/DC power supply with 1U low profile. This series operates for 90~264VAC input voltage and offers the models with the DC output mostly demanded from the industry. Each model is cooled by the built-in fan with fan speed control, working for the temperature up to 60°C. Moreover, RSP-1000 provides vast design flexibility by equipping various built-in functions such as the output programming, active current sharing, remote ON-OFF control, auxiliary power, etc.

Model Encoding / Order Information

RSP - 1000 - 24

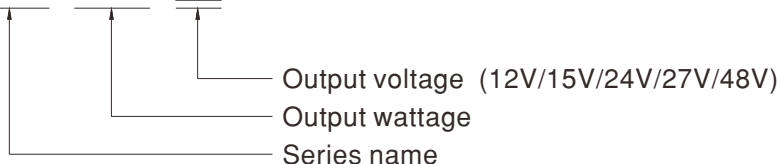

SPECIFICATION

MODEL		RSP-1000-12	RSP-1000-15	RSP-1000-24	RSP-1000-27	RSP-1000-48	
OUTPUT	DC VOLTAGE	12V	15V	24V	27V	48V	
	RATED CURRENT	60A	50A	40A	37A	21A	
	CURRENT RANGE	0 ~ 60A	0 ~ 50A	0 ~ 40A	0 ~ 37A	0 ~ 21A	
	RATED POWER	720W	750W	960W	999W	1008W	
	RIPPLE & NOISE (max.) Note.2	150mVp-p	150mVp-p	150mVp-p	150mVp-p	150mVp-p	
	VOLTAGE ADJ. RANGE	10 ~ 13.5V	13.5 ~ 16.5V	20 ~ 26.4V	24 ~ 30V	43 ~ 55V	
	VOLTAGE TOLERANCE Note.3	±1.0%	±1.0%	±1.0%	±1.0%	±1.0%	
	LINE REGULATION	±0.5%	±0.5%	±0.5%	±0.5%	±0.5%	
	LOAD REGULATION	±0.5%	±0.5%	±0.5%	±0.5%	±0.5%	
	SETUP, RISE TIME	300ms, 50ms at full load					
HOLD UP TIME (Typ.)	16ms/230VAC 16ms/115VAC at full load						
INPUT	VOLTAGE RANGE Note.4	90 ~ 264VAC	127 ~ 370VDC				
	FREQUENCY RANGE	47 ~ 63Hz					
	POWER FACTOR (Typ.)	0.95/230VAC	0.98/115VAC at full load				
	EFFICIENCY (Typ.)	83%	85%	88%	88%	90%	
	AC CURRENT (Typ.)	12A/115VAC	6A/230VAC				
	INRUSH CURRENT (Typ.)	25A/115VAC	40A/230VAC				
	LEAKAGE CURRENT	<2.0mA / 240VAC					
PROTECTION	OVERLOAD	105 ~ 125% rated output power Protection type : Constant current limiting, recovers automatically after fault condition is removed					
	OVER VOLTAGE	13.8 ~ 16.8V	17 ~ 20.5V	27.6 ~ 32.4V	31 ~ 36.5V	56.6 ~ 66.2V	
	OVER TEMPERATURE	Shut down o/p voltage, recovers automatically after temperature goes down					
FUNCTION	OUTPUT VOLTAGE PROGRAMMABLE(PV)	Adjustment of output voltage is allowable to 40 ~ 110% of nominal output voltage. Please refer to the Function Manual.					
	CURRENT SHARING	Up to 4000W or (3+1) units. Please refer to the Function Manual.					
	AUXILIARY POWER	5V @ 0.5A (+5%, -8%)					
	REMOTE ON-OFF CONTROL	Power ON : short Power OFF : open. Please refer to the Function Manual.					
	REMOTE SENSE	Compensate voltage drop on the load wiring up to 0.5V. Please refer to the Function Manual.					
	DC OK SIGNAL	The TTL signal out, PSU turn on = 0 ~ 1V ; PSU turn off = 3.3 ~ 5.6V. Please refer to the Function Manual.					
ENVIRONMENT	WORKING TEMP.	-20 ~ +60°C (Refer to "Derating Curve")					
	WORKING HUMIDITY	20 ~ 90% RH non-condensing					
	STORAGE TEMP., HUMIDITY	-40 ~ +85°C, 10 ~ 95% RH non-condensing					
	TEMP. COEFFICIENT	±0.02%/°C (0 ~ 50°C)					
	VIBRATION	10 ~ 500Hz, 2G 10min./1cycle, 60min. each along X, Y, Z axes					
SAFETY & EMC (Note 5)	SAFETY STANDARDS	UL62368-1, CSA C22.2 No. 62368-1, TUV BS EN/EN62368-1, CCC GB4943.1, BSMI CNS14336-1, AS/NZS62368.1, IS13252(Part1)/IEC60950-1, EAC TP TC 004 approved					
	WITHSTAND VOLTAGE	I/P-O/P:3KVAC I/P-FG:2KVAC O/P-FG:0.5KVAC					
	ISOLATION RESISTANCE	I/P-O/P, I/P-FG, O/P-FG:100M Ohms / 500VDC / 25°C / 70% RH					
	EMC EMISSION	Parameter	Standard			Test Level / Note	
		Conducted	BS EN/EN55032 (CISPR32)			Class B	
		Radiated	BS EN/EN55032 (CISPR32)			Class A	
		Harmonic Current	BS EN/EN61000-3-2			-----	
	EMC IMMUNITY	Voltage Flicker	BS EN/EN61000-3-3			-----	
		BS EN/EN55035, BS EN/EN61000-6-2, CCC GB17625.1, GB/T9254, BSMI CNS13438					
		Parameter	Standard			Test Level / Note	
		ESD	BS EN/EN61000-4-2			Level 3, 8KV air ; Level 2, 4KV contact	
		Radiated	BS EN/EN61000-4-3			Level 3	
		EFT / Burst	BS EN/EN61000-4-4			Level 3	
Surge		BS EN/EN61000-4-5			Level 4, 4KV/Line-Earth ; Level 3, 2KV/Line-Line		
Conducted		BS EN/EN61000-4-6			Level 3		
Magnetic Field	BS EN/EN61000-4-8			Level 4			
Voltage Dips and Interruptions	BS EN/EN61000-4-11			>95% dip 0.5 periods, 30% dip 25 periods, >95% interruptions 250 periods			
OTHERS	MTBF	939.4K hrs min. Telcordia SR-332 (Bellcore) ; 116.5K hrs min. MIL-HDBK-217F (25°C)					
	DIMENSION	295*127*41mm (L*W*H)					
	PACKING	1.95Kg; 6pcs/12.7Kg/1.15CUFT					
NOTE	<p>1. All parameters NOT specially mentioned are measured at 230VAC input, rated load and 25°C of ambient temperature.</p> <p>2. Ripple & noise are measured at 20MHz of bandwidth by using a 12" twisted pair-wire terminated with a 0.1uf & 47uf parallel capacitor.</p> <p>3. Tolerance : includes set up tolerance, line regulation and load regulation.</p> <p>4. Derating may be needed under low input voltages. Please check the derating curve for more details.</p> <p>5. The power supply is considered a component which will be installed into a final equipment. All the EMC tests are been executed by mounting the unit on a 360mm*360mm metal plate with 1mm of thickness. The final equipment must be re-confirmed that it still meets EMC directives. For guidance on how to perform these EMC tests, please refer to "EMI testing of component power supplies." (as available on http://www.meanwell.com)</p> <p>6. The ambient temperature derating of 3.5°C/1000m with fanless models and of 5°C/1000m with fan models for operating altitude higher than 2000m(6500ft).</p> <p>※ Product Liability Disclaimer : For detailed information, please refer to https://www.meanwell.com/serviceDisclaimer.aspx</p>						

Block Diagram

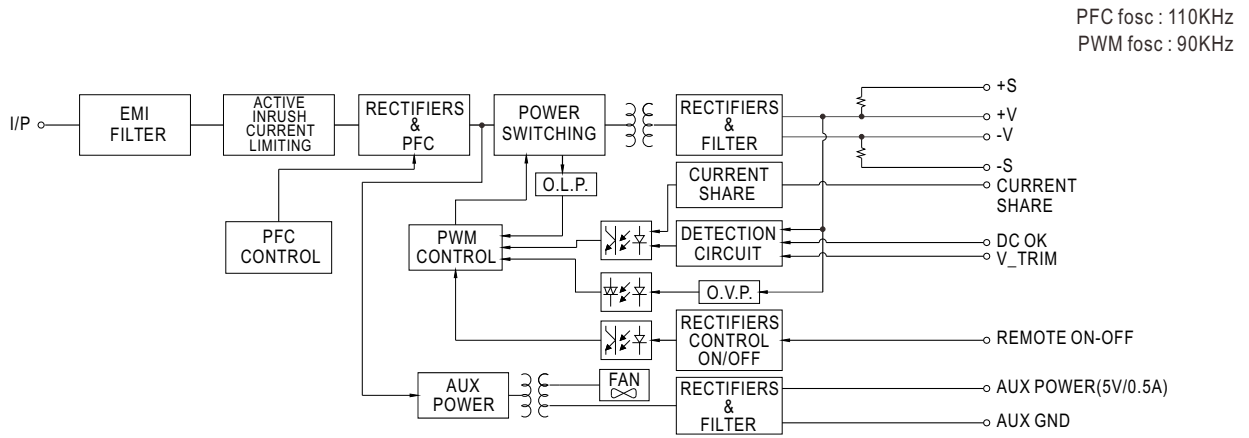

Static Characteristics

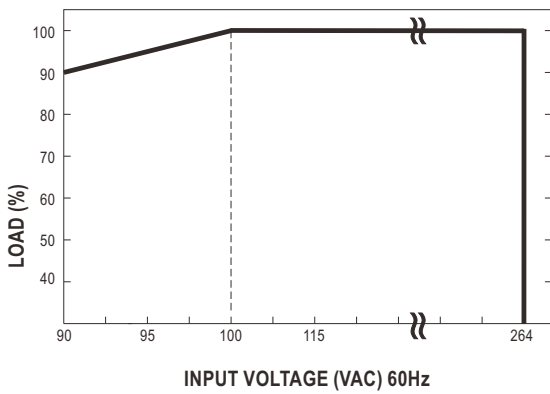

INPUT \ MODEL	12V	15V	24V	27V	48V
100~264VAC	720W 60A	750W 50A	960W 40A	999W 37A	1008W 21A
90VAC	648W 54A	675W 45A	864W 36A	899.1W 33.3A	907.2W 18.9A

Derating Curve

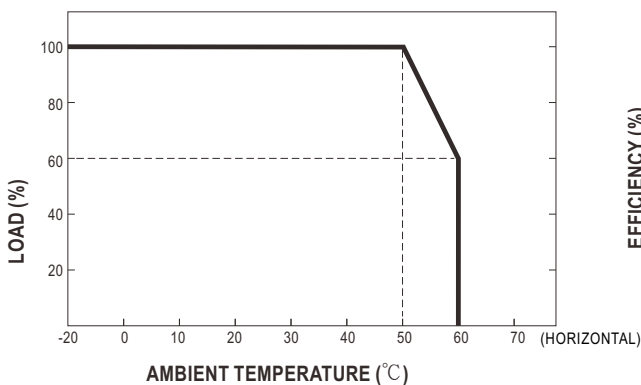

Efficiency vs Load (48V Model)

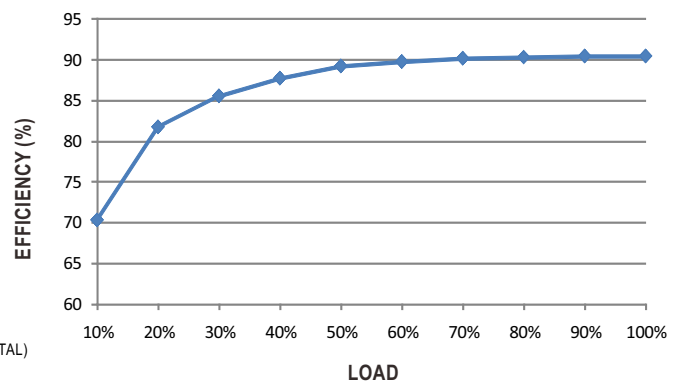

※ The curve above is measured at 230VAC.

Function Manual

1. Remote Sense

※ The Remote Sense compensates voltage drop on the load wiring up to 0.5V

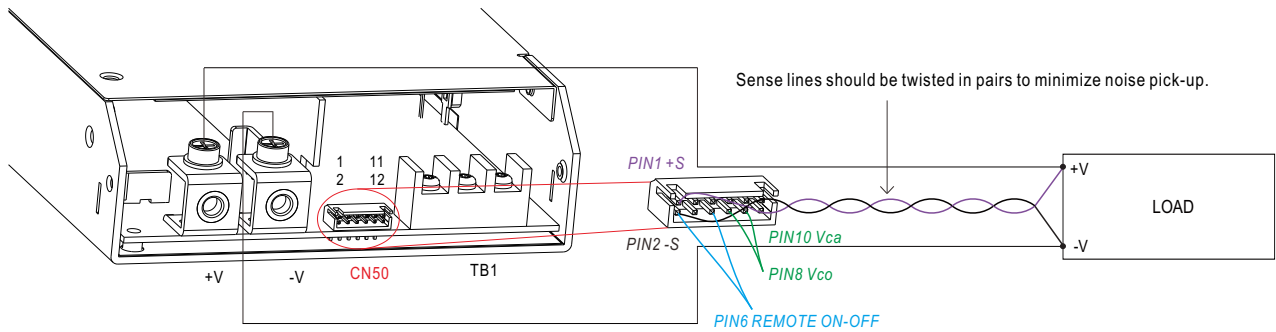

- ⊙ The +S signal should be connected to the positive terminal of the load whereas -S signal to the negative terminal.
- ⊙ This configuration is based on the assumption the Output Voltage Programming is not activated and power supply is ON.

Fig 1.1

2. Remote ON-OFF Control

※ The power supply can be turned ON-OFF individually or along with other units by using the "Remote ON-OFF" function.

Between Remote ON-OFF (pin6) and -S(pin2)	Power Supply Status
Switch Short	ON
Switch Open	OFF

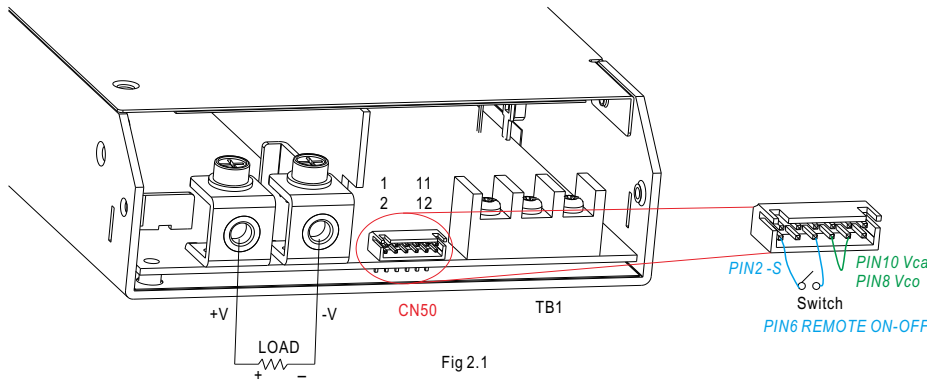

Fig 2.1

- ⊙ The power supply is shipped, by factory default, with Remote ON-OFF(pin6) and -S(pin2) shorted by connector.
- ⊙ When multiple power supplies need to turn ON/OFF simultaneously by Remote ON-OFF control, -S & -V, as well as +S & +V, on each power supply should be connected.

3. DC_OK signal

※ "DC_OK" is an open collector signal. It indicates the output status of the power supply. It can operate in two ways : One is sinking current from external TTL signal ; the other is sending out a TTL voltage signal.

- ⊙ **Sinking current from external TTL signal:** The maximum sink current is 10mA and the maximum external voltage is 5.6V.
- ⊙ **Sending out TTL voltage signal :**

Between DC- OK(pin5) and GND(pin11&12)	Output Status
0 ~ 1V	ON
3.3 ~ 5.6V	OFF

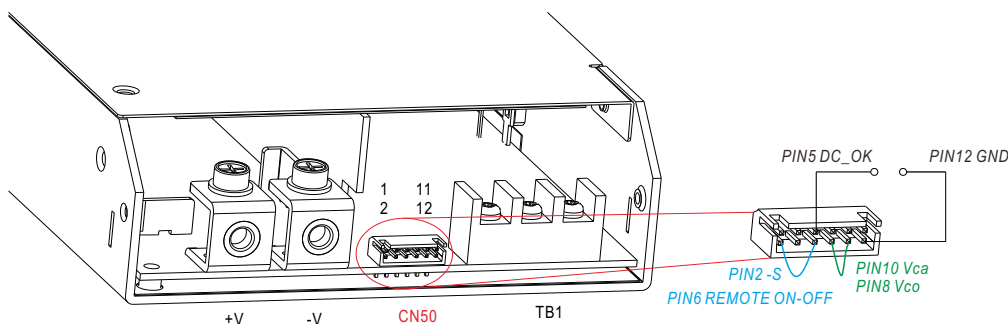
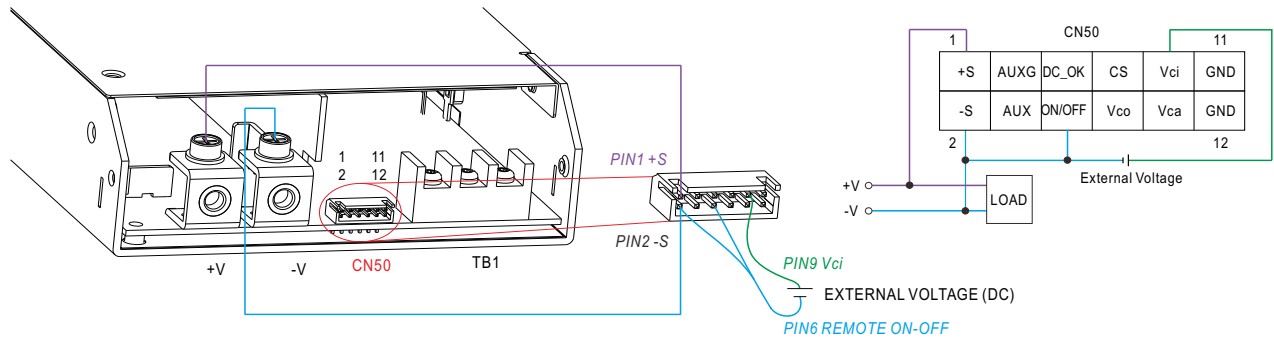

Fig 3.1

4. Output Voltage Programming (or, PV / remote voltage programming / remote adjust / margin programming / dynamic voltage trim)

※ In addition to the adjustment via the built-in potentiometer, the output voltage can be trimmed to 40~110% of the nominal voltage by applying either an EXTERNAL VOLTAGE or an EXTERNAL RESISTANCE.

(1)Applying EXTERNAL VOLTAGE between "Vci"(pin9) and "-S"(pin2) as shown in Fig4.1



◎ +S & +V and -S & -V also need to be connected on CN50

Fig 4.1

(2)Applying EXTERANL RESISTANCE as shown in Fig4.2 & Fig 4.3

(A) Output voltage goes down

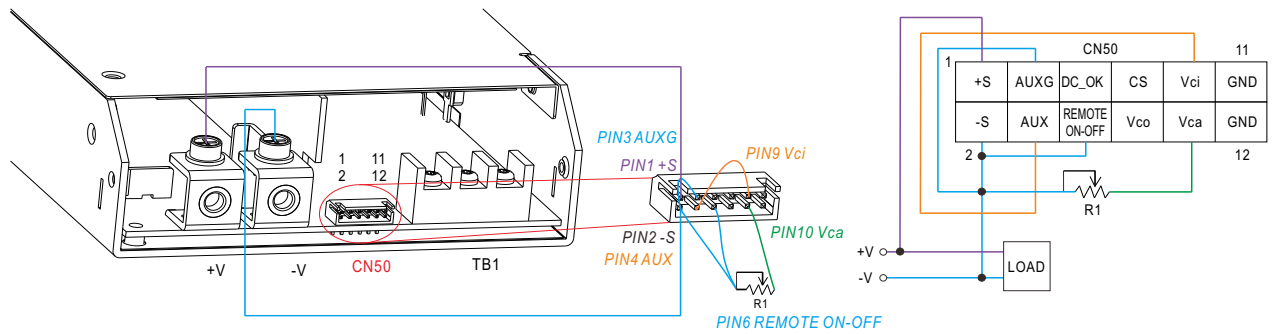

◎ +S & +V and -S & -V also need to be connected on CN50.

Fig 4.2

(B)Output voltage goes up

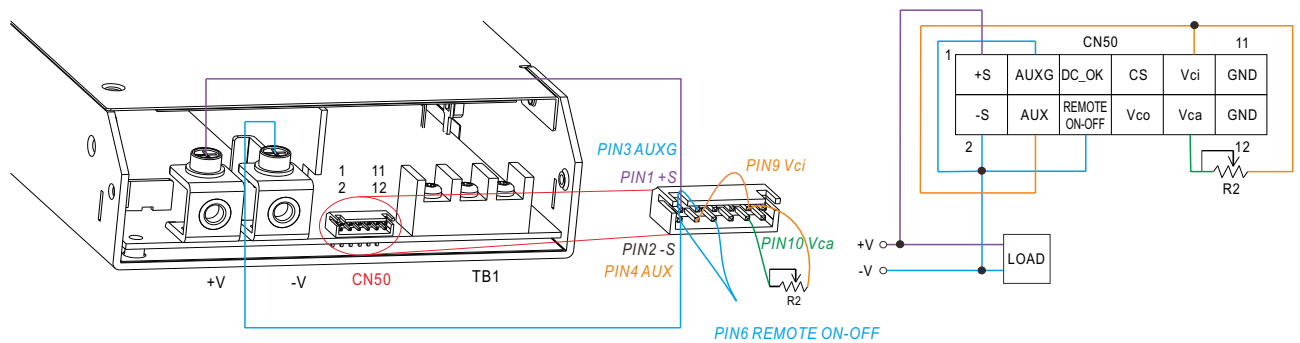

◎ +S & +V and -S & -V also need to be connected on CN50.

Fig 4.3

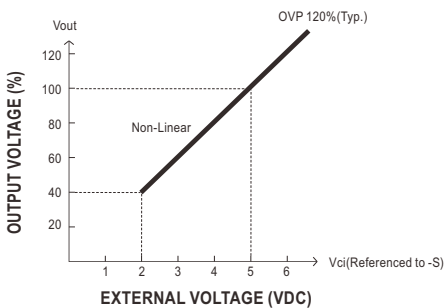

Fig 4.1.1

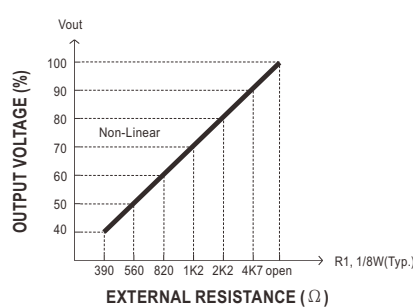

Fig 4.2.1

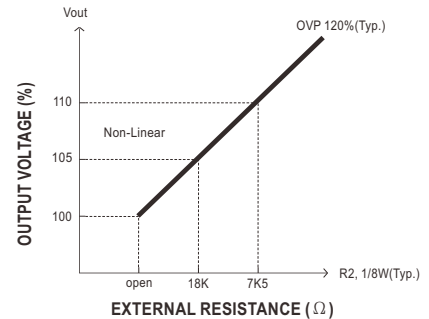

Fig 4.3.1

※ Caution: By factory default, the Output Voltage Programming is not activated, and Vco (pin8) and Vca(pin10) are shorted by connector. Whenever this function is not needed to activate, as assumed in other sections' diagrams, please keep Vco(pin8) and Vca(pin10) shorted ; other wise, the power supply will have no output.

5. Current Sharing with Remote Sense

RSP-1000 has the built-in active current sharing function and can be connected in parallel, up to 4 units, to provide higher output power as exhibited below :

- ※ The power supplies should be paralleled using short and large diameter wiring and then connected to the load.
- ※ Difference of output voltages among parallel units should be less than 0.2V.
- ※ The total output current must not exceed the value determined by the following equation:

$$\text{Maximum output current at parallel operation} = (\text{Rated current per unit}) \times (\text{Number of unit}) \times 0.9$$
- ※ When the total output current is less than 5% of the total rated current, or say $(5\% \text{ of Rated current per unit}) \times (\text{Number of unit})$ the current shared among units may not be fully balanced.

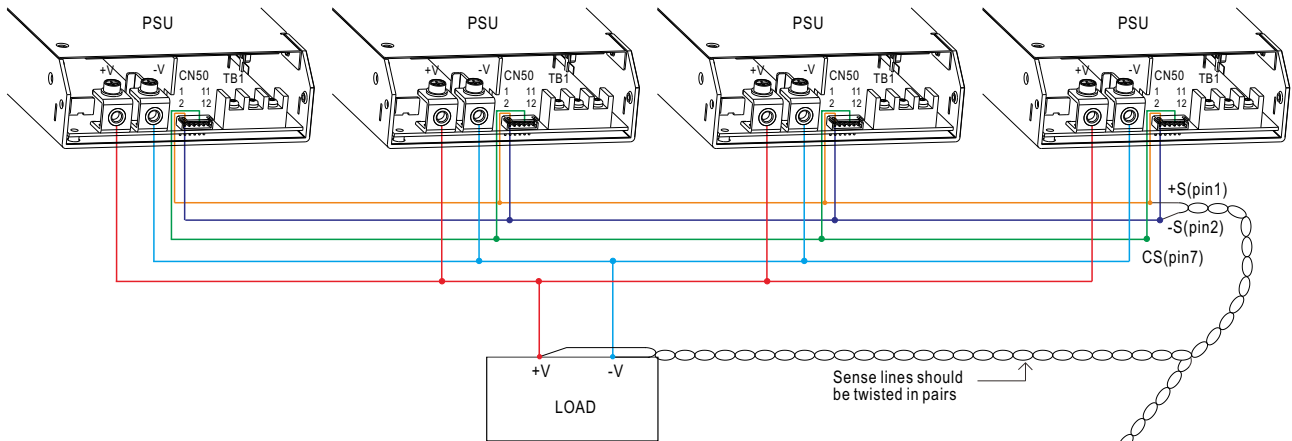
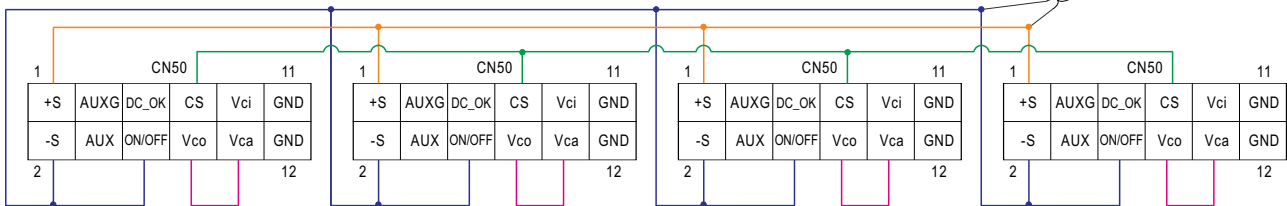

Fig 5.1



◎ +S, -S and CS are connected mutually in parallel.

■ Mechanical Specification

Case No. 952B Unit:mm

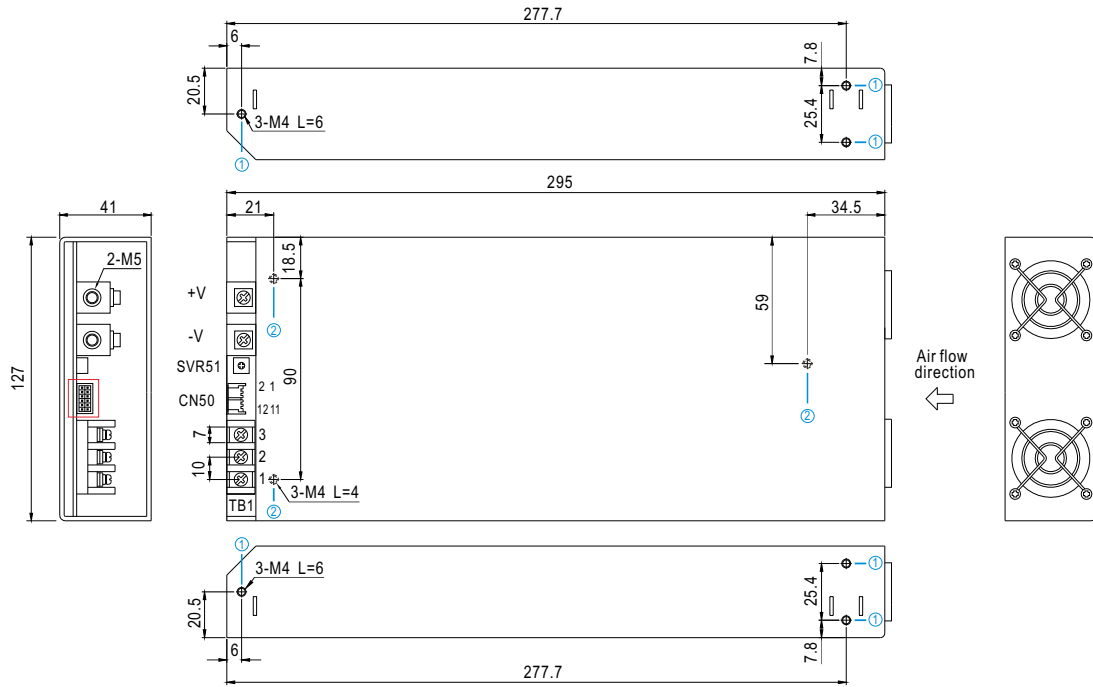

※ Mounting Instruction

Hole No.	Recommended Screw Size	MAX. Penetration Depth L	Recommended mounting torque
①	M4	6mm	7~11Kgf-cm
②	M4	4mm	7~11Kgf-cm

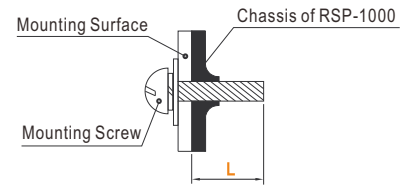

※Control Pin No. Assignment (CN50) : HRS DF11-12DP-2DS or equivalent

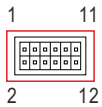

Mating Housing	HRS DF11-12DS or equivalent
Terminal	HRS DF11-12SC or equivalent

Pin No.	Function	Description
1	+S	Positive sensing for remote sense.
2	-S	Negative sensing for remote sense.
3	G-AUX	Auxiliary voltage output ground. The signal return is isolated from the output terminals (+V & -V).
4	5V-AUX	Auxiliary voltage output, 4.6~5.25V, referenced to pin 3(G-AUX). The maximum load current is 0.5A. This output has the built-in oring diodes and is not controlled by the "remote ON/OFF control".
5	DC_OK	Open collector signal, referenced to pin11,12(GND). Low when PSU turns on. The maximum sink current is 10mA and the maximum external voltage is 5.6V.
6	Remote ON-OFF	Turns the output on and off by electrical or dry contact between pin 6 (Remote ON-OFF) and pin 2 (-S). Short: Power ON, Open: Power OFF.
7	CS	Current sharing signal. When units are connected in parallel, the CS pins of the units should be connected to allow current balance between units.
8	Vco	Short connecting between Vco (pin8) and Vca (pin10) if output voltage programming function is not activated.
9	Vci	Connect to external DC voltage source for output voltage programming, referenced to pin 2 (-S).
10	Vca	Connect to external resistor (1/8W) for output voltage programming.
11,12	GND	These pins connect to the negative terminal (-V). Return for DC_OK Signal output.

※AC Input Terminal Pin No. Assignment

Pin No.	Assignment	Diagram	Maximum mounting torque
1	AC/N		18Kgf-cm
2	AC/L		
3	FG \perp		

※DC Output Terminal Pin No. Assignment

Assignment	Diagram	Maximum mounting torque
+V, -V		10Kgf-cm

■ Installation Manual

Please refer to : <http://www.meanwell.com/manual.html>