

Evaluation Board Data Sheet for the CS8415A

Features

- CS8415A Digital Audio Receiver
- CS8405A Digital Audio Transmitter
- Receives and transmits AES/EBU, S/PDIF and EIAJ-340 compatible digital audio
- Analog 5 Volt supply.
- Digital 5 Volt or 3 Volt supply
- Crystal supplied to allow transmitter to operate at 48 kHz sample rate
- Digital patch area

Description

The CDB8415A is designed to allow easy evaluation of the CS8415A and CS8405A. The board is set up for easy connection to an Audio Precision or a Rohde and Schwarz test system.

Input and output data may independently be set to either AES/EBU or S/PDIF in optical or coaxial physical formats.

Windows 98 PC software provides a GUI interface to make configuration easy. The software communicates through the PC's Parallel port to control the internal registers so that all the possible software modes of the CS8415A and CS8405A may be tested.

ORDERING INFORMATION

CDB8415A

Evaluation Board

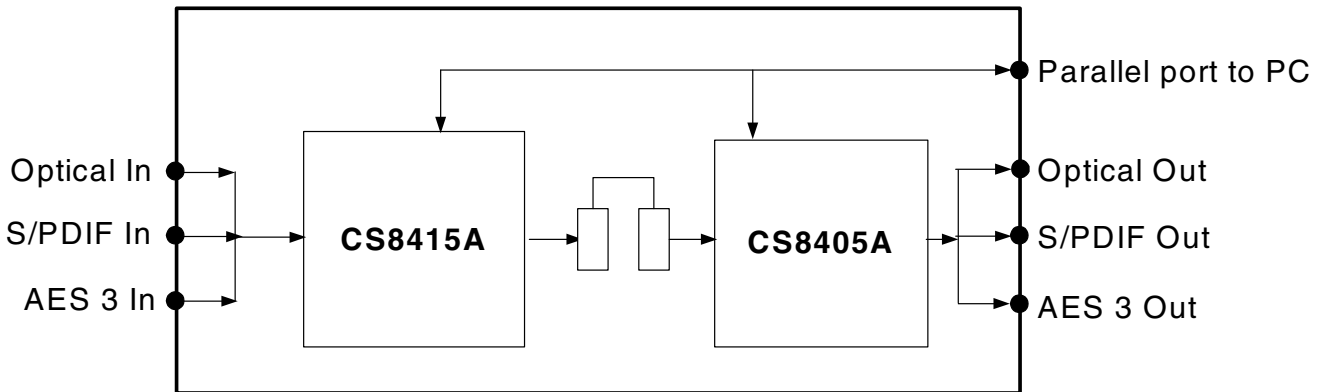

Preliminary Product Information

This document contains information for a new product. Cirrus Logic reserves the right to modify this product without notice.

TABLE OF CONTENTS

1. OVERVIEW	3
1.1 CS8415A an CS8405A	3
1.2 Parallel Port	3
1.3 Serial Digital Inputs	3
1.4 Serial Digital Outputs	3
1.5 Three Wire Serial Input and Output	3
1.6 Micro-Controller Serial Ports	3
1.7 Crystal Oscillators	3
1.8 LED Function Indicators	3
2. CDB8415A.EXE QUICK START GUIDE	5
2.1 Setting up the hardware:	5
2.2 Installing the software:	5
2.3 Starting up the software:	5
2.4 Starting up the Hardware:	5
3. CDB8415A.EXE USER'S GUIDE	6
3.1 Main Window	6

LIST OF FIGURES

Figure 1. CDB8415A Main Control Panel.....	6
Figure 2. CDB8415A Control Panel	7
Figure 3. CDB8405A Control Panel	7
Figure 4. Advanced Control Panel	8
Figure 5. Parallel Port.....	9
Figure 6. Power Supplies	10
Figure 7. 8415A Receiver.....	11
Figure 8. CS8405A Transmitter.....	12
Figure 9. Silkscreen.....	13
Figure 10. Top PCB.....	14
Figure 11. Bottom PCB	15

Contacting Cirrus Logic Support

For a complete listing of Direct Sales, Distributor, and Sales Representative contacts, visit the Cirrus Logic web site at:
<http://www.cirrus.com/corporate/contacts/sales.cfm>

IMPORTANT NOTICE

"Preliminary" product information describes products that are in production, but for which full characterization data is not yet available. "Advance" product information describes products that are in development and subject to development changes. Cirrus Logic, Inc. and its subsidiaries ("Cirrus") believe that the information contained in this document is accurate and reliable. However, the information is subject to change without notice and is provided "AS IS" without warranty of any kind (express or implied). Customers are advised to obtain the latest version of relevant information to verify, before placing orders, that information being relied on is current and complete. All products are sold subject to the terms and conditions of sale supplied at the time of order acknowledgment, including those pertaining to warranty, patent infringement, and limitation of liability. No responsibility is assumed by Cirrus for the use of this information, including use of this information as the basis for manufacture or sale of any items, or for infringement of patents or other rights of third parties. This document is the property of Cirrus and by furnishing this information, Cirrus grants no license, express or implied under any patents, mask work rights, copyrights, trademarks, trade secrets or other intellectual property rights. Cirrus owns the copyrights of the information contained herein and gives consent for copies to be made of the information only for use within your organization with respect to Cirrus integrated circuits or other parts of Cirrus. This consent does not extend to other copying such as copying for general distribution, advertising or promotional purposes, or for creating any work for resale.

An export permit needs to be obtained from the competent authorities of the Japanese Government if any of the products or technologies described in this material and controlled under the "Foreign Exchange and Foreign Trade Law" is to be exported or taken out of Japan. An export license and/or quota needs to be obtained from the competent authorities of the Chinese Government if any of the products or technologies described in this material is subject to the PRC Foreign Trade Law and is to be exported or taken out of the PRC.

CERTAIN APPLICATIONS USING SEMICONDUCTOR PRODUCTS MAY INVOLVE POTENTIAL RISKS OF DEATH, PERSONAL INJURY, OR SEVERE PROPERTY OR ENVIRONMENTAL DAMAGE ("CRITICAL APPLICATIONS"). CIRRUS PRODUCTS ARE NOT DESIGNED, AUTHORIZED, OR WARRANTED TO BE SUITABLE FOR USE IN LIFE-SUPPORT DEVICES OR SYSTEMS OR OTHER CRITICAL APPLICATIONS. INCLUSION OF CIRRUS PRODUCTS IN SUCH APPLICATIONS IS UNDERSTOOD TO BE FULLY AT THE CUSTOMER'S RISK.

Cirrus Logic, Cirrus, and the Cirrus Logic logo designs are trademarks of Cirrus Logic, Inc. All other brand and product names in this document may be trademarks or service marks of their respective owners.

1. OVERVIEW

The CDB8415A evaluation board contains a CS8415A and a CS8405A and the supporting circuitry necessary for them to operate. The input and output options include AES3 and S/PDIF in optical and coaxial formats. In software mode, the control registers of the CS8415A and CS8405A are set through the parallel port of a PC by a Windows 98 based program to control the configuration.

1.1 CS8415A and CS8405A

The features and functions of the CS8415A and the CS8405A are described in their data sheets.

1.2 Parallel Port

To use the CS8415A and CS8405A on the board in software mode, the parallel port on the upper right hand side of the board should be connected to the parallel port of the PC running the CDB8415A control software. In software mode remember to enable the clocks in both parts from the configuration software.

1.3 Serial Digital Inputs

The left hand end of the board is occupied by a row of serial digital audio input connectors. In hardware mode, the user may select from the optical connector, the XLR connector, or the first RCA jack. Only one of these inputs should be connected at a time. In software mode the user has access to these inputs and to the S/PDIF multiplexer. In the multiplexer mode jack J17, labeled OPT, should be jumpered in the enable position. The user can provide inputs to any or all of the seven RCA input jacks. The active input is selected by setting the three least significant bits of Control Register 2. **Please note that the current version of the board has a layout error. Jacks 6 and 7 are reversed.**

1.4 Serial Digital Outputs

On the upper right hand side of the board are the three serial digital audio outputs. The Optical S/PDIF output is always enabled. The user may

also choose to enable either the coaxial S/PDIF output or the XLR AES3 output.

1.5 Three Wire Serial Input and Output

Jacks J32 and J51 are provided so the user may access the three wire serial ports of the receiver and transmitter. The purpose of these ports is to allow the user to connect his external circuitry to the receiver and transmitter. A flat jumper cable is also provided to allow the output of the receiver to drive the input of the transmitter. This allows the user to operate the board in transceiver mode.

1.6 Micro-Controller Serial Ports

Headers J6 and J37 provide access to the serial control ports of the CS8415A and the CS8405A. Each jack has four serial control lines, a reset line, and an interrupt line. This allows the user to connect an external MCU of his choice to carry out testing and software development. These ports are in the same format as the header on the CDB8420 or the CDB8427. These two boards use an Atmel AVR microcontroller that can be patched in to communicate with the parts on this board. Another alternative is to patch in the development board of the MCU of your choice.

1.7 Crystal Oscillators

Oscillator U7 provides the Output Master Clock for the CS8405A. The crystal oscillator on the board is mounted in pin sockets that allow it to be removed or replaced. The board is shipped with a 12.288 MHz crystal oscillator stuffed at U7 which sets the output sampling rate to 48 kHz.

1.8 LED Function Indicators

LEDs D3 and D4 on the middle left hand side of the board allow the user to monitor the receiver status. LED D4 is connected to the RERR pin of the CS8415A and LED3 is connected to NVERR. See the CS8415A data sheet for an explanation of the errors that activate each of these outputs.

CONNECTOR	INPUT/OUTPUT	SIGNAL PRESENT
+5V	Input	+5 Volt Analog power
+3.3V-5V	Input	+3.3 to 5.0 Volt Digital power
GND	Input	Ground connection from power supply
OPTICAL INPUT	Input	Digital Audio Interface optical input
S/PDIF INPUT	Input	Digital Audio Interface coaxial input
AES3 INPUT	Input	Digital Audio Interface XLR input
PARALLEL PORT	Input/Output	Parallel port for connection to parallel port of PC
OPTICAL OUTPUT	Output	Digital Audio Interface optical output (always active)
S/PDIF OUTPUT	Output	Digital Audio Interface coaxial output
AES3 OUTPUT	Output	Digital Audio Interface XLR output
J32	Input/Output	I/O for RMCLK, ISCLK,ILRCK, and SDIN
J51	Input/Output	I/O for OLRCK, OSCLK, OMCK, and SDOUT
J6	Input/Output	12-pin header for CS8415A control from external μ C
J37	Input/Output	12-pin header for CS8405A control from external μ C

Table 1. System Connections

JUMPER	PURPOSE	POSITION	FUNCTION SELECTED
J7	Selects physical format of digital audio interface input	AES3 & S/PDIF OPTICAL	Specifies input as either AES3 or S/PDIF Specifies input as OPTICAL
J16	Enables AES3 INPUT	ENABLE DISABLE	AES3 INPUT enabled AES3 INPUT disabled
J18	Enables S/PDIF INPUT	ENABLE DISABLE	S/PDIF INPUT enabled S/PDIF INPUT disabled
J17	Enables OPTICAL INPUT	ENABLE DISABLE	OPTICAL INPUT enabled OPTICAL INPUT disabled
J46	Selects physical format of digital audio interface output	AES3 S/PDIF	Specifies output as AES3 XLR Specifies output as S/PDIF coaxial
J49	Enables S/PDFIF OUTPUT	ENABLE DISABLE	S/PDIF OUTPUT enabled S/PDIF OUTPUT disabled
J42	Choose HARDWARE/SOFTWARE	H S	Enables hardware mode Enables software mode

Table 2. CDB8415A Jumper Settings

2. CDB8415A.EXE QUICK START GUIDE

2.1 Setting up the hardware:

- 1) Check to make sure the flat three wire cable is connected from SDOUT, OLRCK, and OSCLK of J32 to SDIN, ILRCK, and ISCLK of J51.
- 1) Connect the Analog and Digital supplies of CDB8415A to a 5V DC power supply.
- 2) Set: J7 to OPT, and J17, OPT to Enable.
- 3) Set J55 to Receiver
- 4) Connect the CDB8415A to the PC parallel port using the parallel cable provided.
- 5) Apply power to the board.
- 6) Press the RESET switch (S5).

2.2 Installing the software:

- 1) Create a directory called CDB8415A anywhere on your system.
- 2) Copy CDB8415A.exe into this directory.
- 3) If you do not already have them, copy the included DLLs msvert.dll and mfc42.dll into your \Windows\System directory.

- 4) If desired, create a shortcut to CDB8415A.exe on your desktop.

At this point, you are ready to start up the software.

2.3 Starting up the software:

- 1) Double-click on CDB8415A.exe or its short-cut.
- 2) Click on the button on the lower right labeled Advanced.
- 3) Select the LPT port you are using to connect to the CDB8415.
- 4) Shut down the application, reset the board, and then restart the application.

2.4 Starting up the Hardware:

- 1) Click to enable the clocks for the CS8405A and click to enable the clocks for the CS8415A.
- 2) Click on the button: CS8415A Controls.
- 3) On the CS8415A control panel, check the box: Generate SCLK/LRCK.
- 4) Check the performance of the board by doing an FFT with a -1dBFS 1kHz sine wave for input at a 48kHz sample rate using the optical input and optical output.

3. CDB8415A.EXE USER'S GUIDE

3.1 Main Window

The CDB8415A Control Panel allows you to view the configuration of the CS8415A and the CS8405A. A limited set of controls are available for each part, including control of the enable clocks function (RUN bit in the Clock Control register) for each part. Clicking the left mouse button on either the CS8405A button or the CS8415A button will bring up a control panel containing all the register bits relevant to that part.

Clicking on the Advanced button at the lower right brings up the Advanced mode control panel. In Advanced mode you may read and write hex values into specified registers in either part. Changes made on the CS8405A or CS8415A control panels will also be immediately reflected in the Main Window, so you may wish to arrange them so that they do not obscure each other. Of particular use are the windows displaying the serial input formats of the two chips.

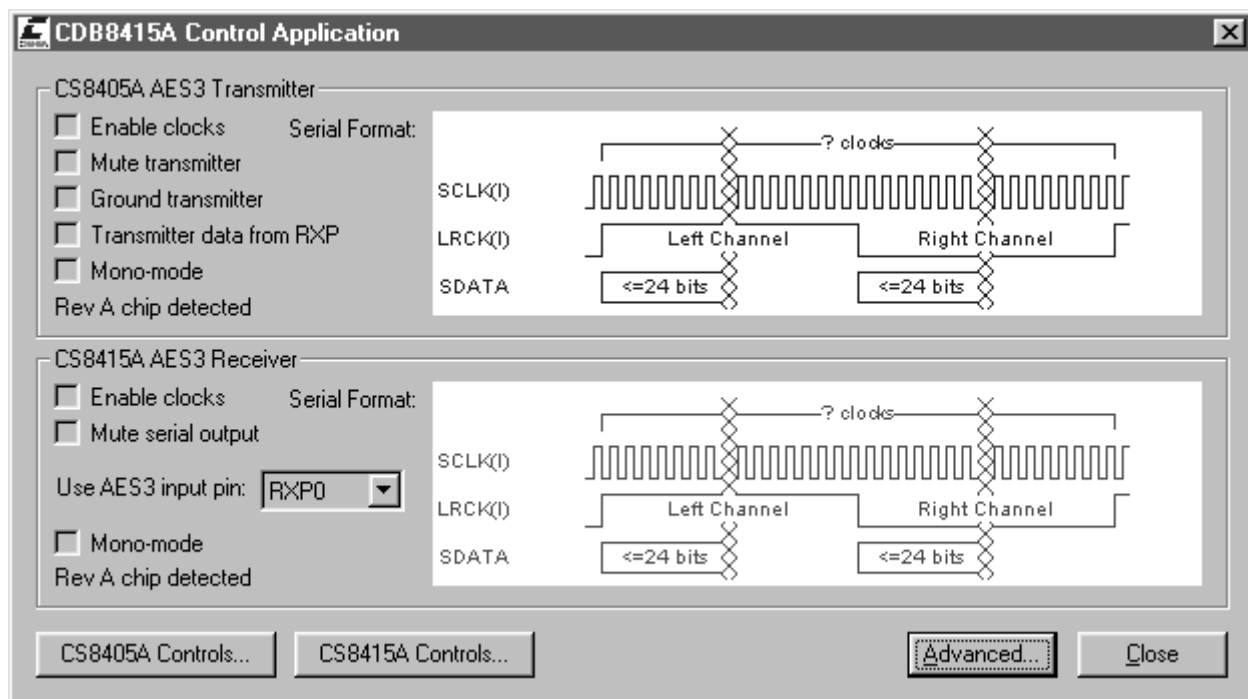

Figure 1. CDB8415A Main Control Panel

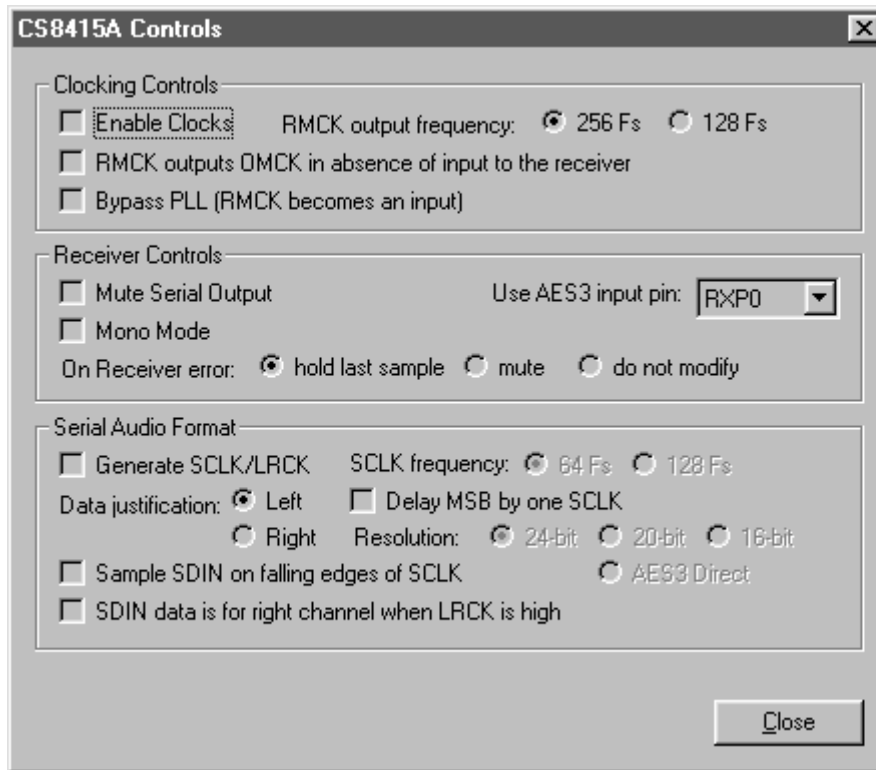

Figure 2. CDB8415A Control Panel

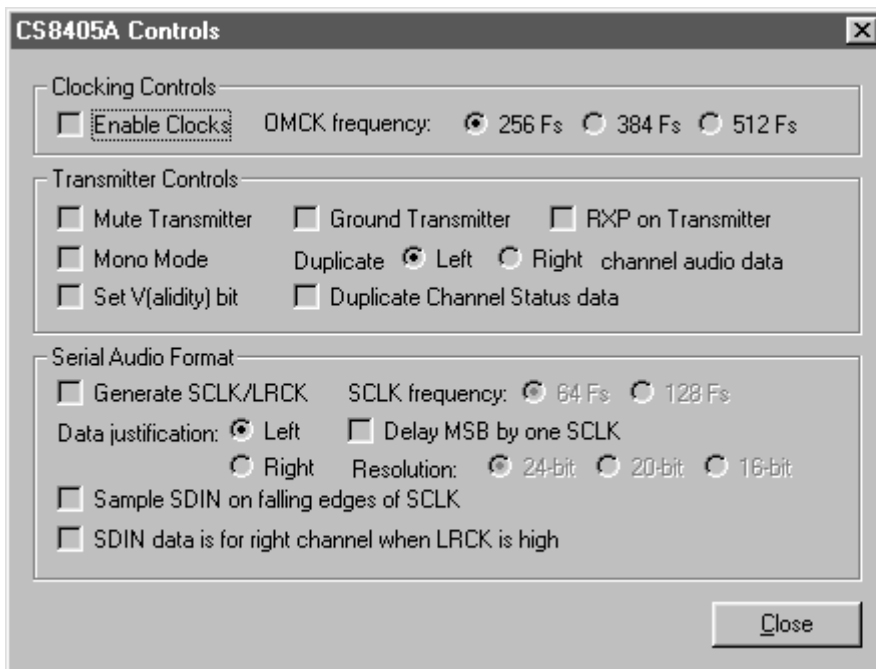

Figure 3. CDB8405A Control Panel

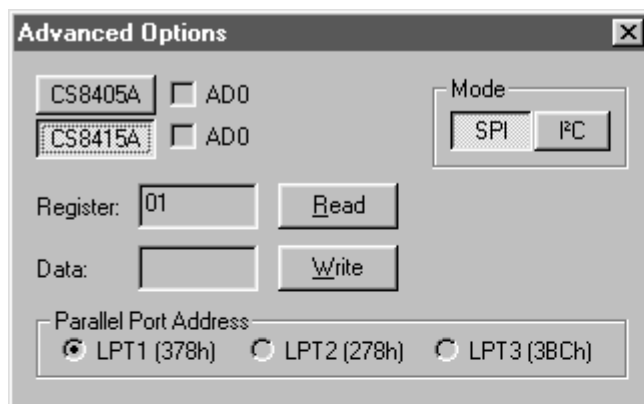
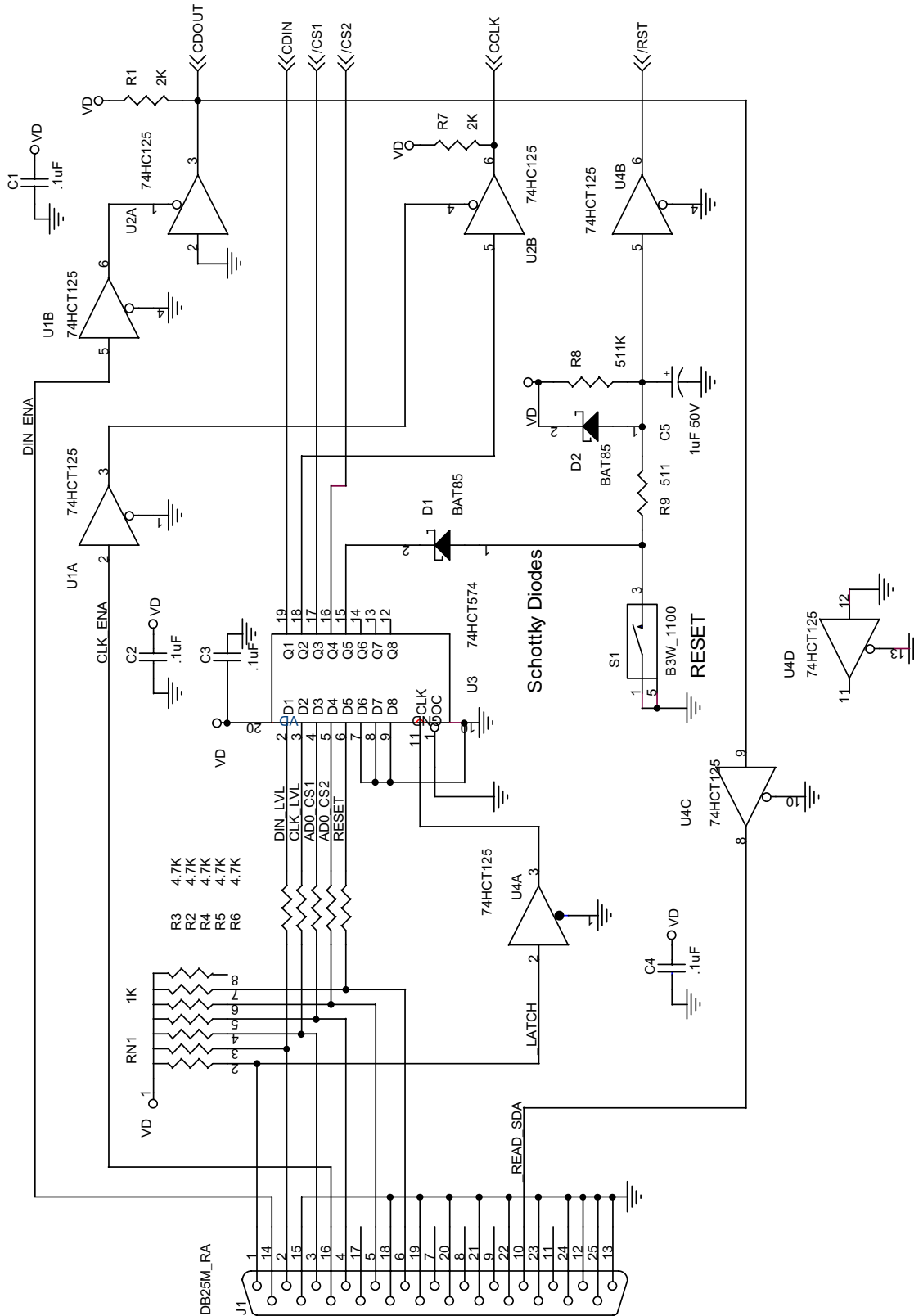
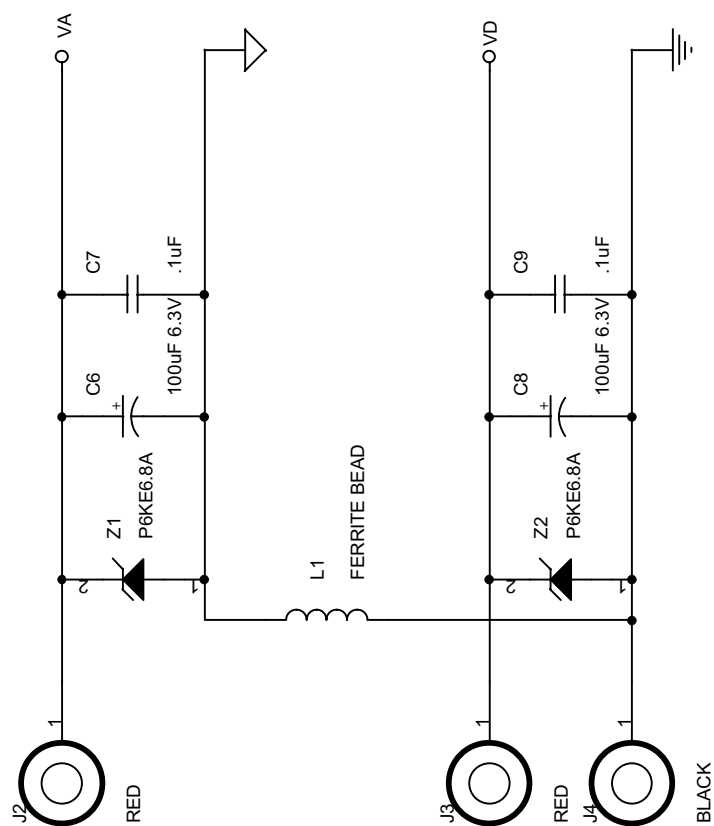
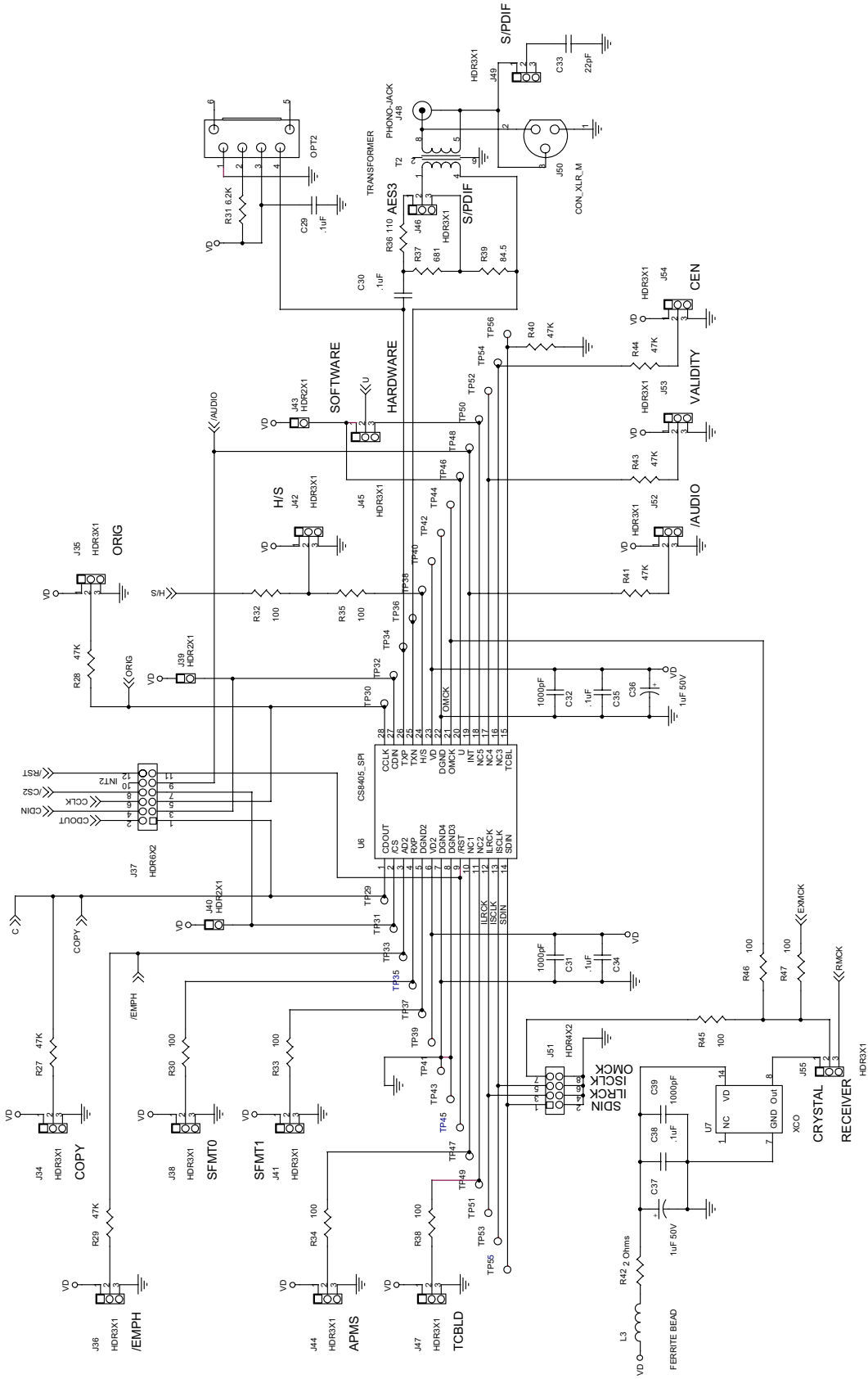

Figure 4. Advanced Control Panel

Figure 5. Parallel Port

Figure 6. Power Supplies

Figure 8. CS8405A Transmitter

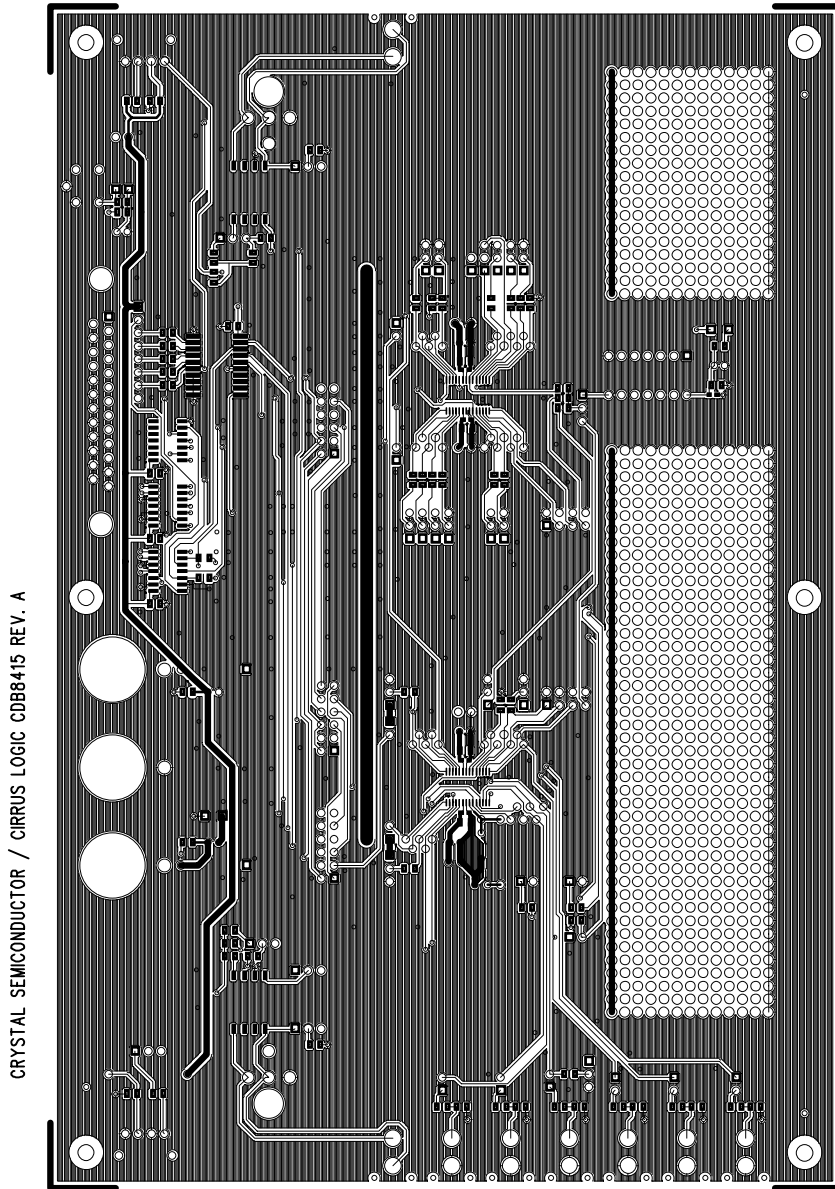

Figure 10. Top PCB

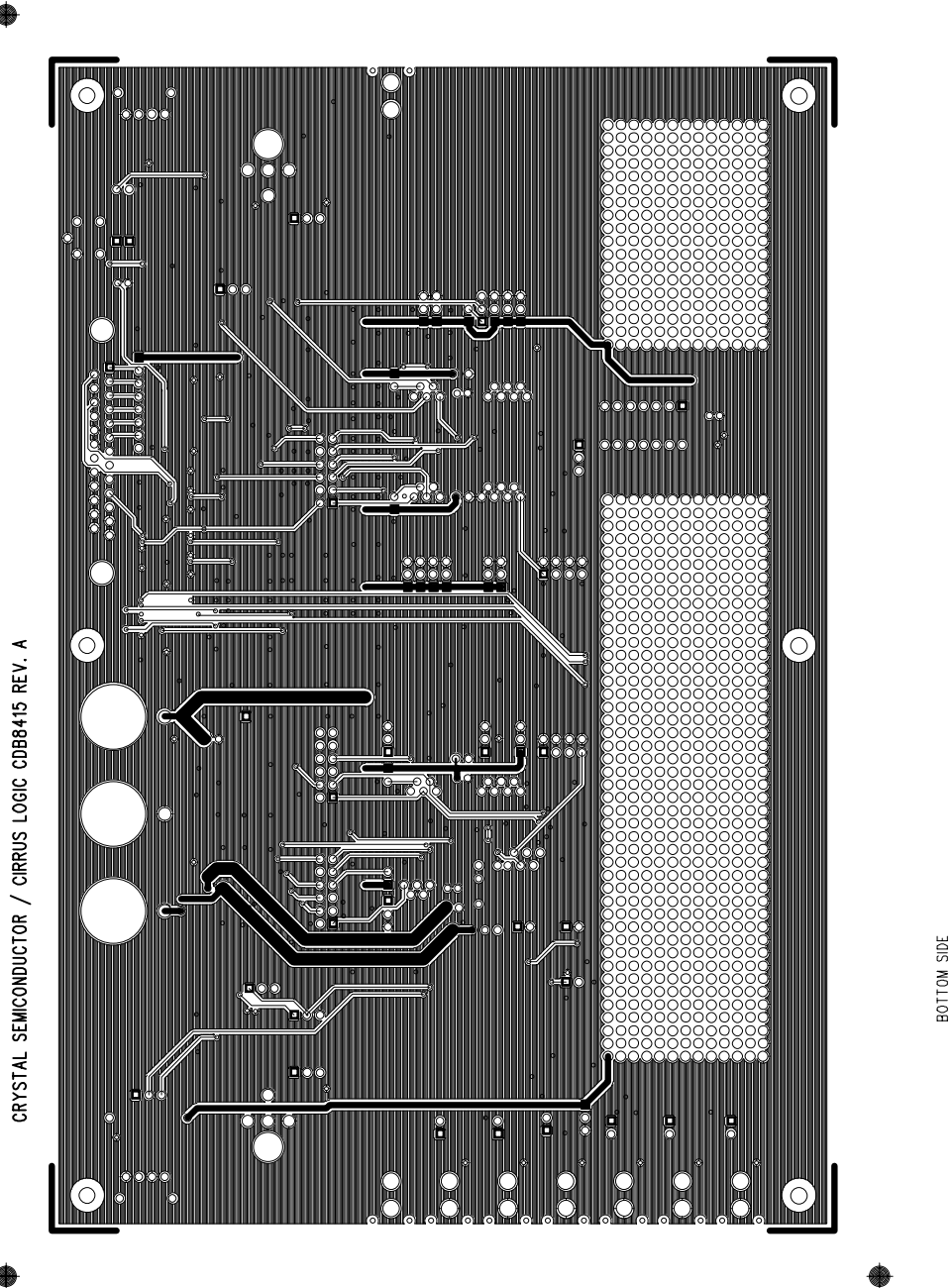

Figure 11. Bottom PCB



CIRRUS LOGIC[®]