



FEATURES

- 100W Full Bridge Topology
- Advanced Voltage mode Control with integrated Volt-Second Balance
- I2C serial interface to PC
- Software GUI
- Programmable digital filters
- 7 PWM outputs including Auxiliary PWM
- Digital Trimming
- OrFET Control for Hot swap and Redundancy
- Current, voltage, and temperature sense through GUI
- Calibration and trimming
- Analog/Digital current sharing

CAUTION

This evaluation board uses high voltages and currents. Extreme caution must be taken especially on the primary side, to ensure safety for the user. It is strongly advised to power down the evaluation board when not in use. A current limited power supply is recommended as input as no fuse is present on the board.

ADP1043A EVALUATION BOARD OVERVIEW

This evaluation board features the ADP1043A in a switching power supply application. With the evaluation board and software, the ADP1043A can be interfaced to any PC running Windows 2000/XP/Vista/NT via the computer's USB port. The software allows control and monitoring of the ADP1043A internal registers. The board is set up for the ADP1043A to act as an isolated switching power supply with a rated load of 12V/8A from an input voltage ranging from a 36 to 60VDC.

EVALUATION SYSTEM CONTENTS

The evaluation system package contains the following items:

- Application note EVAL-ADP1043AEB (order code: ADP1043AFB100EVALZ)
- ADP1043A evaluation board

The USB/I2C dongle for serial communication and software CD need to be ordered separately.
Order code: ADP1043A-USB-Z.

Rev. 1.3

Reference designs are as supplied "as is" and without warranties of any kind, express, implied, or statutory including, but not limited to, any implied warranty of merchantability or fitness for a particular purpose. No license is granted by implication or otherwise under any patents or other intellectual property by application or use of reference designs. Information furnished by Analog Devices is believed to be accurate and reliable. However, no responsibility is assumed by Analog Devices for its use, nor for any infringements of patents or other rights of third parties that may result from its use. Analog Devices reserves the right to change devices or specifications at any time without notice. Trademarks and registered trademarks are the property of their respective owners. Reference designs are not authorized to be used in life support devices or systems.

TABLE OF CONTENTS

Features	1
CAUTION	1
TOPOLOGY AND circuit description	4
CONNECTORS	4
SETTING FILES AND EEPROM	6
BOARD EVALUATION	7
EQUIPMENT	7
SETUP	8
ADP1043A PROGRAMMING SOFTWARE	10
FLAGS SETTINGS CONFIGURATIONS	11
GENERAL SETTINGS AND SOFTSTART	13
PWM AND SR SETTINGS	16
CS1 OR INPUT CURRENT SETTING	17
CS2 OR OUTPUT CURRENT SETTING	20
LIGHT LOAD MODE	22
OUTPUT VOLTAGE SETTINGS	24
DIGITAL FILTER SETTINGS AND TRANSIENT ANALYSIS	26
ORFET SETTINGS	29
APPENDIX I – SCHEMATIC (MAIN BOARD)	31
APPENDIX II – SCHEMATIC (DAUGHTER CARD)	32
APPENDIX III – LAYOUT (MAIN BOARD)	33
APPENDIX IV – LAYOUT (DAUGHTER CARD)	36
APPENDIX V - TRANSFORMER SPECIFICATION	39
APPENDIX V - TRANSFORMER SPECIFICATION	39
APPENDIX VI - OUTPUT INDUCTOR SPECIFICATION	41
APPENDIX VII - THERMAL PERFORMANCE	42
APPENDIX VII - THERMAL PERFORMANCE	42
APPENDIX VIII – STEADY STATE WAVEFORMS	43
APPENDIX IX – EFFICIENCY and VOLTAGE REGULATION	47
APPENDIX X – BILL OF MATERIALS (MAIN BOARD)	49
APPENDIX XI – BILL OF MATERIALS (DAUGHTER CARD)	52
APPENDIX XII – REGISTER FILE (ADP1043AFB100_I_0710.43R)	53
APPENDIX XIII – BOARD FILE (ADP1043AFB100_I_0710.43b)	55
APPENDIX XIV – CS1 AND CS2 MEASUREMENT vs GUI READING	56
Notes	57

REVISION HISTORY

07/15/2010—Revision 1.0: SPM
07/29/2010—Revision 1.1: SPM with MS feedback.
08/03/2010—Revision 1.2: SPM with MS and NSD feedback.
08/20/2010—Revision 1.3: Revisions to rev 1.2

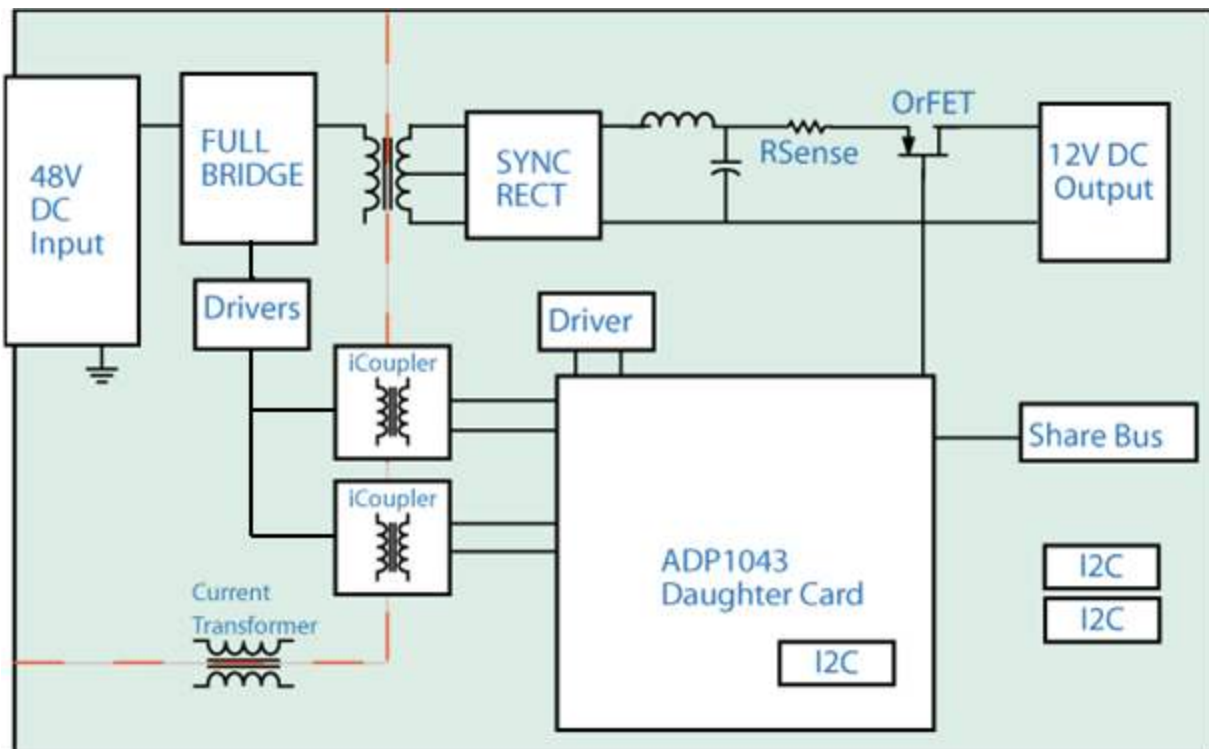

Figure 1 - Simplified Block Diagram

DEMO BOARD SPECIFICATIONS

Specification	MIN	TYP	MAX	Units	Notes
V _{IN}	36	48	60	V	
V _{OUT}		12		V	
I _{OUT}	0.0	8.0	10	A	
T _{AMBIENT}	0	30	65	°C	
Efficiency		87.25	89.4	%	Typical reading at 48V/8A load
Switching frequency	80	100.8	200	KHz	
Output Voltage Ripple			1.0	V	At 8A load

Table 1 - Target Specifications

TOPOLOGY AND CIRCUIT DESCRIPTION

This evaluation board features the ADP1043A in a typical DC/DC switching power supply in a full bridge topology with synchronous rectification. Figure 1 gives a block diagram of the main components on the board. The circuit is designed to provide a rated load of 12V/8A from an input voltage source of 36 to 60VDC. The ADP1043A provides functions such as the output voltage regulation, over current protection, load current sharing with multiple power supplies over the share bus, over temperature protection, and power supply shutdown.

Please refer to the appendix for the detailed schematic. The primary side consists of the input terminals, full bridge switches (QA to QD), the current sense transformer (T4) and the main transformer (T2). The ADP1043A (U1, on daughter card) resides on the secondary side and is powered via the USB 5V via an ADP3303 LDO (U2, on daughter card) present on the same daughter card. The gate signal for the primary switches comes from the ADP1043A through the iCouplers ADuM5230 (U14, U16) that provide isolation and power. The output of the iCoupler is connected to a buffer as it can source only 10mA of current. This buffer (network consisting of Q5 and Q6, Q7 and Q8, Q9 and Q10, Q11 and Q12) is used to drive the full bridge switches.

The secondary side power stage consists of the synchronous rectifiers (Q2 and Q3) and their respective drivers ADP3624 (U1), output inductor (L1), output capacitor (C4, C7), sense resistor (R17), and ORFET (Q1). Diode (D2) and capacitor (C6) form a peak detector that drives the ORFET. Capacitors (C23, C64, C67) provide high frequency decoupling to lower EMI.

Diodes (D15-D18) rectify the input current signal to sense the primary current and resistor (R10) converts the current into a voltage. The over current flag trips at 1.2V. Thermistor (RT1) is placed close to the ORFET on the board allowing over temperature protection functionality to be implemented.

Also present on the secondary is the current sharing circuitry, flag LEDs (D11-D12), communications port to the software through the I2C bus.

CONNECTORS

The connections to the evaluation board are shown below.

Connector	Evaluation Board Function
J3	48V DC Input
J2	Ground Return for 48V DC Input
J4	12V DC Voltage Output
J5	Ground Return for 12V DC Voltage Output
J8, J9	I2C Connector
J10	Share Bus
J1	Daughter card

Table 2 - Evaluation board connectors

There is a 4 pin connector for I2C communication. This allows the software to communicate with the evaluation board through the USB port of the PC. Instead of using an auxiliary supply, the board uses the 5V input from the USB port, and generates 3.3V using an LDO for the ADP1043A. The synchronous rectifier drivers (ADP3624) are also powered by the 5V USB, but are powered from the main 12V output after the output is in regulation.

Connectors (J8 and J9) are identical and are connected in parallel to each other to allow multiple boards to be connected to the same I2C bus in a daisy chain configuration. Each board consumes between 150mA and 250mA depending on the conditions. Particular care must be taken not to overload the USB 5V rail. Some USB ports are especially those connected at a hub may shut down if overloaded, causing communication problems. In such cases an external 5V power supply is recommended to power the board between test point TP44(+) and TP21(-).

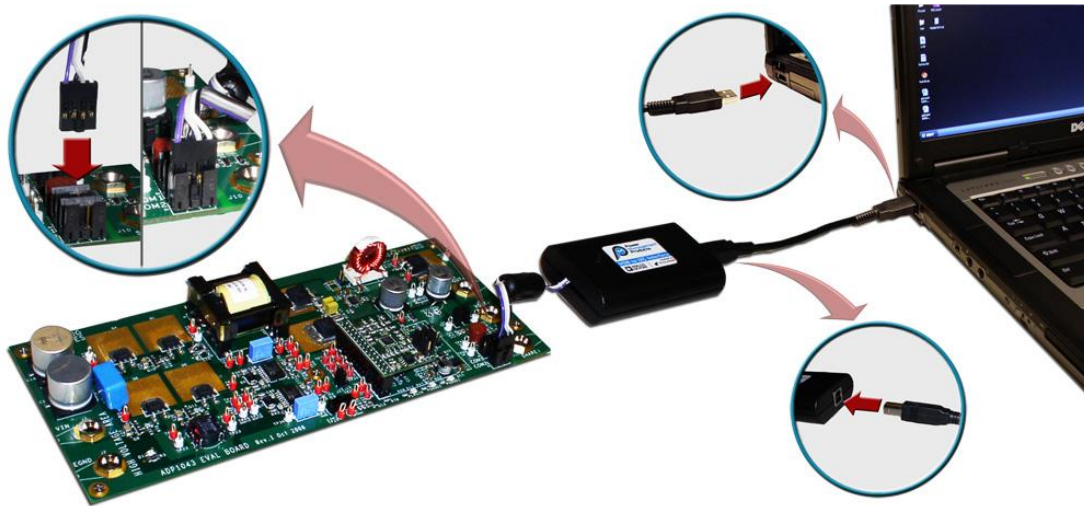

Figure 2 - Evaluation Board Setup

Pin	Evaluation Board Function
1	5V
2	SCL
3	SDA
4	Ground

Table 3 - J7, J8, J9 connections

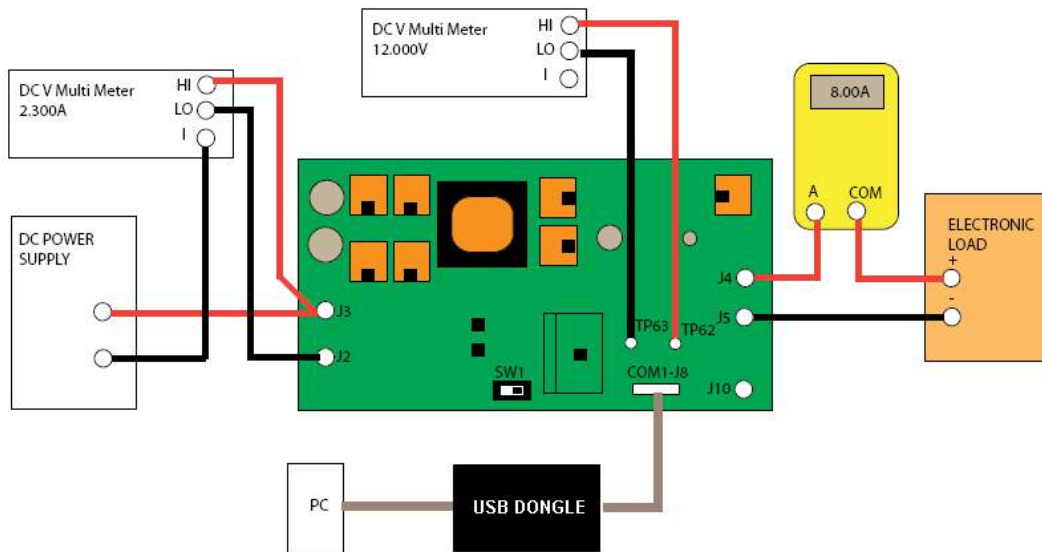

Figure 3 - Test configuration for the Evaluation Board

SETTING FILES AND EEPROM

The ADP1043A communicates with the GUI software using the I2C bus.

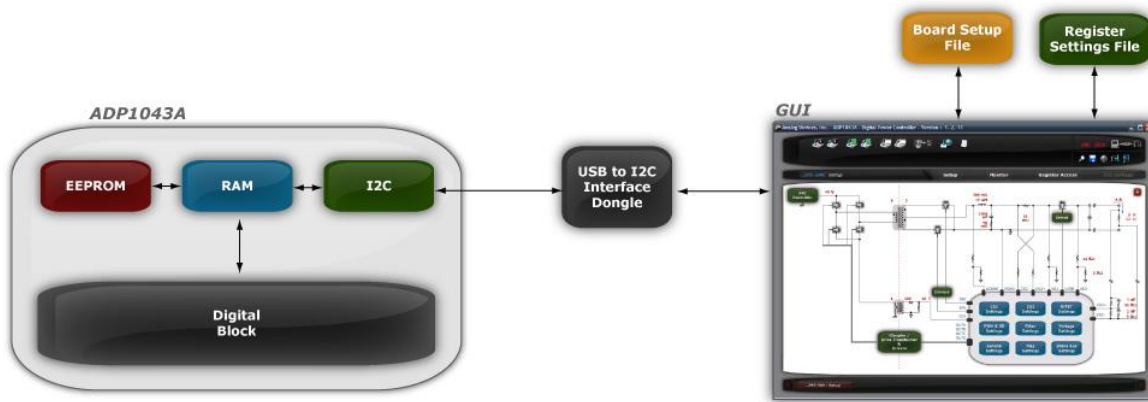

Figure 4 - ADP1043A and GUI interaction

The register settings (having extension .43r) and the board settings (having extension .43b) are two files that are associated with the ADP1043A software. The register settings file contains information that govern the functionality of the part such as the over voltage and over current limits, softstart timing, PWM settings etc. The ADP1043A stores all its settings in the EEPROM. When the ADP1043A is connected to the USB dongle the LDO powers the I.C. and the GUI downloads the settings from the registers of the ADP1043A so that the state of the part is known. It is possible to save these settings in a file for later use. Older register settings are overwritten when new files are loaded.

The EEPROM on the ADP1043A does not contain any information about the board, such as current sense resistor, output inductor and capacitor values. This information is stored in board setup file (extension .43b) and is necessary for the GUI to display the correct information in the 'Monitor' tab as well as 'Filter Settings' window. The ADP1043A does not need this information in order to operate, but the GUI will need it in order to show the values correctly in the 'Flags and Settings' window. The entire status of the power supply such as the ORFET and synchronous rectifiers enable/disable, primary current, output voltage and current can be thus digitally monitored and controlled using software only. Always make sure that the correct board file has been loaded for the board currently in use.

Each ADP1043A chip has trim registers for the temperature, input current and the output voltage and current. These can be configured during production and are not overwritten whenever a new register settings file is loaded. This is done in order to retain the trimming of all the ADCs for that corresponding environmental and circuit condition (component tolerances, thermal drift, etc.). A guided wizard called the 'Auto Trim' is started which trims the above mentioned quantities so that the measurement value matches the valued displayed in the GUI to allow ease of control through software.

In the following pages it will be shown that the ADP1043A can be easily programmed to modify the behavior of the PSU under different fault and load conditions without any hardware changes. All the changes are purely through software and do not require desoldering components and replacing them with new values to specify a different operating condition

BOARD EVALUATION

EQUIPMENT

- DC Power Supply
- Electronic Load
- Oscilloscope with differential probes
- PC with ADP1043A GUI installed
- Precision Digital Multimeters (HP34401 or equivalent - 6 digits) for measuring DC current and voltage

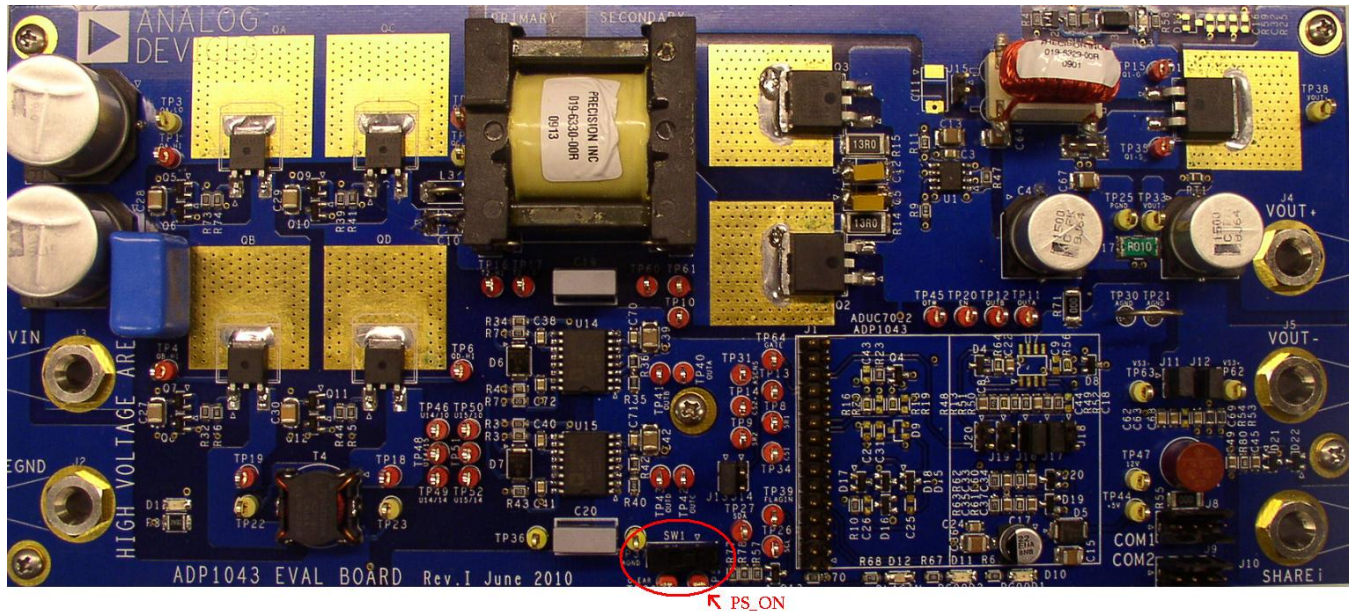

Figure 5 - 100W evaluation board showing PS_ON hardware switch



Figure 6 - ADP1043A daughter card

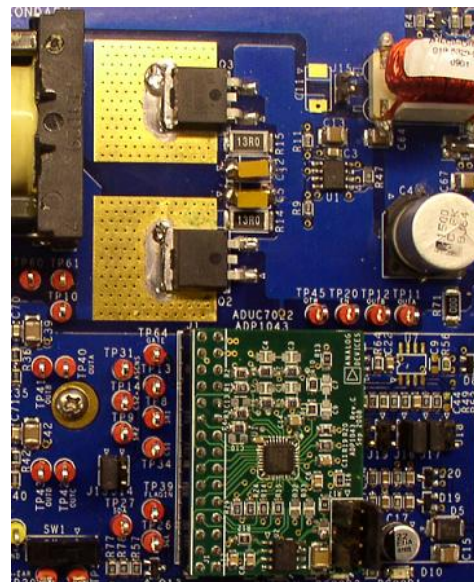

Figure 7 - Daughter card mounted on 100W board

SETUP

NOTE: DO NOT CONNECT THE USB CABLE TO THE EVALUATION BOARD UNTIL THE SOFTWARE HAS FINISHED INSTALLING

- 1) Install the ADP1043A software by inserting the installation CD. The software setup will start automatically and a guided process will install the software as well as the USB drivers for communication of the GUI with the IC using the USB dongle.
- 2) Insert the daughter card in connector J1 as shown in Figure 5.
- 3) Ensure that the PS_ON switch (SW1 on schematic) is turned to the OFF position. It is located on the bottom left half of the board (Figure 5).
- 4) Connect the evaluation board to the USB port on the PC using the “USB to I2C interface” dongle as shown in Figure 2.
- 5) The software should report that the ADP1043A has been located on the board. Click “Finish” to proceed to the Main Software Interface Window. The serial number reported on the side of the checkbox indicates the USB dongle serial number. The windows also displays the device I2C address.



Figure 8 - ADP1043A address in the GUI

5. If the software does not detect the part it enters into simulation mode. Ensure that the connector is connected to J8/J9 (on main board) or J7 (on daughter card). Click on 'Scan for ADP1043A now' icon (magnifying glass) located on the top right hand corner of the screen.



Figure 9 - "Scan for ADP1043A Now" icon

5. Click on the “Load Board Settings” icon (fourth button from the left) and select the ADP1043AFB100_I_0710.43b file. This file contains all the board information including values of shunt and voltage dividers. Note: All board setting files have an extension of .43b



Figure 10 - Different icons on dashboard for loading and saving .43r and .43b files

6. **The IC on the evaluation board comes preprogrammed and this step is optional.** The original register configuration is stored in the ADP1043AFB100_I_0710.43r register file. (I and 0710 stand for the hardware revision number and the month/year date code respectively). Note: All register files have an extension of .43r. The file can be loaded using the second icon from the left in Figure 10.
7. Connect a DC power source (48VDC nominal, current limit to 5A) and an electronic load at the output set to 8 Amperes.
8. Connect a voltmeter on the output (connectors J4 and J5) and a differential scope probes (optional) between test points TP16 and TP17. Ensure that the differential probes are used and the ground of the probes are isolated if measurements are made on the primary and secondary side of the transformer simultaneously).
9. Turn the PS_ON switch (SW1 on schematic) to the ON position.
10. The evaluation board should now up and running, and ready for evaluation. The output should now read 12 VDC.
11. Click on the 'MONITOR' tab and then on the Flags and readings icon. This windows provides a snapshot of the entire state of the PSU in a single user friendly window.

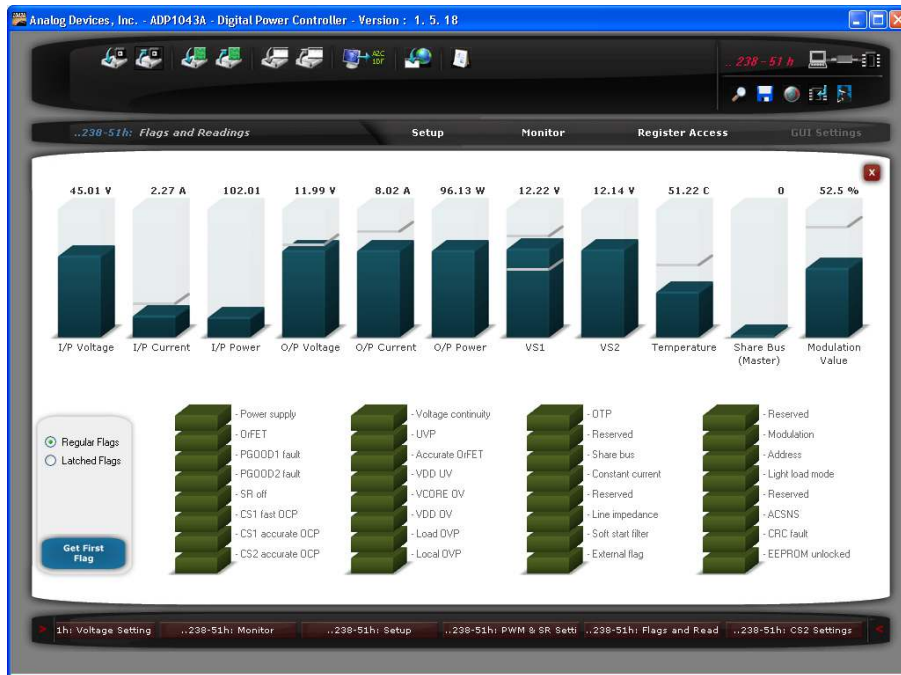

Figure 11 - Monitor window in GUI

During power up, the ADP1043A is connected to the USB port (5V) and the LDO powers the IC. It takes 20µsec for V_{CORE} (pin 26) to reach an internal voltage of 2.5V. After this, the I.C. downloads the contents of the registers into the EEPROM. After this the softstart ramp begins.

After successful startup and in steady state condition, 5 LEDs on the board to provide to the user the status of the board. All except the D12 (or FLAGIN) LED will be turned ON indicating that there are no faults detected such as over voltage or over current. In case of a fault the POOD1 or PGOOD2 LEDs will be turned OFF indicating that some flag has tripped due to an out of bounds condition. The monitor window will display the appropriate state of the PSU.

LED	Location	Description
D1 (Red)	Bottom left	Indicates input voltage is present
D10 (Yellow)	Bottom right	PGOOD1 signal (active low)
D11 (Red)	Bottom right	PGOOD2 signal (active low)
D12 (Red)	Bottom right	FLAGIN signal
D13 (Red)	Top right	Indicates ORFET is turned ON

Table 4 – List of LEDs on the evaluation board

ADP1043A PROGRAMMING SOFTWARE

The goal of this evaluation kit is to allow the user to get an insight into the flexibility offered by the extensive programming options offered by the ADP1043A. Several test points on the board allow easy monitoring of the various signals. The user can also use the software to program multiple responses (such as disable power supply or turn off ORFET) for various fault conditions.

The following sections give provide a good overview of the software as well as the test data experiments that the user might typically evaluate. There are 9 main windows (blue icons in figure below) where the user can use to program and evaluate the PSU. They can be accessed from the Setup window in the GUI.

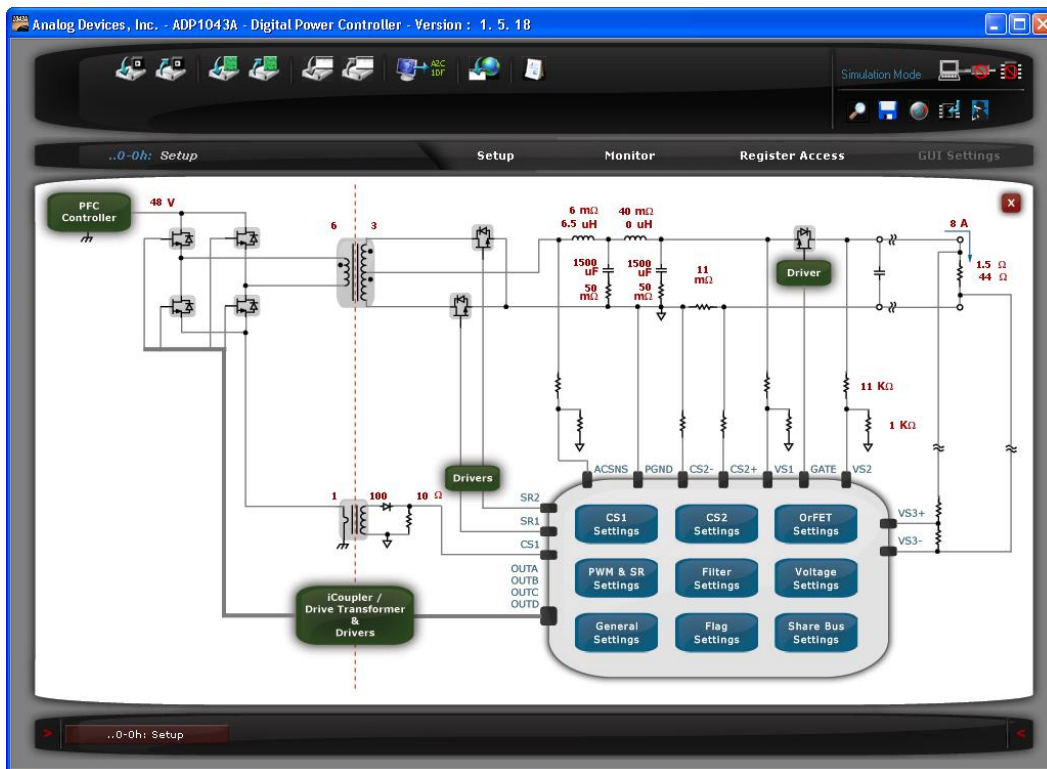

Figure 12 - Main Setup window of ADP1043A GUI

FLAGS SETTINGS CONFIGURATIONS

The following state machine diagram provides a graphical idea as to how the flags in the ADP1043A operate and hence gain insight into the working of the IC.

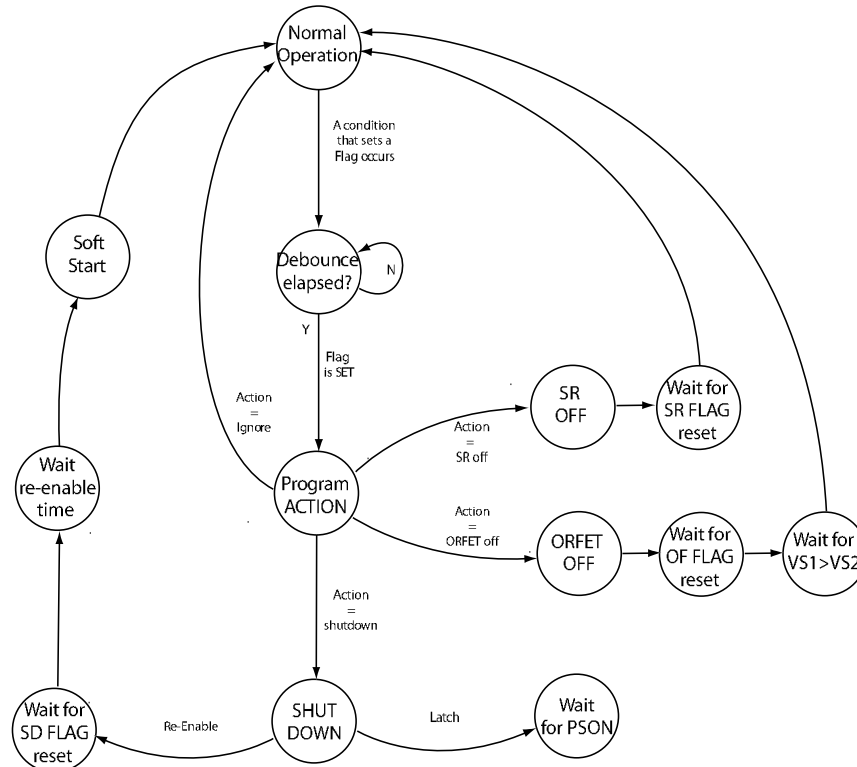

Figure 13 - State Machine diagram showing operating procedure

Basically when a flag is triggered, the controller waits for a programmable debounce time before taking any action. The response to each flag can be programmed individually. The flags can be programmed in a single window by hitting the FLAG SETTINGS icon in the MONITOR tab in the GUI and the state of the power supply can be monitored by clicking on the FLAGS AND READINGS icon in the MONITOR tab.

This monitor window shows all the fault flags (if any) and the readings in one page. The 'Get First Flag' button determines the first flag that was set in case of a fault event.

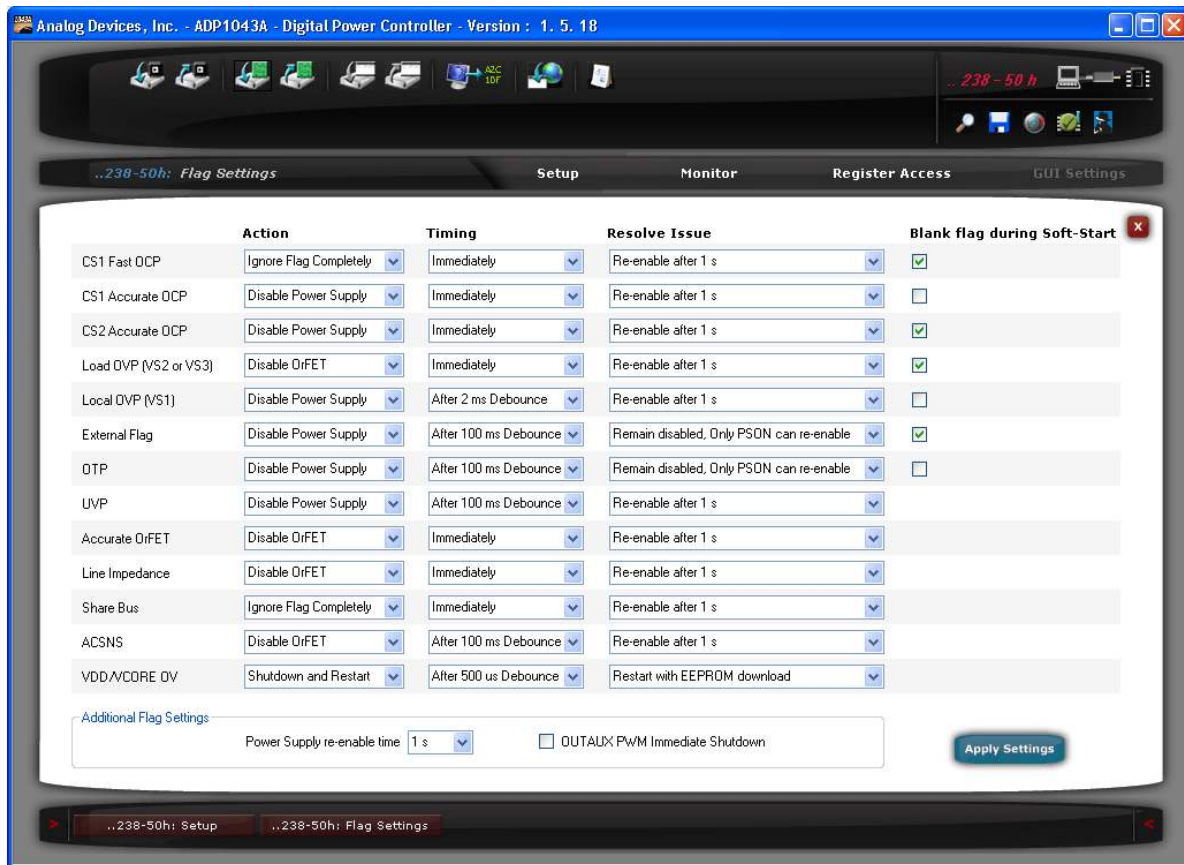

Figure 14 - Fault Configurations

The ADP1043A is programmed to respond to the various fault conditions in the Flag Settings Window.

ACTION: Ignore Flag Completely, Disable Synchronous Rectifiers, Disable ORFET, and Disable power Supply are the operations available in this column.

TIMING: This defines if an ACTION is taken immediately or after a debounce. Debounce is a term used for a wait period in digital circuitry. After a flag signal is detected, the debounce routine checks if the flag signal remains in its changed state for the entire programmed debounce period before taking any action. This prevents the ADP1043A from reacting to false positives.

RESOLVE ISSUE: This determines the operation of the PSU after the fault is cleared. Hysteretic or latching options are available.

GENERAL SETTINGS AND SOFTSTART

This section programs the PS_ON turn on and softstart timing. The power supply (PSU) can be turned on with a manual switch (hardware PS_ON), a software enabled switch (SW PS_ON), or both with a programmable delay. It contains the capability of adding a soft start to the primary and secondary switches (synchronous rectifiers) and also displays the temperature of the thermistor for the over temperature protection. It is not recommended to use the soft stop ramp as it overrides any protection features such as overcurrent protection.

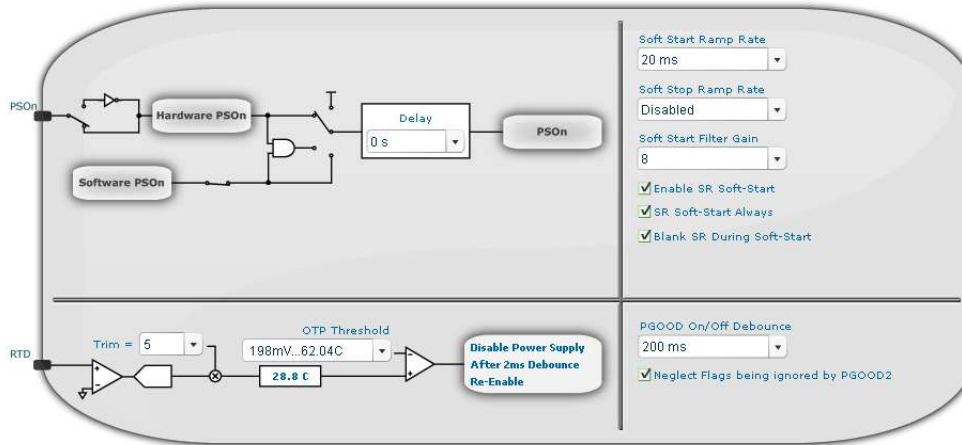

Figure 15 - General Settings window showing PS_ON, temperature flags, and softstart settings

Some test results are provided to better appreciate the flexibility of part. In addition to these some suggestions for further exploration are also provided.

- A. **PS_ON Turn on Delay:** Figure 16 and Figure 17 show the startup sequence with a 0.5 second and 2 second delay respectively. This test was conducted by monitoring the PSON signal (TP29), the output voltage (J4 and J5) and setting a programmable delay using the drop down menu. Monitoring the synchronous rectifier (test point SR1 and SR2) is optional.

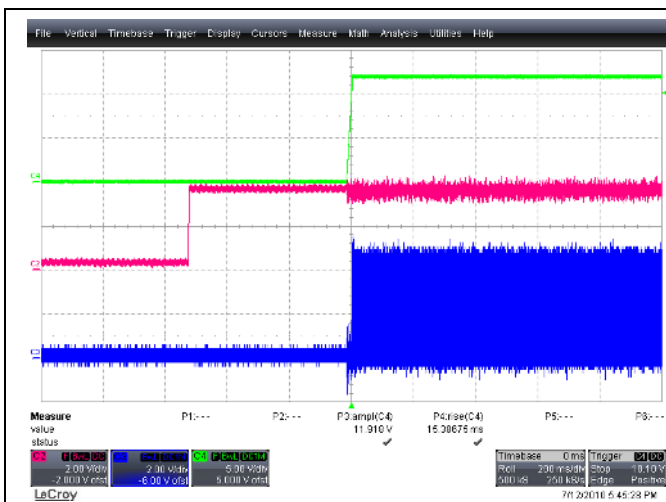

Figure 16 - Startup with 0.5sec delay, 48VDC, 8A load, with synchronous rectifiers disabled during softstart.
 Upper trace: Output voltage, 5V/div, 200ms/div
 Middle trace: PS_ON, 2V/div, 200ms/div
 Lower trace: Test point SR1, 2V/div, 200ms/div

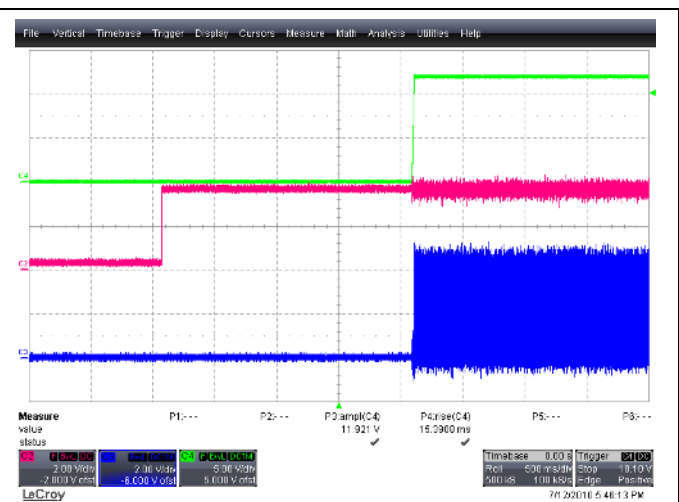
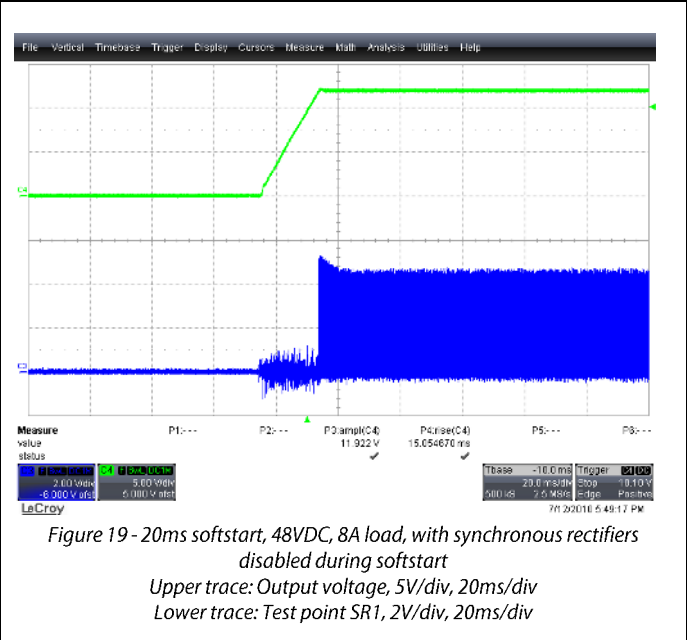
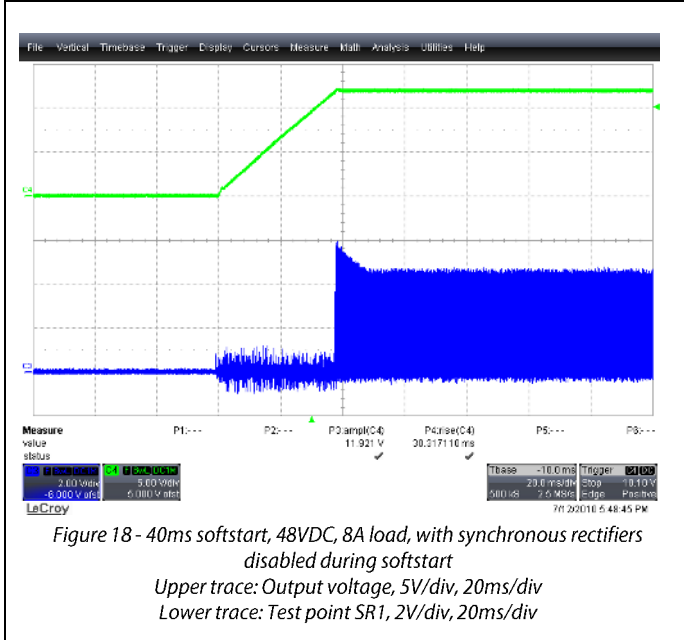

Figure 17 - Startup with 2sec delay, 48VDC, 8A load, with synchronous rectifiers disabled during softstart
 Upper trace: Output voltage, 5V/div, 500ms/div
 Middle trace: PS_ON, 2V/div, 500ms/div
 Lower trace: Test point SR1, 2V/div, 500ms/div

- B. **Softstart ramp and SR blanking:** Figure 18 and Figure 19 show the startup sequence with the synchronous rectifiers enabled/disabled with a 20ms and 40ms softstart ramp respectively.

This test was conducted by monitoring the output voltage (J4 and J5) and the test points SR1/SR2 during a startup condition. The 'Blank SR during softstart' check box and the 'Softstart ramp rate' dropdown menu were appropriately selected.



- C. **SR enable during softstart:** Figure 20 shows the startup sequence with the synchronous rectifiers enabled during softstart. This test was conducted by monitoring the output voltage (J4 and J5) and the synchronous rectifier test points test points (SR1, SR2) during a startup condition. The 'Blank SR during softstart' check box was left unchecked.

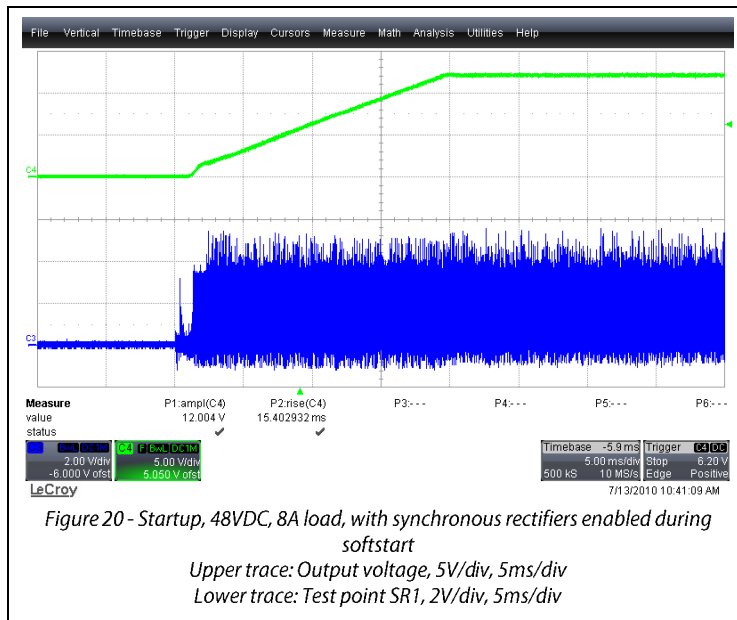

- D. **SR softstart:** This test shows the capability of the softstart ramp or fade in sequence applied to the synchronous rectifiers. The 'Enable SR softstart' button was checked. Figure 21 and Figure 22 show a zoomed in snapshot of the duty cycle at the beginning and end of the softstart ramp

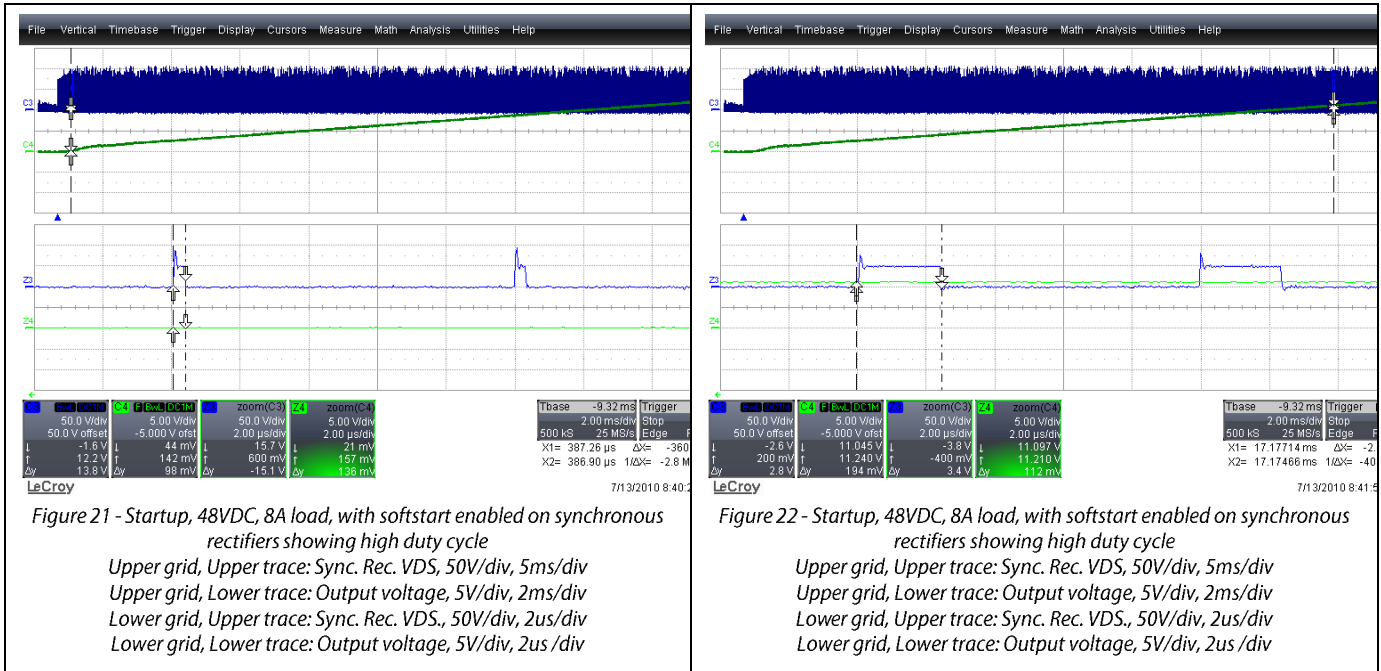

Additional things to try:

- Implementation of different softstart timings in combination with different PS_ON delays.
- Disabling 'Soft Start Always' and evaluating the performance after a fault like UVP/OVP disables the PSU.
- Trimming the RTD register by measuring the temperature at the OrFET and changing the trim setting.
- Disable the OrFET allowing its body diode to conduct the output current. Then set different OTP thresholds.
- Enable Softstart always and see the PSU start a softstart ramp everytime a fault such as a temporary short circuit.

PWM AND SR SETTINGS

The switches on the primary and the synchronous rectifier timings are controlled in this window. This window programs the switching frequency, timings of the synchronous rectifier, the type of modulating edge (rising or falling), modulation type (positive or negative). The IC can be programmed to run at a fixed duty cycle.

The Pulse Skipping mode is activated when the controller requires a duty cycle less than the 'modulation low limit' to maintain output regulation.

Note 1: All the signals shown below represent the gate drive signals at the output pins of the IC.

Note 2: Although the switching frequency can be increased, the software does not account for the dead times and these have to be programmed manually by measuring the propagation delays between the output of the ADP1043A and the gate of the MOSFET. A 200nsec delay is conservative for the evaluation board.

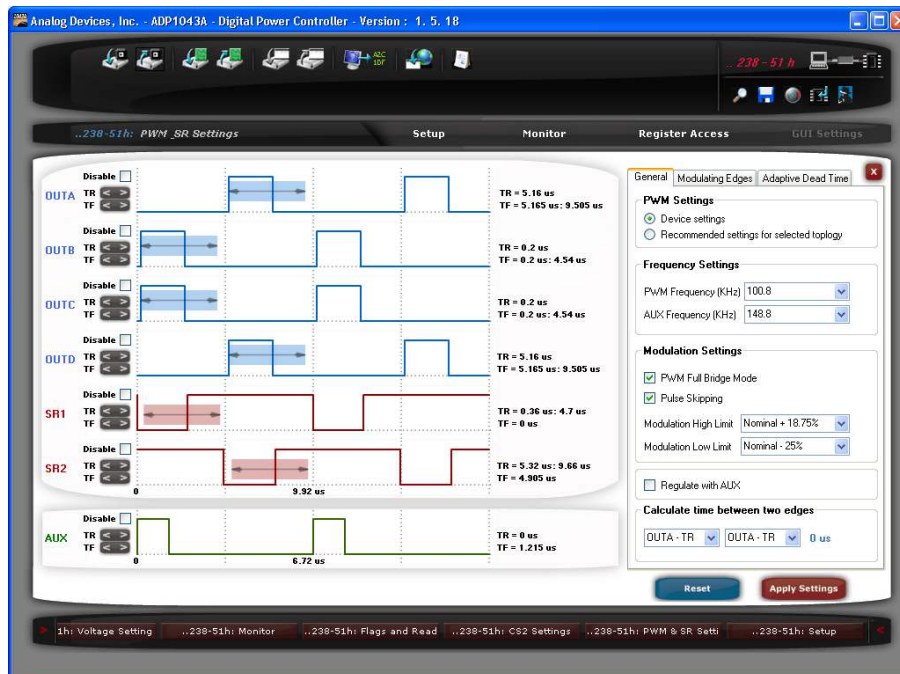

Figure 23 - PWM settings window for the evaluation board

Things to try:

- Referring to the schematic, turning on QA and QB for the entire period of $T_s/2$ (with appropriate deadtimes) and modulating only the bottom MOSFETs.
- Enabling/Disabling Pulse skipping mode and measuring standby power (by disabling the LEDs on the board additional power can be saved).
- Doubling the switching frequency (see accompanying file 200KHz with VS balance.43r) Note: The board is designed to operate at switching frequencies of up to 200kHz with air flow cooling (i.e. a fan). Beyond that, frequency damage to the FETs may occur.
- Programming an imbalance in the ON times of the MOSFETs of each branch and evaluating Volt-Second balance.
- Measuring the effect on standby power by reducing the 'Modulation Low Limit' with/without pulse skipping.
- Run the software in simulation mode and program the PWM settings for a different topology.

CS1 OR INPUT CURRENT SETTING

The input current settings are accessed using the CS1 Settings block. It is used to program the fast and accurate ADCs for pulse by pulse current limiting, leading edge blanking, and enable the volt-sec balance correction to the bottom MOSFETs of the full bridge converter and/or the synchronous rectifiers.

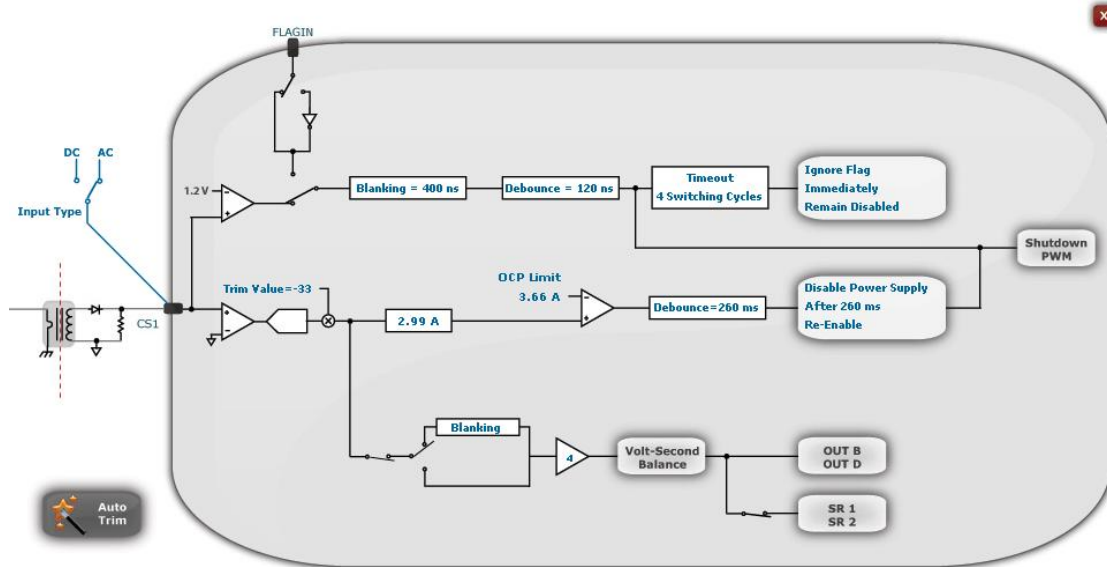

Figure 24 - CS1 Settings Window

Some tests are provided to better appreciate the flexibility of part. In addition to these, some suggestions for further evaluation are also provided.

- A. **CS1 Accurate OCP:** Figure 25 shows the CS1 accurate OCP flag and a reenable after 1 second

This test was conducted by setting the CS1 accurate OCP limit of 2.76A (drop down menu in the GUI) which is lower than the current at minimum voltage. Then the input voltage was ramped down from 60V until the OCP limit was triggered. . Monitoring the PWM signal at test point OUTA clearly shows the shutdown of the PWM.

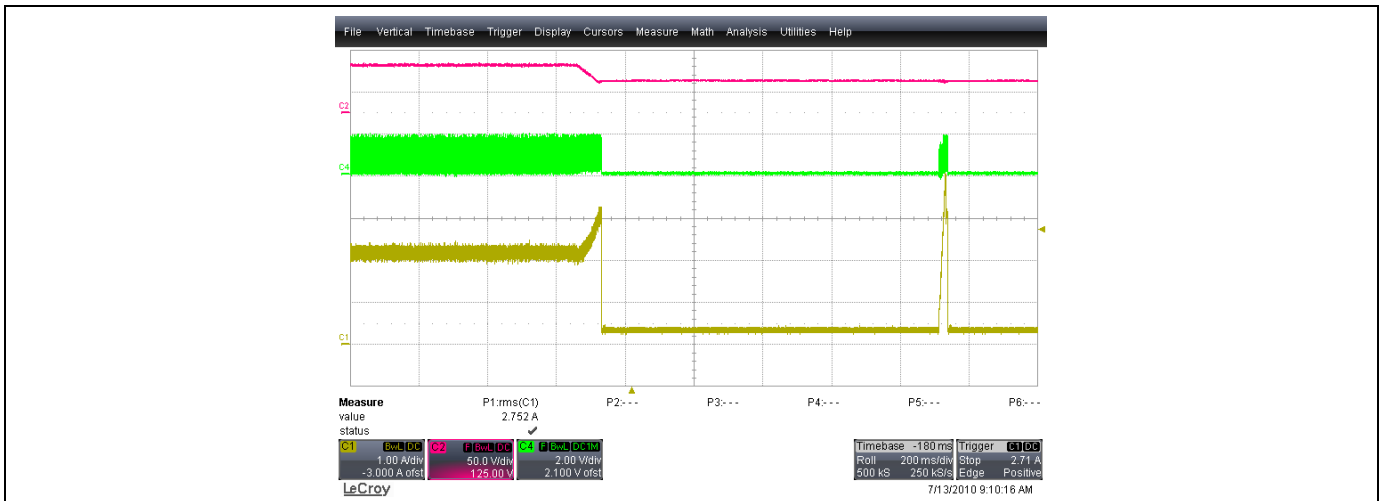

Figure 25 - Accurate CS1 OCP (limit set at 2.76A, re-enable after 1 sec if flag=0)
 Middle trace: Test Point OUTA, 2V/div, 200ms/div
 Lower trace: Input RMS Current, 1A/div, 100ms/div

- B. **Volt Second Balance feature:** The CS1 settings window has the volt second feature that measures the average current in each leg of the full bridge topology. The algorithm reduces (or increases) the conduction time of each branch by varying the pulse width of the MOSFET gate signals applied to OUTB and OUTD depending if there was an increase (or decrease) of current in the corresponding branch. A maximum of 80nsec can be accounted for by this algorithm.

This test was conducted by purposely introducing a mismatch of 75nsec in the PWM settings window. This mismatch clearly shows that the transformer is close to saturation on one end. Figure 27 shows the imbalance and Figure 28 shows the corrected imbalance after the feature was turned on in the GUI by closing the switch. The primary current can be measured using a current probe and by using a small loop of wire in place of jumper L3 or C10 on the board.

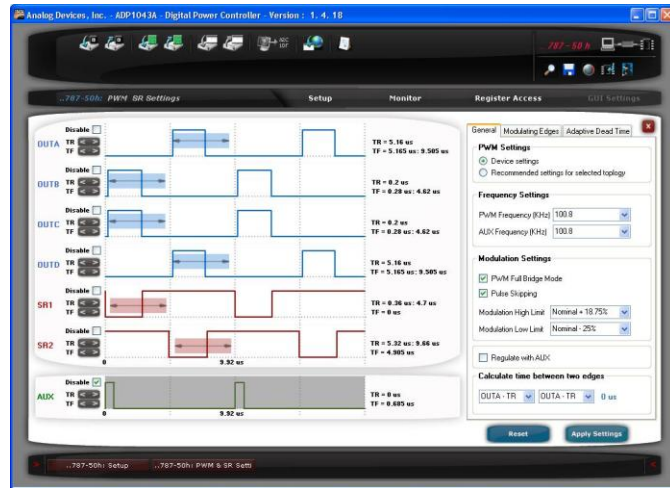

Figure 26 - PWM Settings for programmed 75nsec Volt-Second imbalance on OUTB and OUTC

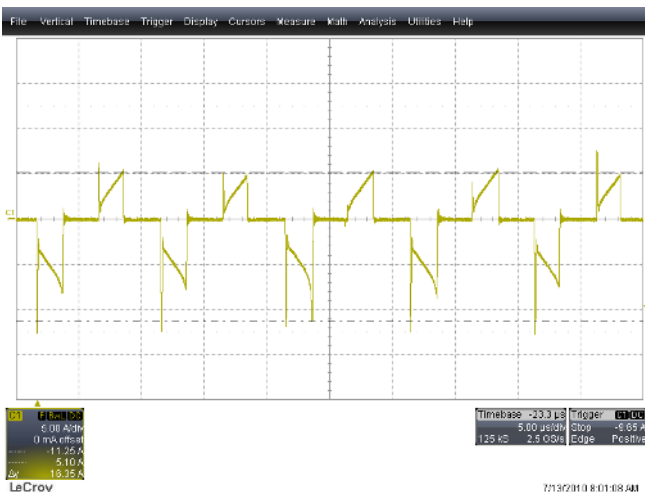

Figure 27 - Primary current with programmed 75ns imbalance, 60VDC, 8A load, 5A/div, 5us/div

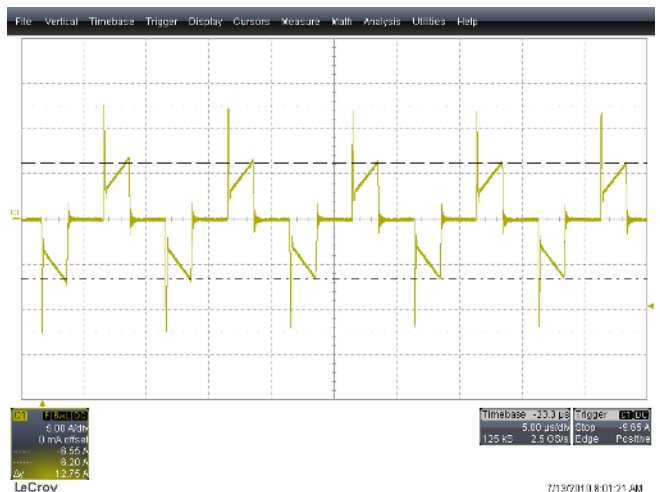

Figure 28 - Primary current after Volt second balance implemented, 60VDC, 8A load, 5A/div, 5us/div

- C. **CS1 Fast OCP:** Figure 29 and Figure 30 show the CS1 fast OCP tripping under a shorted output. In this test the CS1 pulse by pulse current limit was tested during a shorted output. A shutdown was programmed after 4 repetitive OCP limits were triggered.



Figure 29 - Primary current during transformer short (TP16 and TP17), 60VDC. ADP1043 waits for 4 switching cycles before disabling PSU. 5A/div, 5us/div

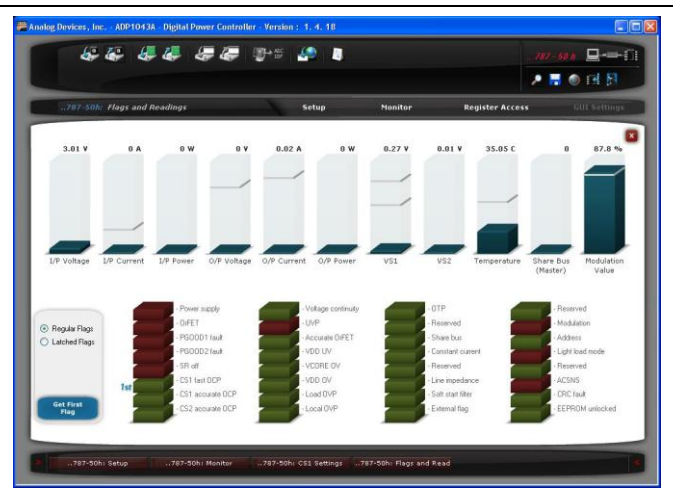

Figure 30 - Corresponding "Flags and Readings" window. CS1 Fast OCP was the first flag that tripped

Additional things to try:

- Programming an external FLAGIN to trip the CS1 fast OCP comparator.
- Enabling/Disabling Volt-Second balance and its associated gain.
- Measuring peak output power at maximum input voltage and by decreasing/increasing the debounce value.
- Use a blocking capacitor (0.47 μ F/100V, metal film) and check the effect of changing the gain in the Volt-second balance on the current waveform.
- Choosing a different value of R10 (on schematic) to get a different range of protection.

CS2 OR OUTPUT CURRENT SETTING

The output current settings window is accessed using the CS2 Settings block. This window also features trimming registers , line impedance feature, threshold for over current protection (OCP), the light load threshold, and constant current mode.

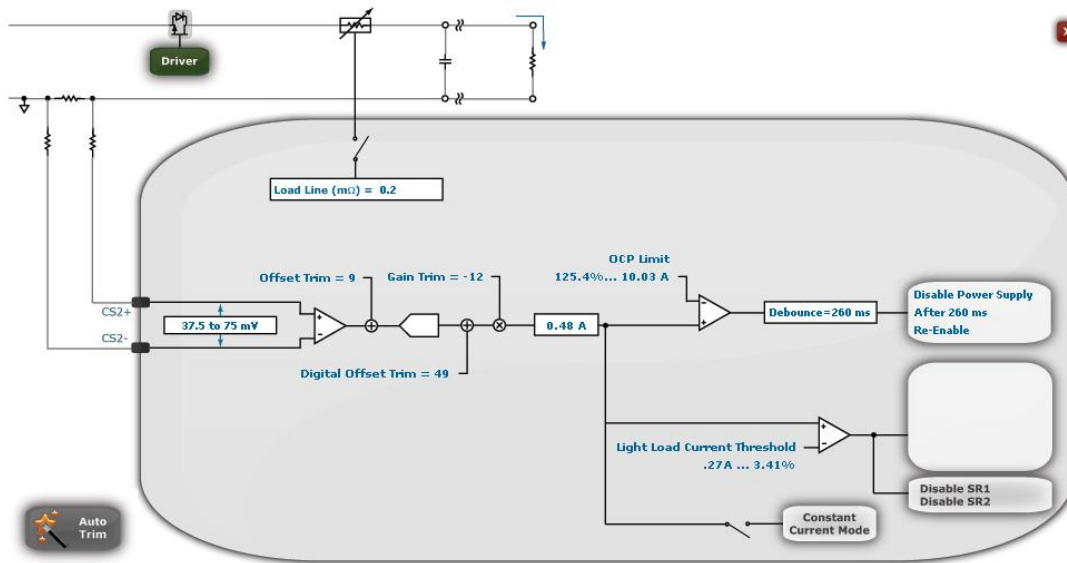

Figure 31 – CS2 Settings Window

The following waveforms display some of the features that can be programmed using this window.

- A. **Over Current Protection (OCP):** Figure 32 and Figure 33 show hysteretic and latching OCP respectively. An over current condition can be easily created by shorting the load or increasing the output current beyond the OCP limit. Different reactions to the fault can be programmed by either re-enabling the PSU after 1 second or a complete shutdown through the drop down menus in the GUI.



Figure 32 - Hysteretic short circuit protection, 60VDC
Upper trace: Output current, 10A/div, 500ms/div
Lower trace: Output Voltage, 5V/div, 500ms/div



Figure 33 - Latching short circuit protection, 60VDC
Upper trace: Output current, 10A/div, 500ms/div
Lower trace: Output Voltage, 5V/div, 500ms/div

- B. **Constant Current Mode:** Figure 34 shows the output voltage ramping down linearly by 60% during constant current mode.

Closing the switch on the trace connected to the Constant Current Block enables CC mode. In this the output voltage linearly drops by 60% of its nominal value when the load current reaches 90% of the OCP limit. In this example, the IC enters CC mode when the load was set to 9.5A which is 94.7% of the OCP limit and output voltage drops to 7 Volts in during CC.

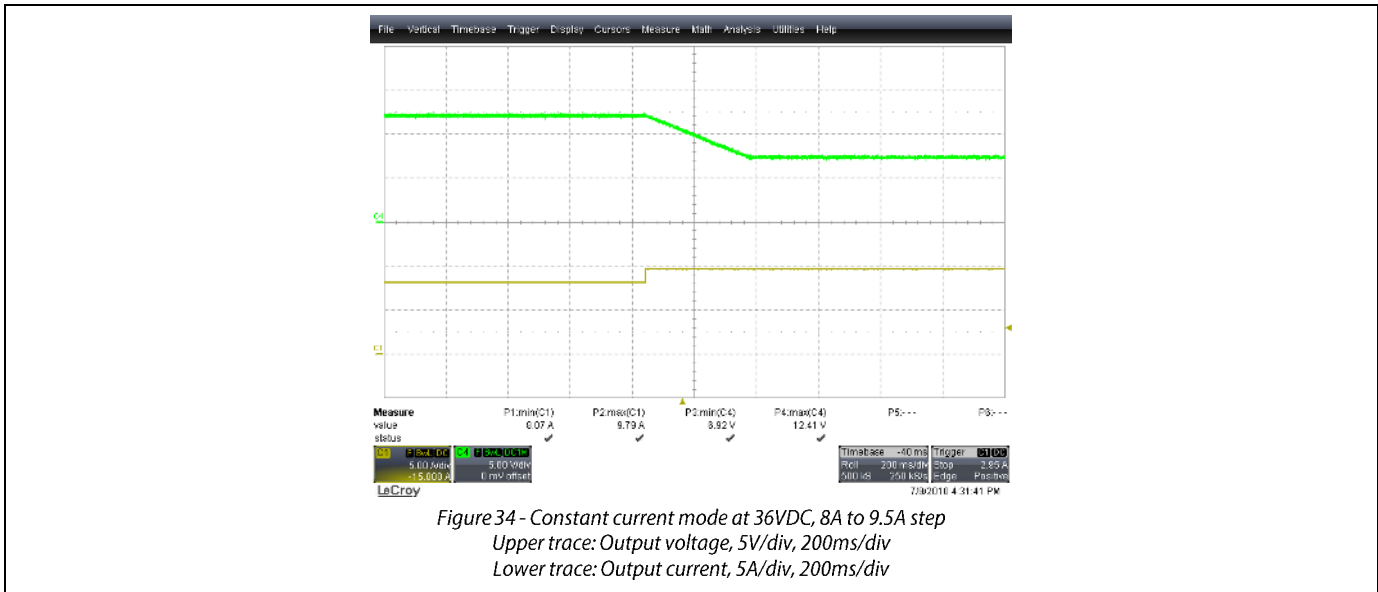

Additional things to try:

- Setting a different light load thresholds and measuring its effect on efficiency
- Using the line impedance feature to simulate the voltage drop through a 2 foot output cable.
- Reducing the current sense resistor value (R17) and changing the range of the full scale voltage drop on CS2+ and CS2-
- Increasing the debounce time on CS2 OCP limit and measuring the peak output power during a short circuit test.
- Setting different OCP limits and setting a different response such as disable SyncRec

LIGHT LOAD MODE

The ADP1043A can be programmed to optimize performance when the output current drops below a certain level. The light load threshold is set in a manner to reduce the losses in the synchronous rectifiers to enter into DCM and reduce the power loss in the SR drivers and increase efficiency. A hysteresis is provided on this threshold to avoid oscillations.

When operating in light load mode the corresponding flag will be set as well as the SR off flag as shown in the monitor window (Synchronous rectifiers turned red in figure below), and the light load filter settings will be used. Using this in combination with Pulse Skipping aids in reducing standby power consumption. The ACSNS flag is used to sense the voltage at the front side of the inductor connected to the transformer (T2).

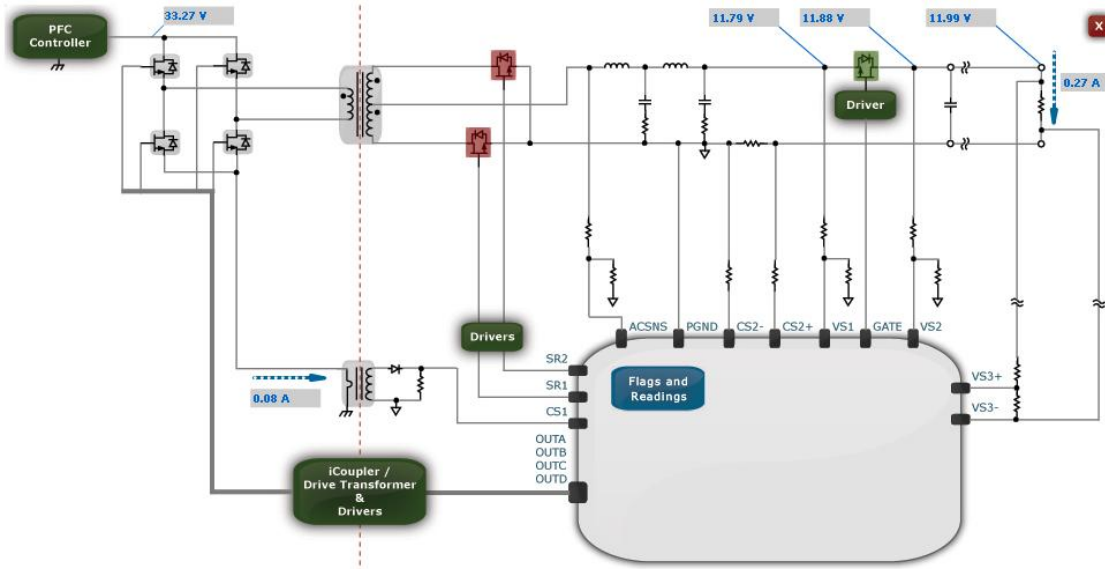

Figure 35 - SR Automatic Disabled in Light load mode

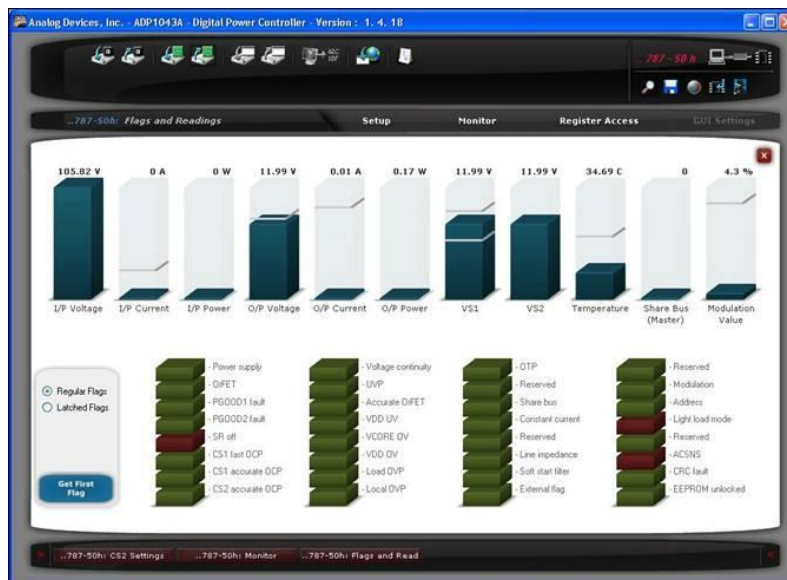

Figure 36 - ACSNS flag tripped during Light load mode

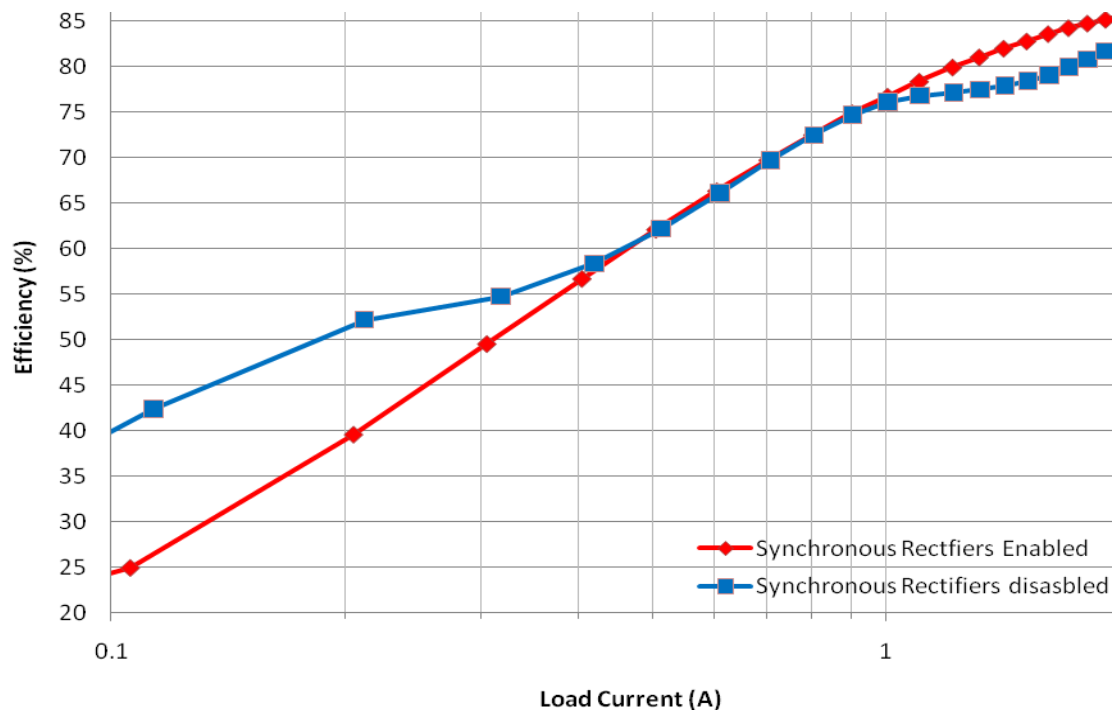

Figure 37 - Efficiency vs Light load current at 48VDC showing optimal light load threshold between 500-900mA

OUTPUT VOLTAGE SETTINGS

This window sets all the parameters related to the output voltage, including trimming, overvoltage protection (OVP) and undervoltage protection (UVP) protection. There are three points where the output voltage is sensed using the ADP1043A namely, before the ORFET (local OVP), after the ORFET (also local OVP), and at the load (remote OVP). An over voltage condition at the load is termed as remote OVP whereas at the other two locations is termed as local OVP.

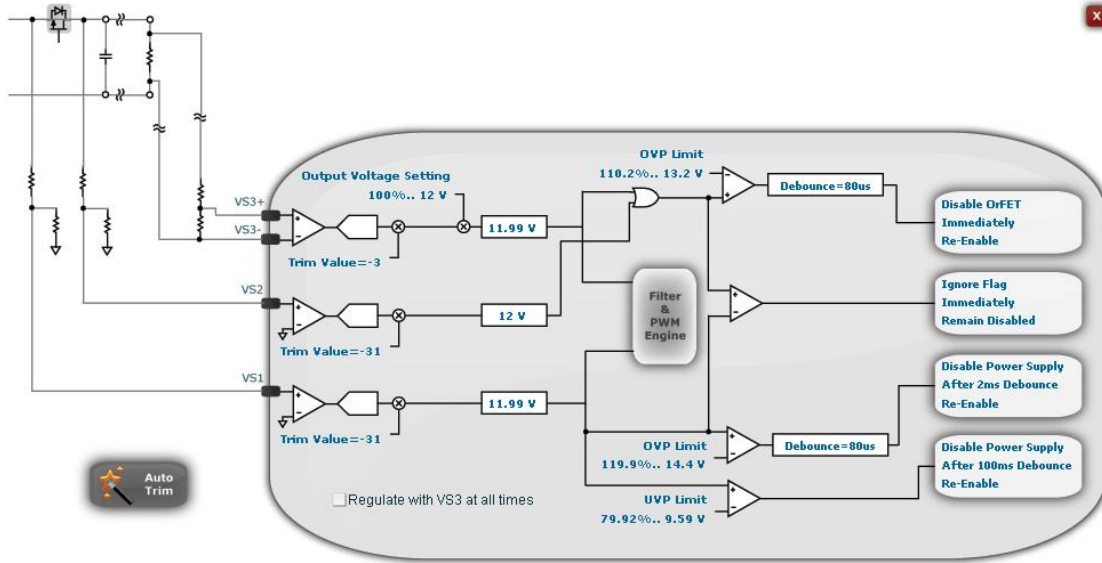

Figure 38 - Voltage Settings Window

The following waveforms display some of the features that can be changed using this window.

- A. **Under Voltage Protection (UVP):** Figure 39 and Figure 40 show latching and hysteretic UVP respectively.

This test can be conducted in a number of ways, the simplest of which would be to set the 'VS3 Output Voltage Setting' under the programmed UVP threshold using the drop down menu in the GUI. Alternately, the duty cycle can be clamped to a lower value than its required value. Under certain conditions even a shorted load or an internal short (shorting the synchronous rectifiers) can cause a UVP condition. Hysteretic (enable after 1 sec) and latching (remain disabled, only PS_ON can reenale) are the programmed choices for the faults.

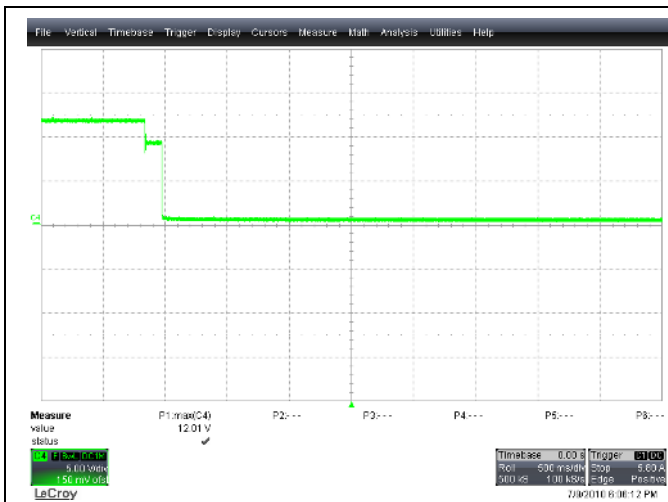

Figure 39 - Latching VS1 Under Voltage Protection (set to 9.2V)
Output voltage, 5V/div, 500ms/div

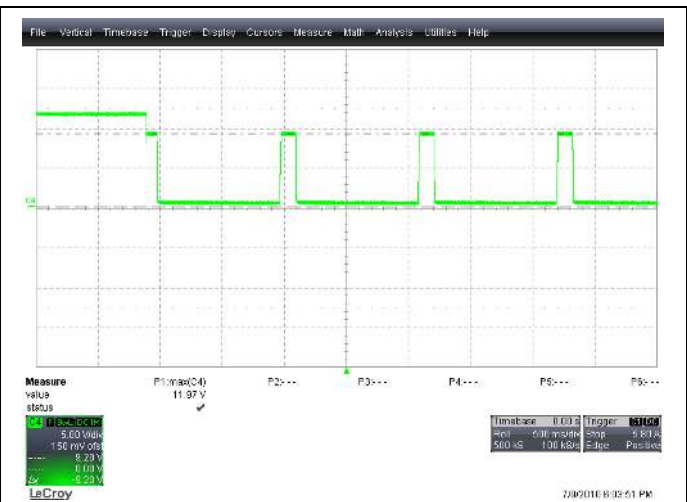

Figure 40 - Hysteretic VS1 Under Voltage Protection (set to 9.2V)
Output voltage, 5V/div, 500ms/div

B. **Over Voltage Protection (OVP):** Figure 41 and Figure 42 show latching and hysteretic OVP respectively.

This test can be easily performed setting the VS3 regulation point beyond the OVP threshold. Another method how an OVP flag can be tripped is by suddenly opening the control loop (open R10 or short R11 on the daughter card). Hysteretic (enable after 1 sec) and latching (remain disabled, only PS_ON can reenable) are the programmed choices for the faults in the drop down menu provided in the GUI.

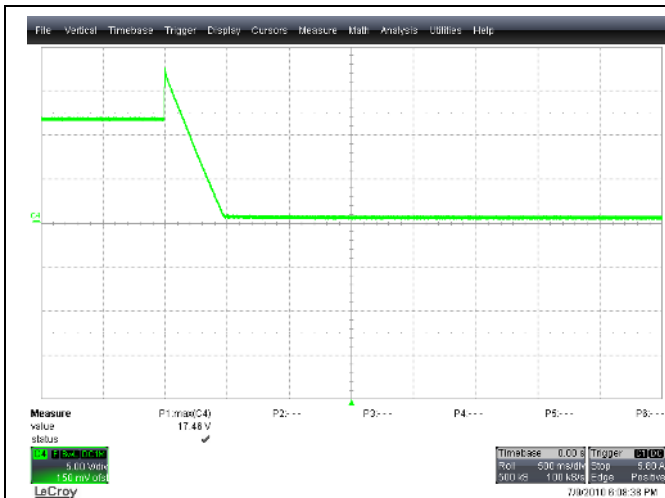

Figure 41 - Latching VS3 Over Voltage Protection (set to 17.5V)
Output voltage, 5V/div, 500ms/div



Figure 42 - Hysteretic VS3 Over Voltage Protection (set to 17V)
Output voltage, 5V/div, 500ms/div

Additional things to try:

1. Using Auto trim to precisely set the voltage at the terminals of the board.
2. Setting OVP and UVP limits to $\pm 5\%$ of nominal output voltage and measuring its effect on startup
3. Regulating with VS3 at all times and evaluating the transient response.
4. Use this voltage continuity feature to detect a voltage drop more than 100mV between VS1 and VS2 or VS2 and VS3.

DIGITAL FILTER SETTINGS AND TRANSIENT ANALYSIS

The digital filter can be changed using the software by manipulating the position of the poles and zeros (red and green circles in figure below) in the Laplace domain. The ADP1043A allows two different sets of compensation to be programmed, one at light load and one at heavy load.

A type 3 compensation is implemented in the ADP1043A. The first pole (to eliminate steady state error) is indirectly accessed through the placement of the first zero. The second pole can be freely placed, but the third pole (high frequency gain) is fixed at half the switching frequency. There is an additional constraint in moving the poles and zeros and it is that the software allows the poles and zeros to be moved only in a manner that keeps the slopes between them equal to $\pm 20\text{dB/dec}$.

WARNING: While varying the compensation parameters is possible while the part is running, the wrong combination of parameters can cause the system to become unstable.

The following figures are provided to demonstrate the performance of the PSU as well as the ease with which the GUI can be used to change the dynamic response of the system.

- A. **Closed Loop System:** Figure 43 and Figure 44 show the bode plot of the system. The validity of this plot depends highly on the proper characterization of the output inductor and capacitor and their respective parasitic components namely the DC resistance and ESR. The GUI displays the closed loop crossover frequency, phase margin as well as individual gain and phase plots for the LC filter, digital filter and the closed loop scenarios.



Figure 43 - Full loop gain and phase for Light Load mode



Figure 44 - Full loop gain and phase for Steady State load

B. Transient Response for load step: Figure 45 and Figure 46 show the transient response at 36 and 60VDC respectively.

A dynamic load from 1-8A (slew rate $1A/\mu s$) at a frequency of 20-25Hz can be set up to conduct this test. The output voltage must be measured at the connectors J4 and J5 with very small loop area between the positive and negative of the probes to minimize noise.

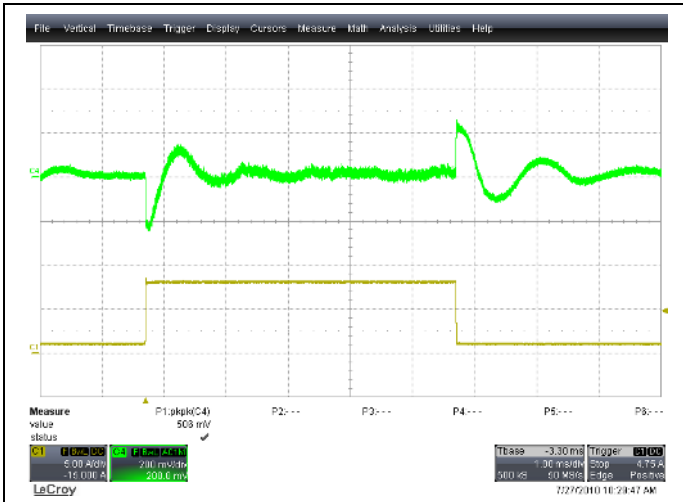

Figure 45 - Transient Analysis, 1A - 8A step load, 36VDC
Upper trace: AC coupled output Voltage, 200mV/div, 1ms/div
Lower trace: Input current, 5A/div, 1ms/div

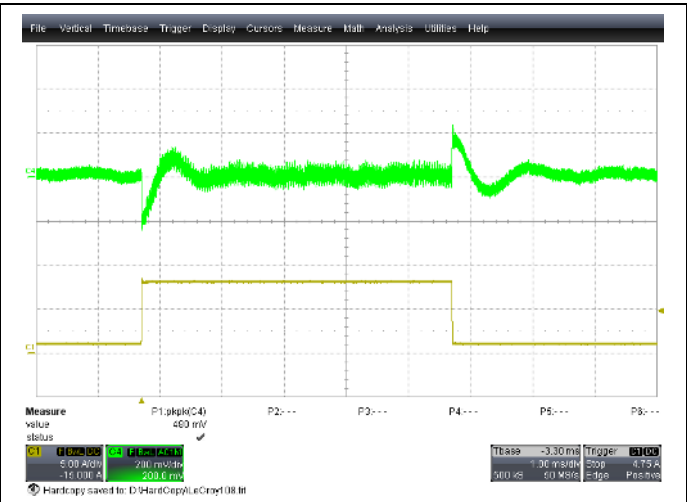

Figure 46 - Transient Analysis, 1A - 8A step load, 60VDC
Upper trace: AC coupled output Voltage, 200mV/div, 1ms/div
Lower trace: Input current, 5A/div, 1ms/div

C. Transient Response under DCM/CCM transition: Figure 47 shows the dynamic response of the system under a load step of 0.2-5A (slew rate $1A/\mu s$). A low starting current is chosen so that the converter is forced to disable the synchronous rectifiers due to the light load threshold setting in the CS2 window. In contrast, Figure 48 shows the response with the light load threshold set at 0A (SR always on). This forces the output inductor current to be continuous and the converter remains in CCM despite the load condition drawing energy from the output capacitor to charge the inductor.

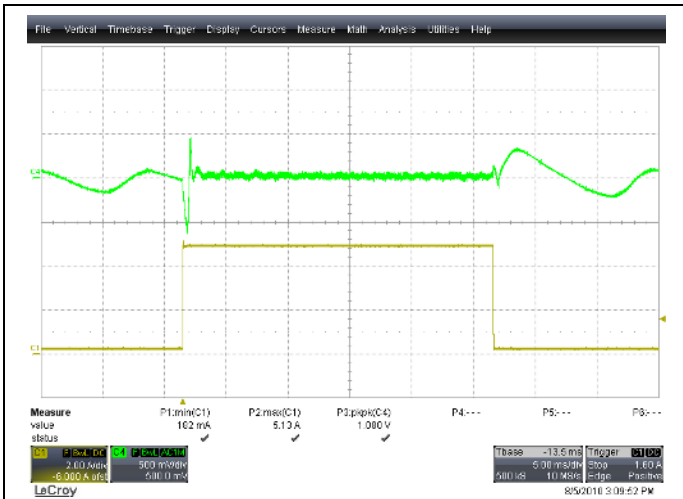

Figure 47 - Transient Analysis, 0.2A - 5A step load, 48VDC, SR disabled at light load
Upper trace: AC coupled output Voltage, 500mV/div, 5ms/div
Lower trace: Input current, 2A/div, 5ms/div

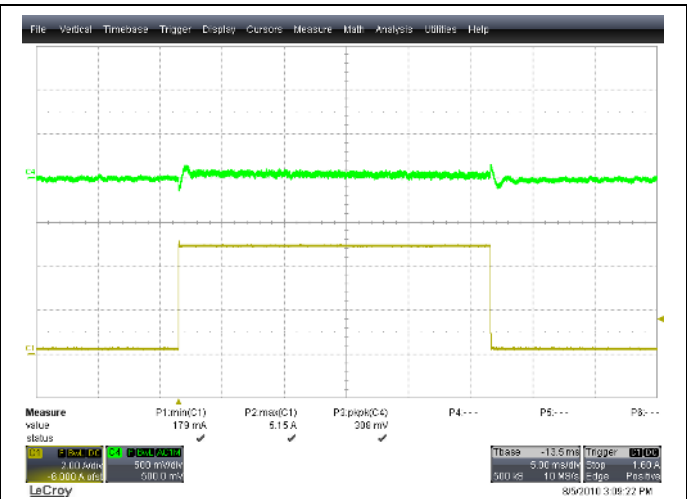

Figure 48 - Transient Analysis, 0.2A - 5A step load, 48VDC, SR enabled at light load
Upper trace: AC coupled output Voltage, 500mV/div, 5ms/div
Lower trace: Input current, 2A/div, 5ms/div

Additional things to try:

- a) Tweaking the light load transient response (0-500mA step load).
- b) Increasing the crossover frequency and measure transient response
- c) Measuring transient response under different load steps
- d) Increasing the phase margin to 60 degrees by cancelling the double pole of the output LC filter by the two zeros of the Type 3 compensation.
- e) Measuring the transient response (0.2A - 8A) by enabling the light load mode at 0.0A (SR always enabled) thus keeping the output inductor in CCM regardless of the load.
- f) Measuring the dynamic response at 200KHz switching frequency.

ORFET SETTINGS

The ADP1043A includes features such as hot swapping as well as protection against a reverse current from other PSUs connected on the same bus with the use of active ORing (ORFET). This window sets the turn on condition of the OrFET depending upon the voltage threshold across it as well as its turn off depending upon the reverse current flowing in the current sense resistor CS2⁻ - CS2⁺. This enables hot swapping and allows additional PSUs to be connected to the same bus without any interruption with sufficient protection.

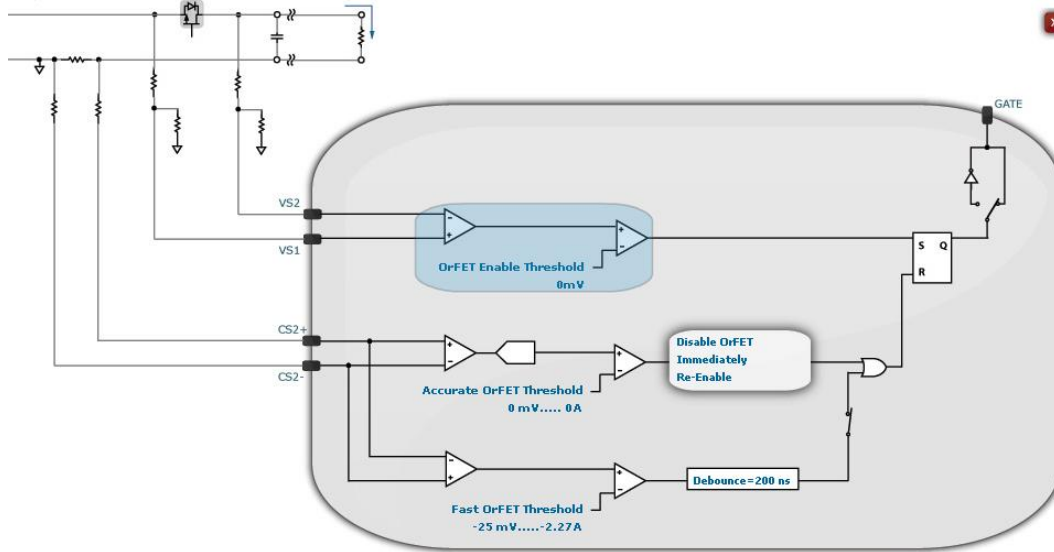
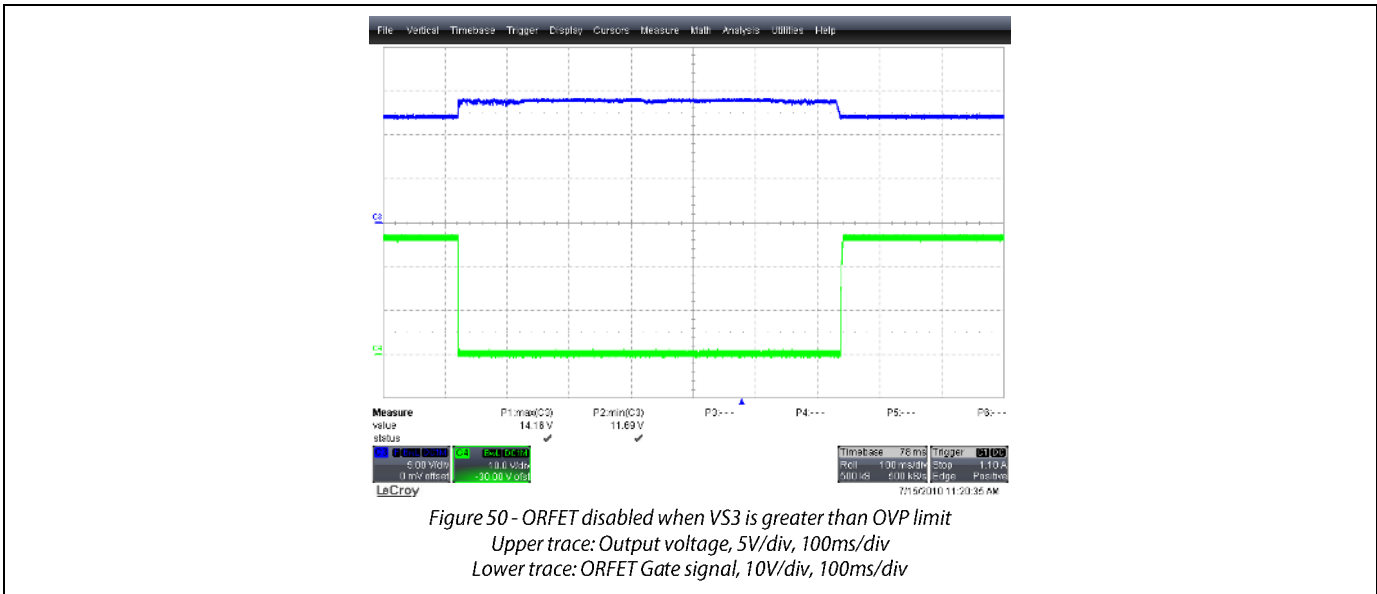

Figure 49 - OrFET Settings Window

The following waveforms display some of the features that can be changed using this window.

- A. **Load OVP action on OrFET:** Figure 50 shows the OrFET being disabled when a bus voltage is greater than the local voltage. A DC power supply can be connected to the output terminals of the board (J4, J5). Care should be taken to ensure that the output voltage is not beyond the voltage rating of the output capacitor (C7) and the absolute maximum VCC rating of the SR driver (U1). Here the load OVP flag is used to protect the PSU by disabling the OrFET. The body diode of the MOSFET (Q1) is reversed biased during this condition.



B. **Internal short circuit action on OrFET:** Figure 51 and Figure 52 shows the OrFET disabled during an internal short circuit and its corresponding flag. An internal short of the synchronous rectifiers can be simulated in the PWM settings or by physically shorting the drain pin of Q2 and Q3. The CS1 fast OCP or the UVP flag can be set to disable the OrFET.

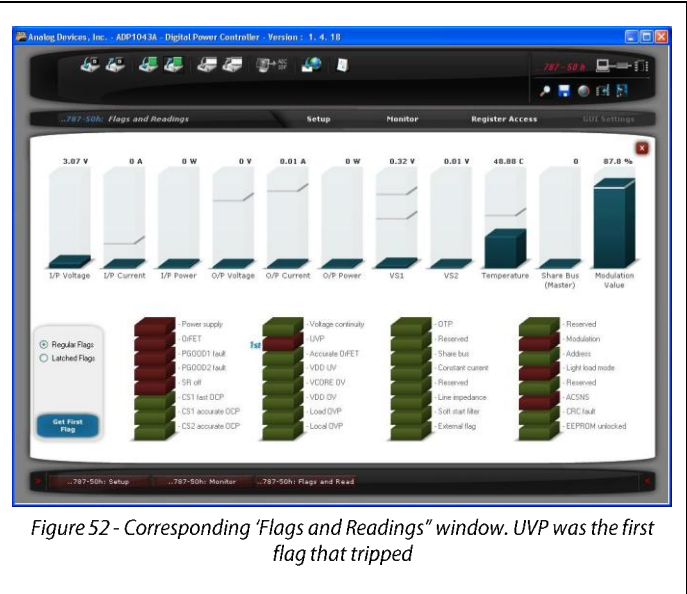
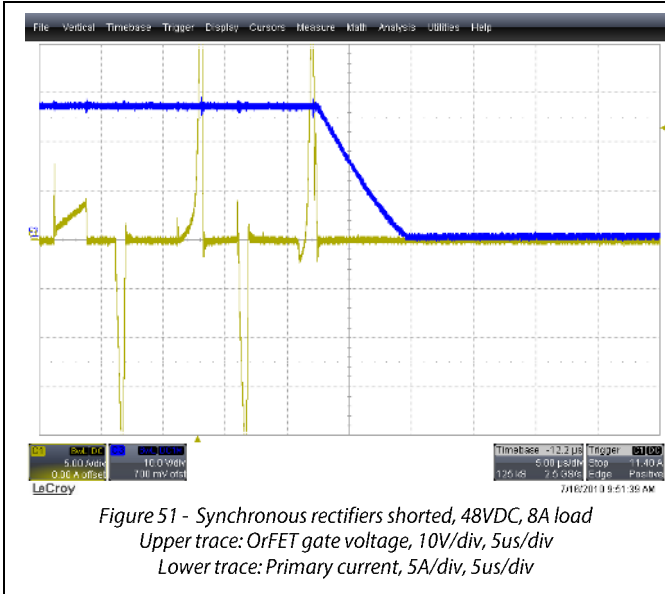

C. **UVP action on OrFET:** Figure 53 and Figure 54 show the disabled OrFET signal during a UVP fault and reenable after the flag is cleared.

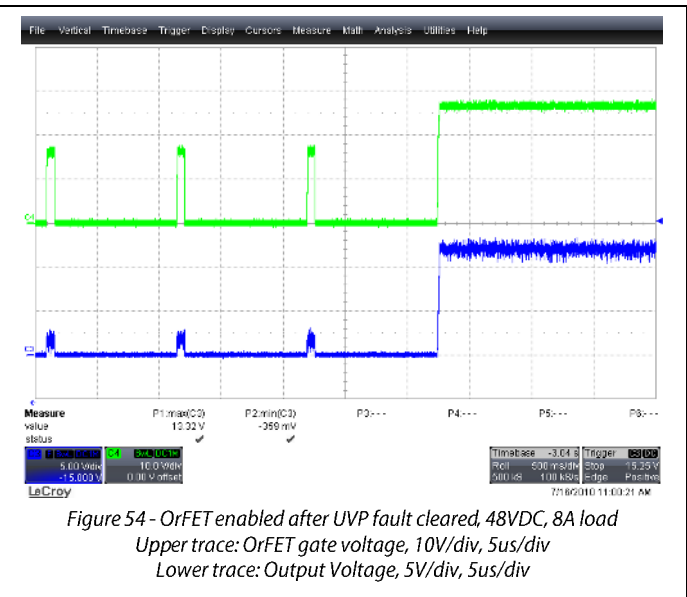
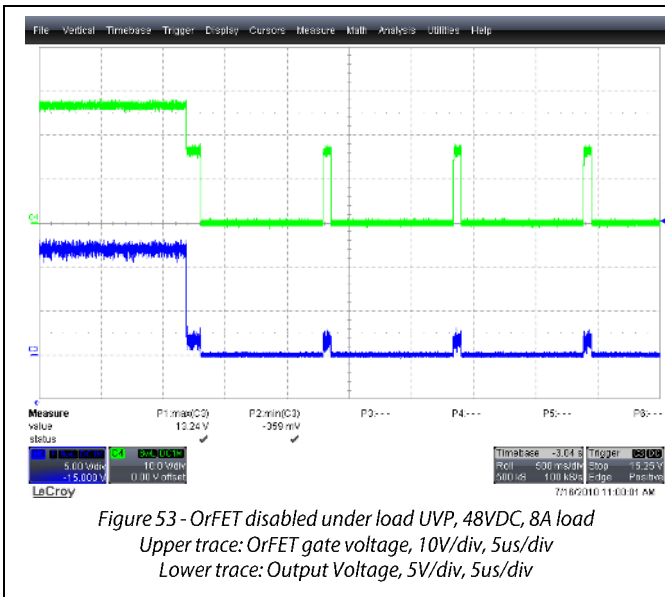

Additional things to try:

- a) Disable OrFET using CS1 OCP, Load UVP or fast OrFET when an internal short circuit occurs.
- b) Disable OrFET using VS3 when $V_{OUT} > OVP$ limit.
- c) Disable ORFET using ACSNS in light load mode to minimize light load standby consumption.

APPENDIX I – SCHEMATIC (MAIN BOARD)

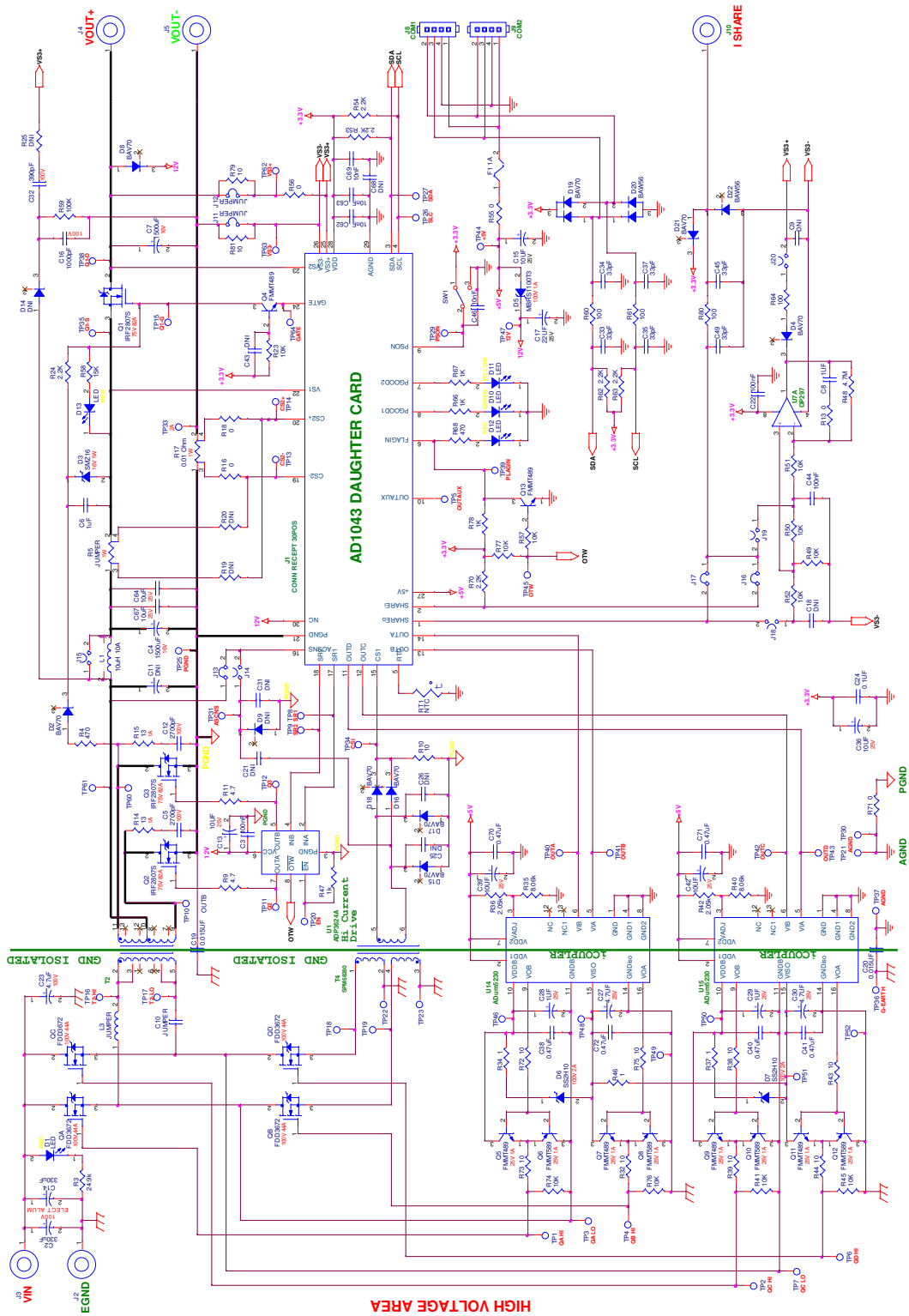

APPENDIX II – SCHEMATIC (DAUGHTER CARD)

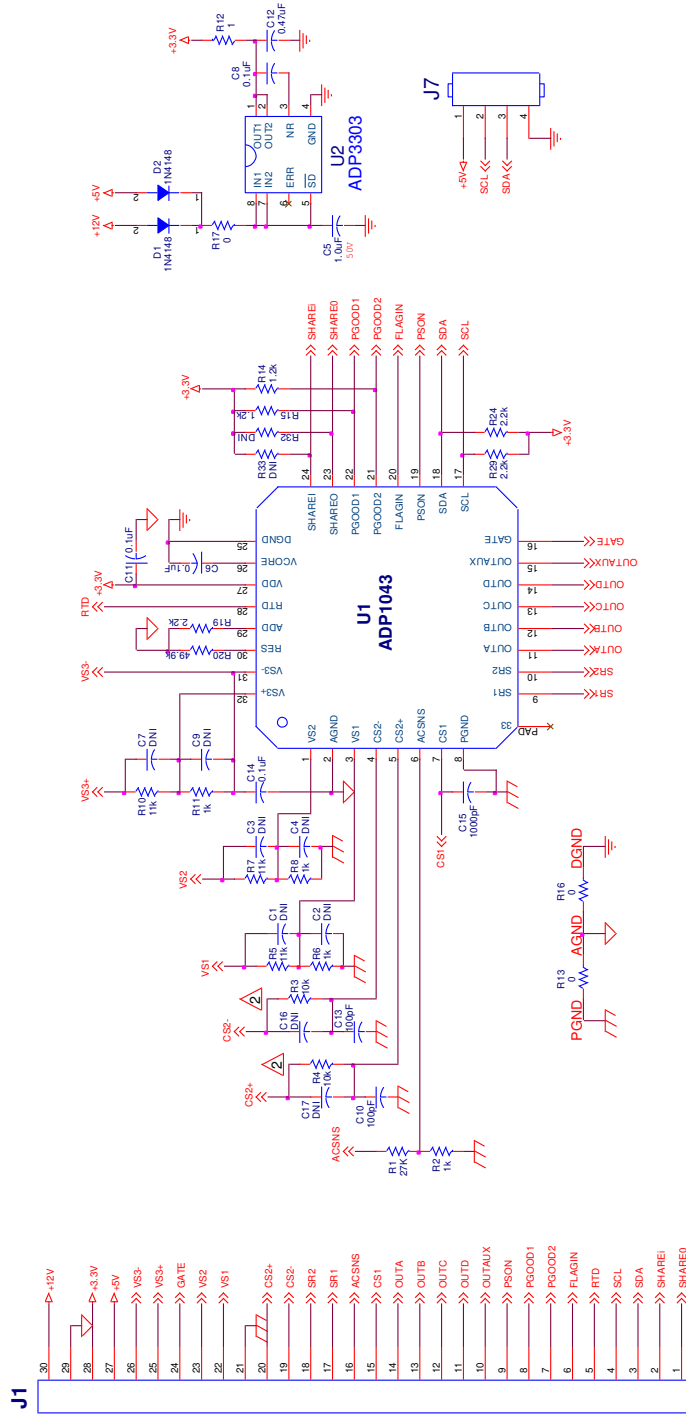

	R3	R4	C10	C13	C16	C17
Low Side	10k	10k	DNI	DNI	DNI	DNI
High Side	110k	110k	DNI	DNI	139pF	33pF

1: R3, R4, R5, R6, R7, R8, R10, R11 ARE 0.1% 25ppm

NOTES : UNLESS OTHERWISE SPECIFIED.

APPENDIX III – LAYOUT (MAIN BOARD)

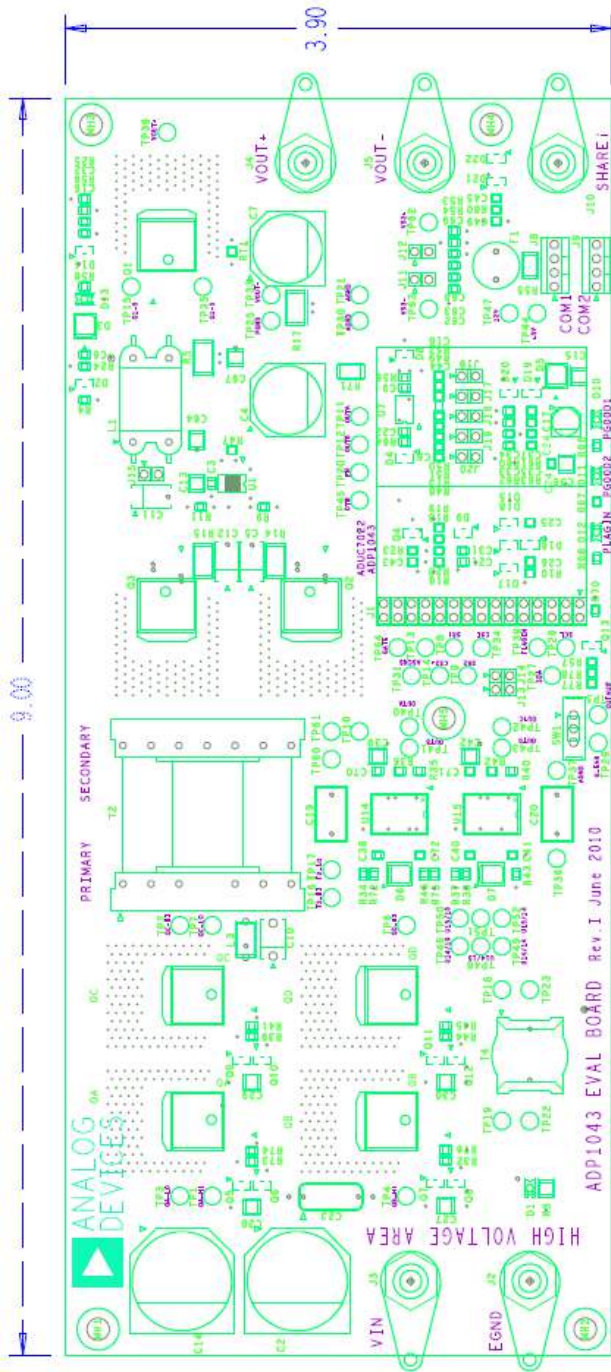

Figure 55 – Layout, Silkscreen layer, dimensions in inches

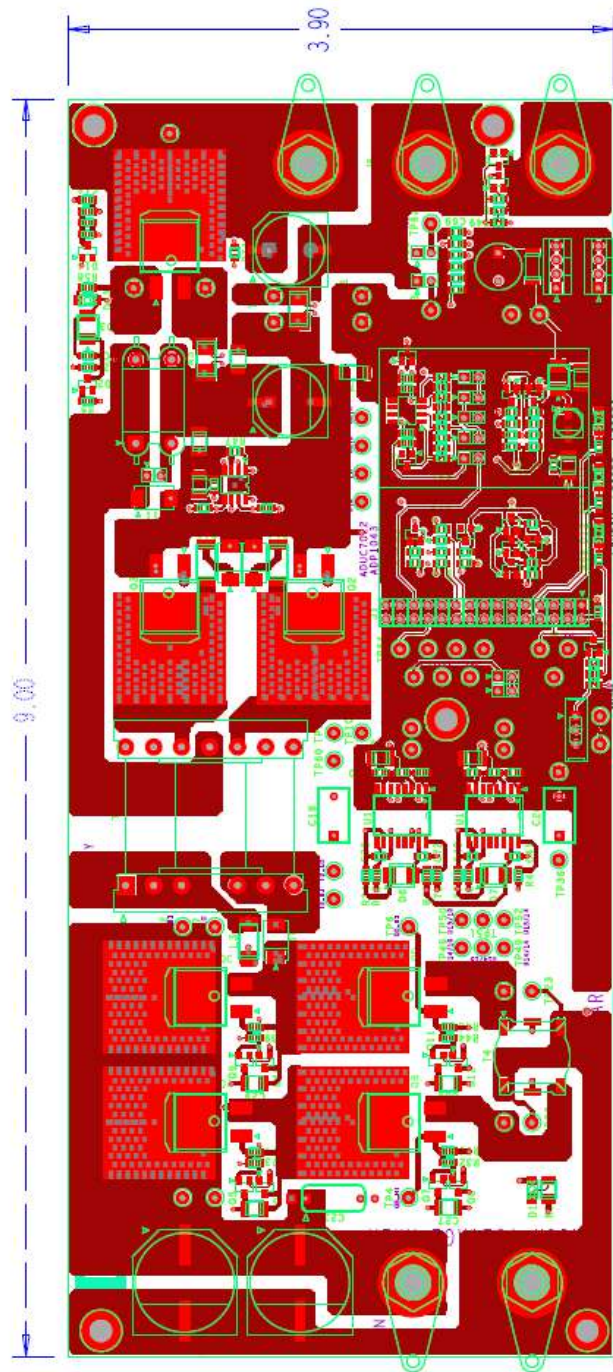

Figure 56 – Layout, Top layer, dimensions in inches

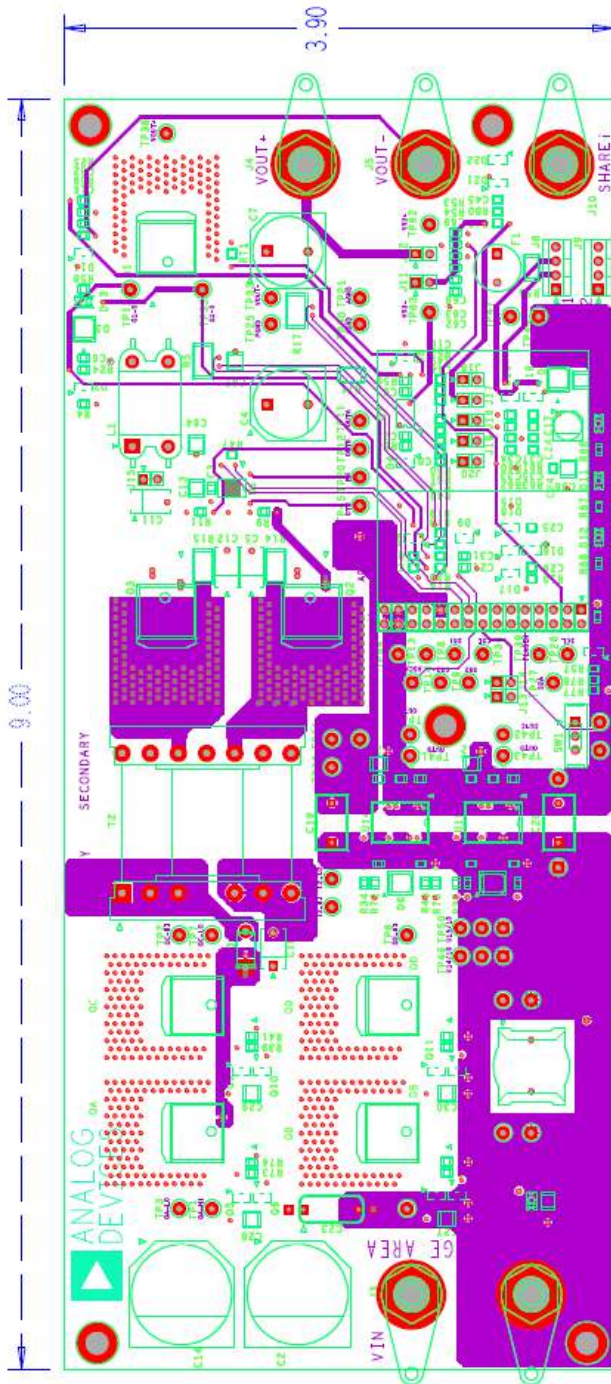

Figure 57 - Layout, inner layer 1, dimensions in inches

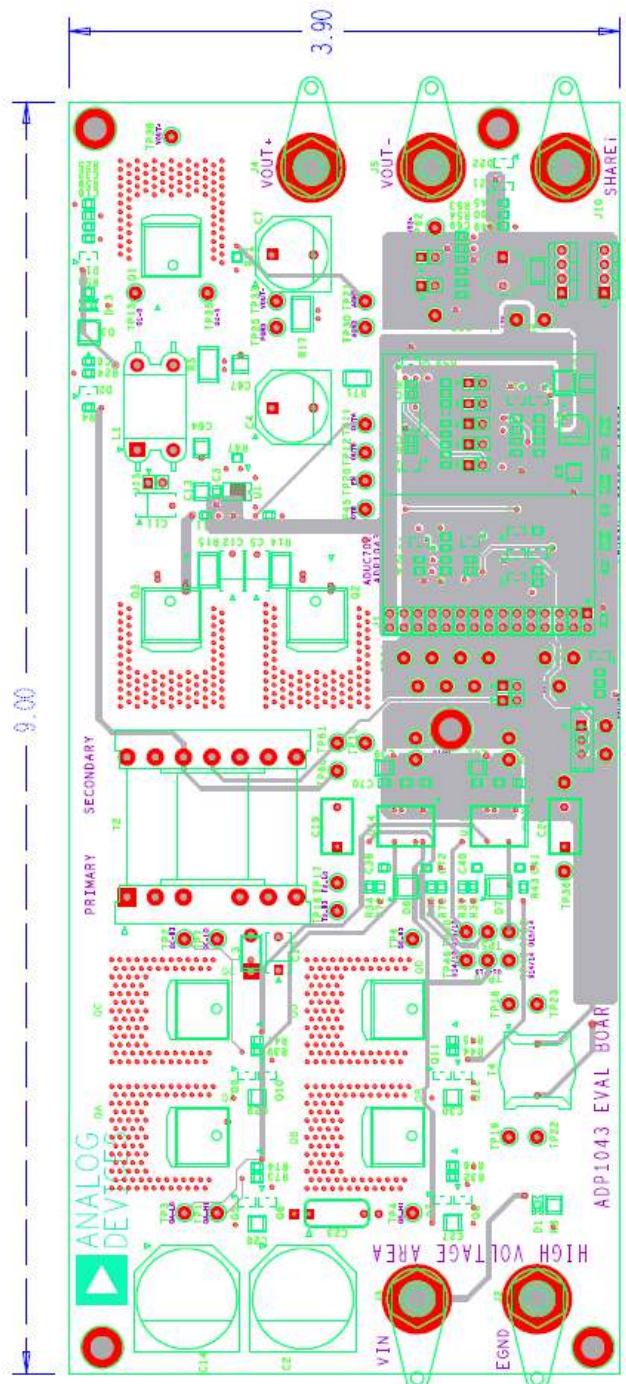

Figure 58 - Layout, inner layer 2, dimensions in inches

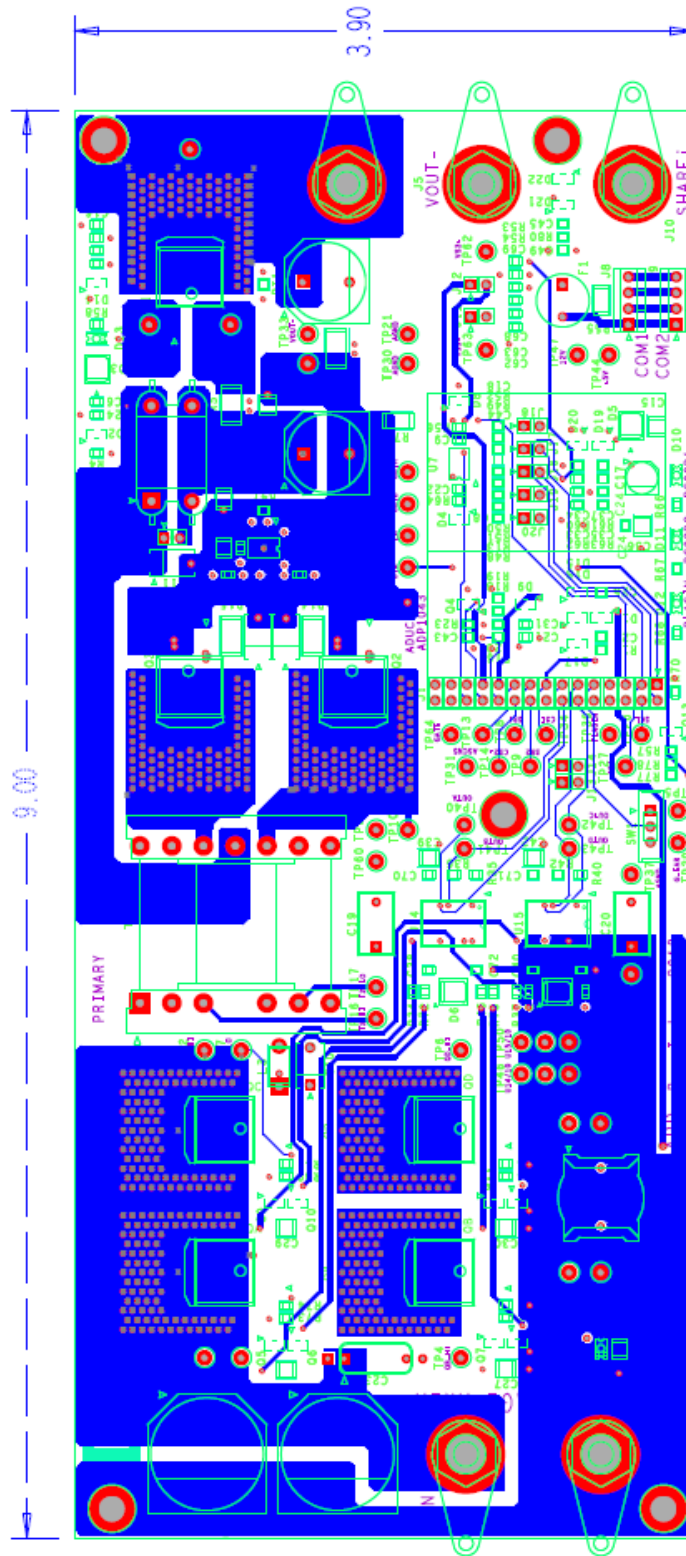

Figure 59 - Figure 54 - Layout, bottom layer, dimensions in inches

APPENDIX IV – LAYOUT (DAUGHTER CARD)

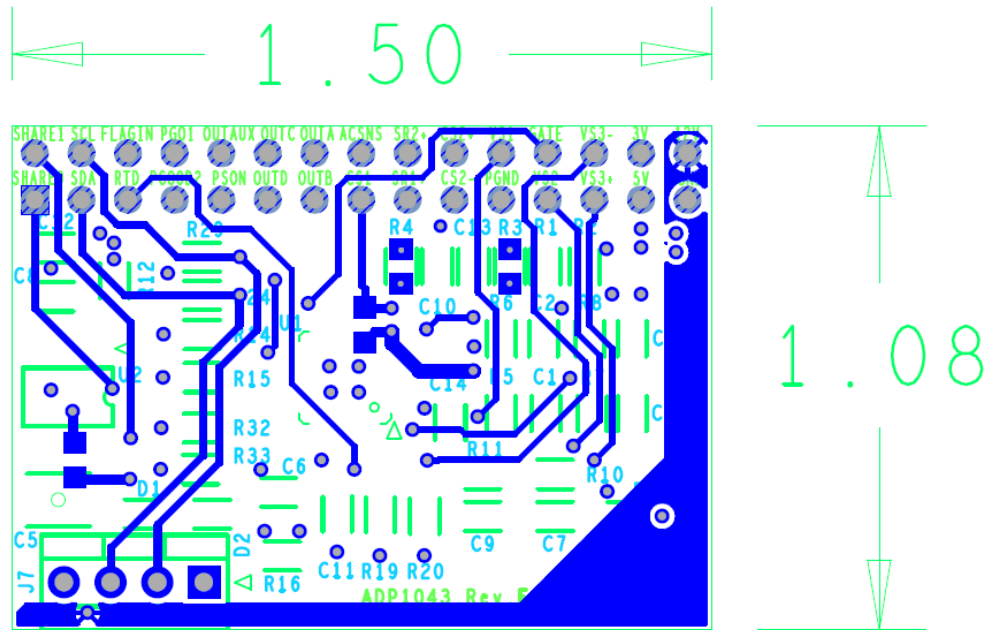

Figure 60 - Bottom Layer, dimensions in inches

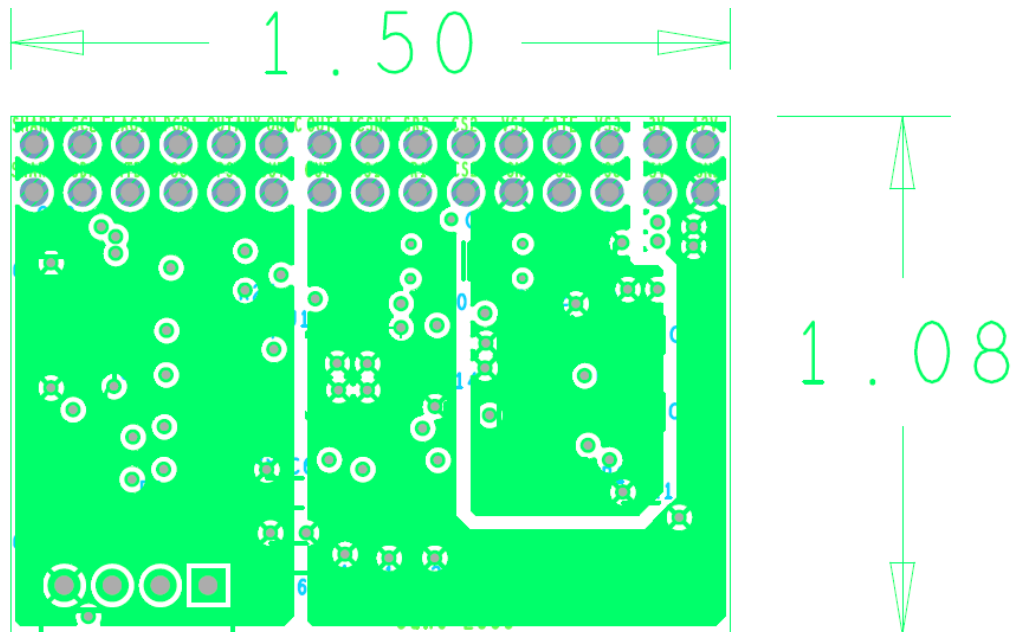

Figure 61 - GND Layer, dimensions in inches

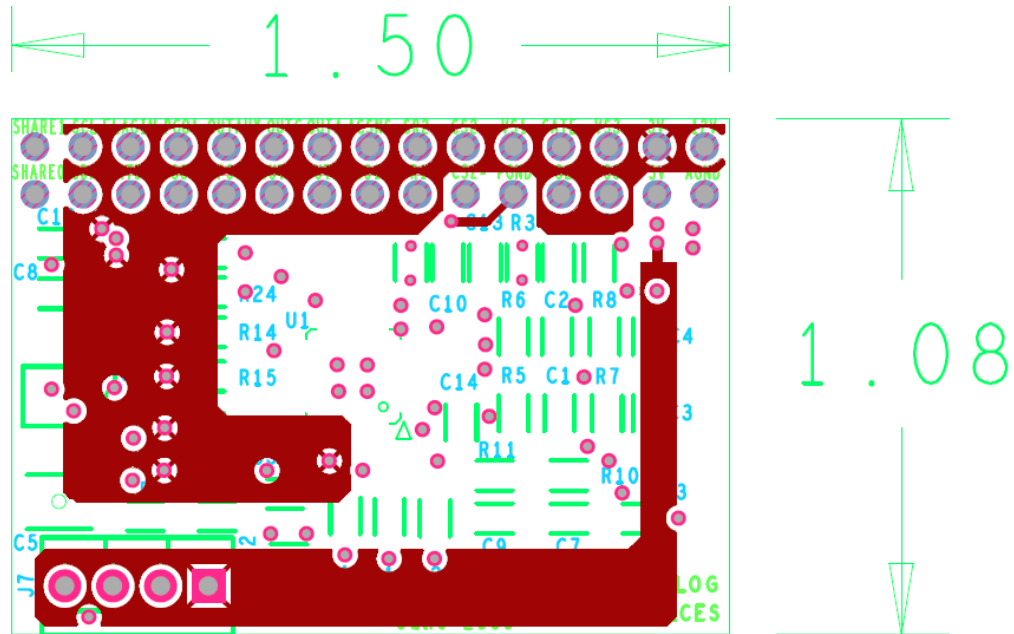

Figure 62 - Power Layer, dimensions in inches

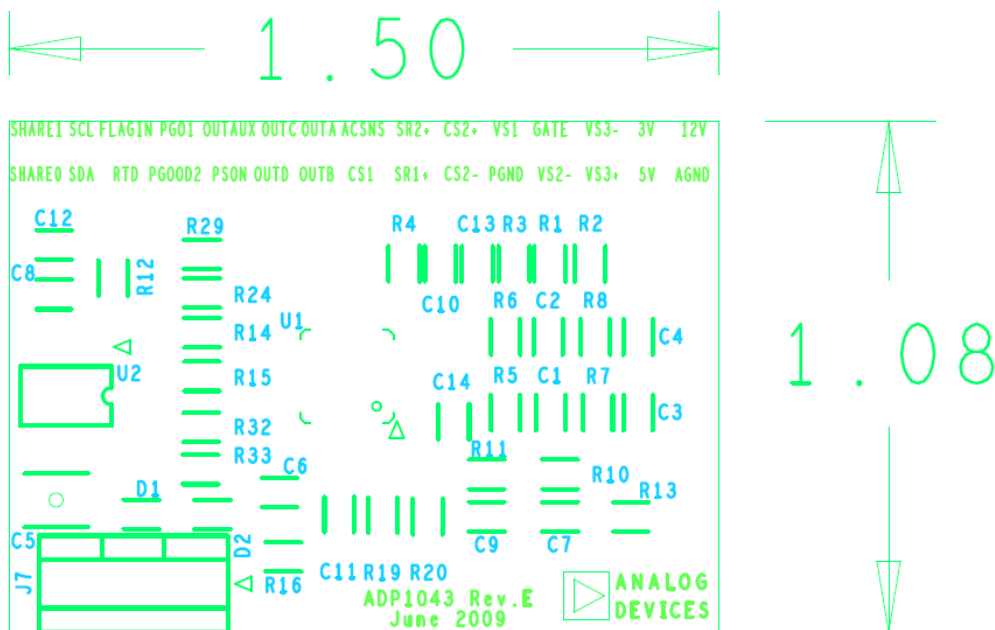

Figure 63 - Figure 53 - Silkscreen Layer, dimensions in inches

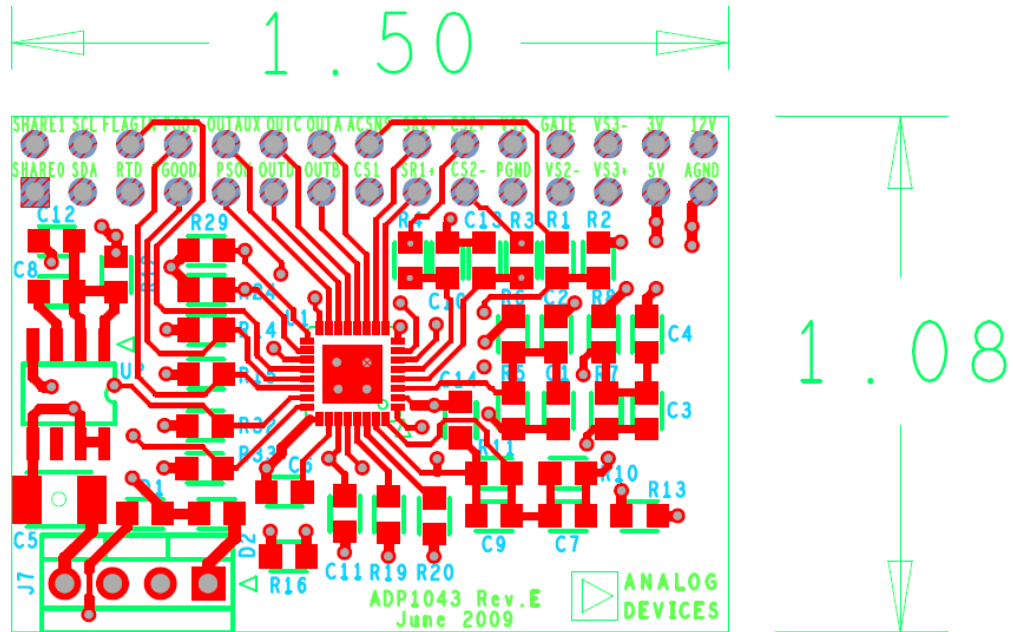

Figure 64 - Figure 54 - Figure 53 - Top Layer, dimensions in inches

APPENDIX V - TRANSFORMER SPECIFICATION

PARAMETER	MIN	TYP	MAX	UNITS	NOTES
Core and Bobbin					ETD 29 Horizontal, 3F3 or equivalent
Primary inductance	77			μH	Pins 2,3 to pin 4,5
Leakage inductance		2.31	3	μH	Pins 2,3 to pin 4,5 with all other windings shorted
Magnetizing current		1.58		A	
Resonant frequency	850			KHz	Pins 2,3 to pin 4,5 with all other windings open

Table 5 - Transformer specifications

PARAMETER	MIN	TYP	MAX	UNITS	NOTES
Core					0077720A7, KoolMu, Magnetics Inc.
Pearmeability (μ _o)	75				
Inductance	6.5	10		μH	
DC resistance			6	mΩ	

Table 6 - Output Inductor specifications

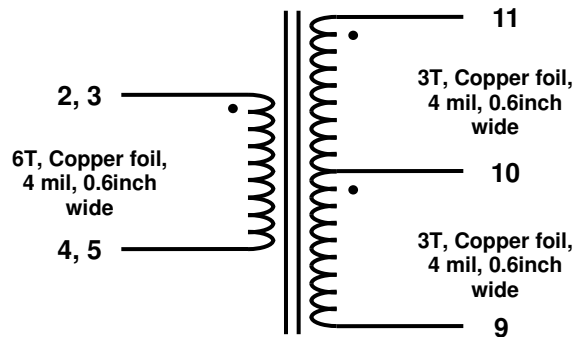

Figure 65 - Transformer electrical diagram

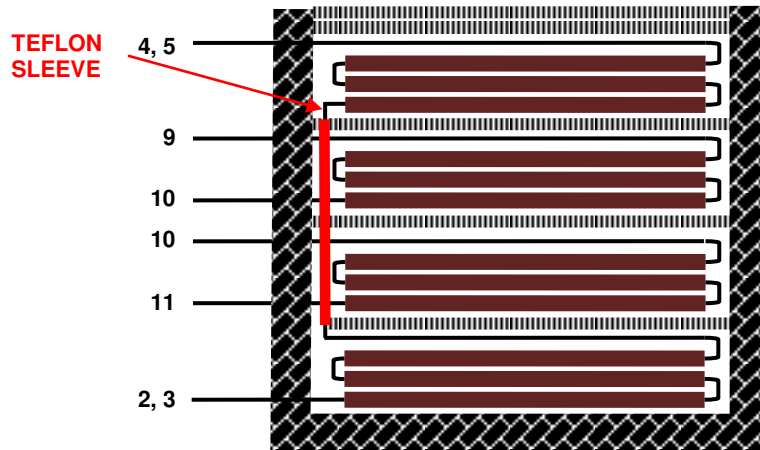

Figure 66 - Transformer construction diagram

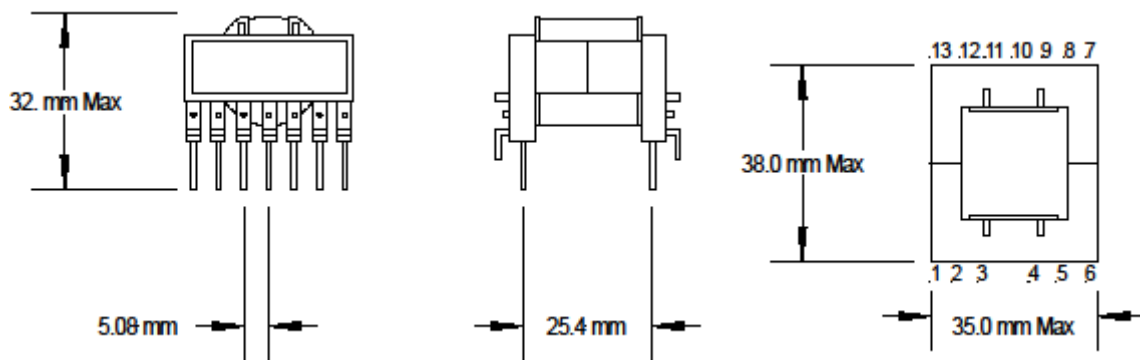

Figure 67 - Transformer Bobbin diagram

APPENDIX VI - OUTPUT INDUCTOR SPECIFICATION

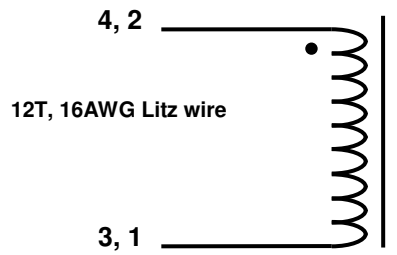

Figure 68 - Output inductor electrical diagram

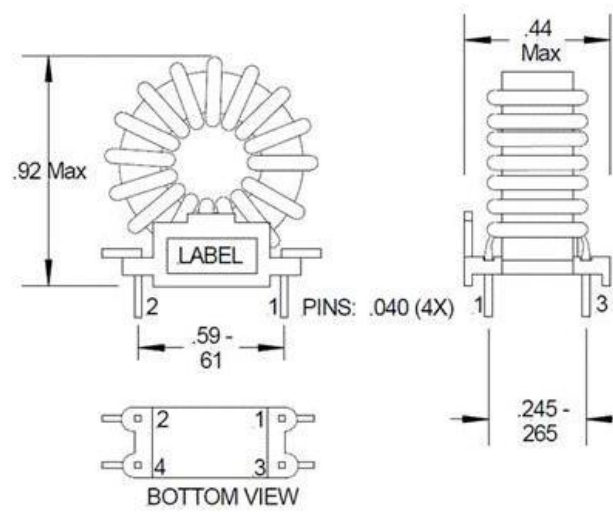

Figure 69 - Output inductor construction diagram

APPENDIX VII - THERMAL PERFORMANCE

All thermal tests were conducted at room temperature with no air flow at 36VDC input voltage and a load of 8A. A pre-soaking time of one hour was before collecting any data with a type K thermocouple for temperature measurement.

Component	Measured temperature at	Estimated temperature at
	27°C	65 °C
Bulk capacitor (C2, C14)	30	68
MOSFET (QA)	40	78
MOSFET (QB)	41	79
MOSFET (QC)	42	80
MOSFET (QD)	40	78
Current sense Transformer (T4)	31	69
Main transformer (T2)	75	113
Icoupler (U14, U15)	50	88
Synchronous Rectifier (SR2)	60	98
Synchronous Rectifier (SR3)	65	103
Output Inductor (L1)	57	95
Output capacitor (C4)	52	90
ADP1043A	35	73
OrFET (Q1)	52	90
R _{SENSE} (R17)	62	100
Buffer Transistor (Q5 to Q12)	42	80

Table 7 - Measured and estimated temperatures at room (27°C) and 65°C

APPENDIX VIII – STEADY STATE WAVEFORMS

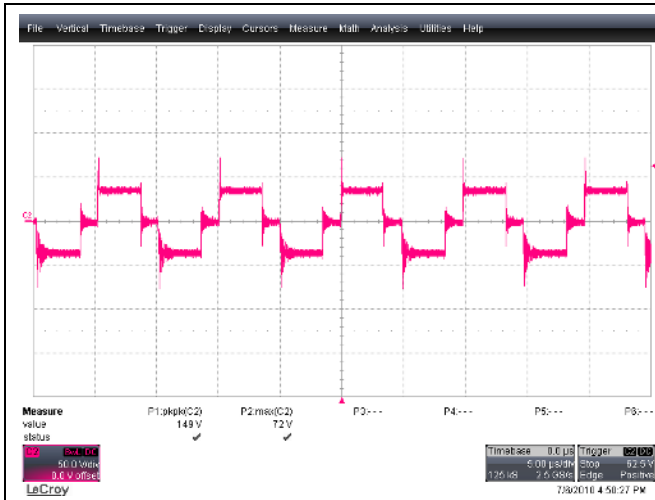

Figure 70 - Voltage across transformer primary, 36VDC, 8A load 50V/div, 5us/div

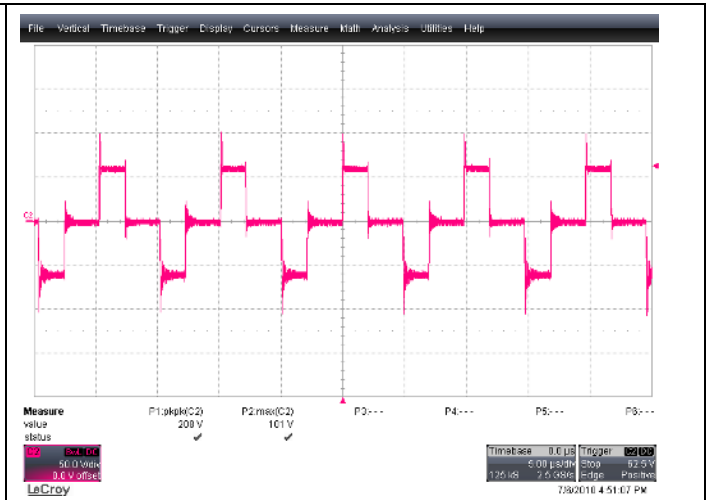

Figure 71 - Voltage across transformer primary, 60VDC, 8A load, 50V/div, 5us/div

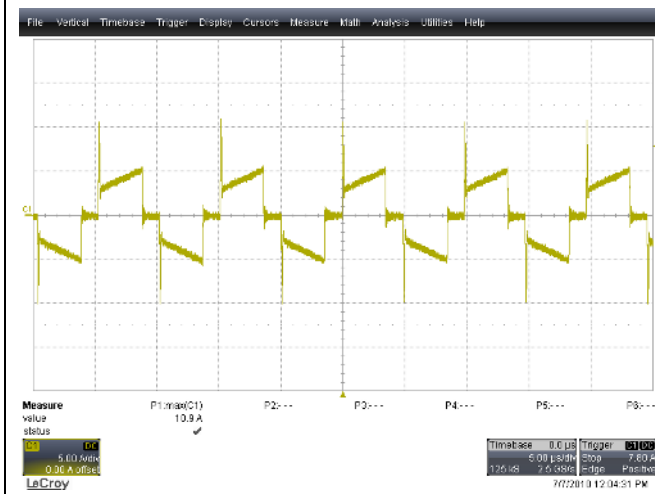

Figure 72 - Primary current at 36VDC, 8A load, 5A/div, 5us/div

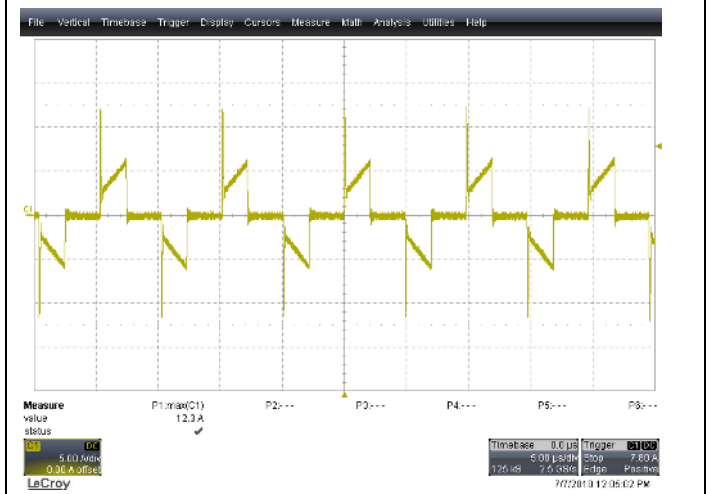
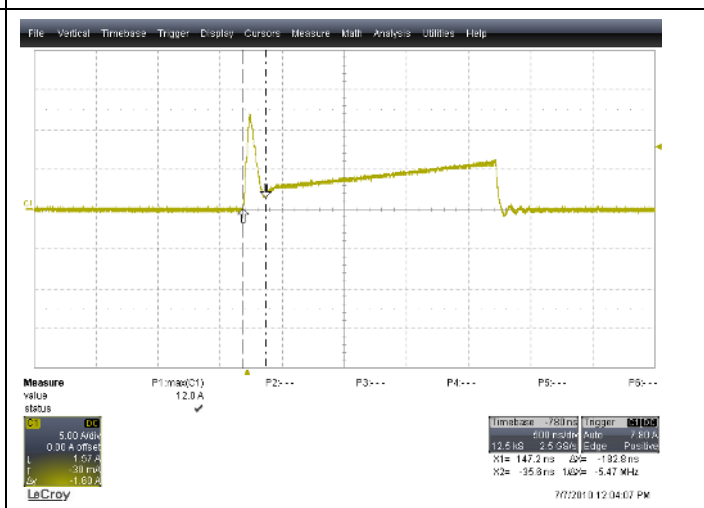
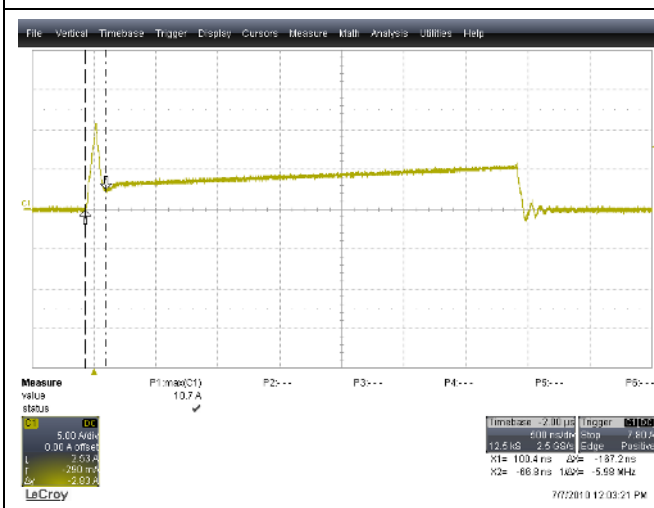
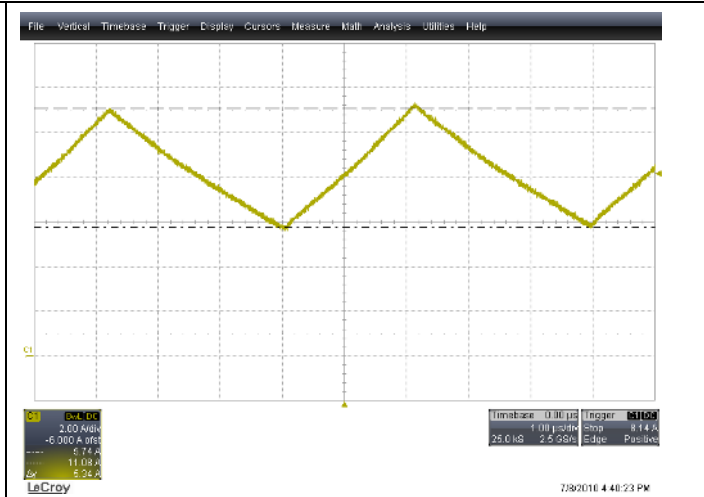
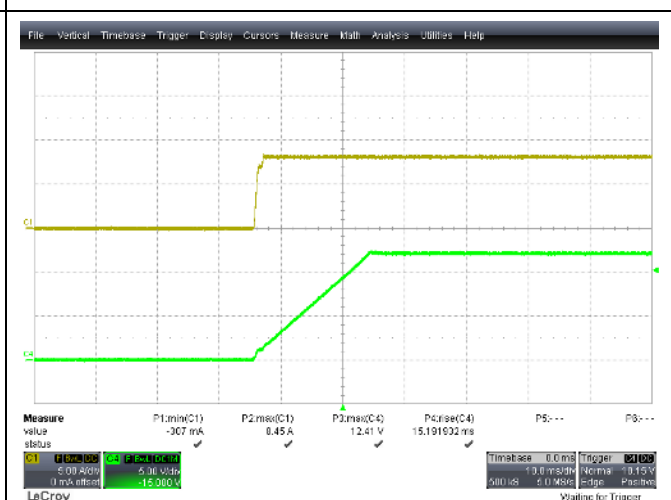
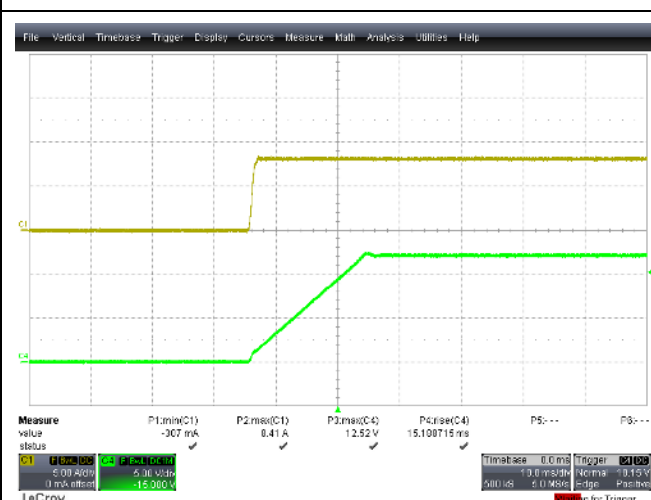
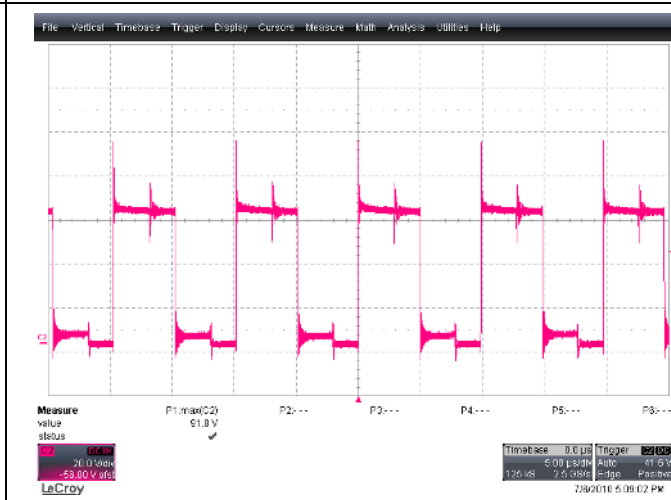
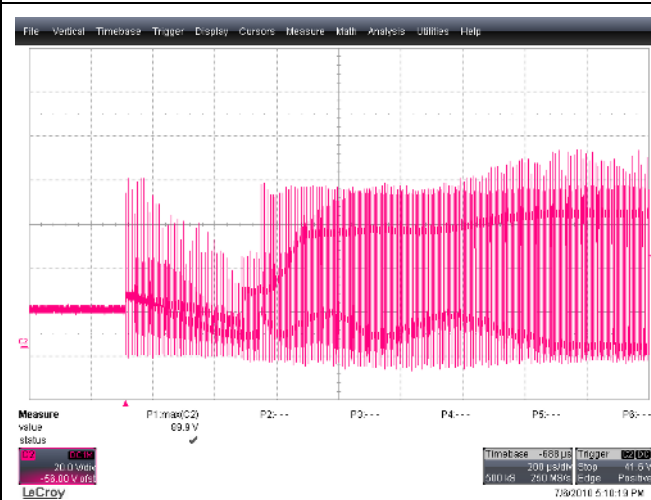
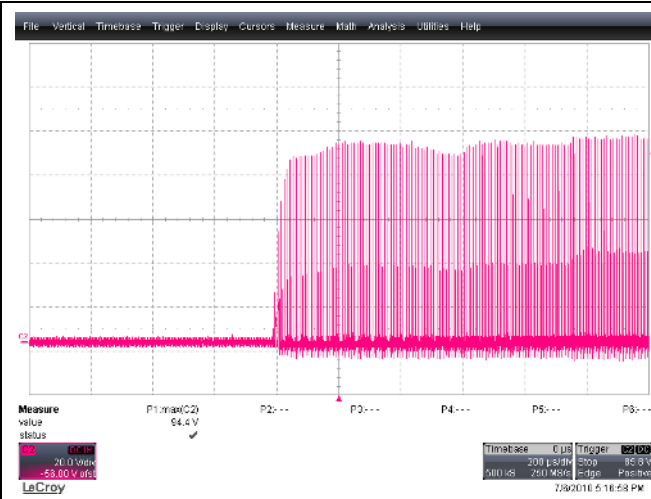

Figure 73 - Primary current at 48VDC, 8A load, 5A/div, 5us/div





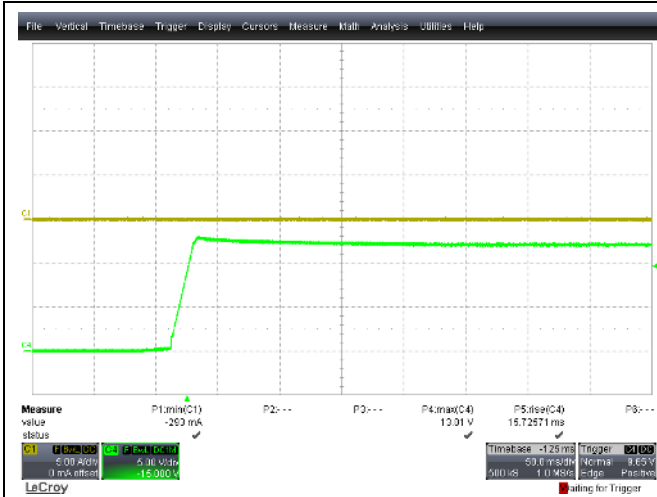

Figure 86 - Output Voltage Startup Profile, 36VDC, 0A
 Upper trace: Output current, 5A/div, 10ms/div
 Bottom trace: Output voltage, 5V/div, 10ms/div

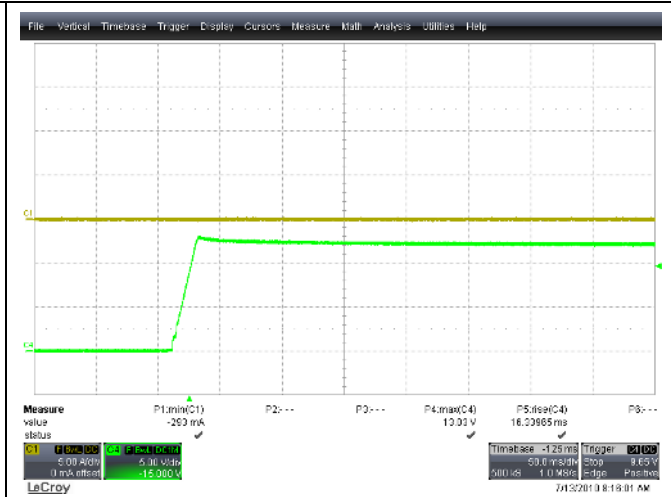

Figure 87 - Output Voltage Startup Profile, 60VDC, 0A
 Upper trace: Output current, 5A/div, 10ms/div
 Bottom trace: Output voltage, 5V/div, 10ms/div

APPENDIX IX – EFFICIENCY AND VOLTAGE REGULATION

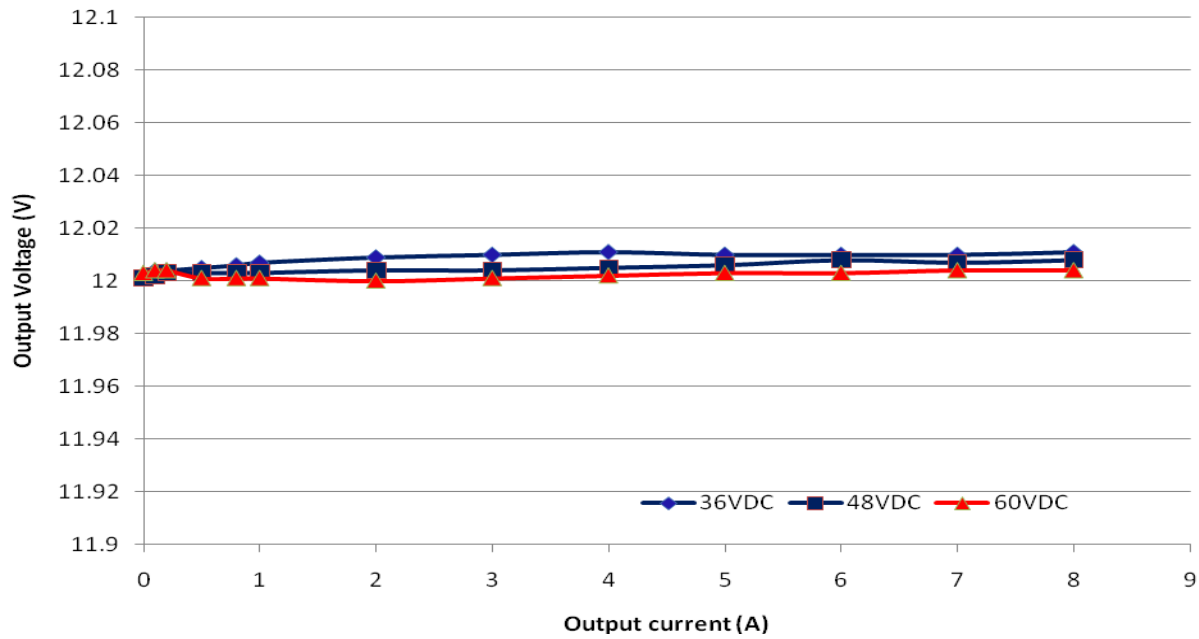

Figure 88 - Output voltage regulation vs load current

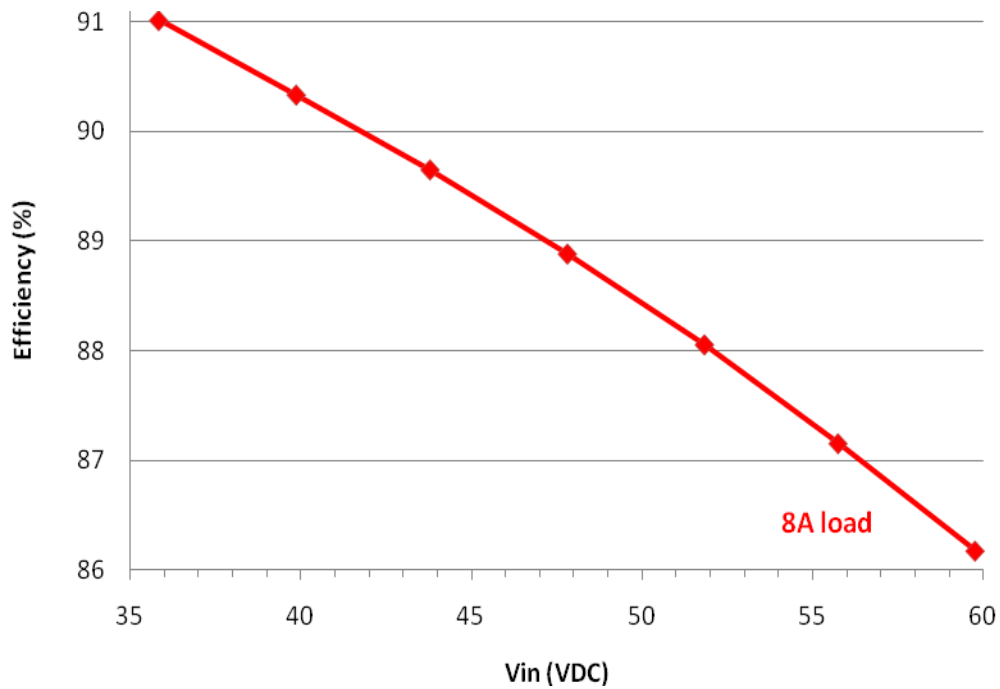

Figure 89 - Efficiency (8A load) vs Input voltage

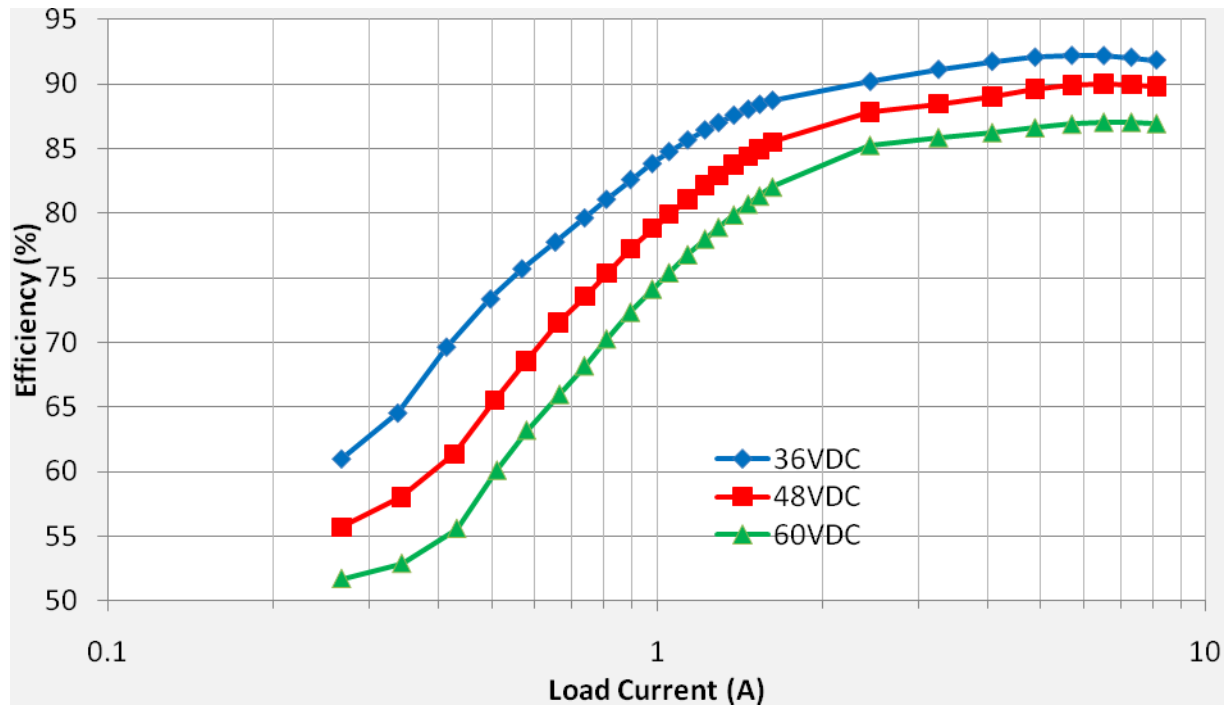

Figure 90 - Load current vs efficiency

APPENDIX X – BILL OF MATERIALS (MAIN BOARD)

Part Ref	Part Description	Package	Manufacturer	Mfg Part No
C2	CAP 330UF 100V +/-20% ELECTROLYTIC ALUM	18X16.5	Panasonic	EEV-FK2A331M
C3	CAP CER 100nF 50V 10% X7R	0805	Murata	GRM21BR71H104KA01L
C4	CAP 1500UF 16V ELECT FK SMD	10X1.5	Panasonic	EEV-FK1C152Q
C5	CAP CER 2700PF 100V +/-10% X7R	1206	AVX	12061C272KAT2A
C6	CAP CER 1UF 25V +/-10% X7R	0805	Murata	GCM21BR71E105KA56L
C7	CAP 1500UF 16V ELECT FK SMD	10X1.5	Panasonic	EEV-FK1C152Q
C8	CAP CER 1UF 25V +/-10% X7R	0805	Murata	GCM21BR71E105KA56L
C9	DNI			
C10	JUMPER WIRE			
C11	DNI			
C12	CAP CER 2700PF 100V +/-10% X7R	1206	AVX	12061C272KAT2A
C13	CAP CERAMIC 10UF 25V +/-20% X5R	1210	Panasonic	ECJ-4YB1E106M
C14	CAP 330UF 100V +/-20% ELECTROLYTIC ALUM	18X16.5	Murata	GRM21BR71H104KA01L
C15	CAP CERAMIC 10UF 25V +/-20% X5R	1210	Panasonic	ECJ-4YB1E106M
C16	CAP CER 1000pF 100V +/-10% X7R	0805	AVX	08051C102KAT2A
C17	CAP 22UF 25V HA ELECT SMD	5X5.8	Panasonic	EEV-HA1E220P
C18	DNI			
C19	CAP FILM MKP .015UF 275VAC X2	MKP X2	Vishay	BFC233820153
C20	CAP FILM MKP .015UF 275VAC X2	MKP X2	Vishay	BFC233820153
C21	DNI			
C22	CAP CER 100pF 50V +/-5% NPO	0805	Murata	GRM2165C1H101JA01D
C23	CAP FILM 4.7UF 100V +/-5% METAPOLY	METALPOLY	Panasonic	ECQ-E1475KF
C24	CAP CER 100nF 50V 10% X7R	0805	Murata	GRM21BR71H104KA01L
C25	DNI			
C26	DNI			
C27	CAP CERAMIC 4.7UF 25V +/-10% X5R	1210	Panasonic	ECJ-4YB1E475K
C28	CAP CERAMIC 1UF 50V +/-10% X7R	1210	Murata	GCM21BR71E105KA56L
C29	CAP CERAMIC 1UF 50V +/-10% X7R	1210	Murata	GCM21BR71E105KA56L
C30	CAP CERAMIC 4.7UF 25V +/-10% X5R	1210	Panasonic	ECJ-4YB1E475K
C31	DNI			
C32	CAP CER 390PF 100V +/-5% NPO	0805	Murata	GRM2165C2A391JA01D
C33	CAP CER 33PF 50V +/-5% NPO	0805	Panasonic	ECJ-2VC1H330J
C34	CAP CER 33PF 50V +/-5% NPO	0805	Panasonic	ECJ-2VC1H330J
C35	CAP CER 33PF 50V +/-5% NPO	0805	Panasonic	ECJ-2VC1H330J
C36	CAP CERAMIC 10UF 25V +/-20% X5R	1210	Panasonic	ECJ-4YB1E106M
C37	CAP CER 33PF 50V +/-5% NPO	0805	Panasonic	ECJ-2VC1H330J
C38	CAP CER 0.47UF 25V 10% X7R	0805	TDK	C2012X7R1E474K
C39	CAP CERAMIC 10UF 25V +/-20% X5R	1210	Panasonic	ECJ-4YB1E106M
C40	CAP CER 0.47UF 25V 10% X7R	0805	TDK	C2012X7R1E474K
C41	CAP CER 0.47UF 25V 10% X7R	0805	TDK	C2012X7R1E474K
C42	CAP CERAMIC 10UF 25V +/-20% X5R	1210	Panasonic	ECJ-4YB1E106M
C43	DNI			
C44	CAP CER 100PF 50V +/-5% NPO	0805	Murata	GRM2165C1H101JA01D
C45	CAP CER 33PF 50V +/-5% NPO	0805	Panasonic	ECJ-2VC1H330J
C46	CAP CER 10000pF 50V +/-10% X7R	0805	Murata	GRM216R71H103KA01D
C49	CAP CER 33PF 50V +/-5% NPO	0805	Panasonic	ECJ-2VC1H330J
C62	CAP CER 10000PF 50V 10% X7R	0805	Murata	GRM216R71H103KA01D
C63	CAP CER 10000PF 50V 10% X7R	0805	Murata	GRM216R71H103KA01D
C64	CAP CERAMIC 10UF 25V +/-20% X5R	1210	Panasonic	ECJ-4YB1E106M
C67	CAP CERAMIC 10UF 25V +/-20% X5R	1210	Panasonic	ECJ-4YB1E106M
C68	DNI			
C69	CAP CER 10000PF 50V 10% X7R	0805		
C70	CAP CER 0.47uF 25V 10% X7R	0805	TDK	C2012X7R1E474K
C71	CAP CER 0.47uF 25V 10% X7R	0805	TDK	C2012X7R1E474K
C72	CAP CER 0.47uF 25V 10% X7R	0805	TDK	C2012X7R1E474K
D1	LED SUPER RED CLEAR 75MA 1.7V SMD	1206	Chicago miniature lighting	CMD15-21SRC/TR8
D2	DIODE SWITCHING 80V 200mA	SOT-23	Inferion	BAV70E6327
D3	DIODE ZENER 16V 1W 5%	MSB-403	Diodes Inc	SMAZ16-13-F
D4	DIODE SWITCHING 80V 200mA	SOT-23	Inferion	BAV70E6327

Part Ref	Part Description	Package	Manufacturer	Mfg Part No
D5	DIODE SCHOTTKY 100V 1A	SMB-403	On Semi	MBRS1100T3G
D6	DIODE SCHOTTKY 100V 2A	SMB-403	Vishay	SS2H10-E3/52T
D7	DIODE SCHOTTKY 100V 2A	SMB-403	Vishay	SS2H10-E3/52T
D8	DIODE SWITCHING 80V 200mA	SOT-23	Infenion	BAV70E6327
D9	DNI			
D10	LED GREEN CLEAR 75MA 2.1V SMD	1206	Chicago miniature lighting	CMD15-21VGC/TR8
D11	LED YELLOW CLEAR 75mA 2.0V SMD	1206	Chicago miniature lighting	CMD15-21VYC/TR8
D12	LED SUPER RED CLEAR 75mA 1.7V SMD	1206	Chicago miniature lighting	CMD15-21SRC/TR8
D13	LED SUPER RED CLEAR 75mA 1.7V SMD	1206	Chicago miniature lighting	CMD15-21SRC/TR8
D14	DNI			
D15	DIODE SWITCHING 80V 200mA	SOT-23	Infenion	BAV70E6327
D16	DIODE SWITCHING 80V 200mA	SOT-23	Infenion	BAV70E6327
D17	DIODE SWITCHING 80V 200mA	SOT-23	Infenion	BAV70E6327
D18	DIODE SWITCHING 80V 200mA	SOT-23	Infenion	BAV70E6327
D19	DIODE SWITCHING 80V 200mA	SOT-23	Infenion	BAV70E6327
D20	DIODE SWITCHING 70V 200mA	SOT-23	Infenion	BAV70E6327
D21	DIODE SWITCHING 80V 200mA	SOT-23	Infenion	BAV70E6327
D22	DIODE SWITCHING 80V 200mA	SOT-23	Infenion	BAV70E6327
F1	FUSE FAST-ACT 1.00A 250V UL TR5	TR5	Littlefuse	37311000410
J1	CONN RECEPT 30POS .100 VERT DUAL	F-Socket-Dual	Tyco Electronics	1-534206-5
J2	CONN JACK BANANA UNINS PANEL MOU		Emerson	108-0740-001
J3	CONN JACK BANANA UNINS PANEL MOU		Emerson	108-0740-001
J4	CONN JACK BANANA UNINS PANEL MOU		Emerson	108-0740-001
J5	CONN JACK BANANA UNINS PANEL MOU		Emerson	108-0740-001
J8	CONN HDR 4POS SGL PCB 30GOLD	Header Male	FCI	69167-104HLF
J9	CONN HEADER 4POS SGL PCB 30GOLD	Header Male	FCI	69167-104HLF
J10	CONN JACK BANANA UNINS PANEL MOU		Emerson	108-0740-001
J11	CONN HEADER BRKWAY .100 02POS STR	Header	Tyco Electronics	4-102973-0-01
J12	CONN HEADER BRKWAY .100 02POS STR	Header	Tyco Electronics	4-102973-0-01
J13	CONN HEADER BRKWAY .100 02POS STR	Header	Tyco Electronics	4-102973-0-01
J14	CONN HEADER BRKWAY .100 02POS STR	Header	Tyco Electronics	4-102973-0-01
J15	CONN HEADER BRKWAY .100 02POS STR	Header	Tyco Electronics	4-102973-0-01
J16	CONN HEADER BRKWAY .100 02POS STR	Header	Tyco Electronics	4-102973-0-01
J17	CONN HEADER BRKWAY .100 02POS STR	Header	Tyco Electronics	4-102973-0-01
J18	CONN HEADER BRKWAY .100 02POS STR	Header	Tyco Electronics	4-102973-0-01
J19	CONN HEADER BRKWAY .100 02POS STR	Header	Tyco Electronics	4-102973-0-01
J20	CONN HEADER BRKWAY .100 02POS STR	Header	Tyco Electronics	4-102973-0-01
L1	INDUCTOR 10UH		Precision Inc.	019-6329-00R
L3	JUMPER WIRE			
QA	MOSFET N-CH 100V 44A	DPAK	Fairchild Semi	FDD3672
QB	MOSFET N-CH 100V 44A	DPAK	Fairchild Semi	FDD3672
QC	MOSFET N-CH 100V 44A	DPAK	Fairchild Semi	FDD3672
QD	MOSFET N-CH 100V 44A	DPAK	Fairchild Semi	FDD3672
Q1	MOSFET N-CH 75V 62A	D2PACK	International Rectifier	IRF2807STRLPBF
Q2	MOSFET N-CH 75V 62A	D2PACK	International Rectifier	IRF2807STRLPBF
Q3	MOSFET N-CH 75V 80A	D2PACK	International Rectifier	IRF2807STRLPBF
Q4	TRANS HIGH POWER NPN 30V 1A	SOT-23	Zetex	FMMT489TA
Q5	TRANS HIGH POWER NPN 30V 1A	SOT-23	Zetex	FMMT489TA
Q6	TRANS HP PNP 30V 1A	SOT-23	Zetex	FMMT589TA
Q7	TRANS HIGH POWER NPN 30V 1A	SOT-23	Zetex	FMMT489TA
Q8	TRANS HP PNP 30V 1A	SOT-23	Zetex	FMMT589TA
Q9	TRANS HIGH POWER NPN 30V 1A	SOT-23	Zetex	FMMT489TA
Q10	TRANS HP PNP 30V 1A	SOT-23	Zetex	FMMT589TA
Q11	TRANS HIGH POWER NPN 30V 1A	SOT-23	Zetex	FMMT489TA
Q12	TRANS HP PNP 30V 1A	SOT-23	Zetex	FMMT589TA
Q13	TRANS HIGH POWER NPN 30V 1A	SOT-23	Zetex	FMMT489TA
RT1	THERMISTOR 100K OHM NTC 0805	RNTC-0805	Murata	NCP21WF104J03RA
R3	RES 24.9K OHM 1/3W 1% SMD	1210	Vishay	CRCW121024K9PFKEA
R4	RES 470 OHM 1/8W 1% SMD	0805	Any	
R5	JUMPER WIRE			
R9	RES 4.70 OHM 1/8W 1% SMD	0805	Any	
R10	RES 10 OHM 1/8W 1% SMD	0805	Any	
R11	RES 4.70 OHM 1/8W 1% SMD	0805	Any	
R13	RES 0.0 OHM 1/8W 5% SMD	0805	Any	
R14	RES 13.0 OHM 1W 1% SMD	2512	Any	
R15	RES 13.0 OHM 1W 1% SMD	2512	Any	
R16	RES 0.0 OHM 1/8W 5% SMD	0805	Any	

Part Ref	Part Description	Package	Manufacturer	Mfg Part No
R17	RES CURRENT SENSE 0.01 OHM 1W 0.5% SMD	2512	Any	
R18	RES 0.0 OHM 1/8W 5% SMD	0805	Any	
R19	DNI			
R20	DNI			
R23	RES 10.0K OHM 1/8W 1% SMD	0805	Any	
R24	RES 2.20K OHM 1/8W 1% SMD	0805	Any	
R25	DNI			
R32	RES 10.0 OHM 1/8W 1% SMD	0805	Any	
R34	RES 1.0 OHM 1/8W 1% SMD	0805	Any	
R35	RES 8.06K OHM 1/8W 1% SMD	0805	Any	
R36	RES 2.05K OHM 1/8W 1% SMD	0805	Any	
R37	RES 1.0 OHM 1/8W 1% SMD	0805	Any	
R38	RES 10.0 OHM 1/8W 1% SMD	0805	Any	
R39	RES 10.0 OHM 1/8W 1% SMD	0805	Any	
R40	RES 8.06K OHM 1/8W 1% SMD	0805	Any	
R41	RES 10.0K OHM 1/8W 1% SMD	0805	Any	
R42	RES 2.05K OHM 1/8W 1% SMD	0805	Any	
R43	RES 10.0 OHM 1/8W 1% SMD	0805	Any	
R44	RES 10.0 OHM 1/8W 1% SMD	0805	Any	
R45	RES 10.0K OHM 1/8W 1% SMD	0805	Any	
R46	RES 1.0 OHM 1/8W 1% SMD	0805	Any	
R47	RES 1.00K OHM 1/8W 1% SMD	0805	Any	
R48	RES 4.7M OHM 1/8W 5% SMD	0805	Any	
R49	RES 10.0K OHM 1/8W 1% SMD	0805	Any	
R50	RES 10.0K OHM 1/8W 1% SMD	0805	Any	
R51	RES 10.0K OHM 1/8W 1% SMD	0805	Any	
R52	RES 10.0K OHM 1/8W 1% SMD	0805	Any	
R53	RES 2.20K OHM 1/8W 1% SMD	0805	Any	
R54	RES 2.20K OHM 1/8W 1% SMD	0805	Any	
R55	RES 0.0 OHM 1/2W 5% SMD	2010	Any	
R56	RES 0.0 OHM 1/8W 5% SMD	0805	Any	
R57	RES 10.0K OHM 1/8W 1% SMD	0805	Any	
R58	RES 15.0K OHM 1/8W 1% SMD	0805	Any	
R59	RES 100K OHM 1/8W 1% SMD	0805	Any	
R60	RES 100 OHM 1/8W 1% SMD	0805	Any	
R61	RES 100 OHM 1/8W 1% SMD	0805	Any	
R62	RES 2.20K OHM 1/8W 1% SMD	0805	Any	
R63	RES 2.20K OHM 1/8W 1% SMD	0805	Any	
R64	RES 100 OHM 1/8W 1% SMD	0805	Any	
R66	RES 1.00K OHM 1/8W 1% SMD	0805	Any	
R67	RES 1.00K OHM 1/8W 1% SMD	0805	Any	
R68	RES 470 OHM 1/8W 1% SMD	0805	Any	
R70	RES 2.20K OHM 1/8W 1% SMD	0805	Any	
R71	RES 0.0 OHM 1/2W 5% SMD	2010	Any	
R72	RES 10.0 OHM 1/8W 1% SMD	0805	Any	
R73	RES 10.0 OHM 1/8W 1% SMD	0805	Any	
R74	RES 10.0K OHM 1/8W 1% SMD	0805	Any	
R75	RES 10.0 OHM 1/8W 1% SMD	0805	Any	
R76	RES 10.0K OHM 1/8W 1% SMD	0805	Any	
R77	RES 10.0K OHM 1/8W 1% SMD	0805	Any	
R78	RES 1.00K OHM 1/8W 1% SMD	0805	Any	
R79	RES 10.0 OHM 1/8W 1% SMD	0805	Any	
R80	RES 100 OHM 1/8W 1% SMD	0805	Any	
R81	RES 10.0 OHM 1/8W 1% SMD	0805	Any	
SW1	SW SLIDE SPDT 30V 0.2A PC MNT	SLIDE-SW	Keystone Electronics	5010
TP1-64	TEST POINT PC MULTIPURPOSE RED	TP-063	Keystone Electronics	5010
T2	Transformer	ETD29	Precision Inc	019-6330-00R
T4	SMT CURRENT SENSE TRANSFORMERS 500kHz 15A	PE-68280	Pulse	PE-68280
U1	IC MOSFET DRVR DUAL HS 4A	8-SOIC	Analog Devices	ADP3624
U7A	DNI	8-SOIC	Analog Devices	OP297FSZ
U14	ISOLATED 2CH HALF-BRIDGE DRIVER	SOIC-W-16	Analog Devices	ADUM5230
U15	ISOLATED 2CH HALF-BRIDGE DRIVER	SOIC-W-16	Analog Devices	ADUM5230

APPENDIX XI – BILL OF MATERIALS (DAUGHTER CARD)

Part Ref	Part Description	Package	Manufacturer	Mfg Part No
C1	DNI		Murata	GRM32RR71H105KA01L
C2	DNI			
C3	DNI			
C4	DNI			
C5	CAPACITOR CERAMIC 1.0UF 50V 10% X7R	1210	Murata	GRM32RR71H105KA01L
C6	CAPACITOR CERAMIC 0.1UF 10% 50V X7R	0805	AVX	08055C104KAT2A
C7	DNI			
C8	CAPACITOR CERAMIC 0.1UF 10% 50V X7R	0805	AVX	08055C104KAT2A
C9	DNI			
C10	DNI			
C11	CAPACITOR CERAMIC 0.1UF 10% 50V X7R	0805	AVX	08055C104KAT2A
C12	CAPACITOR CERAMIC 0.47UF 5% 17V X7R	0805	AVX	0805YC474JAT2A
C13	DNI			
C14	CAPACITOR CERAMIC 0.01UF 10% 100V X7R	0805	AVX	08051C103KAT2A
C15	CAPACITOR CERAMIC 1000pF 10% 100V X7R	0603	Murata	GRM188R72A102KA01D
J1	CONNETOR HEADER FEMALE 30PS .1" DL TIN	Fmal Socket	Sullins Connector	PPTC152LFBN-RC
J7	CONNECTOR HEADER 4POS SGL PCB 30 GOLD	Header-4POS	Solutions	69167-104HLF
R1	RESISTOR 27.0K OHM 1/8W 1% SMD	0805	FCI	
R2	RESISTOR 1.00K OHM 1/8W 1% SMD	0805	Any	
R3	RESISTOR 10.0K OHM 1/10W .1% +/-25ppm SMD	0805	Any	
R4	RESISTOR 10.0K OHM 1/10W .1% +/-25ppm SMD	0805	Any	
R5	RESISTOR 11.0K OHM 1/10W .1% +/-25ppm SMD	0805	Any	
R6	RESISTOR 1.00K OHM 1/10W .1% +/-25ppm SMD	0805	Any	
R7	RESISTOR 11.0K OHM 1/10W .1% +/-25ppm SMD	0805	Any	
R8	RESISTOR 1.00K OHM 1/10W .1% +/-25ppm SMD	0805	Any	
R10	RESISTOR 11.0K OHM 1/10W .1% +/-25ppm SMD	0805	Any	
R11	RESISTOR 1.00K OHM 1/10W .1% +/-25ppm SMD	0805	Any	
R12	RESISTOR 0.0 OHM 1/8W 5% SMD	0805	Any	
R13	RESISTOR 0.0 OHM 1/8W 5% SMD	0805	Any	
R14	RESISTOR 1.00K OHM 1/8W 1% SMD	0805	Any	
R15	RESISTOR 1.00K OHM 1/8W 1% SMD	0805	Any	
R16	RESISTOR 0.0 OHM 1/8W 5% SMD	0805	Any	
R17	RESISTOR 0.0 OHM 1/8W 5% SMD	0805	Any	
R18	DNI			
R19	RESISTOR 10.0K OHM 1/8W 1% SMD	0805	Any	
R20	RESISTOR 49.9K OHM 1/8W 1% SMD	0805	Any	
R24	RESISTOR 2.20K OHM 1/8W 1% SMD	0805	Any	
R29	RESISTOR 2.20K OHM 1/8W 1% SMD	0805	Any	
R32	DNI			
R33	DNI			
U1	I.C. Secondary Side Power Supply Controller	LFCSP-32	ADP1043A	Analog Devices
U2	I.C. LDO LINEAR REGULATOR 200MA 3.3V	SOIC-8	ADP3303	Analog Devices

APPENDIX XII – REGISTER FILE (ADP1043AFB100_I_0710.43R)

Reg(0h) = 0h - Fault Register 1	Reg(2Ah) = 1Ah - Share Bus Setting
Reg(1h) = 0h - Fault Register 2	Reg(2Bh) = 4h - Temperature Trim
Reg(2h) = 0h - Fault Register 3	Reg(2Ch) = E2h - PSON/Soft Start Setting
Reg(3h) = 0h - Fault Register 4	Reg(2Dh) = 58h - Pin Polarity Setting
Reg(4h) = 10h - Latched Fault Register 1	Reg(2Eh) = B4h - Modulation Limit
Reg(5h) = 0h - Latched Fault Register 2	Reg(2Fh) = 1Bh - OTP Threshold
Reg(6h) = 1h - Latched Fault Register 3	Reg(30h) = 5Eh - OrFET
Reg(7h) = 1h - Latched Fault Register 4	Reg(31h) = A5h - VS3 Voltage Setting
Reg(8h) = 3h - Fault Configuration Register 1	Reg(32h) = 51h - VS1 Overvoltage Limit
Reg(9h) = 3Ah - Fault Configuration Register 2	Reg(33h) = 11h - VS3 Overvoltage Limit
Reg(Ah) = 37h - Fault Configuration Register 3	Reg(34h) = 42h - VS1 Undervoltage Limit
Reg(Bh) = 73h - Fault Configuration Register 4	Reg(35h) = FFh - Line Impedance Limit
Reg(Ch) = ACh - Fault Configuration Register 5	Reg(36h) = 7h - Load Line Impedance
Reg(Dh) = 8Ah - Fault Configuration Register 6	Reg(37h) = FFh - Reserved
Reg(Eh) = 65h - Flag Configuration	Reg(38h) = 83h - VS1 Trim
Reg(Fh) = ADh - Soft-Start Flag Blank	Reg(39h) = 1h - VS2 Trim
Reg(10h) = 0h - First Flag ID	Reg(3Ah) = 81h - VS3 Trim
Reg(11h) = FFh - Reserved	Reg(3Bh) = 1h - Light Load Disable Setting
Reg(12h) = EEAh - VS1 Value	Reg(3Ch) = 5h - Silicon Revision ID
Reg(13h) = 356Ch - CS1 Value	Reg(3Dh) = 41h - Manufacturer ID
Reg(14h) = 31C0h - CS1 x VS1 Value	Reg(3Eh) = 43h - Device ID
Reg(15h) = A7D0h - VS1 Voltage Value	Reg(3Fh) = 11h - OUTAUX Switching Frequency Setting
Reg(16h) = A68Ch - VS2 Voltage Value	Reg(40h) = 11h - PWM Switching Frequency Setting
Reg(17h) = A504h - VS3 Voltage Value	Reg(41h) = 40h - PWM 1 Positive Edge Timing
Reg(18h) = B408h - CS2 Value	Reg(42h) = 80h - PWM 1 Positive Edge Setting
Reg(19h) = 7404h - CS2 x VS3 Value	Reg(43h) = 5Fh - PWM 1 Negative Edge Timing
Reg(1Ah) = 3720h - RTD Temperature Value	Reg(44h) = 98h - PWM 1 Negative Edge Setting
Reg(1Bh) = FFh - Reserved	Reg(45h) = 2h - PWM 2 Positive Edge Timing
Reg(1Ch) = FFh - Reserved	Reg(46h) = 80h - PWM 2 Positive Edge Setting
Reg(1Dh) = 0h - Share Bus Value	Reg(47h) = 21h - PWM 2 Negative Edge Timing
Reg(1Eh) = B0h - Modulation Value	Reg(48h) = 88h - PWM 2 Negative Edge Setting
Reg(1Fh) = 2h - Line Impedance Value	Reg(49h) = 2h - PWM 3 Positive Edge Timing
Reg(20h) = FFh - Reserved	Reg(4Ah) = 80h - PWM 3 Positive Edge Setting
Reg(21h) = 4Ah - CS1 Gain Trim	Reg(4Bh) = 21h - PWM 3 Negative Edge Timing
Reg(22h) = A8h - CS1 OCP Limit	Reg(4Ch) = 88h - PWM 3 Negative Edge Setting
Reg(23h) = 67h - CS2 Gain Trim	Reg(4Dh) = 40h - PWM 4 Positive Edge Timing
Reg(24h) = 8h - CS2 Offset Trim	Reg(4Eh) = 80h - PWM 4 Positive Edge Setting
Reg(25h) = 2Ah - CS2 Digital Trim	Reg(4Fh) = 5Fh - PWM 4 Negative Edge Timing
Reg(26h) = E1h - CS2 OCP Limit	Reg(50h) = 98h - PWM 4 Negative Edge Setting
Reg(27h) = E7h - CS1 and CS2 OCP Setting	Reg(51h) = 23h - SR 1 Positive Edge Timing
Reg(28h) = 1h - VS Balance Gain Setting	Reg(52h) = 8Ah - SR 1 Positive Edge Setting
Reg(29h) = 2h - Share Bus Bandwidth	Reg(53h) = 0h - SR 1 Negative Edge Timing

Reg(54h) = 3h - SR 1 Negative Edge Setting	Reg(80h) = 35h -
Reg(55h) = 61h - SR 2 Positive Edge Timing	Reg(81h) = 35h -
Reg(56h) = 88h - SR 2 Positive Edge Setting	Reg(82h) = 35h -
Reg(57h) = 3Dh - SR 2 Negative Edge Timing	
Reg(58h) = 50h - SR 2 Negative Edge Setting	
Reg(59h) = 0h - PWM AUX Positive Edge Timing	
Reg(5Ah) = 0h - PWM AUX Positive Edge Setting	
Reg(5Bh) = 8h - PWM AUX Negative Edge Timing	
Reg(5Ch) = 90h - PWM AUX Negative Edge Setting	
Reg(5Dh) = 80h - PWM and SR Pin Disable Setting	
Reg(5Eh) = 0h - Password Lock	
Reg(5Fh) = 3h - Soft-Start Digital Filter LF Gain Setting	
Reg(60h) = 91h - Normal Mode Digital Filter LF Gain Setting	
Reg(61h) = 83h - Normal Mode Digital Filter Zero Setting	
Reg(62h) = 14h - Normal Mode Digital Filter Pole Setting	
Reg(63h) = 5Dh - Normal Mode Digital Filter HF Gain Setting	
Reg(64h) = 1Ah - Light Load Digital Filter LF Gain Setting	
Reg(65h) = 76h - Light Load Digital Filter Zero Setting	
Reg(66h) = Eh - Light Load Digital Filter Pole Setting	
Reg(67h) = 13h - Light Load Digital Filter HF Gain Setting	
Reg(68h) = 0h - Dead Time Threshold	
Reg(69h) = 88h - Dead Time 1	
Reg(6Ah) = 88h - Dead Time 2	
Reg(6Bh) = 88h - Dead Time 3	
Reg(6Ch) = 88h - Dead Time 4	
Reg(6Dh) = 88h - Dead Time 5	
Reg(6Eh) = 88h - Dead Time 6	
Reg(6Fh) = 88h - Dead Time 7	
Reg(70h) = 8h -	
Reg(71h) = 36h -	
Reg(72h) = 54h -	
Reg(73h) = 1Fh -	
Reg(74h) = 0h -	
Reg(75h) = FFh -	
Reg(76h) = FFh -	
Reg(77h) = 0h -	
Reg(78h) = 0h -	
Reg(79h) = 1Fh -	
Reg(7Ah) = 4h -	
Reg(7Bh) = FFh - Factory Default Settings	
Reg(7Ch) = 1h - EEPROM X Address	
Reg(7Dh) = 35h - EEPROM Y Address	
Reg(7Eh) = 35h - EEPROM Register	
Reg(7Fh) = FFh -	

APPENDIX XIII – BOARD FILE (ADP1043AFB100_I_0710.43B)

INPUT VOLTAGE = 48 V

N1 = 6

N2 = 3

R (CS2) = 11 MOHM

I (LOAD) = 8 A

R1 = 11 KOHM

R2 = 1 KOHM

C3 = 1 UF

C4 = 1 UF

N1 (CS1) = 1

N2 (CS1) = 100

R (CS1) = 10 OHM

ESR (L1) = 6 MOHM

L1 = 6.5 UH

C1 = 1500 UF

ESR (C1) = 50 MOHM

ESR (L2) = 40 MOHM

L2 = 0 UH

C2 = 1500 UF

ESR (C2) = 50 MOHM

R (NORMAL-MODE) (LOAD) = 1.5 OHM

R (LIGHT-LOAD-MODE) (LOAD) = 44 OHM

CAP ACROSS R1 & R2 = 0 "(1 = YES: 0 = NO)"

TOPOLOGY = 0 (0 = FULL BRIDGE: 1 = HALF BRIDGE: 2 = TWO SWITCH FORWARD: 3 = INTERLEAVED TWO SWITCH FORWARD: 4 = ACTIVE CLAMP FORWARD: 5 = RESONANT MODE: 6 = CUSTOM)

SWITCHES / DIODES = 0 (0 = SWITCHES: 1 = DIODES)

HIGH SIDE / LOW SIDE SENSE (CS2) = 0 (1 = HIGH-SIDE: 0 = LOW-SIDE SENSE)

SECOND LC STAGE = 1 (1 = YES: 0 = NO)

CS1 INPUT TYPE = 1 (1 = AC: 0 = DC)

R3 = 0 KOHM

R4 = 0 KOHM

PWM MAIN = 0 (0 = OUTA: 1 = OUTB: 2 = OUTC: 3 = OUTD: 4 = SR1: 5 = SR2: 6 = OUTAUX)

C5 = 0 UF

C6 = 0 UF

APPENDIX XIV – CS1 AND CS2 MEASUREMENT VS GUI READING

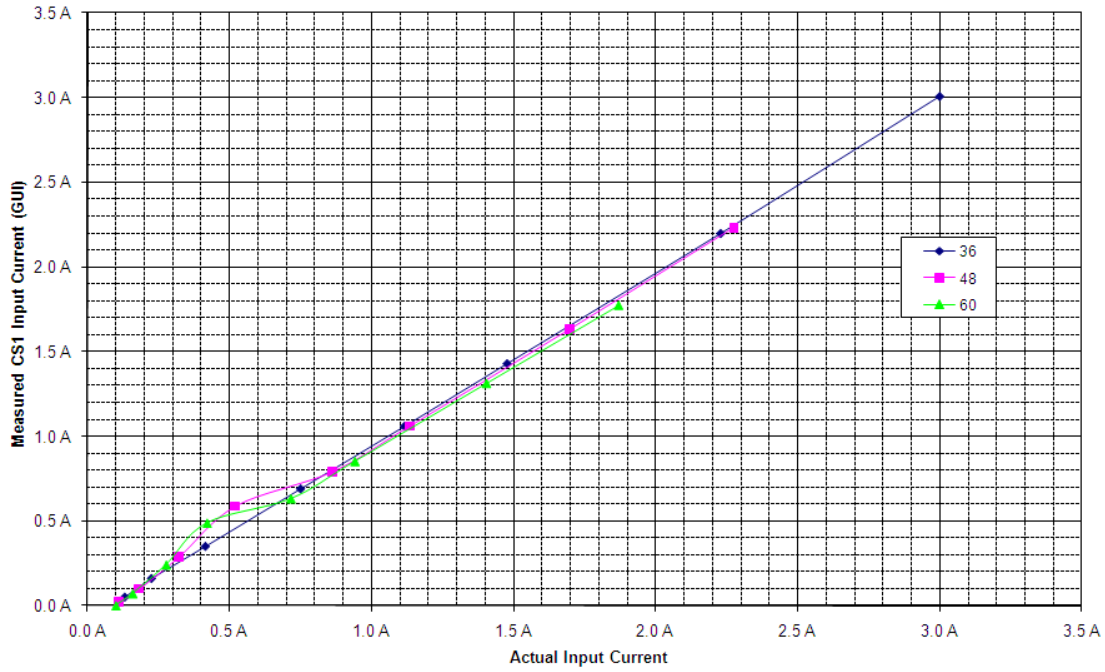

Figure 91 - Input current reading linearity

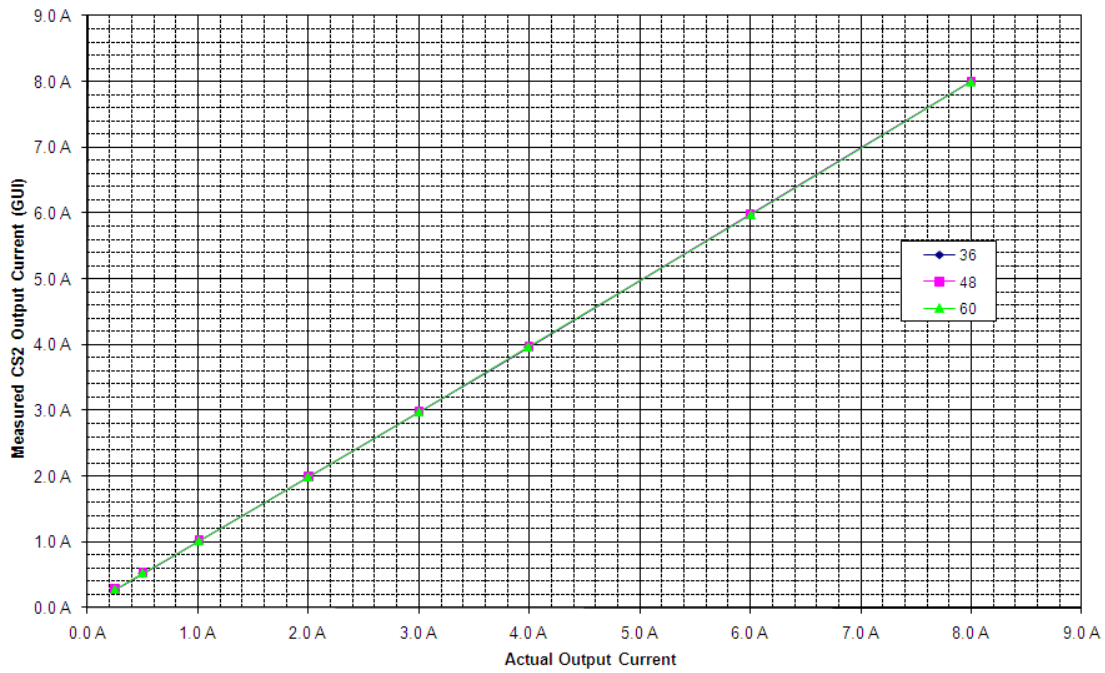

Figure 92 - Output current reading linearity

NOTES