

THIS DRAWING IS UNPUBLISHED. RELEASED FOR PUBLICATION
 © COPYRIGHT - By - ALL RIGHTS RESERVED.

LOC	DIST	REVISIONS					
FT	0	P	LTR	DESCRIPTION	DATE	DWN	APVD
		G2		REVISED PER ECO-11-004820	11MAR11	RK	HMR

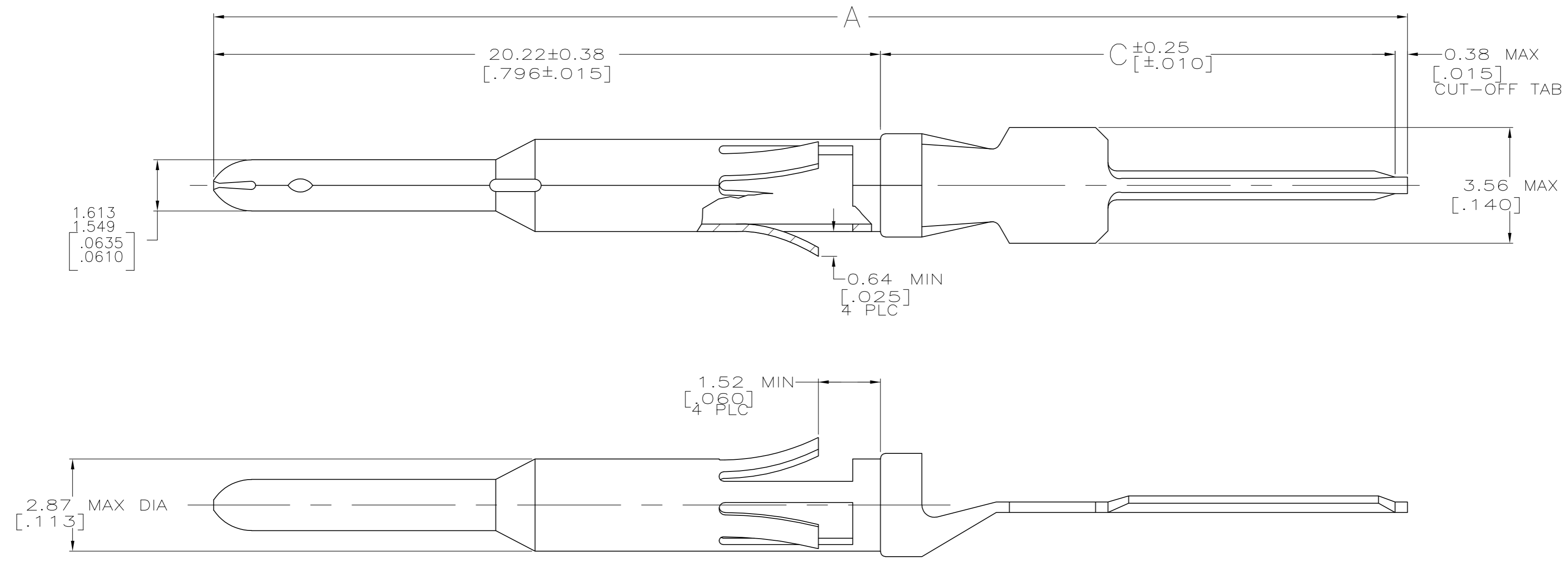

- ⚠ BRASS PER MIL-C-50.
- ⚠ 0.76um [.000030] MIN GOLD FOR A LENGTH OF 3.81 [.150] MIN ON CONTACT END, 1.27um [.000050] MIN TIN-LEAD ON OPPOSITE END, BOTH OVER 1.27um [.000050] MIN NICKEL ON ENTIRE CONTACT.
- 3. GOLD PLATING PER MIL-G-45204; TIN PLATING PER MIL-T-10727; NICKEL PLATING PER QQ-N-290.
- ⚠ 0.76um [.000030] MIN GOLD FOR A LENGTH OF 3.81 [.150] MIN ON CONTACT END, 1.27um [.000050] MIN TIN ON OPPOSITE END, BOTH OVER 1.27um [.000050] MIN NICKEL ON ENTIRE CONTACT.
- ⚠ OBSOLETE PARTS: OBSOLETE CIS STREAMLINING PER D.RENAUD/D.SINISI

⚠ OBSOLETE	25.91 [1.020]	46.51 [1.831]	2-66730-1
⚠ OBSOLETE	21.11 [.831]	41.71 [1.642]	1-66730-9
⚠ OBSOLETE	15.80 [.622]	36.40 [1.433]	1-66730-7
	25.91 [1.020]	46.51 [1.831]	66730-9
	21.11 [.831]	41.71 [1.642]	66730-6
	15.80 [.622]	36.40 [1.433]	66730-3
	C	A	PART NUMBER

THIS DRAWING IS A CONTROLLED DOCUMENT.		DWN	07/09/92	STE TE Connectivity	
		CHK	7-10-92		
DIMENSIONS: mm [INCHES]		TOLERANCES UNLESS OTHERWISE SPECIFIED:		NAME	
		0 PLC	± -	PRODUCT SPEC	
		1 PLC	± -	APPLICATION SPEC	
		2 PLC	± 0.13 [.005]	WEIGHT	
		3 PLC	± -	SCALE	
MATERIAL		4 PLC	± -	SIZE	CAGE CODE
FINISH		ANGLES	± -	A2	00779
		FINISH	± -	DRAWING NO	
				C=66730	
				RESTRICTED TO	
				-	
				SCALE 10:1 SHEET 1 OF 1 REV G2	