

## 3.2 Gbps Precision, 1:2 LVDS Fanout Buffer with Internal Termination and Fail Safe Input

### Features

- Precision 1:2 LVDS Fanout Buffer
- Guaranteed AC Performance Over Temperature and Voltage:
  - DC-to > 3.2 Gbps Throughput
  - <300 ps Propagation Delay (IN-to-Q)
  - <20 ps Within-Device Skew
  - <100 ps Rise/Fall Times
- Fail Safe Input
  - Prevents Outputs From Oscillating When Input Is Invalid
- Ultra-Low Jitter Design
  - 130 fs<sub>RMS</sub> Typical Additive Phase Jitter
  - High-Speed LVDS Outputs
- 2.5V ±5% Power Supply Operation
- Industrial Temperature Range: -40°C to +85°C
- Available In 16-pin (3 mm x 3 mm) QFN Package

### Applications

- All SONET Clock And Data Distribution
- Fibre Channel Clock And Data Distribution
- Gigabit Ethernet Clock And Data Distribution
- Backplane Distribution

### Markets

- DataCom
- Telecom
- Storage
- ATE
- Test and Measurement

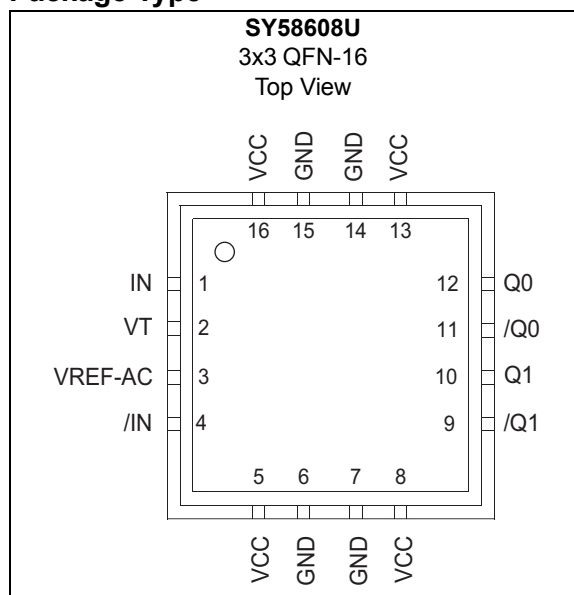
### General Description

The SY58608U is a 2.5V, high-speed, fully differential 1:2 LVDS fanout buffer optimized to provide two identical output copies with less than 20 ps of skew and 130 fs<sub>RMS</sub> typical additive phase jitter. The SY58608U can process clock signals as fast as 2 GHz or data patterns up to 3.2 Gbps.

The differential input includes Microchip's unique, 3-pin input termination architecture that interfaces to LVPECL, LVDS or CML differential signals, (AC- or DC-coupled) as small as 100 mV (200 mV<sub>PP</sub>) without any level-shifting or termination resistor networks in the signal path. For AC-coupled input interface applications, an integrated voltage reference (V<sub>REF-AC</sub>) is provided to bias the V<sub>T</sub> pin. The outputs are 325 mV LVDS, with rise/fall times guaranteed to be less than 100 ps.

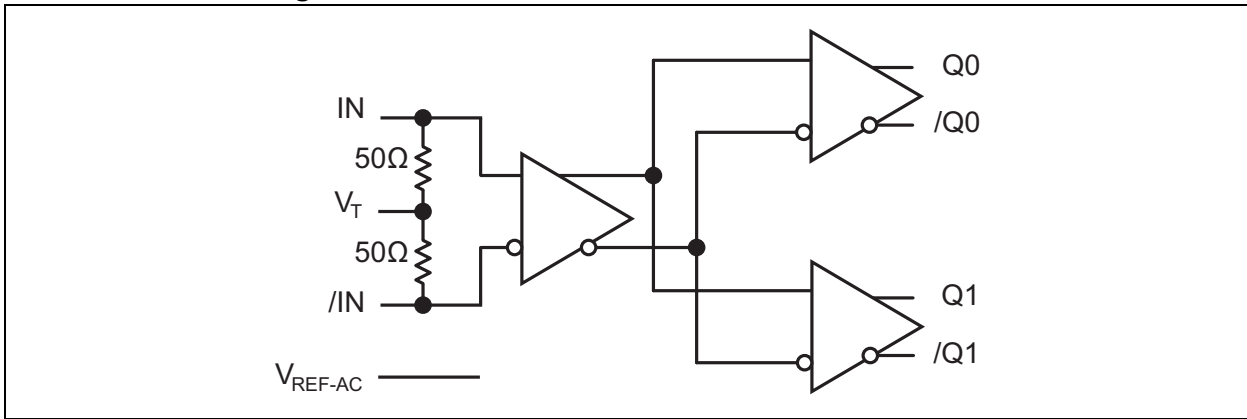
The SY58608U operates from a 2.5V ±5% supply and is guaranteed over the full industrial temperature range (-40°C to +85°C). The SY58608U is part of Microchip's high-speed, Precision Edge<sup>®</sup> product line.

### Package Type



# SY58608U

## Functional Block Diagram



## 1.0 ELECTRICAL CHARACTERISTICS

### Absolute Maximum Ratings †

Supply Voltage, $V_{CC}$ .....	-0.5V to +4.0V
Input Voltage, $V_{IN}$ .....	-0.5V to $V_{CC} + 0.3V$
LVDS Output Current, $I_{OUT}$ .....	$\pm 10$ mA
Input Current	
Source or Sink Current on, $I_N$ , $/I_N$ .....	$\pm 50$ mA
Current, $V_{REF}$	
Source or Sink Current on $V_{REF-AC}$ (Note 1).....	$\pm 1.5$ mA

### Operating Ratings ††

Supply Voltage, $V_{IN}$ .....	+2.375V to +2.625V
--------------------------------	--------------------

† **Notice:** Permanent device damage may occur if absolute maximum ratings are exceeded. This is a stress rating only and functional operation is not implied at conditions other than those detailed in the operational sections of this data sheet. Exposure to absolute maximum ratings conditions for extended periods may affect device reliability.

†† **Notice:** The data sheet limits are not guaranteed if the device is operated beyond the operating ratings.

**Note 1:** Due to the limited drive capability, use for input of the same package only.

### DC CHARACTERISTICS (Note 1)

Electrical Characteristics: $T_A = -40^\circ\text{C}$ to $+85^\circ\text{C}$ , Unless otherwise stated.						
Parameters	Sym.	Min.	Typ.	Max.	Units	Conditions
Power Supply Voltage Range	$V_{CC}$	2.375	2.5	2.625	V	—
Power Supply Current	$I_{CC}$	—	55	75	mA	No load, max. $V_{CC}$
Differential Input Resistance (IN-to- $/I_N$ )	$R_{DIFF\_IN}$	90	100	110	$\Omega$	—
Input HIGH Voltage (IN, $/I_N$ )	$V_{IH}$	1.2	—	$V_{CC}$	V	IN, $/I_N$
Input LOW Voltage (IN, $/I_N$ )	$V_{IL}$	0	—	$V_{IH}-0.1$	V	IN, $/I_N$
Input Voltage Swing (IN, $/I_N$ )	$V_{IN}$	0.1	—	1.7	V	See Figure 6-2, (Note 2)
Differential Input Voltage Swing ( $ I_N - /I_N $ )	$V_{DIFF\_IN}$	0.2	—	—	V	See Figure 6-4
Input Voltage Threshold that Triggers FSI	$V_{IN\_FSI}$	—	30	100	mV	—
Output Reference Voltage	$V_{REF-AC}$	$V_{CC} - 1.3$	$V_{CC} - 1.2$	$V_{CC} - 1.1$	V	—
Voltage from Input to $V_T$	IN to $V_T$	—	—	1.28	V	—

**Note 1:** The circuit is designed to meet the DC specifications shown in the above table after thermal equilibrium has been established.

**2:**  $V_{IN}$  (max) is specified when  $V_T$  is floating.

# SY58608U

## LVDS OUTPUTS DC ELECTRICAL CHARACTERISTICS (Note 1)

**Electrical Characteristics:**  $V_{CC} = +2.5V \pm 5\%$ ,  $R_L = 100\Omega$  across the output pairs;  $T_A = -40^\circ C$  to  $+85^\circ C$ , Unless otherwise stated.

Parameter	Symbol	Min.	Typ.	Max.	Units	Condition
Output Voltage Swing	$V_{OUT}$	250	325	—	mV	See Figure 6-2, 6-3.
Differential Output Voltage Swing	$V_{DIFF\_OUT}$	500	650	—	mV	See Figure 6-4.
Output Common Mode Voltage	$V_{OCM}$	1.125	1.20	1.275	V	See Figure 6-5.
Change in Common Mode Voltage	$\Delta V_{OCM}$	-50	—	50	mV	See Figure 6-5.

**Note 1:** The circuit is designed to meet the DC specifications shown in the above table after thermal equilibrium has been established.

## AC ELECTRICAL CHARACTERISTICS (Note 1)

**Electrical Characteristics:**  $V_{CC} = +2.5V \pm 5\%$ ,  $R_L = 100\Omega$  across the output pairs; Input  $t_r/t_f \leq 300$  ps;  $T_A = -40^\circ C$  to  $+85^\circ C$ , Unless otherwise stated.

Parameter	Symbol	Min.	Typ.	Max.	Units	Condition
Maximum Frequency	$f_{MAX}$	3.2	4.25	—	Gbps	NRZ (Data)
		2	3	—	GHz	$V_{OUT} > 200$ mV (Clock)
Propagation Delay IN-to-Q	$t_{PD}$	170	280	420	ps	$V_{IN}$ : 100 mV - 200 mV
		130	200	300	ps	$V_{IN}$ : 200 mV - 800 mV
Within Device Skew	$t_{SKEW}$	—	5	20	ps	Note 2
Part-to-Part Skew		—	—	135	ps	Note 3
Additive Phase Jitter	$t_{JITTER}$	—	130	—	$f_{RMS}$	Carrier = 622 MHz Integration Range: 12 kHz – 20 MHz
Output Rise/Fall Time (20% to 80%)	$t_r, t_f$	35	60	100	ps	At full output swing
Duty Cycle	—	47	—	53	%	Differential I/O

**Note 1:** These high-speed parameters are guaranteed by design and characterization.

**2:** Within-device skew is measured between two different outputs under identical input transitions.

**3:** Part-to-part skew is defined for two parts with identical power supply voltages at the same temperature and no skew at the edges at the respective inputs.

## TEMPERATURE SPECIFICATIONS

Parameters	Sym.	Min.	Typ.	Max.	Units	Conditions
<b>Temperature Ranges</b>						
Operating Ambient Temperature Range	$T_A$	-40	—	+85	°C	—
Maximum Junction Operating Temperature	$T_J$	—	—	+125	°C	—
Storage Temperature Range	$T_A$	-65	—	+150	°C	—
<b>Package Thermal Resistances (Note 1)</b>						
Thermal Resistance, 3 x 3 QFN-16Ld	$\theta_{JA}$	—	60	—	°C/W	Still-air
	$\psi_{JB}$	—	33	—	°C/W	Junction-to-board

**Note 1:** Package thermal resistance assumes exposed pad is soldered (or equivalent) to the device's most negative potential on the PCB.  $\psi_{JB}$  and  $\theta_{JA}$  values are determined for a 4-layer board in still-air number, unless otherwise stated.

## 2.0 FUNCTIONAL DESCRIPTION

### 2.1 Fail-Safe Input (FSI)

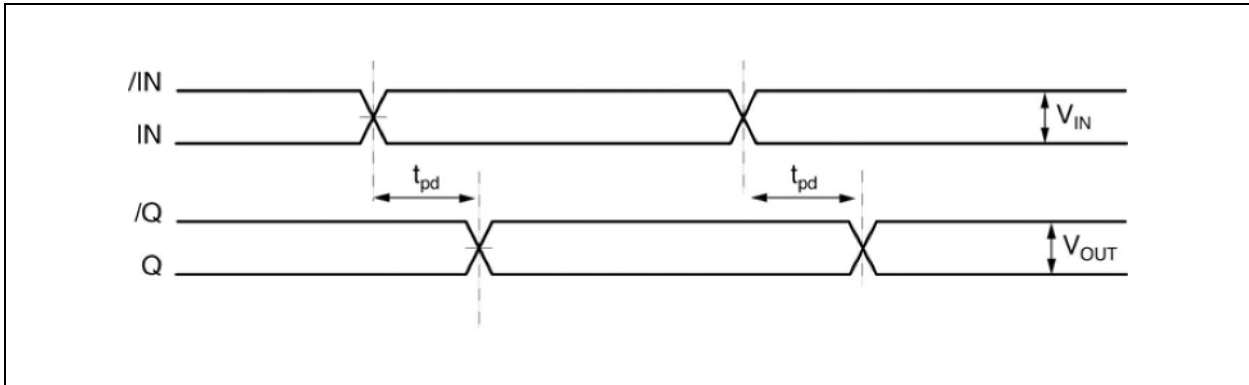
The input includes a special fail-safe circuit to sense the amplitude of the input signal and to latch the outputs when there is no input signal present, or when the amplitude of the input signal drops sufficiently below  $100\text{ mV}_{\text{PK}}$  ( $200\text{ mV}_{\text{PP}}$ ), typically  $30\text{ mV}_{\text{PK}}$ . Maximum frequency of SY58608U is limited by the FSI function.

### 2.2 Input Clock Failure Case

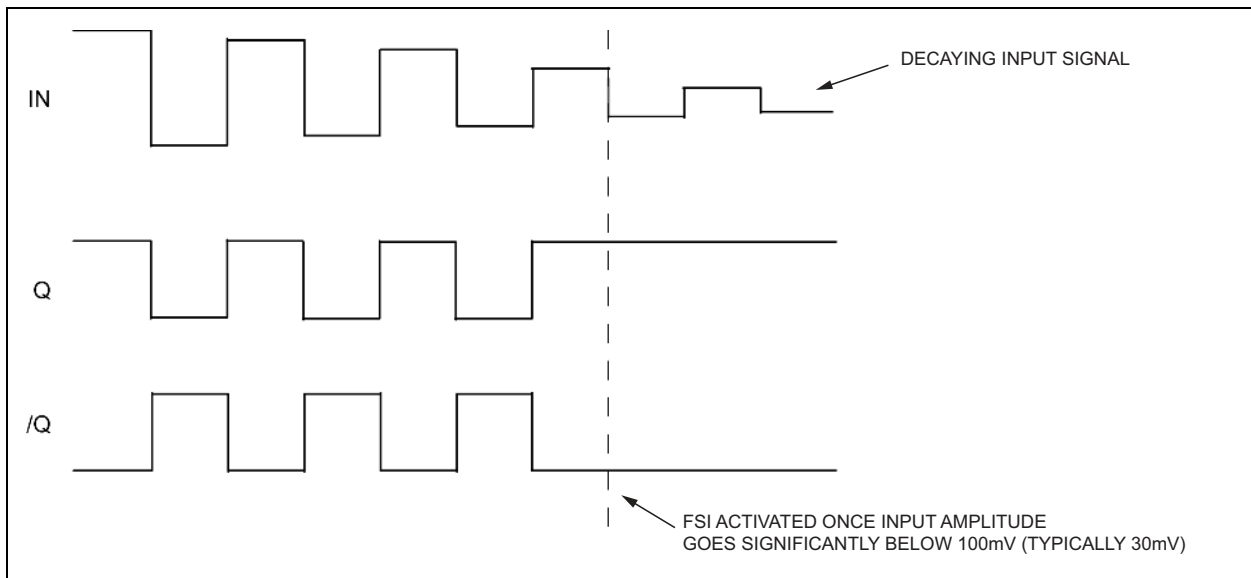
If the input clock fails to a floating, static, or extremely low signal swing such that the differential voltage across the input pair is less than  $100\text{ mV}$ , the FSI function will eliminate a metastable condition and latch the outputs to the last valid state. No ringing and no indeterminate state will occur at the output under these conditions. The output recovers to normal operation once the input signal returns to a valid state with a differential voltage  $\geq 100\text{ mV}$ .

Note that the FSI function will not prevent duty cycle distortion in case of a slowly deteriorating (but still toggling) input signal. Due to the FSI function, the propagation delay will depend on rise and fall time of the input signal and on its amplitude. Refer to "[Typical Performance Curves](#)" for detailed information.

## 3.0 TIMING DIAGRAMS



**FIGURE 3-1:** Propagation Delay.



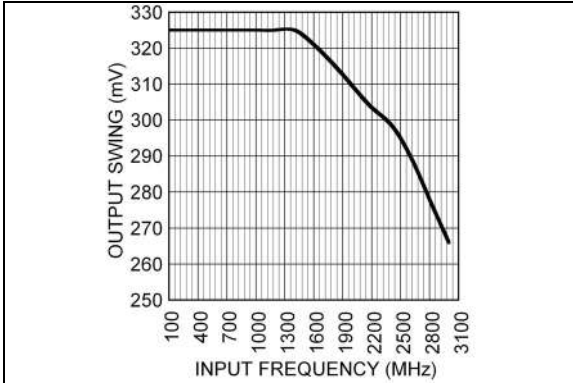
**FIGURE 3-2:** Fail Safe Feature.

# SY58608U

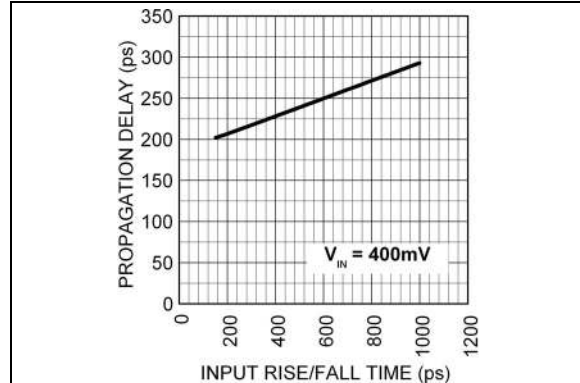
## 4.0 TYPICAL PERFORMANCE CURVES

**Note:** The graphs and tables provided following this note are a statistical summary based on a limited number of samples and are provided for informational purposes only. The performance characteristics listed herein are not tested or guaranteed. In some graphs or tables, the data presented may be outside the specified operating range (e.g., outside specified power supply range) and therefore outside the warranted range.

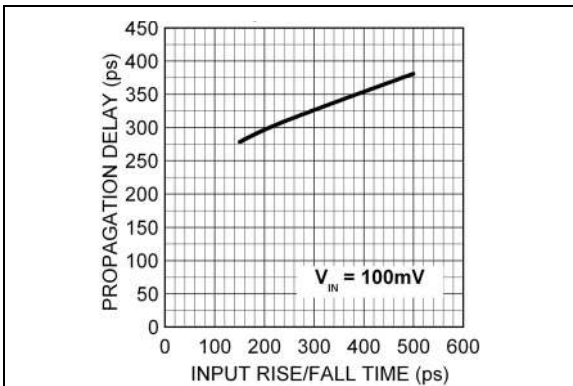
**NOTE:** Unless otherwise indicated,  $V_{CC} = 2.5V$ ,  $GND = 0V$ ,  $V_{IN} = 100\text{mV}$ ,  $R_L = 100\Omega$  across the output pairs,  $T_A = +25^\circ\text{C}$ .



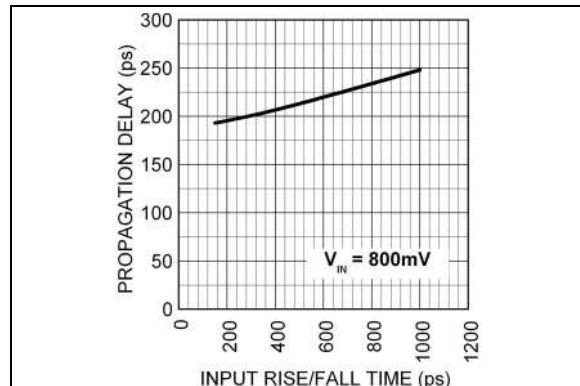
**FIGURE 4-1:** Frequency Response.



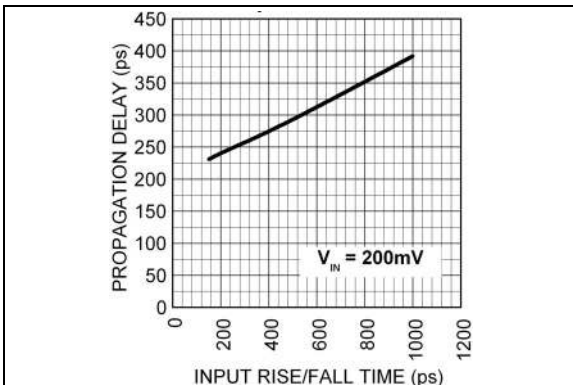
**FIGURE 4-4:** Propagation Delay vs. Input Rise/Fall Time.



**FIGURE 4-2:** Propagation Delay vs. Input Rise/Fall Time.

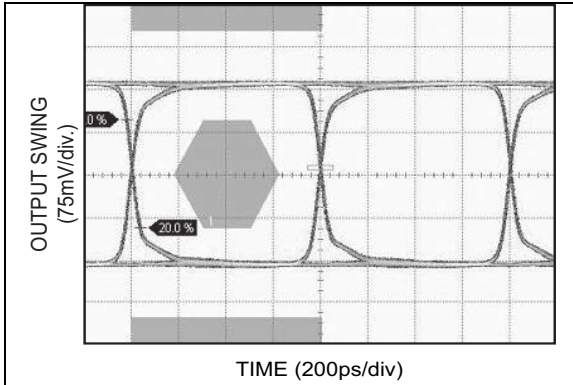


**FIGURE 4-5:** Propagation Delay vs. Input Rise/Fall Time.

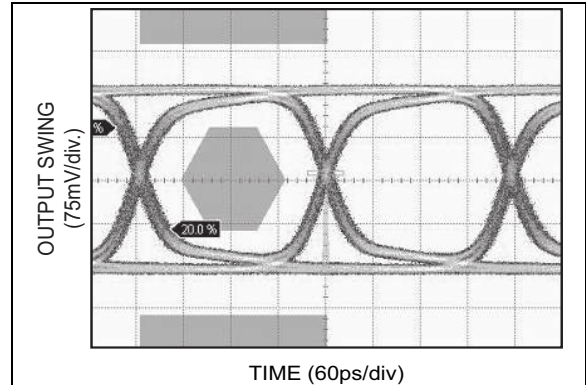


**FIGURE 4-3:** Propagation Delay vs. Input Rise/Fall Time.

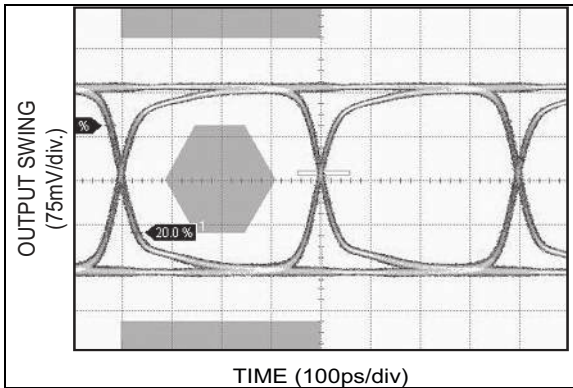




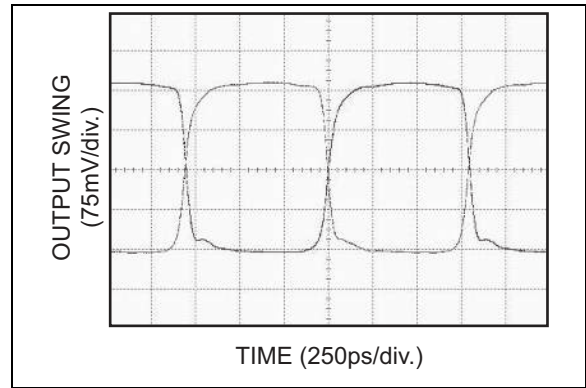
**FIGURE 4-6:** 1.25 Gbps Data.



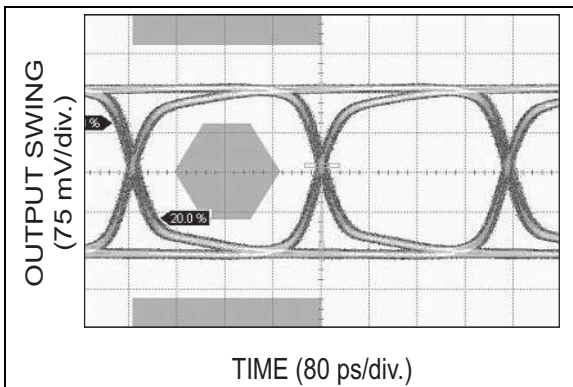
**FIGURE 4-9:** 4.25 Gbps Data.



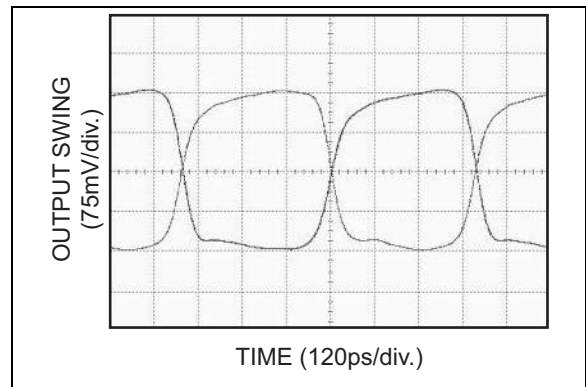
**FIGURE 4-7:** 2.5 Gbps Data.



**FIGURE 4-10:** 625 MHz Clock.



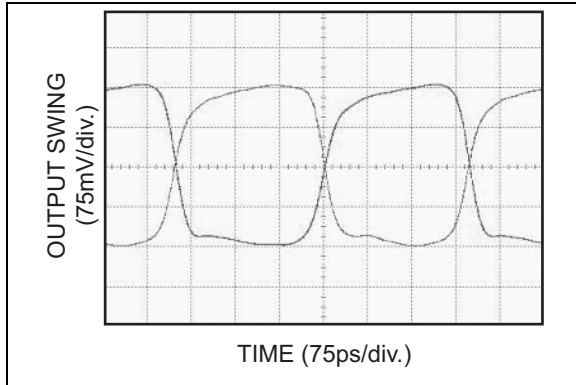
**FIGURE 4-8:** 3.2 Gbps Data.



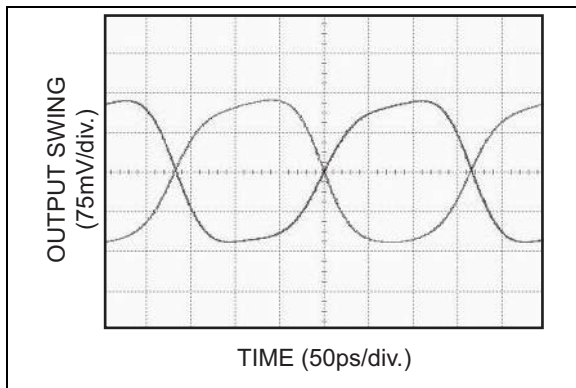
**FIGURE 4-11:** 1.25 GHz Clock.

# SY58608U

---



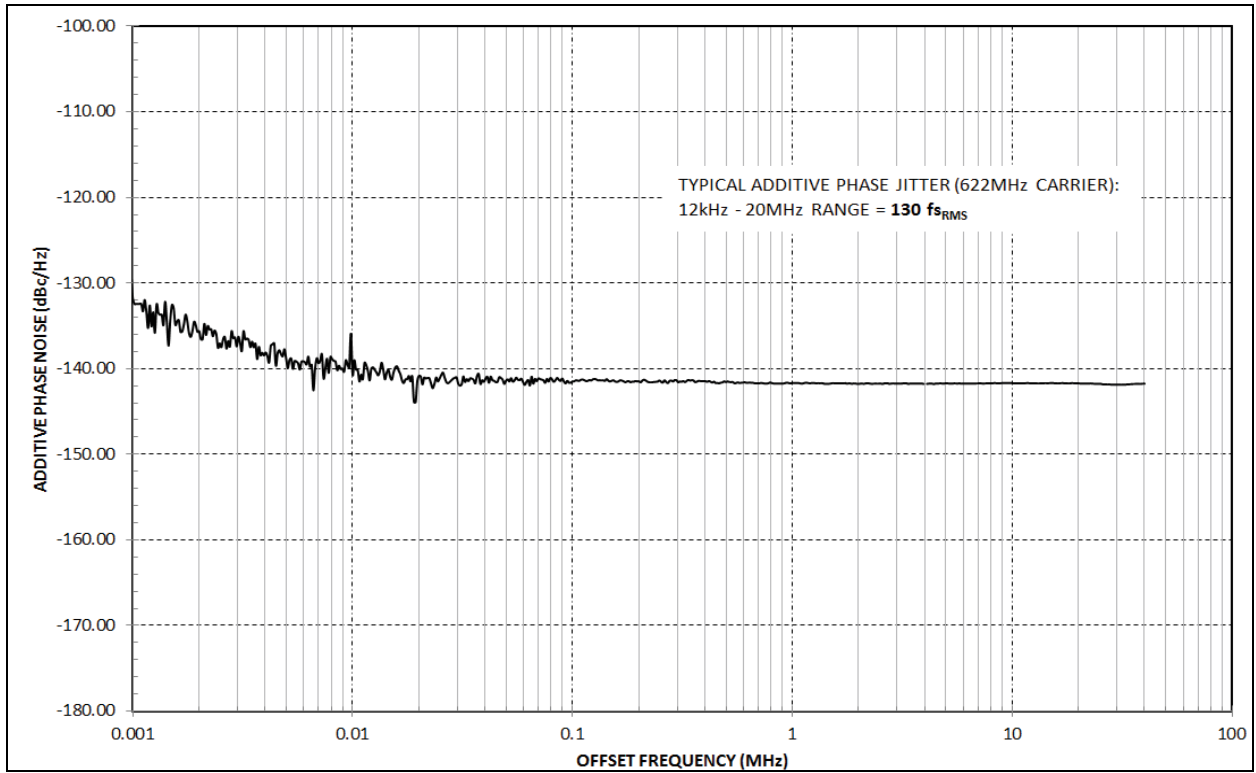
**FIGURE 4-12:** 2 GHz Clock.



**FIGURE 4-13:** 3 GHz Clock.

## 5.0 ADDITIVE PHASE NOISE PLOT

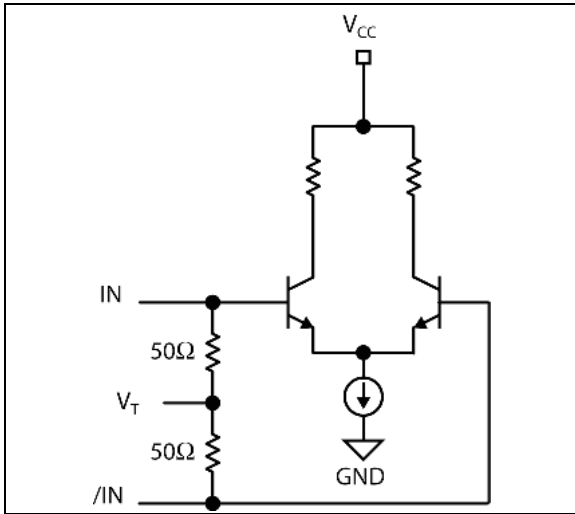
$V_{CC} = +2.5V$ ,  $T_A = 25^\circ C$ .



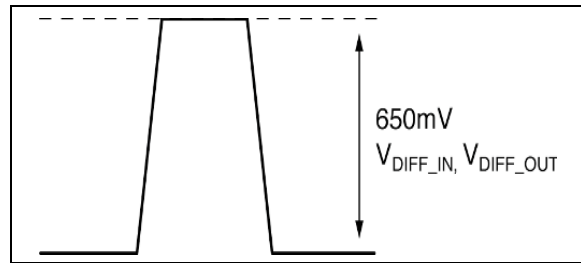
**FIGURE 5-1:** Additive Noise Plot.

# SY58608U

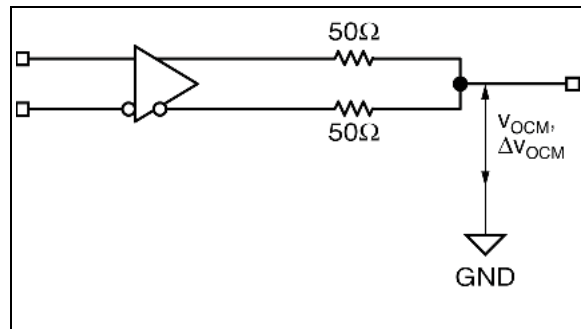
## 6.0 INPUT STAGE



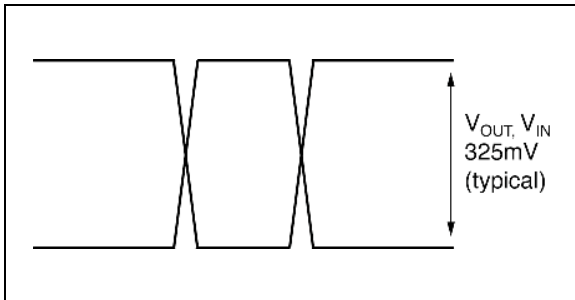
**FIGURE 6-1:** Simplified Differential Input Buffer.



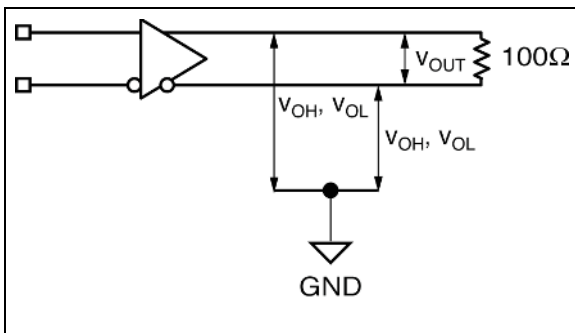
**FIGURE 6-4:** Differential Swing.



**FIGURE 6-5:** LVDS Common Mode Measurement.

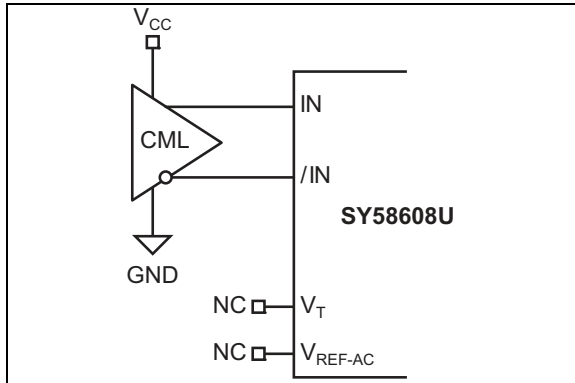


**FIGURE 6-2:** Single-Ended Swing.

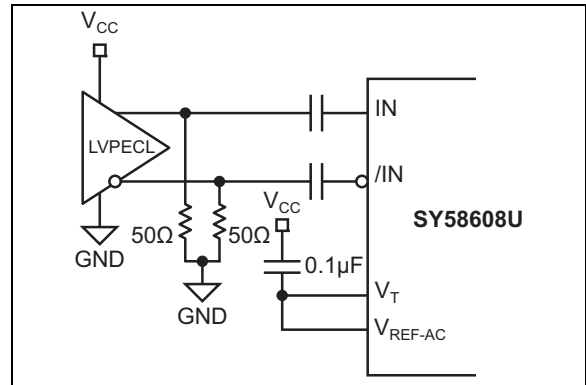


**FIGURE 6-3:** LVDS Differential Measurement.

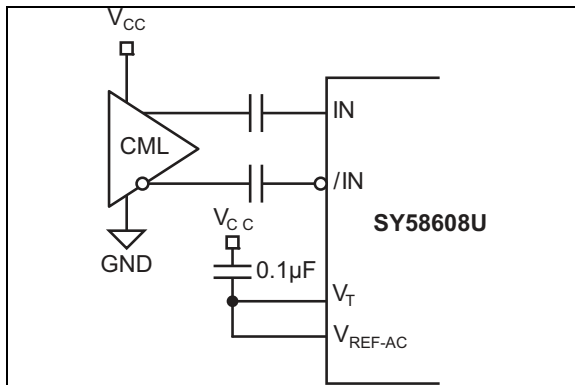
## 7.0 INPUT INTERFACE APPLICATIONS



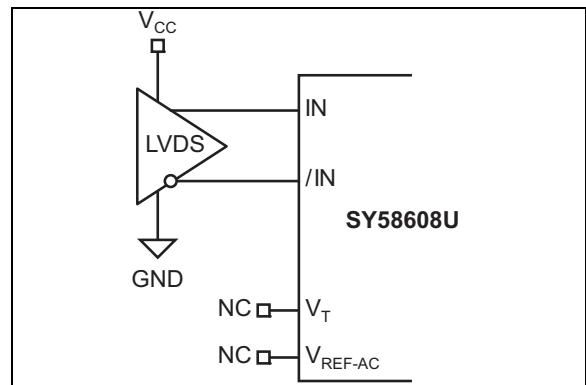
**FIGURE 7-1:** CML Interface (DC-Coupled).



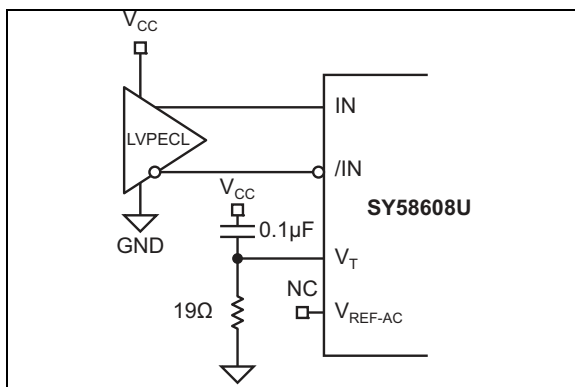
**FIGURE 7-4:** LVPECL Interface (AC-Coupled).



**FIGURE 7-2:** CML Interface (AC-Coupled).



**FIGURE 7-5:** LVDS Interface (DC-Coupled).



**FIGURE 7-3:** LVPECL Interface (DC-Coupled).

# SY58608U

## 8.0 PIN DESCRIPTIONS

The descriptions of the pins are listed in [Table 8-1](#).

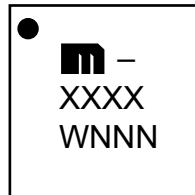
**TABLE 8-1: PIN FUNCTION TABLE**

Pin Number	Symbol	Description
1, 4	IN, /IN	Differential Inputs: This input pair is the differential signal input to the device. Input accepts DC-coupled differential signals as small as 100 mV (200 mV <sub>PP</sub> ). Each pin of this pair internally terminates with 50Ω to the V <sub>T</sub> pin. If the input swing falls below a certain threshold (typical 30 mV), the Fail Safe Input (FSI) feature will guarantee a stable output by latching the outputs to its last valid state. See “ <a href="#">Input Interface Applications</a> ” section for more details.
2	V <sub>T</sub>	Input Termination Center-Tap: Each input terminates to this pin. The V <sub>T</sub> pin provides a center-tap for each input (IN, /IN) to a termination network for maximum interface flexibility. See “ <a href="#">Input Interface Applications</a> ” section.
3	V <sub>REF-AC</sub>	Reference Voltage: This output bias to V <sub>CC</sub> -1.2V. It is used for AC-coupling inputs IN and /IN. Connect V <sub>REF-AC</sub> directly to the V <sub>T</sub> pin. Bypass with 0.01 μF low ESR capacitor to V <sub>CC</sub> . Maximum sink/source current is ±1.5 mA. See “ <a href="#">Input Interface Applications</a> ” section for more details.
5, 8, 13, 16	V <sub>CC</sub>	Positive Power Supply: Bypass with 0.1 μF//0.01 μF low ESR capacitors as close to the V <sub>CC</sub> pins as possible.
6, 7, 14, 15	GND, Exposed pad	Ground. Exposed pad must be connected to a ground plane that is the same potential as the ground pins.
9, 10 11, 12	/Q1, Q1 /Q0, Q0	LVDS Differential Output Pairs: Differential buffered output copy of the input signal. The output swing is typically 325 mV. Normally terminated 100Ω across the output pairs (Q and /Q).

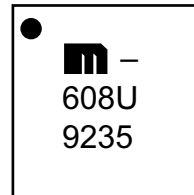
## 9.0 PACKAGING INFORMATION

### 9.1 Package Marking Information

16-Lead QFN\*



Example



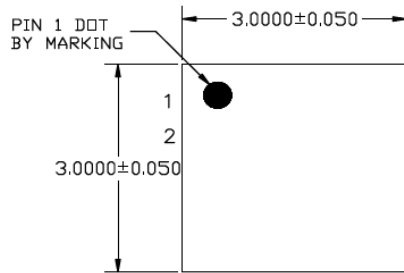
<b>Legend:</b>	XX...X	Product code or customer-specific information
	Y	Year code (last digit of calendar year)
	YY	Year code (last 2 digits of calendar year)
	WW	Week code (week of January 1 is week '01')
	NNN	Alphanumeric traceability code
	(e3)	Pb-free JEDEC® designator for Matte Tin (Sn)
	*	This package is Pb-free. The Pb-free JEDEC designator (e3) can be found on the outer packaging for this package.
	•, ▲, ▼	Pin one index is identified by a dot, delta up, or delta down (triangle mark).
<b>Note:</b>	In the event the full Microchip part number cannot be marked on one line, it will be carried over to the next line, thus limiting the number of available characters for customer-specific information. Package may or may not include the corporate logo.	
	Underbar ( _ ) and/or Overbar ( ¯ ) symbol may not be to scale.	

# SY58608U

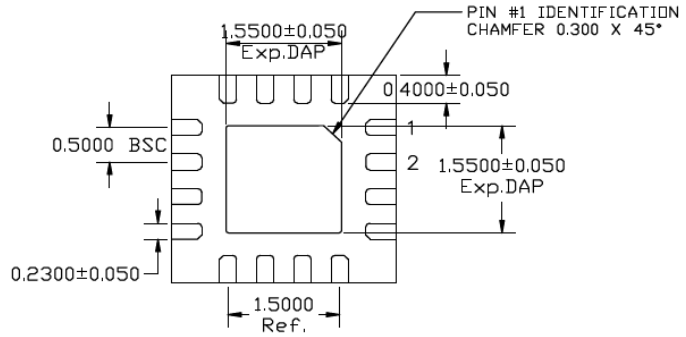
## TITLE

16 LEAD QFN 3x3mm PACKAGE OUTLINE & RECOMMENDED LAND PATTERN

DRAWING #	UNIT	MM
QFN33-16LD-PL-1		



TOP VIEW  
NOTE: 1, 2, 3



BOTTOM VIEW  
NOTE: 1, 2, 3



SIDE VIEW  
NOTE: 1, 2, 3

### NOTE:

1. MAX PACKAGE WARPAGE IS 0.05 MM
2. MAX ALLOWABLE BURR IS 0.076 MM IN ALL DIRECTIONS
3. PIN #1 IS ON TOP WILL BE LASER MARKED
4. RED CIRCLE IN LAND PATTERN INDICATE THERMAL VIA. SIZE SHOULD BE 0.30-0.35 MM IN DIAMETER AND SHOULD BE CONNECTED TO GND FOR MAX THERMAL PERFORMANCE
5. GREEN RECTANGLES (SHADED AREA) indicate SOLDER STENCIL OPENING ON EXPOSED PAD AREA. SIZE SHOULD BE 0.60x0.60 MM IN SIZE, 0.20 MM SPACING.

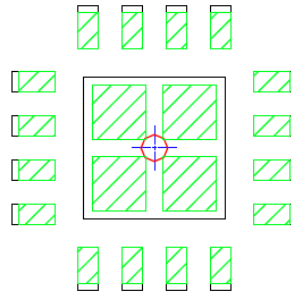
Note: For the most current package drawings, please see the Microchip Packaging Specification located at <http://www.microchip.com/packaging>.



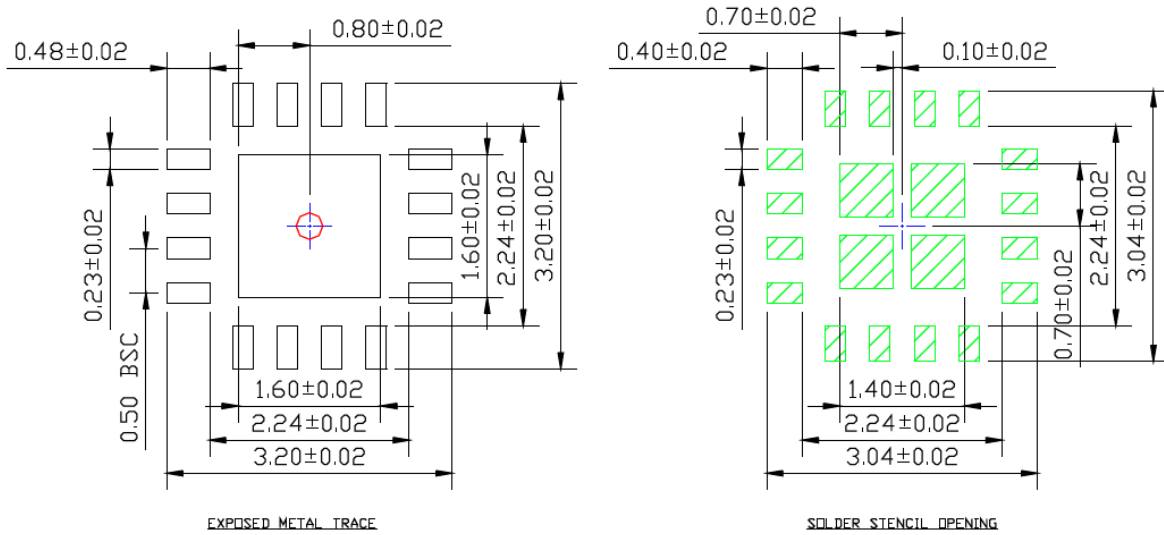
POD-Land Pattern drawing # QFN33-16LD-PL-1

## RECOMMENDED LAND PATTERN

NOTE: 4, 5



STACKED-UP



Note: For the most current package drawings, please see the Microchip Packaging Specification located at <http://www.microchip.com/packaging>.

# SY58608U

---

NOTES:

## APPENDIX A: REVISION HISTORY

### Revision A (December 2018)

- Converted Micrel document SY58608U to Microchip data sheet template DS20005605A.
- Minor text changes throughout.
- Corrected parameters of [Figure 4-12](#).
- Corrected parameters for [Figure 5-1](#).

# SY58608U

---

NOTES:

## PRODUCT IDENTIFICATION SYSTEM

To order or obtain information, e.g., on pricing or delivery, contact your local Microchip representative or sales office.

<u>PART NO.</u>		X	X	X	XX
Device	Output Voltage	Package	Temperature Range	Tape and Reel	
<b>Device:</b>	SY58608:	3.2 Gbps Precision, 1:2 LVDS Fanout Buffer with Internal Termination and Fail Safe Input			
<b>Output Voltage:</b>	U	=	2.5V		
<b>Package:</b>	M	=	QFN-16		
<b>Temperature Range:</b>	G	=	-40°C to 85°C (NiPdAu Lead-Free)		
<b>Special Processing:</b>	<blank>	=	100/Tube		
	TR	=	1,000/Reel		

<b>Examples:</b>	
a) SY58608UMG:	3.2 Gbps Precision, 1:2 LVDS Fanout Buffer with Internal Termination and Fail Safe Input, 2.5V or 3.3 V Output Voltage, QFN-16, -40°C to 85°C (NiPdAu Lead-Free), 100/Tube
b) SY58608UMGTR:	3.2 Gbps Precision, 1:2 LVDS Fanout Buffer with Internal Termination and Fail Safe Input, 2.5V or 3.3 V Output Voltage, QFN-16, -40°C to 85°C (NiPdAu Lead-Free), 1,000/Reel

**Note 1:** Tape and Reel identifier only appears in the catalog part number description. This identifier is used for ordering purposes and is not printed on the device package. Check with your Microchip Sales Office for package availability with the Tape and Reel option.

# SY58608U

---

NOTES:

---

---

**Note the following details of the code protection feature on Microchip devices:**

- Microchip products meet the specification contained in their particular Microchip Data Sheet.
- Microchip believes that its family of products is one of the most secure families of its kind on the market today, when used in the intended manner and under normal conditions.
- There are dishonest and possibly illegal methods used to breach the code protection feature. All of these methods, to our knowledge, require using the Microchip products in a manner outside the operating specifications contained in Microchip's Data Sheets. Most likely, the person doing so is engaged in theft of intellectual property.
- Microchip is willing to work with the customer who is concerned about the integrity of their code.
- Neither Microchip nor any other semiconductor manufacturer can guarantee the security of their code. Code protection does not mean that we are guaranteeing the product as “unbreakable.”

Code protection is constantly evolving. We at Microchip are committed to continuously improving the code protection features of our products. Attempts to break Microchip's code protection feature may be a violation of the Digital Millennium Copyright Act. If such acts allow unauthorized access to your software or other copyrighted work, you may have a right to sue for relief under that Act.

---

Information contained in this publication regarding device applications and the like is provided only for your convenience and may be superseded by updates. It is your responsibility to ensure that your application meets with your specifications. MICROCHIP MAKES NO REPRESENTATIONS OR WARRANTIES OF ANY KIND WHETHER EXPRESS OR IMPLIED, WRITTEN OR ORAL, STATUTORY OR OTHERWISE, RELATED TO THE INFORMATION, INCLUDING BUT NOT LIMITED TO ITS CONDITION, QUALITY, PERFORMANCE, MERCHANTABILITY OR FITNESS FOR PURPOSE. Microchip disclaims all liability arising from this information and its use. Use of Microchip devices in life support and/or safety applications is entirely at the buyer's risk, and the buyer agrees to defend, indemnify and hold harmless Microchip from any and all damages, claims, suits, or expenses resulting from such use. No licenses are conveyed, implicitly or otherwise, under any Microchip intellectual property rights unless otherwise stated.

*Microchip received ISO/TS-16949:2009 certification for its worldwide headquarters, design and wafer fabrication facilities in Chandler and Tempe, Arizona; Gresham, Oregon and design centers in California and India. The Company's quality system processes and procedures are for its PIC® MCUs and dsPIC® DSCs, KEELOQ® code hopping devices, Serial EEPROMs, microperipherals, nonvolatile memory and analog products. In addition, Microchip's quality system for the design and manufacture of development systems is ISO 9001:2000 certified.*

**QUALITY MANAGEMENT SYSTEM  
CERTIFIED BY DNV  
= ISO/TS 16949 =**

### **Trademarks**

The Microchip name and logo, the Microchip logo, AnyRate, AVR, AVR logo, AVR Freaks, BitCloud, chipKIT, chipKIT logo, CryptoMemory, CryptoRF, dsPIC, FlashFlex, flexPWR, Heldo, JukeBlox, KeeLoq, Klear, LANCheck, LINK MD, maXStylus, maXTouch, MediaLB, megaAVR, MOST, MOST logo, MPLAB, OptoLyzer, PIC, picoPower, PICSTART, PIC32 logo, Prochip Designer, QTouch, SAM-BA, SpyNIC, SST, SST Logo, SuperFlash, tinyAVR, UNI/O, and XMEGA are registered trademarks of Microchip Technology Incorporated in the U.S.A. and other countries.

ClockWorks, The Embedded Control Solutions Company, EtherSynch, Hyper Speed Control, HyperLight Load, IntellIMOS, mTouch, Precision Edge, and Quiet-Wire are registered trademarks of Microchip Technology Incorporated in the U.S.A.

Adjacent Key Suppression, AKS, Analog-for-the-Digital Age, Any Capacitor, AnyIn, AnyOut, BodyCom, CodeGuard, CryptoAuthentication, CryptoAutomotive, CryptoCompanion, CryptoController, dsPICDEM, dsPICDEM.net, Dynamic Average Matching, DAM, ECAN, EtherGREEN, In-Circuit Serial Programming, ICSP, INICnet, Inter-Chip Connectivity, JitterBlocker, KlearNet, KlearNet logo, memBrain, Mindi, MiWi, motorBench, MPASM, MPF, MPLAB Certified logo, MPLIB, MPLINK, MultiTRAK, NetDetach, Omniscient Code Generation, PICDEM, PICDEM.net, PICKit, PICtail, PowerSmart, PureSilicon, QMatrix, REAL ICE, Ripple Blocker, SAM-ICE, Serial Quad I/O, SMART-I.S., SQI, SuperSwitcher, SuperSwitcher II, Total Endurance, TSHARC, USBCheck, VariSense, ViewSpan, WiperLock, Wireless DNA, and ZENA are trademarks of Microchip Technology Incorporated in the U.S.A. and other countries.

SQTP is a service mark of Microchip Technology Incorporated in the U.S.A.

Silicon Storage Technology is a registered trademark of Microchip Technology Inc. in other countries.

GestIC is a registered trademark of Microchip Technology Germany II GmbH & Co. KG, a subsidiary of Microchip Technology Inc., in other countries.

All other trademarks mentioned herein are property of their respective companies.

© 2018, Microchip Technology Incorporated, All Rights Reserved.  
ISBN: 978-1-5224-3967-7



# MICROCHIP

## Worldwide Sales and Service

### AMERICAS

**Corporate Office**  
2355 West Chandler Blvd.  
Chandler, AZ 85224-6199  
Tel: 480-792-7200  
Fax: 480-792-7277  
Technical Support:  
<http://www.microchip.com/support>  
Web Address:  
[www.microchip.com](http://www.microchip.com)

#### Atlanta

Duluth, GA  
Tel: 678-957-9614  
Fax: 678-957-1455

#### Austin, TX

Tel: 512-257-3370

#### Boston

Westborough, MA  
Tel: 774-760-0087  
Fax: 774-760-0088

#### Chicago

Itasca, IL  
Tel: 630-285-0071  
Fax: 630-285-0075

#### Dallas

Addison, TX  
Tel: 972-818-7423  
Fax: 972-818-2924

#### Detroit

Novi, MI  
Tel: 248-848-4000

#### Houston, TX

Tel: 281-894-5983

#### Indianapolis

Noblesville, IN  
Tel: 317-773-8323  
Fax: 317-773-5453  
Tel: 317-536-2380

#### Los Angeles

Mission Viejo, CA  
Tel: 949-462-9523  
Fax: 949-462-9608  
Tel: 951-273-7800

#### Raleigh, NC

Tel: 919-844-7510

#### New York, NY

Tel: 631-435-6000

#### San Jose, CA

Tel: 408-735-9110  
Tel: 408-436-4270

#### Canada - Toronto

Tel: 905-695-1980  
Fax: 905-695-2078

### ASIA/PACIFIC

**Australia - Sydney**  
Tel: 61-2-9868-6733

**China - Beijing**  
Tel: 86-10-8569-7000

**China - Chengdu**  
Tel: 86-28-8665-5511

**China - Chongqing**  
Tel: 86-23-8980-9588

**China - Dongguan**  
Tel: 86-769-8702-9880

**China - Guangzhou**  
Tel: 86-20-8755-8029

**China - Hangzhou**  
Tel: 86-571-8792-8115

**China - Hong Kong SAR**  
Tel: 852-2943-5100

**China - Nanjing**  
Tel: 86-25-8473-2460

**China - Qingdao**  
Tel: 86-532-8502-7355

**China - Shanghai**  
Tel: 86-21-3326-8000

**China - Shenyang**  
Tel: 86-24-2334-2829

**China - Shenzhen**  
Tel: 86-755-8864-2200

**China - Suzhou**  
Tel: 86-186-6233-1526

**China - Wuhan**  
Tel: 86-27-5980-5300

**China - Xian**  
Tel: 86-29-8833-7252

**China - Xiamen**  
Tel: 86-592-2388138

**China - Zhuhai**  
Tel: 86-756-3210040

### ASIA/PACIFIC

**India - Bangalore**  
Tel: 91-80-3090-4444

**India - New Delhi**  
Tel: 91-11-4160-8631

**India - Pune**  
Tel: 91-20-4121-0141

**Japan - Osaka**  
Tel: 81-6-6152-7160

**Japan - Tokyo**  
Tel: 81-3-6880-3770

**Korea - Daegu**  
Tel: 82-53-744-4301

**Korea - Seoul**  
Tel: 82-2-554-7200

**Malaysia - Kuala Lumpur**  
Tel: 60-3-7651-7906

**Malaysia - Penang**  
Tel: 60-4-227-8870

**Philippines - Manila**  
Tel: 63-2-634-9065

**Singapore**  
Tel: 65-6334-8870

**Taiwan - Hsin Chu**  
Tel: 886-3-577-8366

**Taiwan - Kaohsiung**  
Tel: 886-7-213-7830

**Taiwan - Taipei**  
Tel: 886-2-2508-8600

**Thailand - Bangkok**  
Tel: 66-2-694-1351

**Vietnam - Ho Chi Minh**  
Tel: 84-28-5448-2100

### EUROPE

**Austria - Wels**  
Tel: 43-7242-2244-39  
Fax: 43-7242-2244-393

**Denmark - Copenhagen**  
Tel: 45-4450-2828  
Fax: 45-4485-2829

**Finland - Espoo**  
Tel: 358-9-4520-820

**France - Paris**  
Tel: 33-1-69-53-63-20  
Fax: 33-1-69-30-90-79

**Germany - Garching**  
Tel: 49-8931-9700

**Germany - Haan**  
Tel: 49-2129-3766400

**Germany - Heilbronn**  
Tel: 49-7131-67-3636

**Germany - Karlsruhe**  
Tel: 49-721-625370

**Germany - Munich**  
Tel: 49-89-627-144-0  
Fax: 49-89-627-144-44

**Germany - Rosenheim**  
Tel: 49-8031-354-560

**Israel - Ra'anana**  
Tel: 972-9-744-7705

**Italy - Milan**  
Tel: 39-0331-742611  
Fax: 39-0331-466781

**Italy - Padova**  
Tel: 39-049-7625286

**Netherlands - Drunen**  
Tel: 31-416-690399  
Fax: 31-416-690340

**Norway - Trondheim**  
Tel: 47-7288-4388

**Poland - Warsaw**  
Tel: 48-22-3325737

**Romania - Bucharest**  
Tel: 40-21-407-87-50

**Spain - Madrid**  
Tel: 34-91-708-08-90  
Fax: 34-91-708-08-91

**Sweden - Gothenberg**  
Tel: 46-31-704-60-40

**Sweden - Stockholm**  
Tel: 46-8-5090-4654

**UK - Wokingham**  
Tel: 44-118-921-5800  
Fax: 44-118-921-5820