

4

3

2

1

THIS DRAWING IS UNPUBLISHED. RELEASED FOR PUBLICATION ,19 .  
 © COPYRIGHT 19 BY AMP INCORPORATED. ALL RIGHTS RESERVED.

LOC	DIST	REVISIONS					
		P	LTR	DESCRIPTION	DATE	DWN	APVD
G	86		F	REV PER 0G3A-0637-01	030CT02	JR	MS

- △1 TIN PLATE 0.00381 [0.000150] MIN THK PER ASTM B 545
- △2 CLEANED, UNPLATED
- △3 PREPRODUCTION - FASR REQ

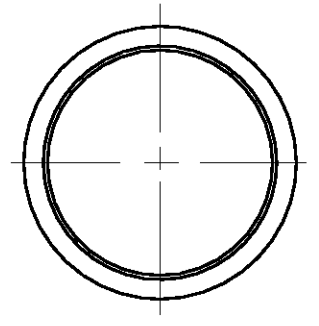
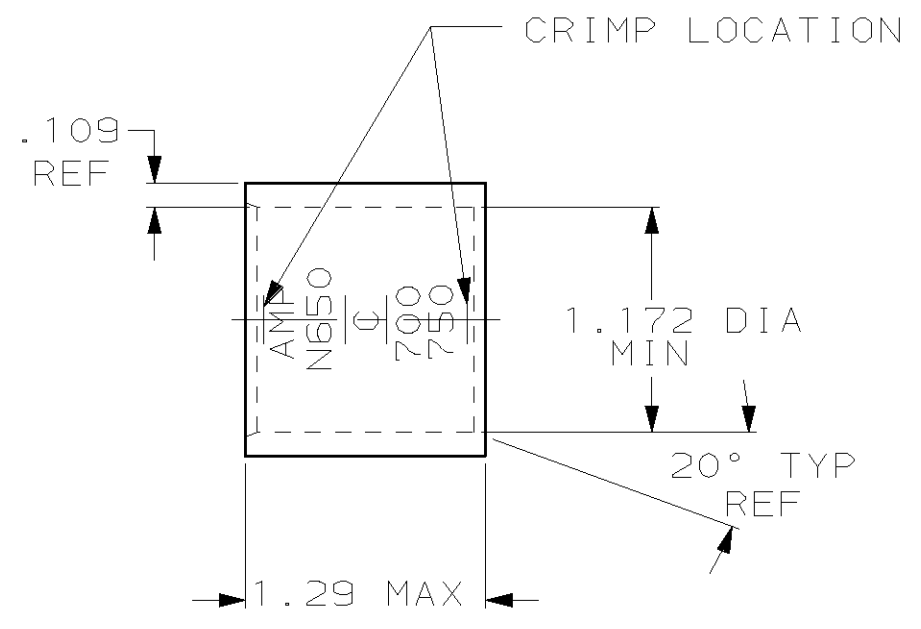

△2-	△31-324453-0
△1-	324453
FINISH	AMP PART NUMBER

THIS DRAWING IS A CONTROLLED DOCUMENT FOR AMP INCORPORATED. IT IS SUBJECT TO CHANGE AND THE CONTROLLING ENGINEERING ORGANIZATION SHOULD BE CONTACTED FOR THE LATEST REVISION.		DWN DK SCHRUM 01JUL96	<b>AMP</b> AMP Incorporated Harrisburg, PA 17105-3608
DIMENSIONS: mm [INCHES]		CHK WJ VOCKROTH 02JUL96	
TOLERANCES UNLESS OTHERWISE SPECIFIED:		APVD JL MECKLEY 02JUL96	NAME WIRE SPLICE, PARALLEL, AMPPOWER™ WIRE SIZE: 700 MCM
0 PLC ±- 1 PLC ±- 2 PLC ±- 3 PLC ±- 4 PLC ±- ANGLES ±-		PRODUCT SPEC -	SIZE A3
MATERIAL COPPER PER ASTM B-75 ANNEALED		APPLICATION SPEC -	CAGE CODE 00779
FINISH SEE TABLE		WEIGHT .181 lbs	DRAWING NO C-324453
		CUSTOMER DRAWING	SCALE 2:1 SHEET 1 OF 1 REV F