

LOC		DIST		REVISIONS			
P	LTN	REV	PER	ECO	DATE	DMN	APVD
N		REV PER ECO	16-003731		3-14-16	CT	RG

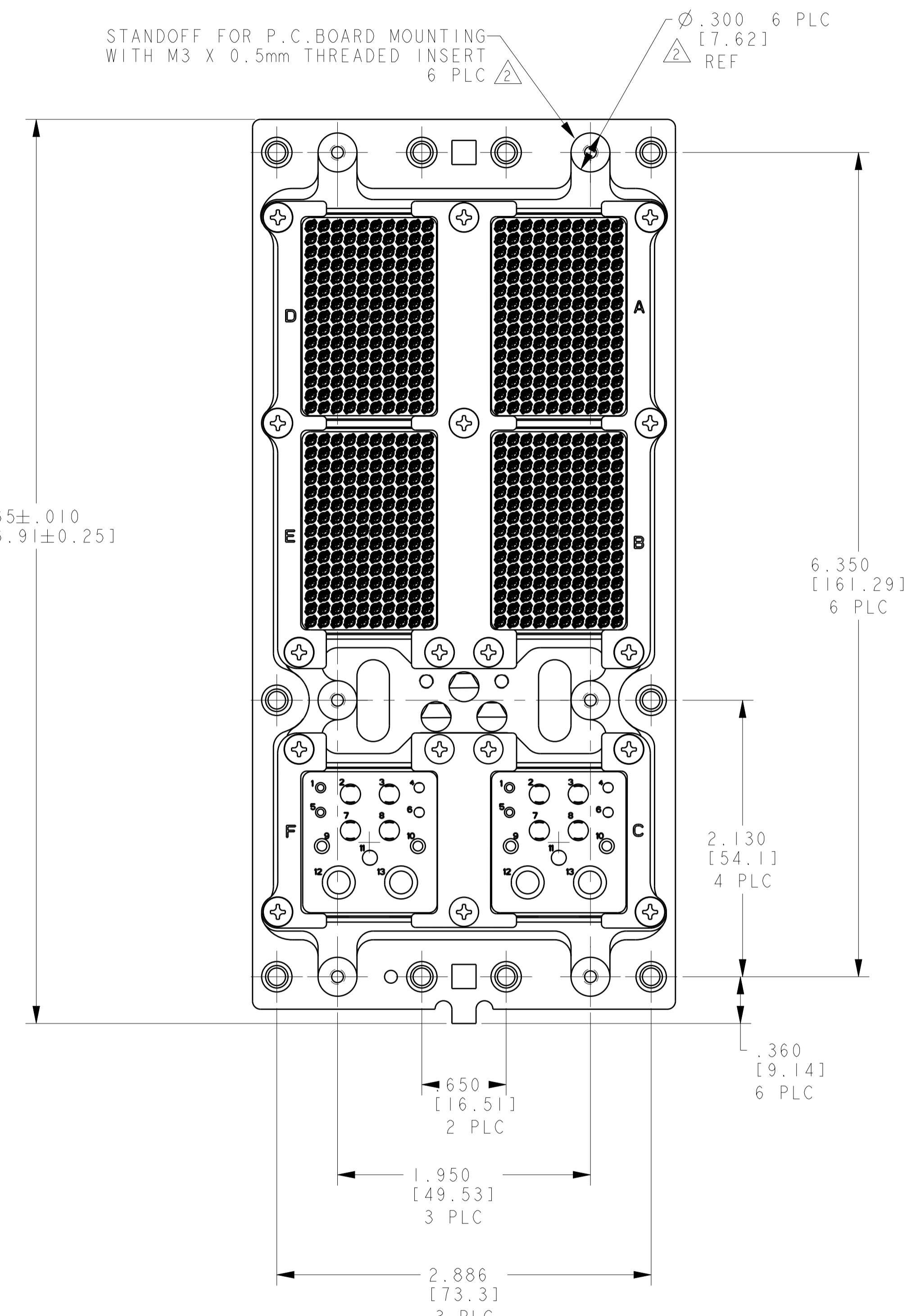
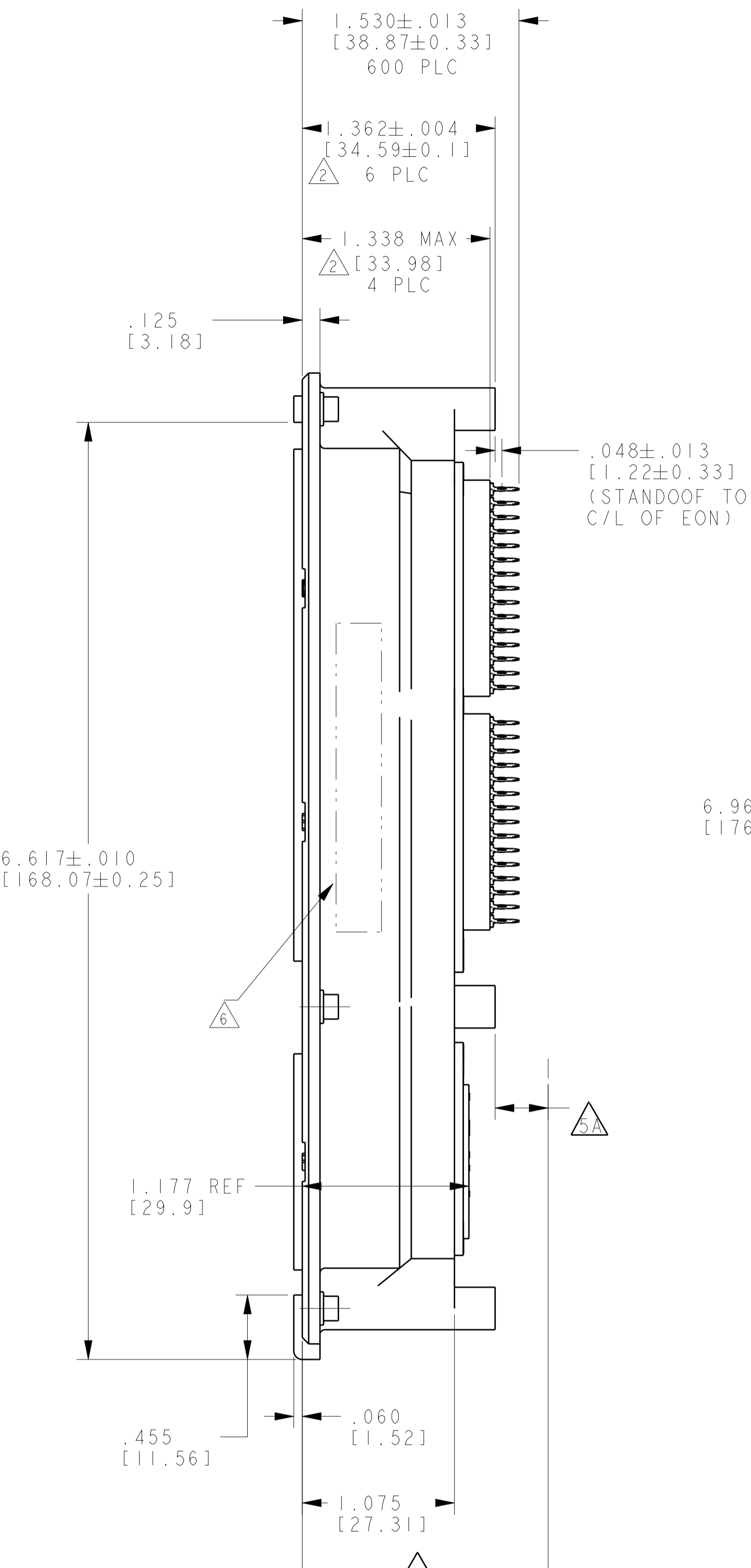
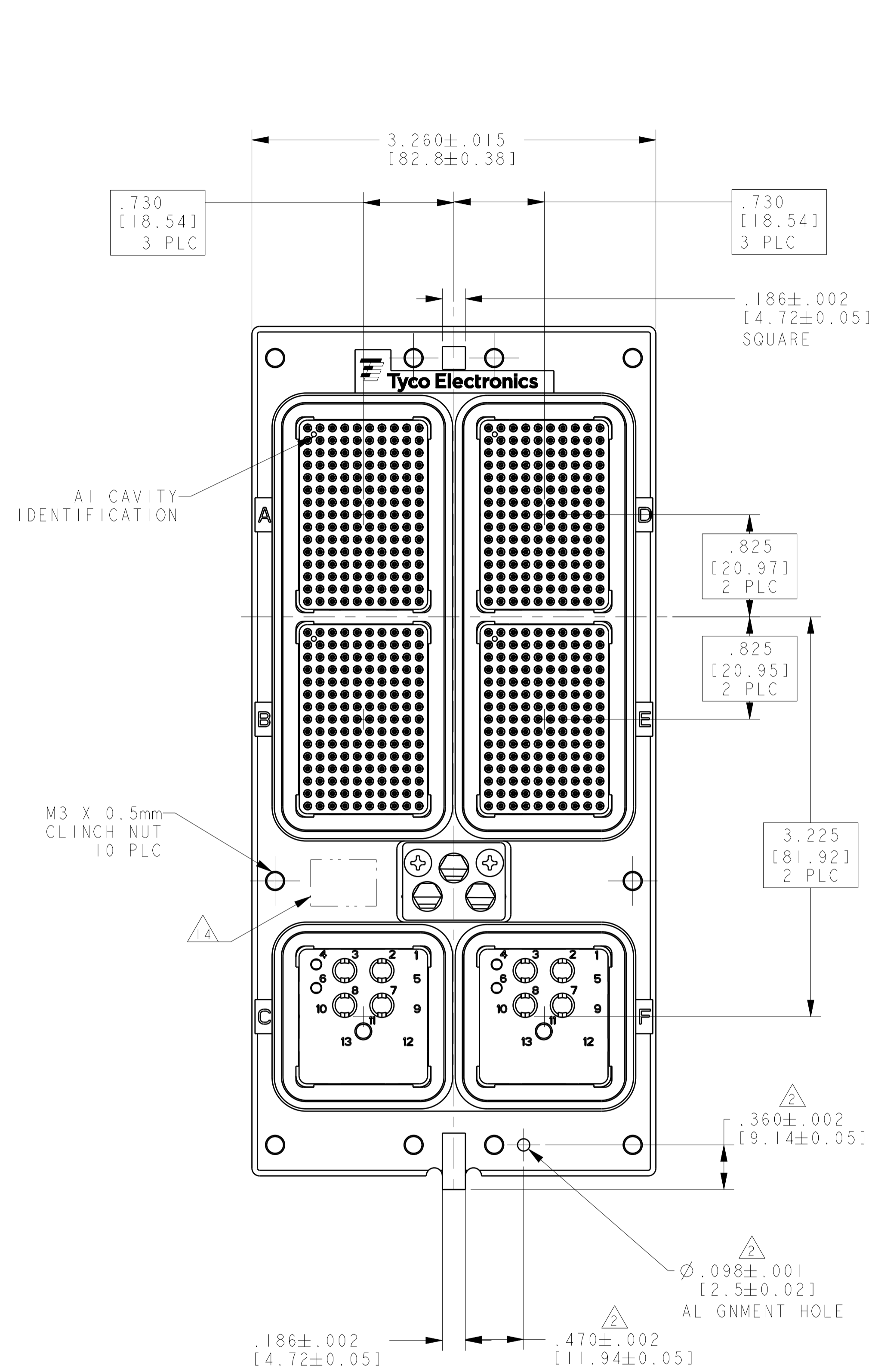

"00"	2101003-4
"00"	2101003-1
KEYING POSITION	PART NO.

THIS DRAWING IS A CONTROLLED DOCUMENT.		DMN: C.C. THOMAS 10-29-08	TE Connectivity NAME: RECEPTACLE ASSY, SIZE 3, ARINC 600 WITH PRESS FIT CONTACTS 150/150/13C2 SPCL/150/150/13C2 SPCL SIZE: CAGE CODE DRAWING NO: A100779C=2101003 WEIGHT: - MATERIAL: SEE CALLOUTS FINISH: SEE CALLOUTS CUSTOMER DRAWING
DIMENSIONS: INCHES [mm]		CHK: K. HOGAN 10-29-08	
TOLERANCES UNLESS OTHERWISE SPECIFIED:		APVD: K. HOGAN 10-29-08	
0 PLC ± 1 PLC ± 2 PLC ± 3 PLC ±.005 (0.13) 4 PLC ± ANGLES ±		PRODUCT SPEC APPLICATION SPEC SCALE: 3:2 SHEET 1 OF 2 REV N	

REVISONS		DATE	OWN	APVD
1	SEE SHEET 1			

- RECEPTACLE IS INTERMATEABLE TO ARINC 600 STYLE SIZE 3 PLUG ASSEMBLY
- ASSEMBLED CONNECTOR FEATURES COMPLY WITH ARINC 600 SPECIFICATION EXCEPT AS NOTED.
- THE FOLLOWING FILLER PLUGS FOR THE 13C2 INSERT ARE AVAILABLE, BUT NOT PROVIDED:
 SIZE 12 FILLER PLUG, TE PART NO. 1663767-4
 SIZE 16 FILLER PLUG, TE PART NO. 1663767-3
 SIZE 20 FILLER PLUG, TE PART NO. 1663767-2
- ASSEMBLED CONNECTOR IS IN AGREEMENT, AS NOTED, WITH THALES TECHNICAL PROCUREMENT SPECIFICATION J54625AA-REV-02 AND CUSTOMER PURCHASING REQUIREMENTS SPECIFICATION 128-1089.
- THE FOLLOWING POSTED PIN CONTACTS FOR THE 13C2 INSERT ARE AVAILABLE BUT NOT INCLUDED.
 (5A) THE MINIMUM POST EXTENSION BEYOND STANDOFF IS: .160 [4.06].
 (5B) MAXIMUM POST EXTENSION FROM FRONT FACE IS 1.579 [40.11].
 THE CONTACTS ARE RoHS COMPLIANT; SN-DIPPED.
 SIZE 12 POSTED PIN CONTACT, TE PART NO. 2-448140-3
 SIZE 16 POSTED PIN CONTACT, TE PART NO. 3-448139-4
 SIZE 20 POSTED PIN CONTACT, TE PART NO. 3-448138-2
- MANUFACTURERS PART NO. AND DATE CODE (YY-WW) MARKED IN AREA SHOWN.
- ESTIMATED WEIGHT OF CONNECTOR ASSEMBLY AS SHOWN: 485 GRAMS.
- MAX LOCKING TORQUE FOR M3 CLINCH NUTS: 0.34 N-m (3.0 in-lbf)
 MAX LOCKING TORQUE FOR M3 THREADED INSERTS: 0.45 N-m (4.0 in-lbf)
 MAX LOCKING TORQUE IS VALID FOR FIRST CYCLE ONLY. MAX LOCKING TORQUE REFERS TO THE TORQUE REQUIRED TO OVERCOME THE LOCKING FEATURE OF THE CLINCH NUT OR THREADED INSERT. TORQUE VALUES ARE FOR REFERENCE ONLY.
- CONDUCTIVE DUST COVER INSTALLED FOR SHIPPING. (NOT SHOWN)
- EYE OF THE NEEDLE CONTACT DESIGN CONSIDERATIONS:
 (A) PCB HOLE DIAMETER: 0.90mm PER IEC 60352-5
 (B) MINIMUM PCB THICKNESS: .063 [1.6]
 (C) PCB PLATING: Sn PLATE RECOMMENDED
 (D) NORMAL INSERTION FORCE: 8 lb MAX PER CONTACT;
 900 lb AVERAGE PER 150 POSITION INSERT ASSEMBLY
- KEYING SHOWN IN POSITION "01" FOR REFERENCE ONLY. KEYING HARDWARE IS INCLUDED BUT SHIPPED UNASSEMBLED.
- CONNECTOR PACKAGING SHALL HAVE A LABEL WHICH WILL INCLUDE, AT A MINIMUM, THE THALES PART NUMBER, THE TE CONNECTIVITY PART NUMBER AND THE MANUFACTURING DATE CODE.
- RoHS CODE IS "L" AS DEFINED IN TEC-238-2 DUE TO HEXAVALENT CHROMATE CONVERSION FINISH ON SHELL AND RETAINER PLATES.
- TE LOGO APPEARS IN THIS APPROXIMATE LOCATION ON SHELLS MACHINED FROM BILLET.
- ASSEMBLY SHOWN WITH DIE-CAST SHELL. ASSEMBLIES WITH MACHINED SHELLS MAY VARY SLIGHTLY IN APPEARANCE.

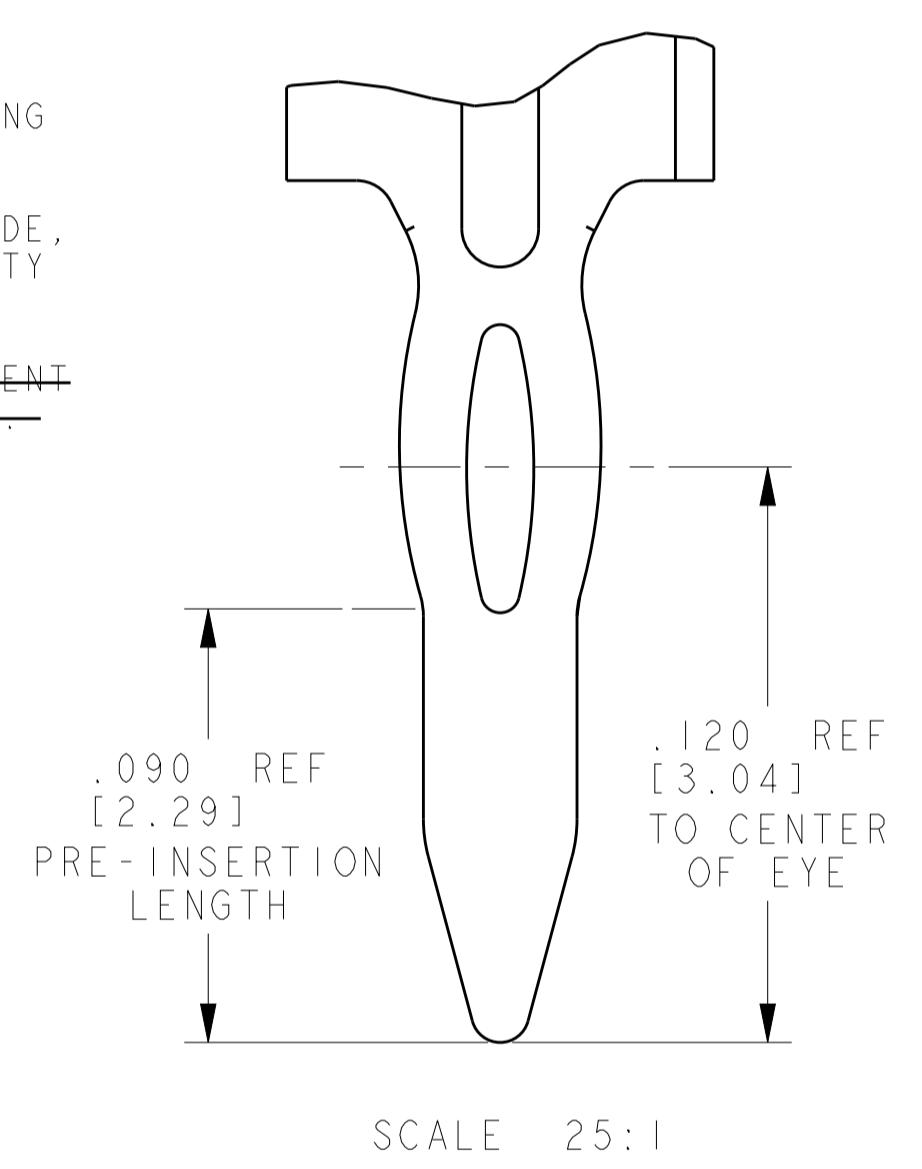

PCB STANDOFF (REF) 6 PLC
 NOMINAL HOLE DIAMETER 0.90 mm PER IEC 60352-5 FOR 150 POSN. INSERT 600 HOLES

⊕ ∅.005 X Y

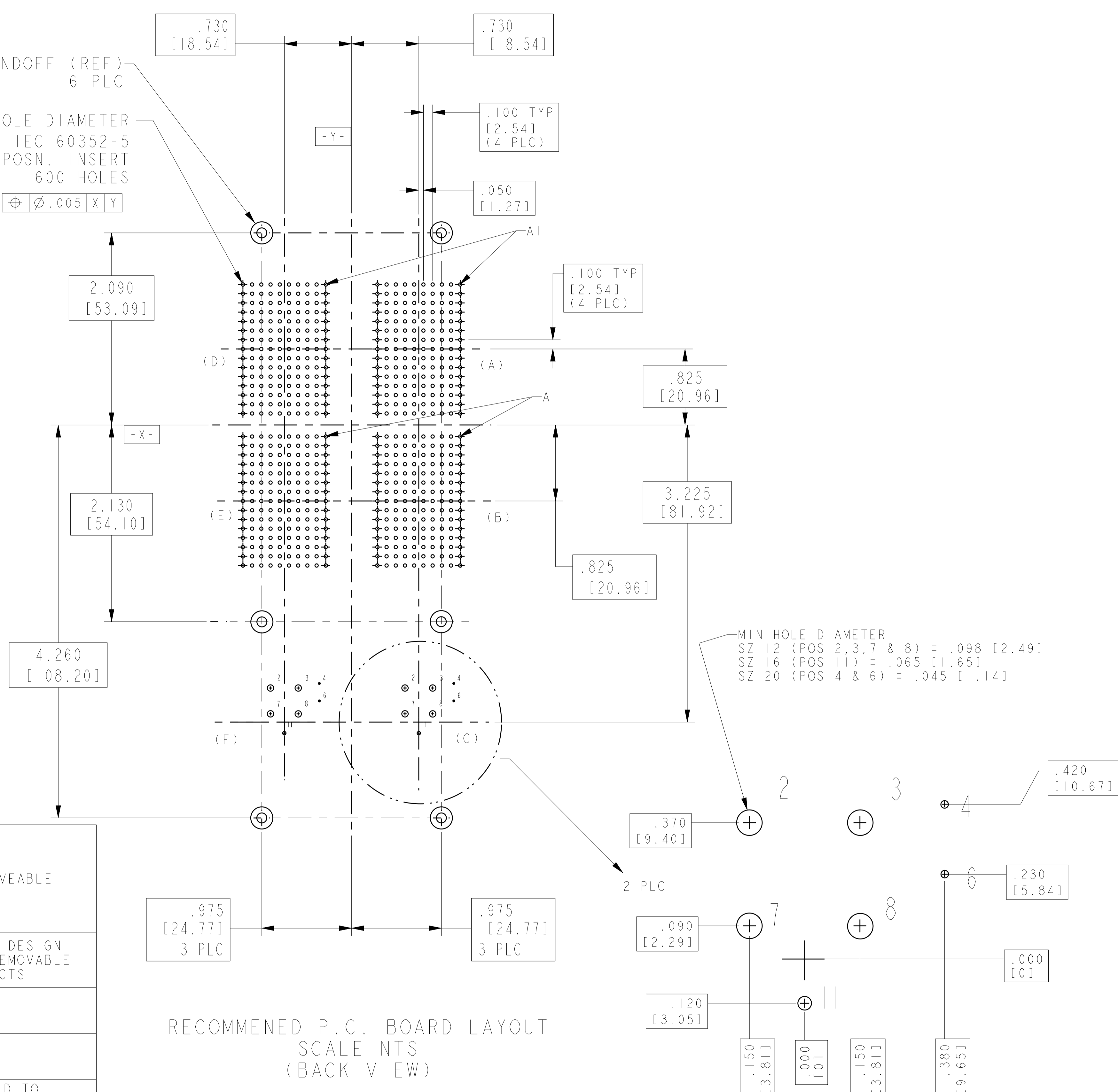

MIN HOLE DIAMETER
 SZ 12 (POS 2, 3, 7 & 8) = .098 [2.49]
 SZ 16 (POS 11) = .065 [1.65]
 SZ 20 (POS 4 & 6) = .045 [1.14]

COMPONENT	MATERIAL	FINISH	REMARKS
SIZE 22 SOCKET CONTACTS QTY = 600	BODY: COPPER ALLOY HOOD: STAINLESS STEEL	BODY: .000050 [1.27um] MIN GOLD ON MATING TINES, Sn ON EON TAIL, BOTH OVER NICKEL PLATE HOOD: PASSIVATED	NON REMOVEABLE
150 POSITION INSERT 4 PLC	THERMOPLASTIC	NONE	ONE PIECE DESIGN WITH NON-REMOVABLE CONTACTS
M3 THREADED INSERT 6 PLC	STAINLESS STEEL	DRY FILM LUBRICANT	
M3 CLINCH NUT 10 PLC	STEEL	ZINC PLATED WITH SUPP YELLOW TRIVALENT CHROMATE	
13C2 INSERT ASSY FRONT RELEASE/REMOVE	THERMOSET	NONE	MODIFIED TO PERMANENTLY CLOSE CAVITIES 1, 5, 9, 10, 12 & 13
SHELL & RETENTION PLATES	ALUMINUM ALLOY PER ASTM-B-85 OR ASTM B 211, 6061T6 OR ASTM B 209, 2024T4	FOR -1 CHROMATE CONVERSION PER MIL-C-5541 TYPE I CLASS 1A FOR -4 CHROMATE CONVERSION PER MIL-C-5541 TYPE II, CLASS 3	

RECOMMENDED P.C. BOARD LAYOUT SCALE NTS (BACK VIEW)

THIS DRAWING IS A CONTROLLED DOCUMENT. DIMENSIONS: INCHES [mm]. TOLERANCES UNLESS OTHERWISE SPECIFIED: 0 PLC ±, 1 PLC ±, 2 PLC ±, 3 PLC ±, 4 PLC ±, ANGLES ±. MATERIAL SEE CALLOUTS. FINISH SEE CALLOUTS.

OWN: C.C. THOMAS 10-29-08
 CHK: K. HOGAN 10-29-08
 APVD: K. HOGAN 10-29-08

TE Connectivity
 RECEPTACLE ASSY, SIZE 3, ARINC 600 WITH PRESS FIT CONTACTS (150/150/13C2 SPCL/150/150/13C2 SPCL)

SIZE: A1 CAGE CODE: 2101003 DRAWING NO: 100779

CUSTOMER DRAWING SCALE: 1:1 SHEET 2 OF 2 REV N