

| LOC | DIST | P | F | ZONE | LTR | REVISIONS       |         |      |
|-----|------|---|---|------|-----|-----------------|---------|------|
|     |      |   |   |      |     | DESCRIPTION     | DATE    | APPD |
|     |      |   |   |      | K   | EC 0010-1457-95 | 1/18/96 | CR   |
|     |      |   |   |      | L   | EC 0010-0318-96 | 4/1/96  | CR   |
|     |      |   |   |      | M   | EC 0010-1469-95 | 4/1/96  | CR   |
|     |      |   |   |      | N   | EC 0010-0895-96 | 6/24/96 | CR   |

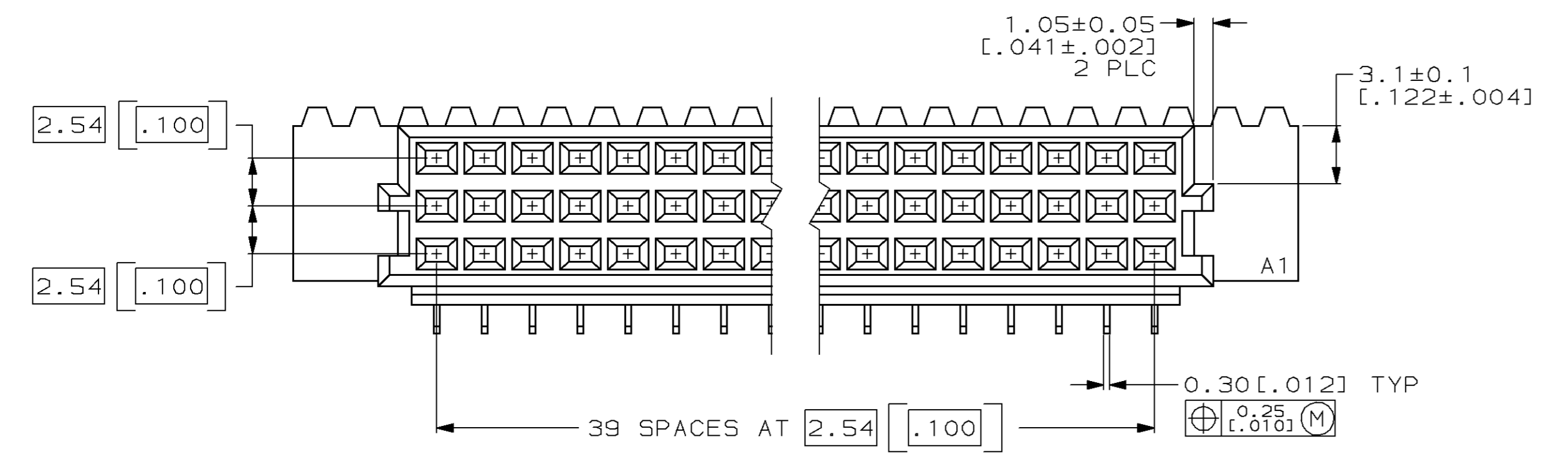

1. DIMENSIONS IN BRACKETS ARE IN INCHES.
2. HOUSING MATERIAL: GLASS-FILLED POLYESTER. COLOR: GRAY.
3. CONTACT MATERIAL: PHOSPHOR BRONZE.
4. CONTACT FINISH: 0.00076 [.000030] GOLD IN CONTACT AREA. 0.00127 [.000050] NICKEL UNDERPLATE ALL OVER. TIN-LEAD ON POSTS.
5. RECOMMENDED HOLE SIZE FOR MANUAL APPLICATION OF CONNECTOR ONTO PC BOARD.
6. PART NUMBER, DATE CODE IDENTIFICATION, CSA LOGO HOT-STAMPED THIS APPROXIMATE AREA.
7. CONTACT POINT.
8. HOT-STAMPING ON THIS SIDE.
9. CONTACT FINISH: DIN 41612 CLASS 3 IN CONTACT AREA. TIN-LEAD ON POSTS.
10. CONTACT FINISH: DIN 41612 CLASS 2 IN CONTACT AREA. TIN-LEAD ON POSTS.

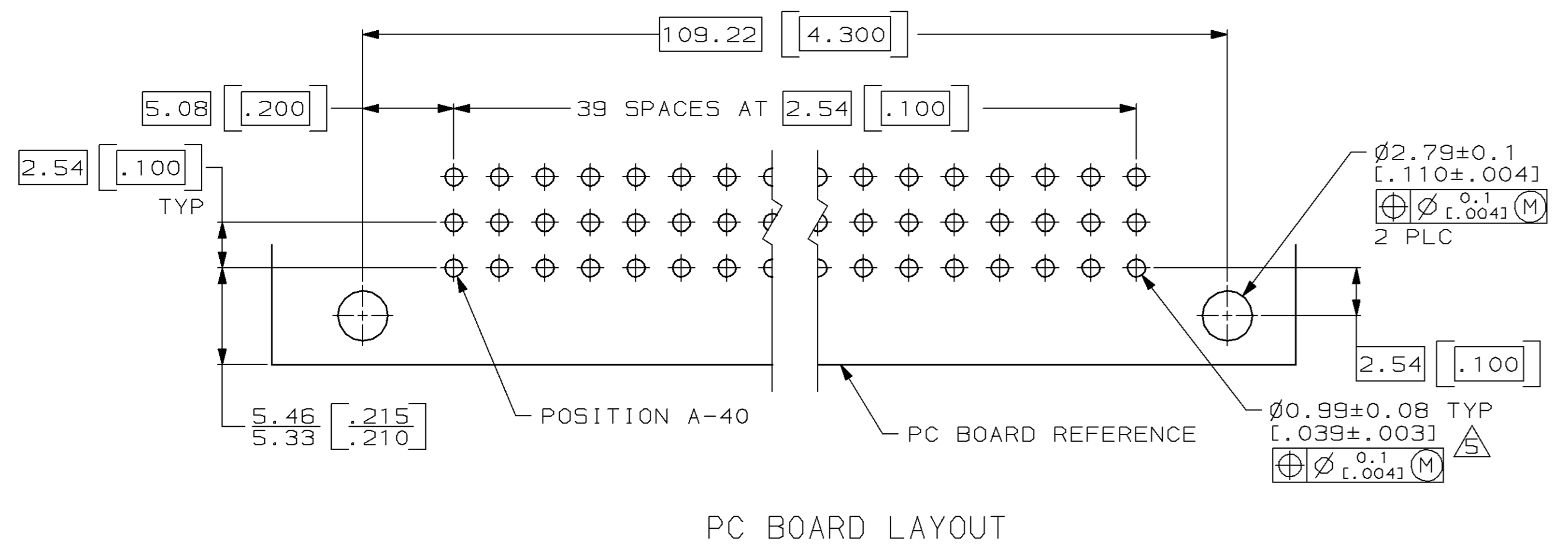
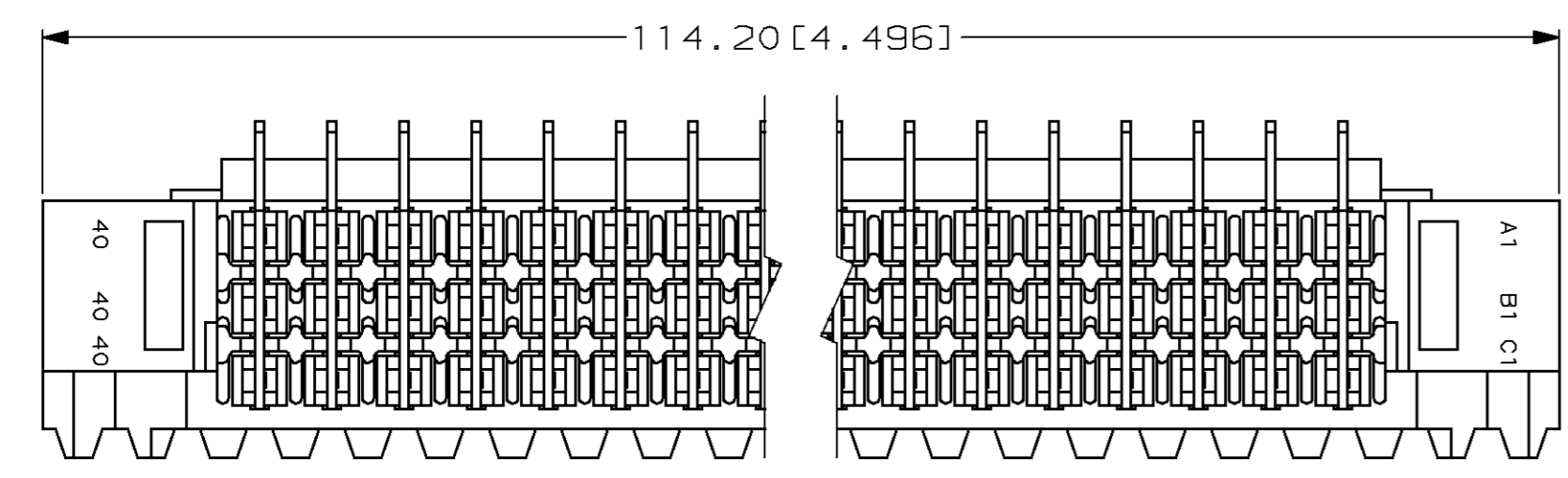
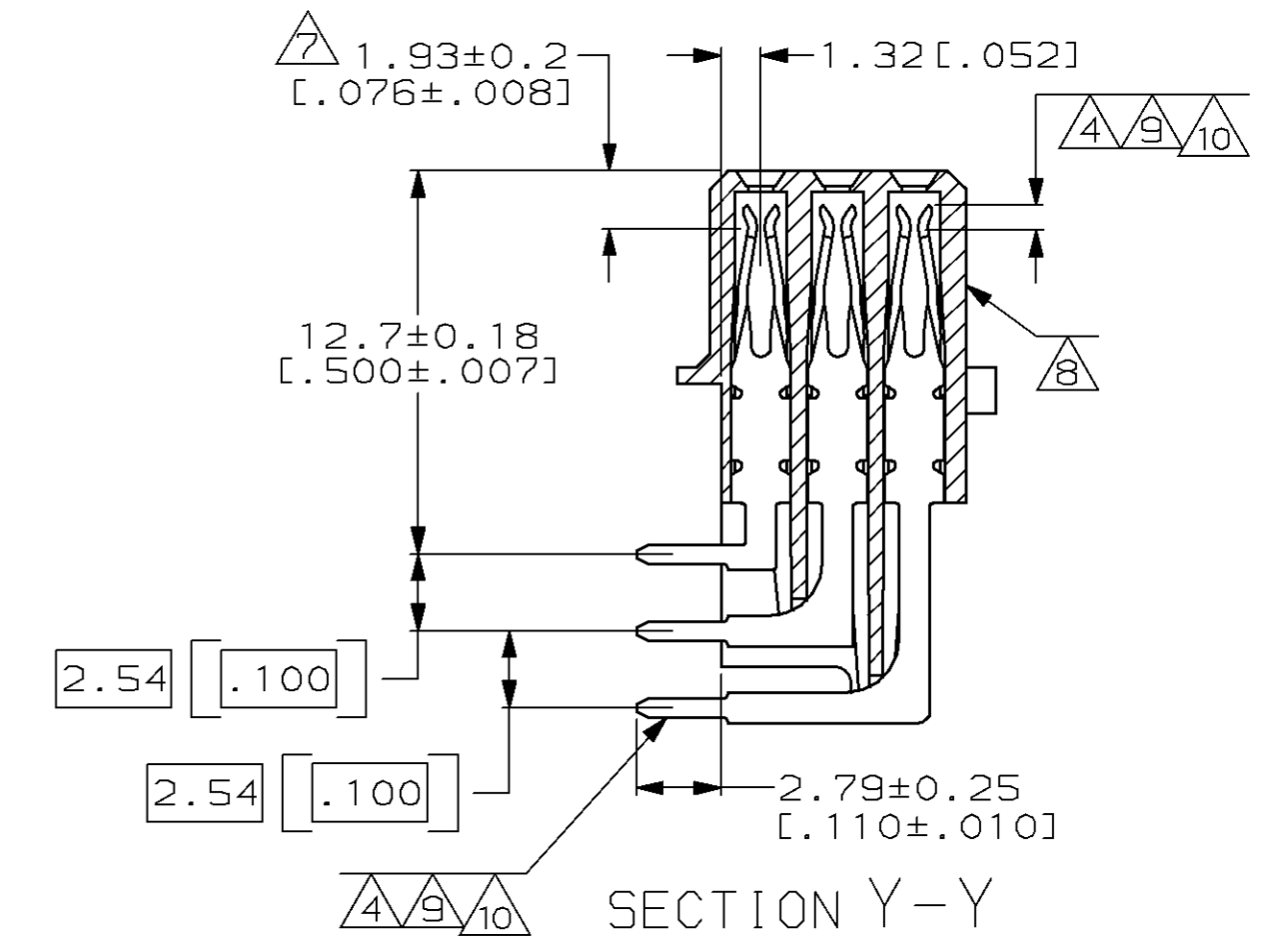
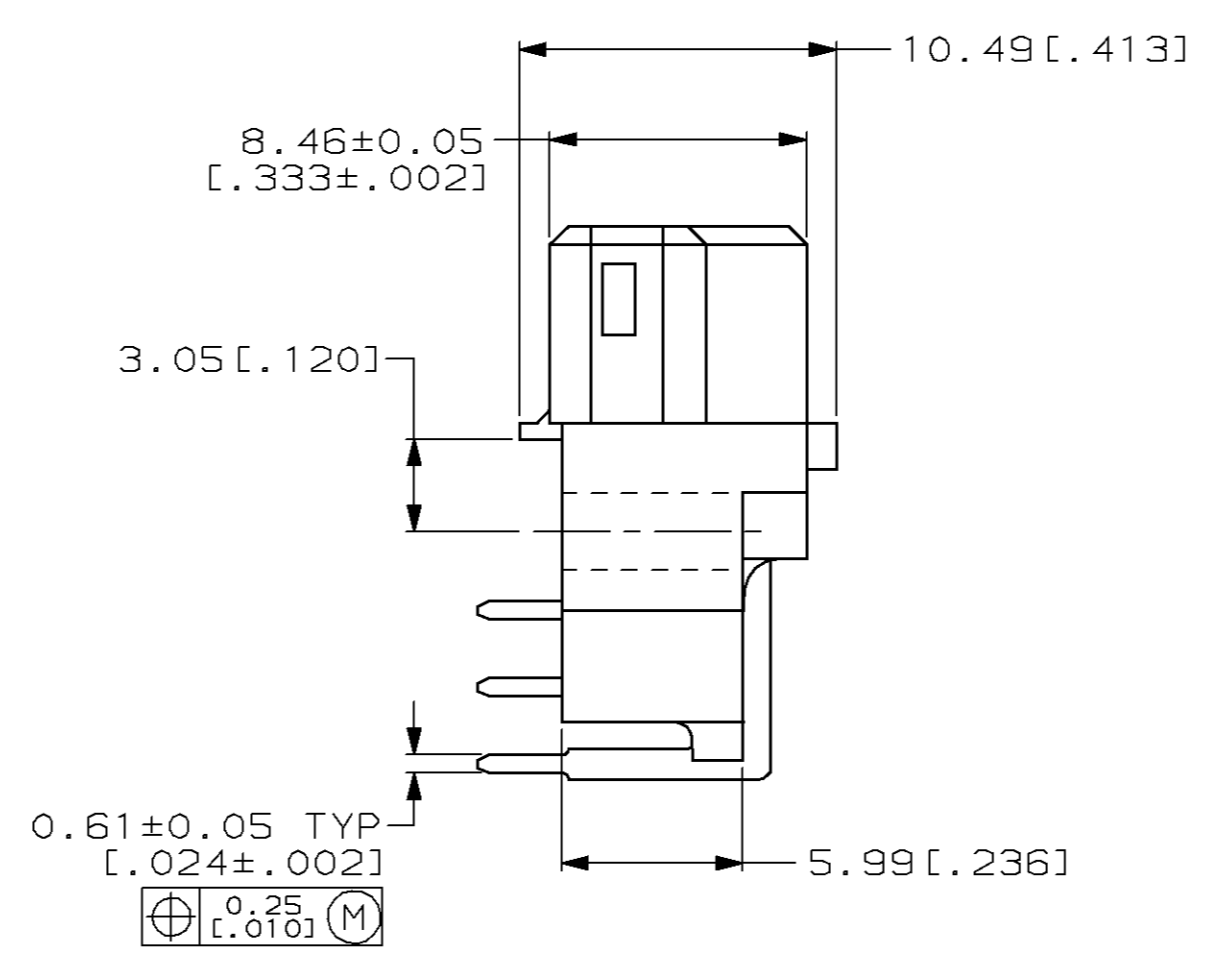
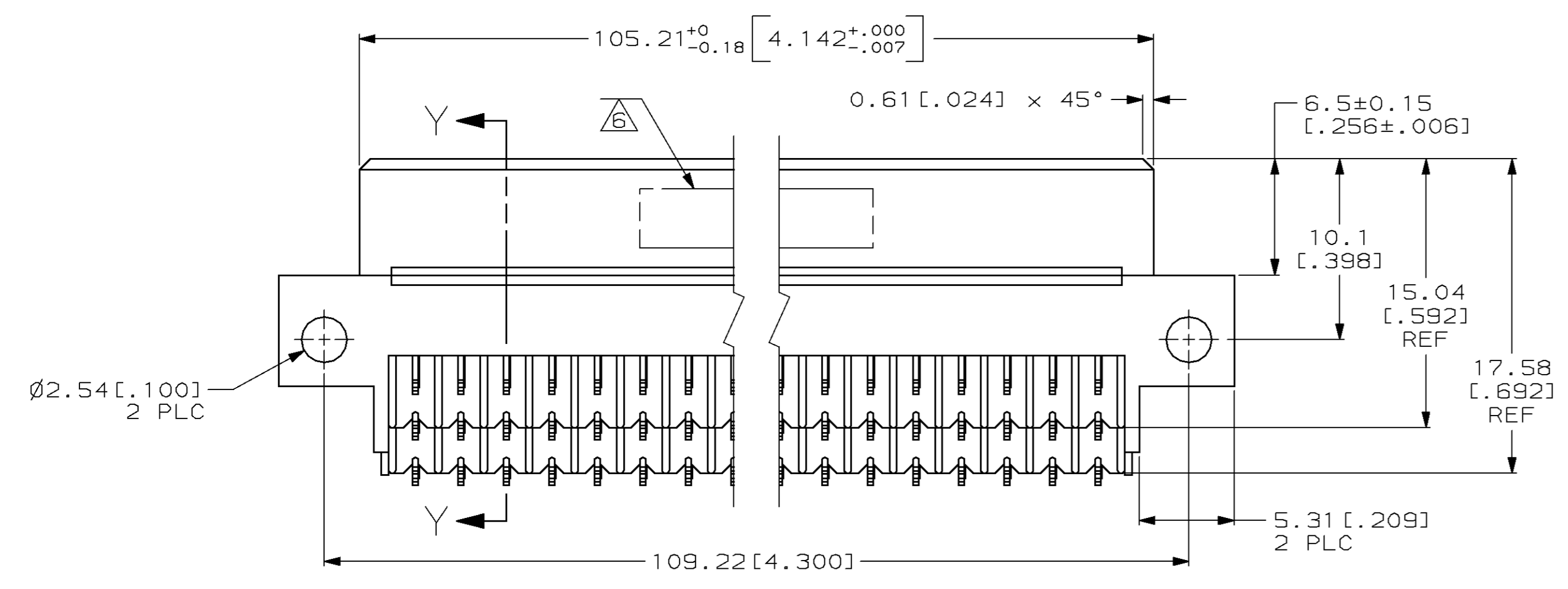

| NOTES                  | POSITIONS LOADED | C | B | A | NO. OF LOADED POSITION | ASSY PART NUMBER |
|------------------------|------------------|---|---|---|------------------------|------------------|
| SUPERSEDED BY 650874-4 | 1 THRU 40        | X | X | X | 120                    | 650874-9         |
|                        | 1 THRU 40        | X | X | X | 120                    | 650874-5         |
|                        | 1 THRU 40        | X | X | X | 120                    | 650874-4         |

|   |   |   |   |
|---|---|---|---|
| DO NOT SCALE PRINT. UNLESS SPECIFIED DIMENSIONS IN mm [INCHES] TOLERANCES ON:<br>1. PLC DEC ± -<br>2. PLC DEC ± 0.13 [.005]<br>ANGLES ± - | DR L. BRINER 7/25/90<br>CHK N. DRASHER 12/19/91<br>APPD N. DRASHER 12/19/91<br>MATERIAL APPD K.R. PARMER 12/19/91<br>HOUSING: 2<br>CONTACT: 3<br>FINISH CONTACT: 4, 9, 10 | 7/25/90<br>12/19/91<br>12/19/91<br>12/19/91 | AMP INCORPORATED<br>Harrisburg, Pa. 17105 |
| NAME<br>RECEPTACLE ASSEMBLY, EUROCARD,<br>TYPE R, 120 POSITION  |   | SIZE D<br>00779                             | DRAWING NO<br>650874                      |
| APPLICATION SPEC  | WEIGHT  | SCALE 4:1                                   | SHEET 1 OF 1                              |