

SLR SERIES

Solid-State Relay - Non-Isolated

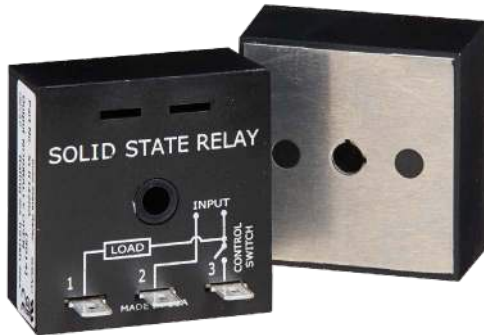

Description

The SLR Series has no isolation between the control switch input and the solid-state output. Select the SLR for applications where the control switch is the same voltage source as the load. Provides the noiseless, reliability and long life of a solid-state relay, without the cost of isolation circuitry. The SLR Series offers random switching and is normally used for inductive loads. When fully insulated female terminals are used on the connection wires, the system meets the requirements for touch-proof connections.

Operation

The solid-state output is located between terminals 1 and 2 and can be ordered as either normally open or normally closed, when voltage is applied and S1 is open. When S1 is closed, the solid-state output between terminals 1 and 2 closes (or opens). If S1 is opened, the solid-state output will open (or close).

Reset: Opening S1 resets the output to its original state. Reset is also accomplished by removing input voltage.

Wiring Diagram

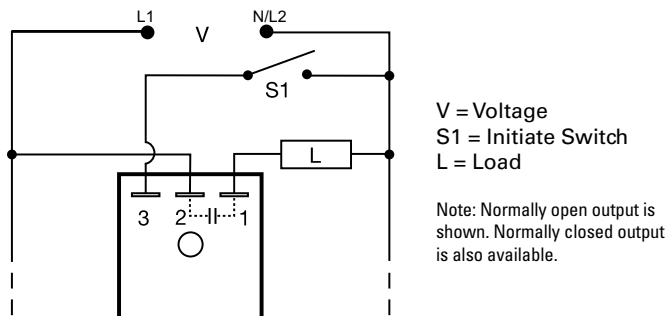

Features & Benefits

FEATURES	BENEFITS
Compact design measures 2 in. (50.8mm) square	Perfect for OEM applications where space is limited
Totally solid state and encapsulated	No moving parts to arc and wear out over time and encapsulated to protect against shock, vibration, and humidity
Up to 20A steady, 200A inrush output rating	Provides direct control of heavy inductive, resistive, or incandescent loads
Metalized mounting surface	Facilitates heat transfer in high current applications

Accessories

P1015-13 (AWG 10/12), **P1015-64** (AWG 14/16), **P1015-14** (AWG 18/22) **Female Quick Connect**
These 0.25 in. (6.35 mm) female terminals are constructed with an insulator barrel to provide strain relief.

P1015-18 Quick Connect to Screw Adapter
Screw adapter terminal designed for use with all modules with 0.25 in. (6.35 mm) male quick connect terminals.

Ordering Information

MODEL	SWITCHING	INPUT VOLTAGE	OUTPUT RATING	OUTPUT FORM
SLR1420A	Random	120VAC	20A	Normally open
SLR1610A	Random	230VAC	10A	Normally open

If you don't find the part you need, call us for a custom product 800-843-8848

SLR SERIES

Specifications

Output (Contact)

Type	Non-isolated solid state		
Form	SPST, NO or NC		
Voltage	24, 120, or 230VAC		
Tolerance	±20%		
Ratings	Steady State	Inrush*	Output Device
	1A	10A	SCR & Bridge Rectifier
	6 A	60A	Triac
	10A	100A	Triac
	20A	200A	Triac

Minimum Load Current	≅ 50mA
Voltage Drop (at Rated Current)	≅ 2.0V - 6, 10, & 20A units; ≅ 2.5V - 1A units
Leakage Current (Open State)	≤ 5mA
Initiate Switch Voltage	Same as the output voltage
Power Consumption	≤ 0.5W

Protection

Circuitry	Encapsulated
Dielectric Breakdown	≥ 2000V RMS terminals to mounting surface
Insulation Resistance	≥ 100MΩ

Mechanical

Mounting*	Surface mount with one #10 (M5 x 0.8) screw
Dimensions	H 50.8 mm (2.0"); W 50.8 mm (2.0"); D 38.4 mm (1.51")
Termination	0.25 in. (6.35 mm) male quick connect terminals

Environmental

Operating/Storage Temperature	-20° to 60°C / -40° to 85°C
Humidity	95% relative, non-condensing
Weight	1A units: ≅ 2.4 oz (68 g); 6, 10, 20A units: ≅ 3.9 oz (111 g)

*Must be bolted to a metal surface using the included heat sink compound. The maximum mounting surface temperature is 90°C. Inrush: Non-repetitive for 16ms.

Function Diagram

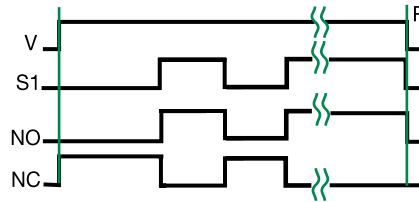

V = Voltage
S1 = Initiate Switch
NO = Normally Open Contact
NC = Normally Closed Contact
R = Reset
— — = Undefined Time