

SF2395H

**1224 MHz
SAW Filter**

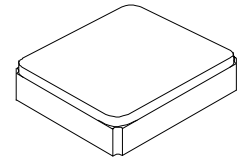

SM2016-4

- **Designed for Front End GPS, Beidou, and Glonass Applications**
- **Steep Rejection**
- **2.0 x 1.6 x 1.0 mm Surface-Mount Case**
- **Complies with Directive 2002/95/EC (RoHS)**
- **Moisture Sensitivity Level: 1**
- **AEC-Q200 Qualified**

Absolute Maximum Ratings

Rating	Value	Units
Input Power Level	+10	dBm
DC Voltage	3	VDC
Operable Temperature Range	-45 to +125	°C
Specification Temperature Range	-40 to +105	°C
Storage Temperature Range	-40 to +85	°C
Moisture Sensitivity Level	1	MSL
Maximum Soldering Profile	265°C for 10 s	

Electrical Characteristics

Characteristic	Sym	NOTE	-40 to +105°C			UNITS
			MIN	TYPICAL	MAX	
Center Frequency	F _c			1224		MHz
Insertion Loss, 1197 to 1249 MHz	IL	3		3.0	3.3	dB
Group Delay Variation 1197 to 1217 MHz 1217 to 1237 MHz 1242 to 1249 MHz				1.4	5	ns
				1.1	5	
				0.7	5	
Attenuation Referenced to 0 dB:						
880 to 920 MHz			22	27		dB
1710 to 1785 MHz			23	28		
1850 to 1910 MHz			24	29		
1920 to 1980 MHz			26	31		
2400 to 2500 MHz			30	37		
Temperature Coefficient of Frequency				-80		ppm/°C
Source impedance	Z _S			50		Ω
Load impedance	Z _L			50		Ω

Standard Reel Quantity	Reel Size: 7 inch	2000 Pieces/Reel
	Reel size: 13 inch	10,000 Pieces/Reel
Single-ended Input / Output Impedance Match	No matching network required for operation at 50 ohms	
Package Size	SM2016-4	
Lid Symbolization (Y=year, W=week)	A6, <u>YW</u>	



CAUTION: Electrostatic Sensitive Device. Observe precautions for handling.

NOTES:

1. The design, manufacturing process, and specifications of this device are subject to change.
2. US or International patents may apply.
3. Maximum insertion loss = 3.0 dB @ 85°C

Electrical Connections

Connection	Terminals
Input	1
Output	3
Ground	All others

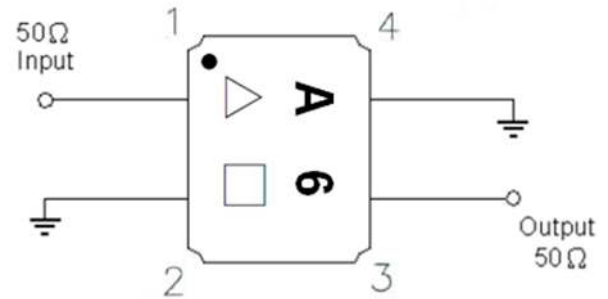

Frequency Characteristics

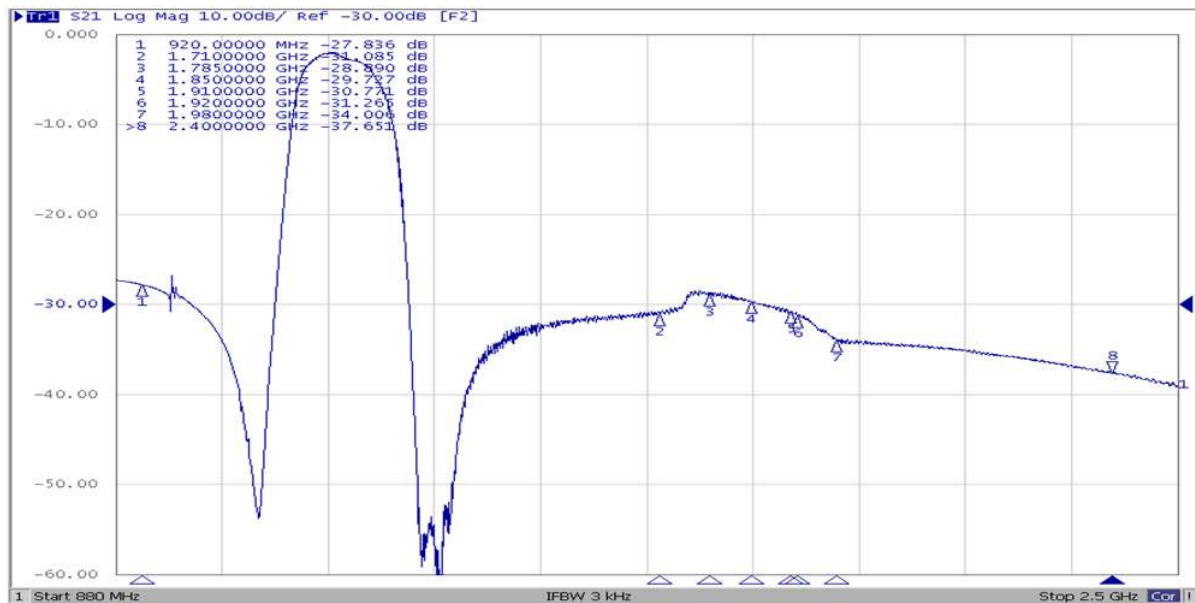
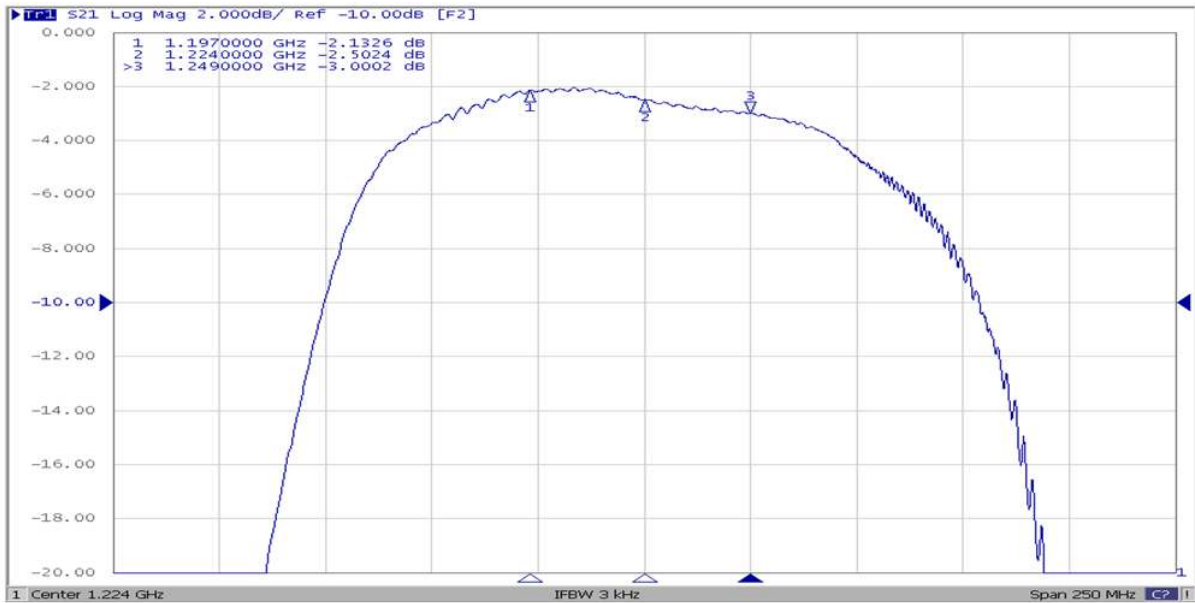

Group Delay

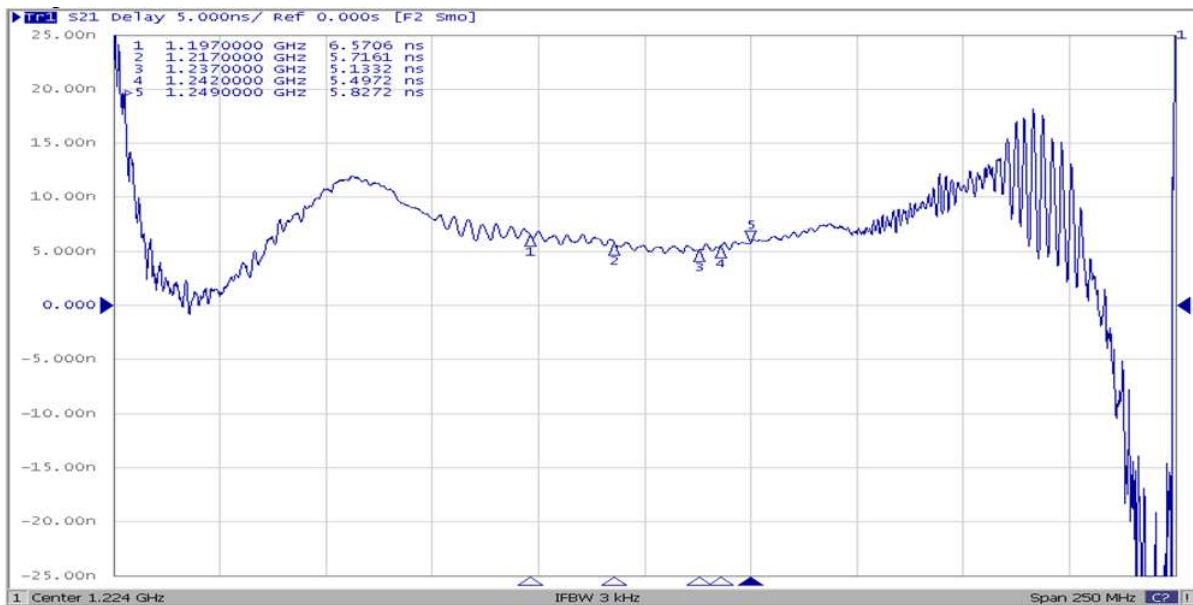
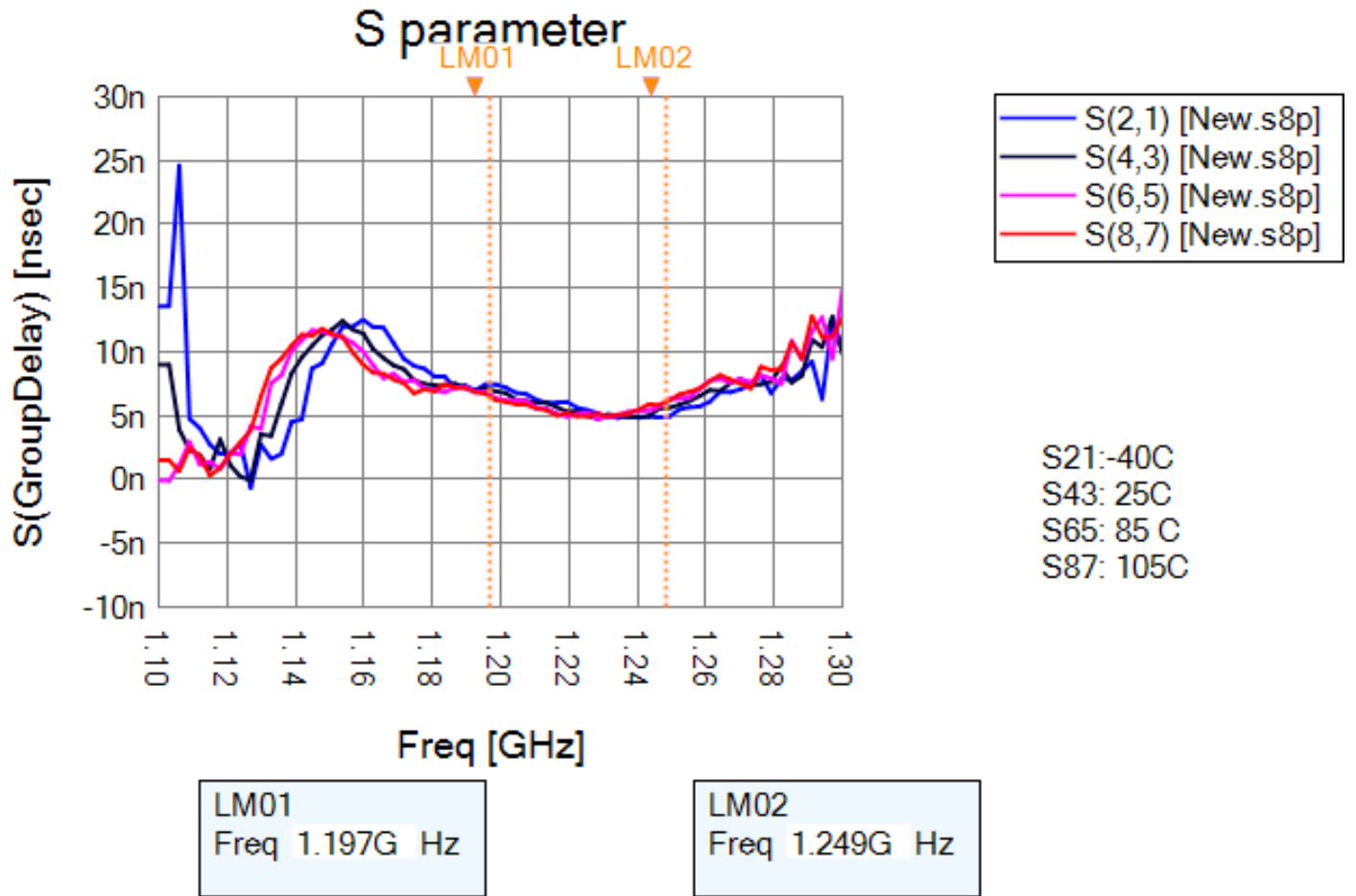

SM2016-4 Case

4-Terminal Ceramic Surface-Mount Case

2.0 X 1.6 mm Nominal Footprint

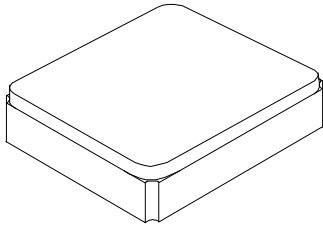

PCB PAD LAYOUT

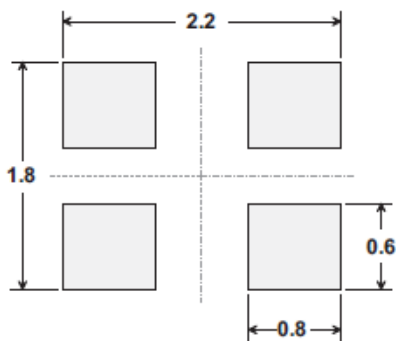

Dimensions in mm
All pads have the same dimensions

Case Dimensions

Dimension	mm		
	Min	Nom	Max
A	1.58	1.65	1.72
B	1.98	2.05	2.12
C	0.44	0.52	0.58
D		0.60	
E		0.425	
F		0.425	
G		0.625	
H		0.10	

Materials	
Solder Pad Plating	0.3 to 1.0 μm Gold over 1.27 to 8.89 μm Nickel
Lid Plating	2.0 to 3.0 μm Nickel
Body	Al_2O_3 Ceramic

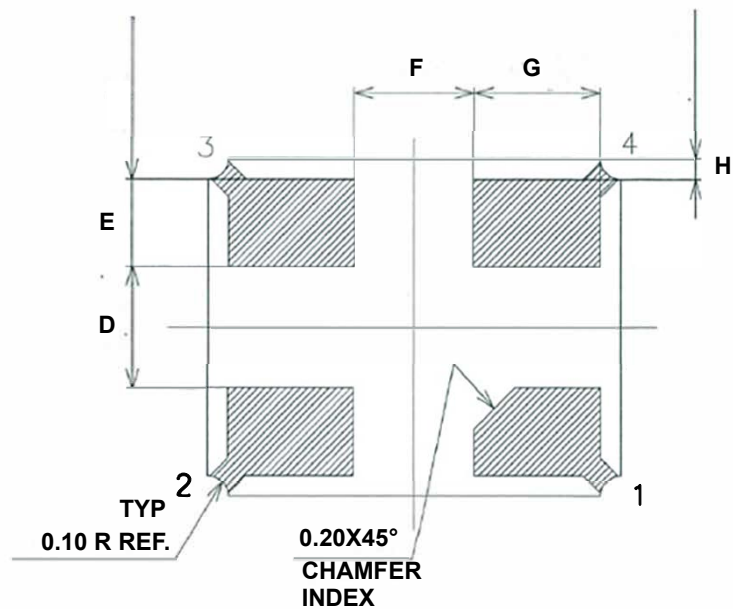
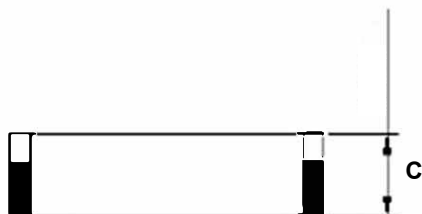
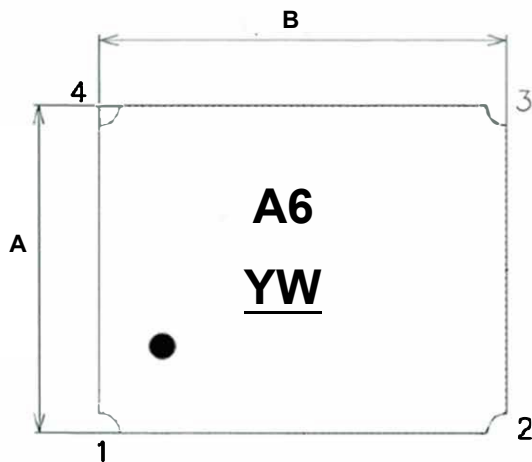

Tape and Reel Standard per ANSI/EIA-481

Reel Dimensions

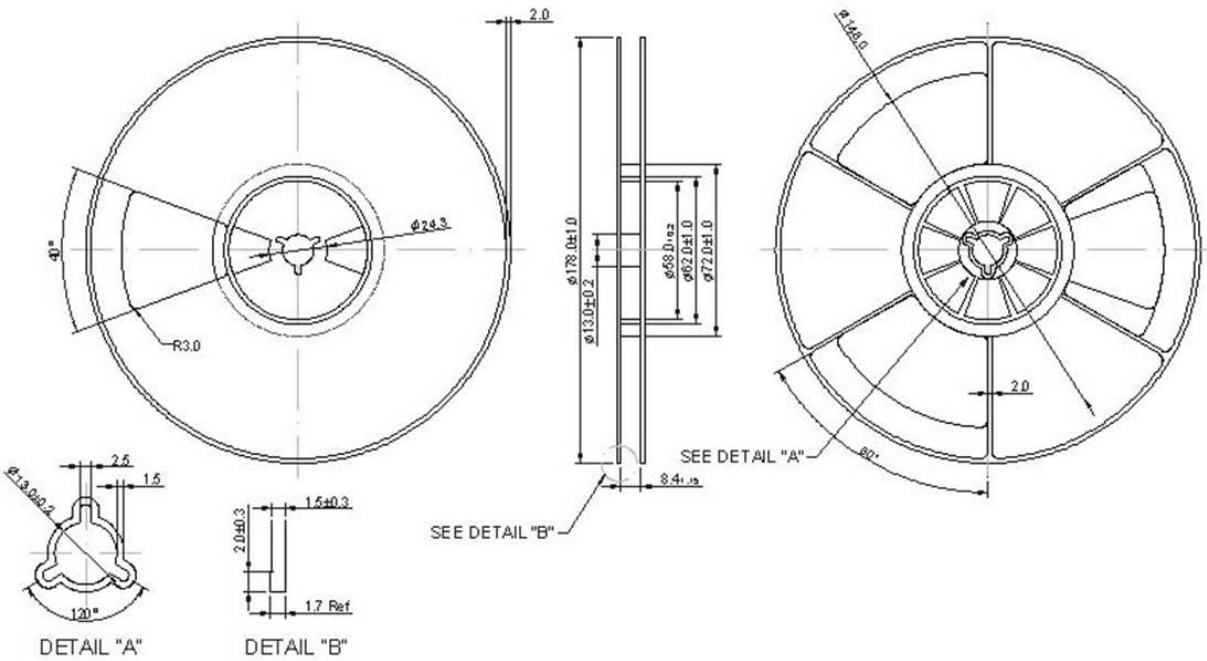

Tape Dimensions

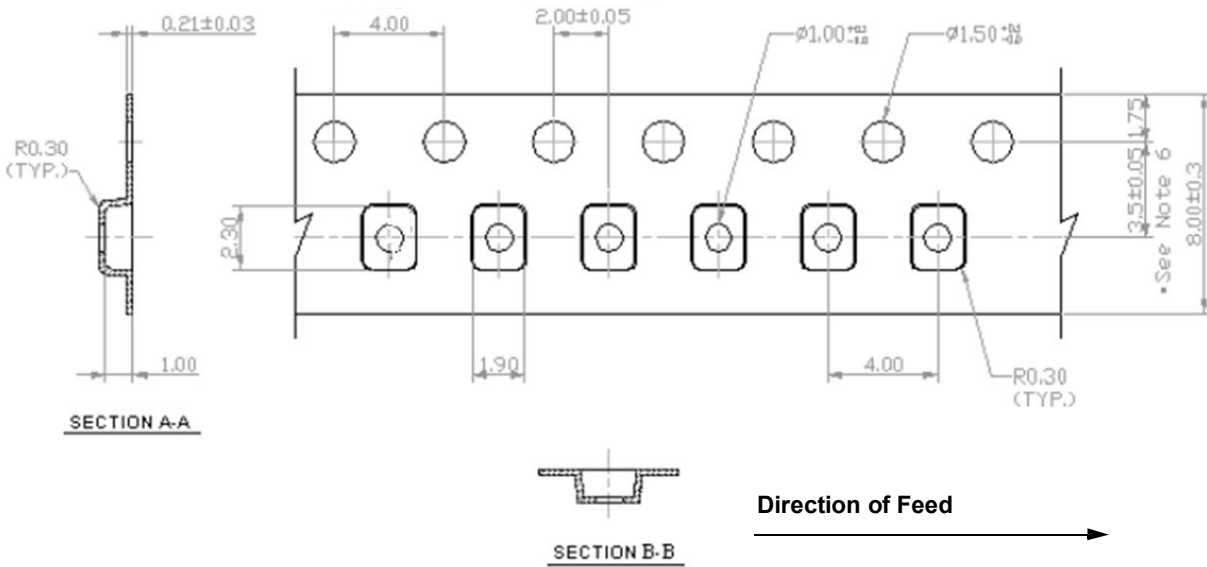

Recommended Reflow Profile

1. Preheating shall be fixed at 150~180°C for 60~90 seconds.
2. Ascending time to preheating temperature 150°C shall be 30 seconds min.
3. Heating shall be fixed at 220°C for 50~80 seconds and at 260°C +0/-5°C peak (10 seconds).
4. Time: 5 times maximum.

