

FEATURES

- Ultra Low Quiescent Power Dual output 3+1 phase PWM Controller
- Intel® VR12 Rev 1.7, VR12.5 Rev 1.5, IMVP8 Rev 1.2, AMD SVID2, and Memory VR modes
- Switching frequency from 194KHz to 2MHz per phase in 56 steps
- IR Efficiency Shaping Features including Dynamic Phase Control and Automatic Power State Switching
- Programmable 1-phase or 2-phase operation for Light Loads and Active Diode Emulation for very Light Loads
- IR Adaptive Transient Algorithm (ATA) on both loops minimizes output bulk capacitors and system cost
- Auto-Phase Detection with PID Coefficient auto-scaling
- Fault Protection: OVP, UVP, OCP, OTP, CAT_FLT
- I2C/SMBus/PMBus system interface for reporting of Temperature, Voltage, Current & Power telemetry for both loops
- Multiple Time Programming (MTP) with integrated charge pump for easy non-volatile programming
- Compatible with 3.3V tri-state drivers
- +3.3V supply voltage; -40°C to 85°C ambient operation; -40°C to 125°C junction
- Pb-Free, RoHS, 5x5mm 40-pin, 0.4mm pitch QFN

APPLICATIONS

- Intel® VR12, VR12.5 and IMVP8 (overclocking only), AMD SVI2 based systems
- Servers and High End Desktop CPU VRs
- High Performance Graphics Processors, Memory VR

DESCRIPTION

The IR35204 is a dual-loop digital multi-phase buck controller designed for CPU voltage regulation, and is fully compliant with Intel®, VR12 Rev 1.7, VR12.5 Rev 1.5, IMVP8² Rev 1.2, and AMD SVI2 REV 1.06 specifications.

The IR35204 includes IR's Efficiency Shaping Technology to deliver exceptional efficiency at minimum cost across the entire load range. IR's Dynamic Phase Control adds/drops phases based upon load current. The IR35204 can be configured to enter 1 or 2-phase PS1 operation and active diode emulation mode automatically or by command.

IR's unique Adaptive Transient Algorithm (ATA), based on proprietary non-linear digital PWM algorithms, minimizes output bulk capacitors.

IR35204 has 127 possible address values for both the PMBus and I2C bus interfaces. The device configuration can be easily defined using the IR PowIRCenter GUI, and is stored in the on-chip Non-Volatile Memory (NVM). This reduces external components and minimizes the package size.

The IR35204 provides extensive OVP, UVP, OCP, OTP & CAT_FLT fault protection, and includes thermistor based temperature sensing or per phase temperature reporting when using the IR powIRstage. The controller is designed to work with either R_{dson} current sense PowIRstages or with DCR current sense.

The IR35204 also includes numerous VR design simplifying and differentiating features, like register diagnostics, which enable fast time-to-market.

ORDERING INFORMATION

Base Part Number	Package Type	Standard Pack		Orderable Part Number
		Form	Quantity	
IR35204	40-pin, QFN 5 mm x 5 mm	Tape and Reel	3000	IR35204MxxyyTRP ¹
IR35204	40-pin, QFN 5 mm x 5 mm	Tape and Reel	3000	IR35204MTRPBF
IR35204	40-pin, QFN 5 mm x 5 mm	Tray	4900	IR35204MTYPBF

Notes:

1. Customer Specific Configuration File, where xx = Customer ID and yy = Configuration File (Codes assigned by IR Marketing).
2. IR35204 is not intended for application where ultra low power PS4 shutdown functionality is required.

ORDERING INFORMATION

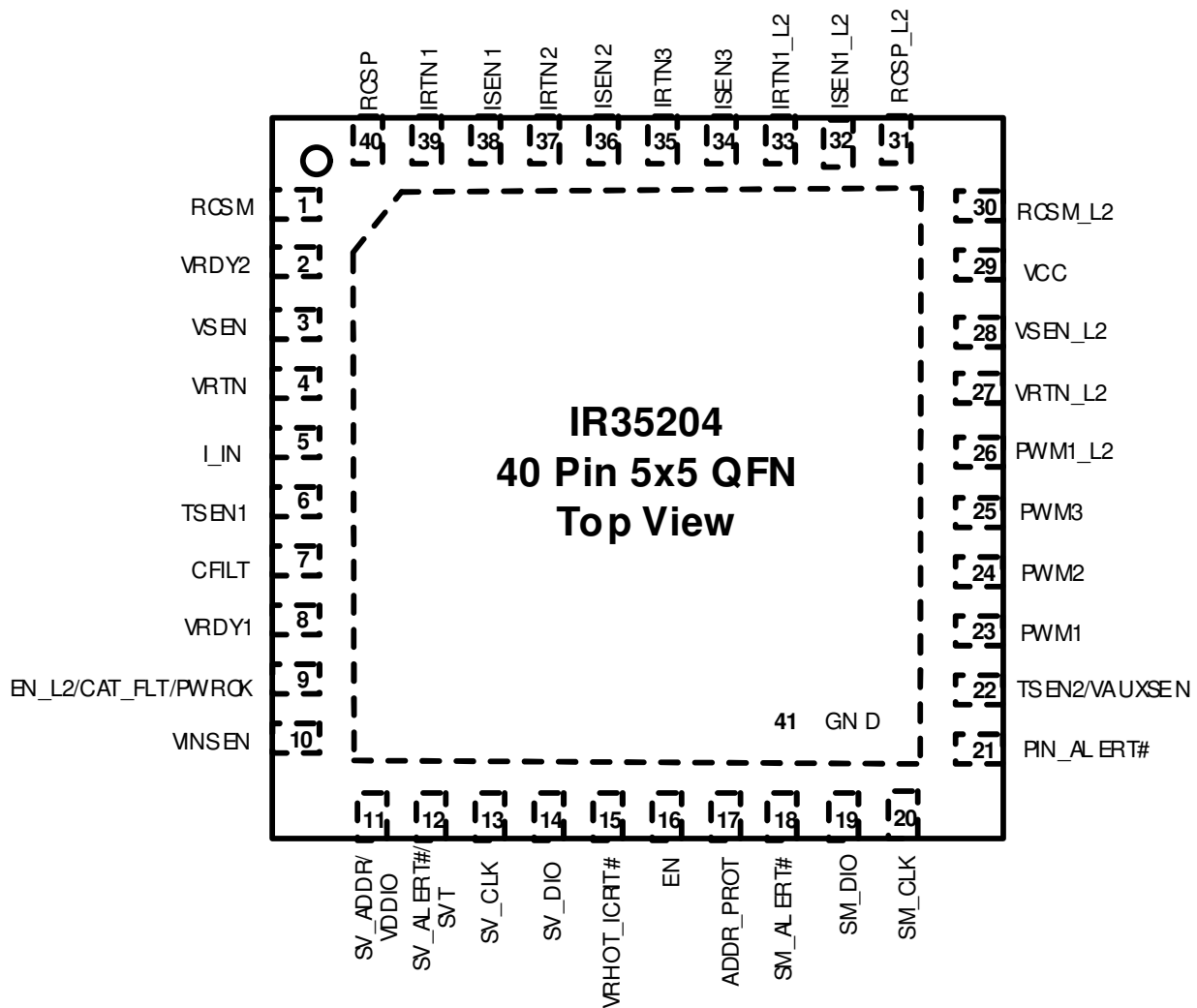
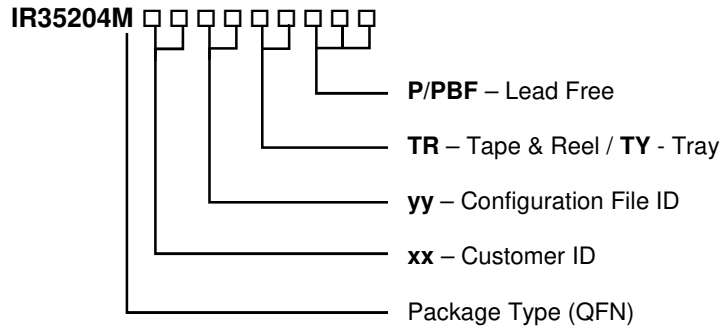

Figure 1: IR35204 Pin Diagram