

Bluetooth Low Energy(BLE) Module BT600 Series

Ver 1.21, Oct. 2016

BLE Single Mode Module BT600 Series

Specifications:

- Processor: Nordic nRF51822
- Bluetooth: Bluetooth Low Energy
- Frequency: 2.402~2.480 GHz
- Receiver Sensitivity: -91 dBm (typical)
- Transmit Power 0 dBm +/- 1dB
- Interface UART
- Protocol AT Commands
- Applications iOS and Android apps are available
- Operation voltage 1.8V-3.6V
- Line of Sight Range 20m (60 feet) to 50m (150 feet)
- Encryption 128 bit using CCM encryption
- Dimensions 20mmX12mmX2mm
- Operation -25°C to +75°C
- Storage -40°C to +85°C

Applications

- Smart appliances
- Wearable device
- Medical devices
- Health management devices
- Computer peripherals
- Other Bluetooth applications

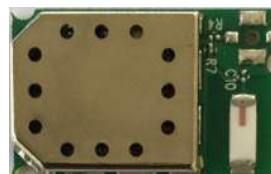

Model Summaries

module	BT600I	BT600I-12	BT600I-23	BT600E
SoC	nRF51822 QFAB	nRF51822 QFAA	nRF51822 QFAC	nRF51822
Flash/RAM	128KB/16KB	256KB/16KB	256KB/32KB	128KB/16KB
Bluetooth range	30 meters	30 meters	30 meters	50 meters
BT Antenna	chip	chip	chip	external
FCC ID	X8WBT600E	X8WBT600E	X8WBT600E	X8WBT600E
Canada IC ID	4100A-BT600E	4100A-BT600E	4100A-BT600E	
Japan	201-163100	201-163100	201-163100	
Europe	Approved	Approved	Approved	
Australia	Approved	Approved	Approved	



Table Of Contents

1. Introduction	3
1.1. Standalone Mode	3
2. Product Overview	4
2.1. Nordic nRF51822 Block Diagram.....	4
2.2. Photos	5
2.3. Mechanical Drawings	5
2.3.1. Physical Dimensions	5
2.4. Pin Assignments of BT600	6
2.5. Pin Functions	7
3. Operation Parameters.....	9
4. AT Commands	9
4.1. Brief description of AT commands.....	9
4.2. Command mode.....	10
4.3. Data Mode.....	12
5. Reference Applications	12
5.1. Suggestion for Battery Power Application	12
6. BT600 Evaluation Board	13
6.1. Communicating with a PC	13
6.2. Communicating with a Host Processor	13
6.3. Evaluation Board Schematics	14
7. Miscellaneous	15
8. Contact Us	15

1. Introduction

BT600 series Bluetooth single mode module uses Nordic nRF51822 Bluetooth Low Energy (BLE) chip. Three antenna options are offered:

- BT600I with a chip antenna on module, line of sight range is 30 meters or 90 feet.
- BT600E, an external antenna is required. Line of sight range is 50 meters or 150 feet when used with recommended antenna.
- EV-BT600. Development board for BT600 modules. A PC or a host processor can communicate with BT600 through an UART port. All IO pins are available at connectors.

A host processor can set BT600 to command and data mode by setting an I/O pin to high and low, respectively. When using with a PC, a jumper is used to set the BT600 IO pin. When in data mode, the host processor communicates with a smartphone, a computer, or other electronic equipment through this BT module.

1.1. Standalone Mode

BT600 can operate in standalone mode – without a host processor. A 32 bit ARM Cortex™ M0 processor with 128 KB of flash memories are built-in. Development tools are available from Nordic and other 3rd parties. BT600 dimensions and pin assignments are the same as some modules from other manufacturers. Programming tools are commercially available to reprogram module for standalone operation.

2. Product Overview

2.1. Nordic nRF51822 Block Diagram

The following is a block diagram of Nordic nRF51822 Bluetooth Low Energy (BLE) IC.

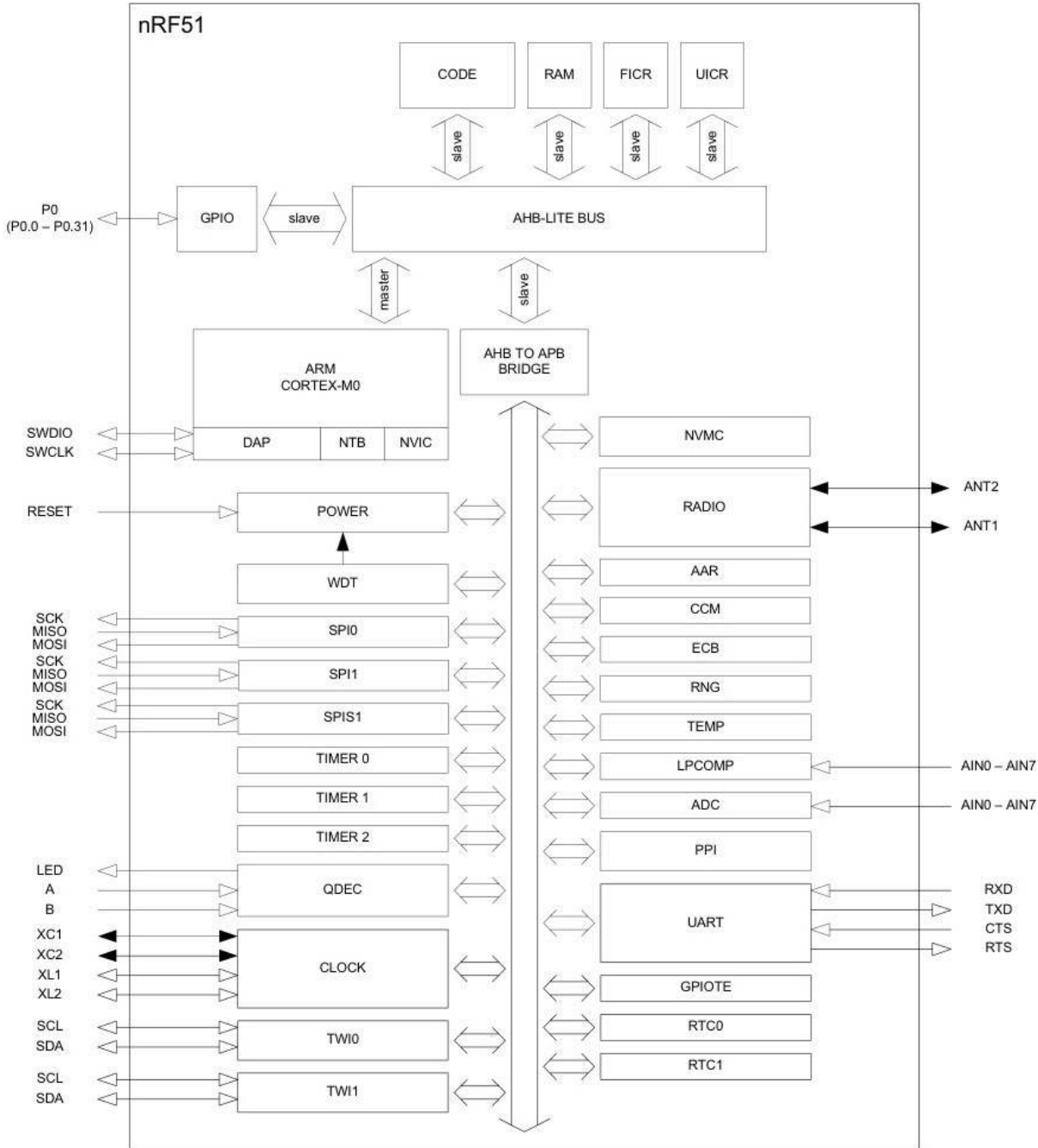

Figure 1 Block diagram of nRF51822

2.2. Photos

The followings are pictures of BT600 module with an EMI shield on and without EMI shield.

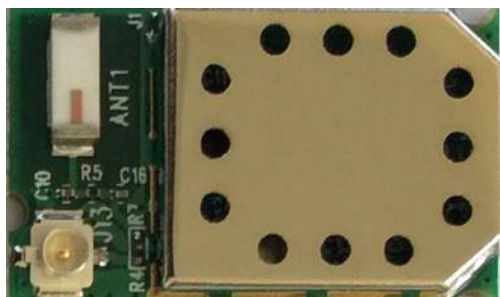

Figure 2 BT600 with an EMI shield

2.3. Mechanical Drawings

2.3.1. Physical Dimensions

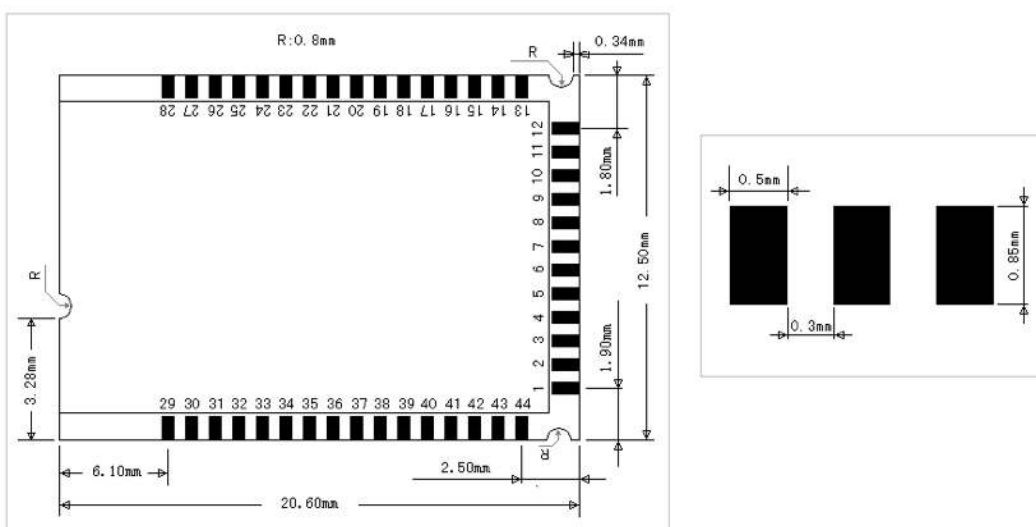

Figure 3 BT600 mechanical drawings



Bluetooth Low Energy(BLE) Module BT600 Series

Ver 1.21, Oct. 2016

2.4. Pin Assignments of BT600

BT600

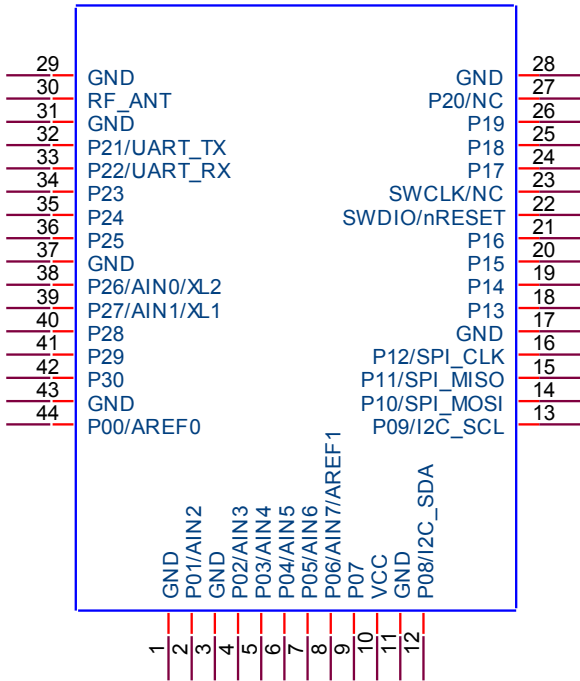

2.5. Pin Functions

Pin	Pin name	Descriptions	Note
1	GND	Ground	
2	P01, AIN2	General purpose I/O pin, ADC/LPCOMP input 2	
3	GND	Ground	
4	P02, AIN3	General purpose I/O pin, ADC/LPCOMP input 3	
5	P03, AIN4	General purpose I/O pin, ADC/LPCOMP input 4	
6	P04, AIN5	General purpose I/O pin, ADC/LPCOMP input 5	
7	P05, AIN6	General purpose I/O pin, ADC/LPCOMP input 6	
8	P06, AIN7, AREF1	General purpose I/O pin, ADC/LPCOMP input 7, ADC/LPCOMP reference input 1	
9	P07	General purpose I/O pin	
10	VCC	DC power input, 1.8V to 3.6V	
11	GND	Ground	
12	P08, I2C SDA	General purpose I/O pin, I2C data pin	
13	P09, I2CSCL	General purpose I/O pin, I2C clock pin	
14	P10, SPI MOSI	General purpose I/O pin, SPI MOSI pin	
15	P11, SPI MISO	General purpose I/O pin, SPI MISO pin	
16	P12, SPI CLK	General purpose I/O pin, SPI clock pin	
17	GND	Ground	
18	P13	General purpose I/O pin	
19	P14	General purpose I/O pin	
20	P15	General purpose I/O pin	
21	P16	General purpose I/O pin	
22	SWDIO	System reset (active low). Also hardware debug and flash programming I/O.	
23	SWCLK	Hardware debug and flash programming I/O.	
24	P17	General purpose I/O pin	
25	P18	General purpose I/O pin	
26	P19	General purpose I/O pin	
27	P20	General purpose I/O pin	
28	GND	Ground	
29	GND	Ground	
30	RF_ANT	Connection to external antenna	
31	GND	Ground	
32	P21, UART TX	General purpose I/O pin, UART TX pin	

Bluetooth Low Energy(BLE) Module BT600 Series

Ver 1.21, Oct. 2016

33	P22, UART RX	General purpose I/O pin, UART RX pin	
34	P23, Mode	General purpose I/O pin, 1=command; 0=data	1
35	P24	General purpose I/O pin,	
36	P25	General purpose I/O pin	
37	GND	Ground	
38	P26, AIN0, XL2	General purpose I/O pin, ADC/LPCOMP input 0, Connection for 32.768 kHz crystal	
39	P27, AIN1, XL1	General purpose I/O pin, ADC/LPCOMP input 1, Connection for 32.768 kHz crystal	
40	P28	General purpose I/O pin	
41	P29	General purpose I/O pin	
42	P30	General purpose I/O pin	
43	GND	Ground	
44	P00, AREF0	General purpose I/O pin, ADC/LPCOMP reference input 0	

1. Connect P23 to high for command mode and to low for data mode.

3. Operation Parameters

Wireless	Features	Specifications
	Bluetooth	V4.0 -Single Mode
	Frequency	2.402 - 2.480 GHz
	Max. Transmit Power	-0.12 dBm
	Receiver Sensitivity	-91 dBm, typical
	Whisper Mode	Down to -55 dBm, transmit
	Link Budget	95 dB @ 1Mbps
	Raw Data Rate	1 Mbps over the air
Host Interfaces	Total	28 lines, multi function
	UART	TX, RX
		Default, 9600, N, 8, 1.
		Baud rate from 1200 to 921600bit
	GPIO	Up to 28 lines
	SPI	3 lines
	I2C	2 lines
	ADC	6 lines
Control Protocol		AT Command Sets
Encryption	AES Advanced Encryption Standard	128 bit using CCM encryption
Supply voltage		1.8V - 3.6V
Power Consumption	current	Idle: 3.5 uA
Dimensions /尺寸	27mmX13mmX2mm	
Environmental	Operating	-25°C to +75°C
	Storage	-40°C to +85°C
BT600P	PCB trace antenna	Line-of-sight range, 20 meters or 60 feet.
BT600I	Internal antenna	Line-of-sight range, 30 meters or 90 feet.
BT600E	External antenna	Line-of-sight range, 50 meters or 150 feet.

4. AT Commands

4.1. Brief description of AT commands

- Each command line consists of a prefix, a body and a terminator.
- All command lines begin with the prefix AT (ASCII 065, 084) or at (ASCII 097, 116).
- The body is a string of characters in the ASCII range 032-255. Control characters other than <CR> (carriage return; ASCII 013) and <BS> (back space; ASCII 008) in a command line are ignored.
- The terminator is <CR>.

Bluetooth Low Energy(BLE) Module BT600 Series

Ver 1.21, Oct. 2016

- There is no distinction between upper-case and lower-case characters. A command line can have a maximum length of 80 characters. It is automatically discarded if the input is longer. Corrections are made
- AT command is case-insensitive, following /r/n for end code.
- The default baud rate is 9600 one stop bit and no parity

4.2. Command mode

When P23 (pin 34 of BT600) is pulled high, it is set to AT command mode. In AT command mode, the host processor communicates with the processor on BT600.

<i>Command</i>	<i>Response</i>	<i>Parameter</i>	<i>example</i>
AT	OK or FAIL	none	AT/r/n OK/r/n
AT+RESET	OK or FAIL	none	AT+RESET/r/n OK/r/n
AT+VERSION?	+VERSION:<param> OK	Software version number	AT+VERSION?/r/n +VERSION140804 OK/ r/n
AT+NAME?	+NAME:<param> OK	Device name	AT+NAME?/r/n +NAME:EZPro OK/r/n
AT+NAME=<param>	OK or FAIL	Device name	AT+NAME=Fanstel/r/n Or AT_Name="Fanstel"/r/n OK/r/n
AT+UART?	+UART:<param>,<param2>,<param3> > OK	Baud rate, Stop bit, Parity	AT+UART?/r/n +UART:115200,1,0 OK/r/n
AT+UART=<parm>	+UART:<parm>	Baud rate	AT+UART=115200/r/n +UART:115200,1,0 OK/r/n 1200 2400 4800 9600 default 19200



Bluetooth Low Energy(BLE) Module BT600 Series

Ver 1.21, Oct. 2016

			38400 57600 115200 230400 460800 921600 1000000
AT+ADDR?	+ADDR:<param> OK	Device MAC address	AT+ADDR?/r/n +ADDR:abb5:cd: 604ace OK/r/n
AT+REGISTER	OK or FAIL	none	AT+REGISTER/r/n OK/r/n
AT+QUITREGISTER	OK or FAIL	none	AT+QUITREGISTER/r/n OK/r/n
AT+RX?	+Name:<parm> +UART:<parm> +ADDR:<parm>	none	AT+RX?/r/n +NAME:EZPro/r/n +UART:115200,1,1/r/n +ADDR: abb5:cd: 604ace/r/n
AT+DEFAULT	OK or FAIL	none	AT+DEFAULT/r/n OK/r/n
AT_RFPW?	+RFPW:parm	+4~-8	AT+RFPW?/r/n +RFPW:-4 OK/r/n 0:+4 1:+0 default 2:-4 3:-8
AT_RFPW=<parm>	OK or FAIL	+4~-8	AT+RFPW= 1/r/n OK/r/n 0:+4 1:+0 2:-4 3:-8

Bluetooth Low Energy(BLE) Module BT600 Series

Ver 1.21, Oct. 2016

AT +PIO=<param><param1>	OK or FAIL	P00-P05 1=High , 0=low	AT+PIO=05, 0\r\n OK/r/n
AT+PIS=<param><param1>	OK or FAIL	P00-P05 1=output, 0=input	AT+PIS=05, 1\r\n OK/r/n

4.3. Data Mode

When P23 (pin 34 of BT600) is pulled low, it is set to data mode. In data model, BT600 provides transparent data transfer between the host processor and a remote device, for example, a smartphone.

5. Reference Applications

5.1. Suggestion for Battery Power Application

Standby current consumption is important for battery-powered product. We suggest adding a 32.768 kHz crystal and 2 capacitors as in the following figure. The 16MHz or 32MHz main clock won't be active at idle state to save power.

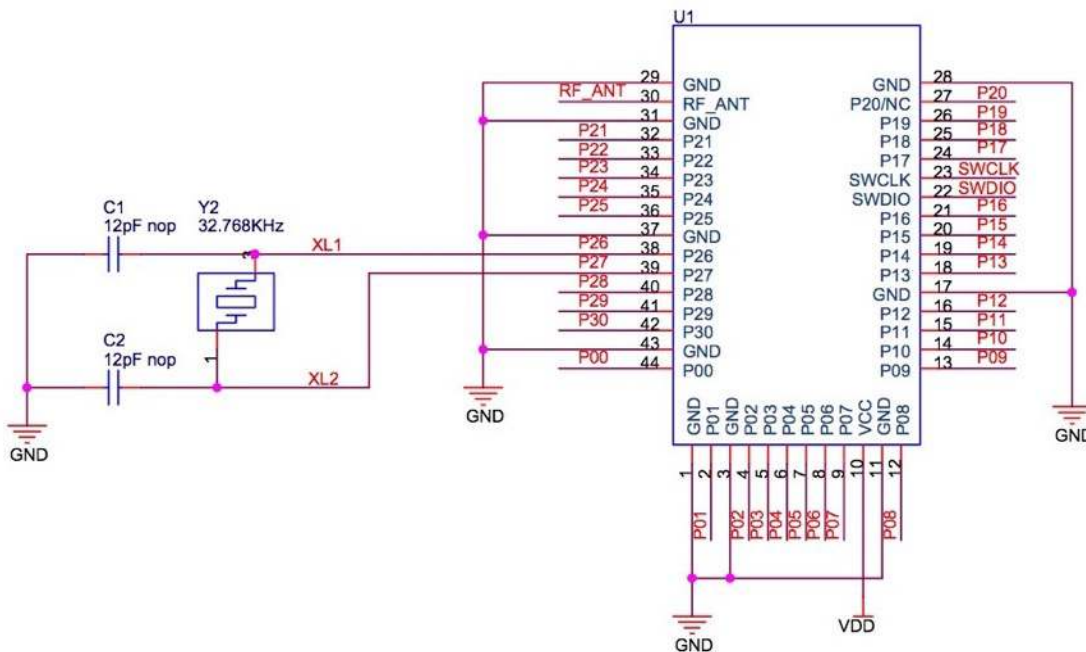

6. BT600 Evaluation Board

6.1. Communicating with a PC

A quick and easy way to evaluate BT600 is to use a PC as the host processor. Connect the development board DVB-BT600 to a PC with an USB cable. Then,

- Remove jumper JP1, BT600 is set to command mode. PC will communicate with BT600.
- Install jumper JP1, BT600 is set to data mode. PC will communicate with a remote device through BT600 Bluetooth wireless connection.

Docklight is a testing, analysis and simulation tool for serial communication protocols (RS232, RS485/422 and others). It allows you to monitor the communication between two serial devices or to test the serial communication of a single device. Docklight significantly increases productivity in a broad range of industries, including automation and control, communications, automotive, equipment manufacturers, and embedded / consumer products. Docklight is easy to use and runs on almost any standard PC using Windows 8, Windows 7, Windows Vista or Windows XP operating system.

Docklight software can be downloaded from the following:

http://www.docklight.de/download_en.htm

6.2. Communicating with a Host Processor

All IO pins of nRF51822 are available at connectors CON1, CON2, CON3, and CON4. To communicate with a host processor, you need to connect:

- RX pin of host processor to P21, TX pin of BT600 UART.
- TX pin of host processor to P22, RX pin of BT600 UART.
- An IO pin to P23 of BT600, set high for command mode and set low for data mode.
- Ground.

Bluetooth Low Energy(BLE) Module BT600 Series

Ver 1.21, Oct. 2016

6.3. Evaluation Board Schematics

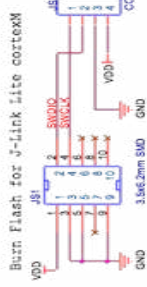
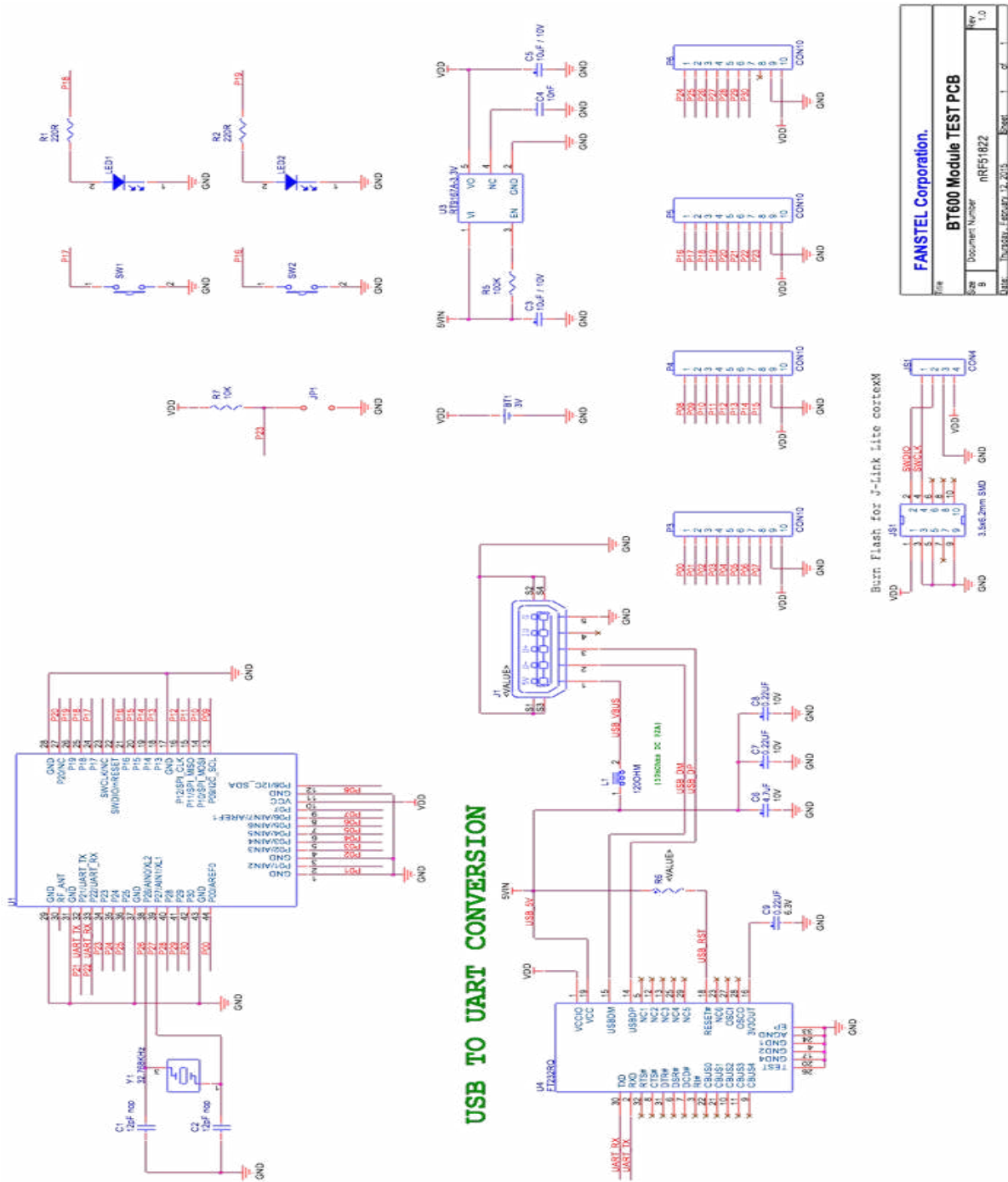

File		BT600..._EPC02_12_2013..._Board	
Documen Number		nRFS 1622	
Rev	1.0		

USB TO UART CONVERSION

7. Miscellaneous

- **DON'T USE A MODULE WITH INTERNAL ANTENNA INSIDE A METAL CASE.**
- **USE A MODULE WITH EXTERNAL ANTENNA INSIDE A METAL CASE. ANTENNA MUST BE OUTSIDE OF A METAL CASE.**
- **FOR PCB LAYOUT:**
 - **AVOID RUNNING ANY SIGNAL LINE BELOW MODULE WHENEVER POSSIBLE,**
 - **NO GROUND PLANE BELOW ANTENNA,**
 - **IF POSSIBLE, CUT-OFF THE PORTION OF MAIN BOARD PCB BELOW ANTENNA.**
- **CONNECT MODULE GROUND TO BATTERY GROUND.**

8. Contact Us

United States:

Fanstel Corp.
7466 E. Monte Cristo Ave. Scottsdale AZ 85260
Tel. 1 480-948-4928
Fax. 1-480-948-5459
Email: info@fanstel.com
Website: www.fanstel.com

Taiwan:

Fanstel Corp.
10F-10, 79 Xintai Wu Road
Xizhu, New Taipei City, Taiwan 22101
泛世公司
臺灣省新北市汐止區新臺五路79號10樓之10, 22101
Tel. 886-2-2698-9328
Fax. 886-2-2698-4813
Email: info@fanstel.com
Website: www.fanstel.com

China:

Fanstel Technologies Corp.
11 Jiale Street
Ping-Dih, Long-Gang, Shen Zhen, GD 518117
泛世康科技(深圳)有限公司
廣東省深圳市龍崗區坪地鎮佳樂街11號
Tel. 86-755-8409-0928
Fax. 86-755-8409-0973
QQ. 3076221086
Email: info@fanstel.com
Website: www.fanstel.com