



Electrical specifications

Center frequency: 1402.5 MHz
1 dB Bandwidth: 1390-1415 MHz
Insertion loss @CF: ≤ 1.25 dB
Rejection 1: ≥ 20 dB@1425 MHz
Rejection 2: ≥ 20 dB@1380 MHz
Rejection 3: ≥ 30 dB@1435 MHz
Rejection 4: ≥ 30 dB@1370 MHz
Power handling: 5 Watts

Mechanical

Mounting Method: 2-56 Threaded Mounting Holes
Connector Type: SMA Female
Dimensions: 2.42" X 1.77" X 1.65" in

Environmental

Operating Temperature: -45 to +85° C
Storage Temperature: -55 to +95° C
Shock: 20 G. 11ms
Vibration: 20 G. 5 to 200 MHz

Outline Drawing:

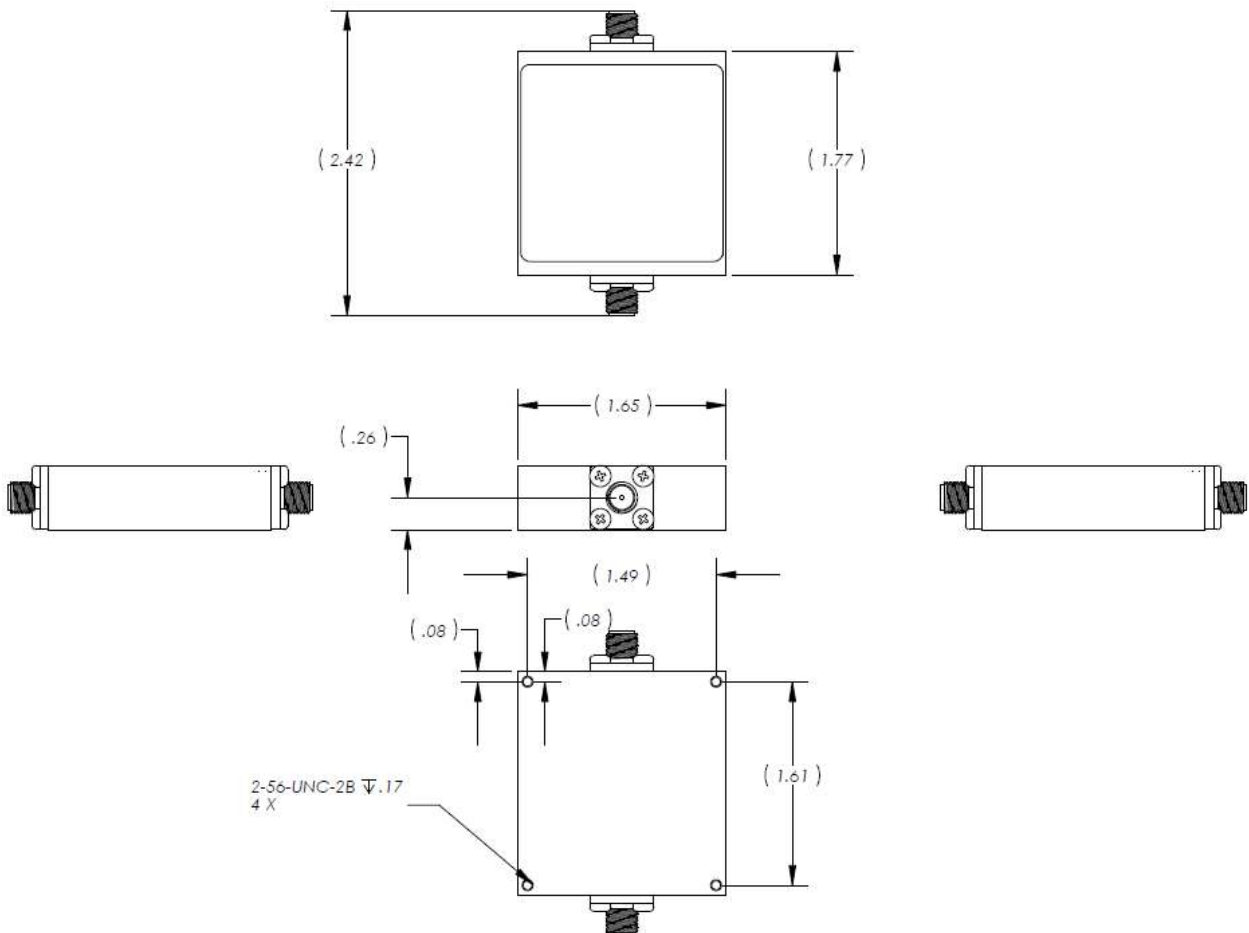



Plot:

