

Long distance ranging Time-of-Flight sensor expansion board based on VL53L1X for STM32 Nucleo

Data brief

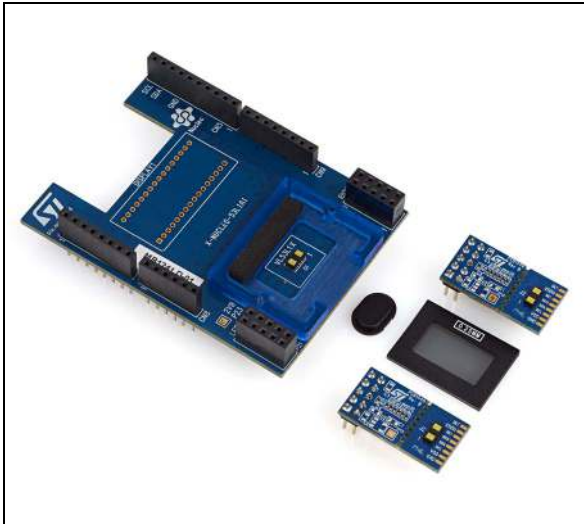

Features

- VL53L1X Time-of-Flight (ToF), long-distance ranging sensor module
- Accurate absolute ranging distance, independent of the reflectance of the target
- 0.25, 0.5 and 1 mm spacers to simulate air gaps
- Two different cover windows
- Two VL53L1X breakout boards
- Compatible with STM32 Nucleo board family
- Equipped with Arduino™ UNO R3 connector
- RoHS compliant
- Full system SW is supplied, including code examples and graphical user interface. All this can be downloaded from the folder "TOOLS AND SOFTWARE, section Ecosystems" on www.st.com/VL53L1X

Description

The X-NUCLEO-53L1A1 is an expansion board for the NUCLEO-F401RE and NUCLEO-L476RG development boards. It provides a complete evaluation kit allowing anyone to learn, evaluate, and develop their applications using the VL53L1X ToF, long-distance ranging sensor technology.

The X-NUCLEO-53L1A1 expansion board is delivered with a cover glass holder in which three different spacers of 0.25, 0.5 and 1 mm height can be fitted below the cover glass to simulate various air gaps.

Two VL53L1X breakout boards can be connected using two 10-pin connectors.

The X-NUCLEO-53L1A1 expansion board is compatible with the STM32 nucleo board family, and with the Arduino UNO R3 connector layout.

Several ST expansion boards can be superposed through the Arduino connectors which allows, for example, the development of VL53L1X applications with Bluetooth or Wi-Fi interfaces.

Table 1. Device summary

Order code	Description
X-NUCLEO-53L1A1	Expansion board for STM32 nucleo board family



1 Block diagram

Figure 1 describes the X-NUCLEO-53L1A1 expansion board features.

Figure 1. X-NUCLEO-53L1A1 circuit diagram

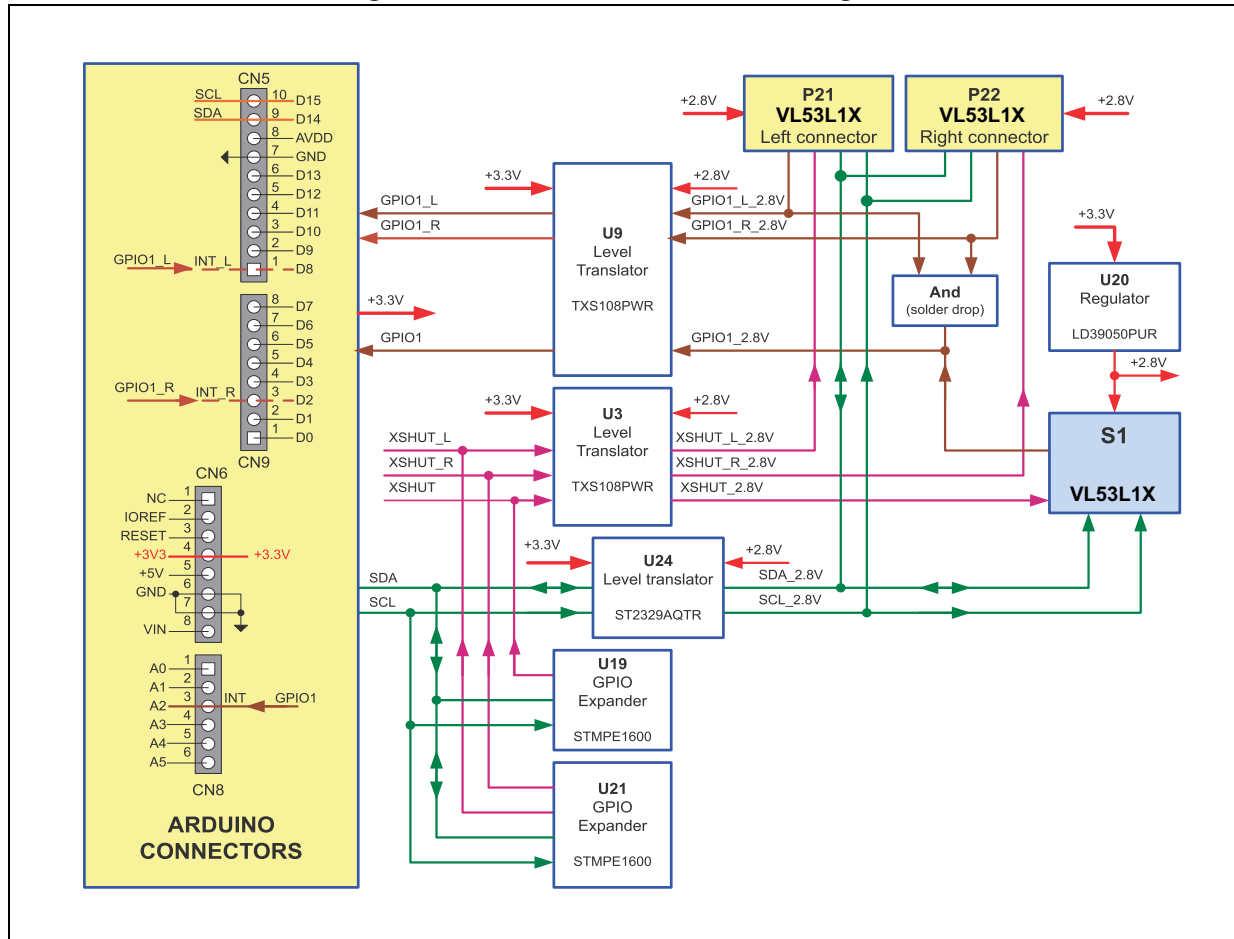

2 Optional VL53L1X breakout boards

The VL53L1X breakout boards can be directly plugged onto the VL53L1X expansion board through two 10-pin connectors or they can be connected to the board through flying leads.

When connected through flying leads, developers should break off the mini PCB from the breakout board, and use only the “VL53L1X mini PCB” which is smaller and integrates more easily into customers devices.

Figure 2. Connections of VL53L1X breakout boards

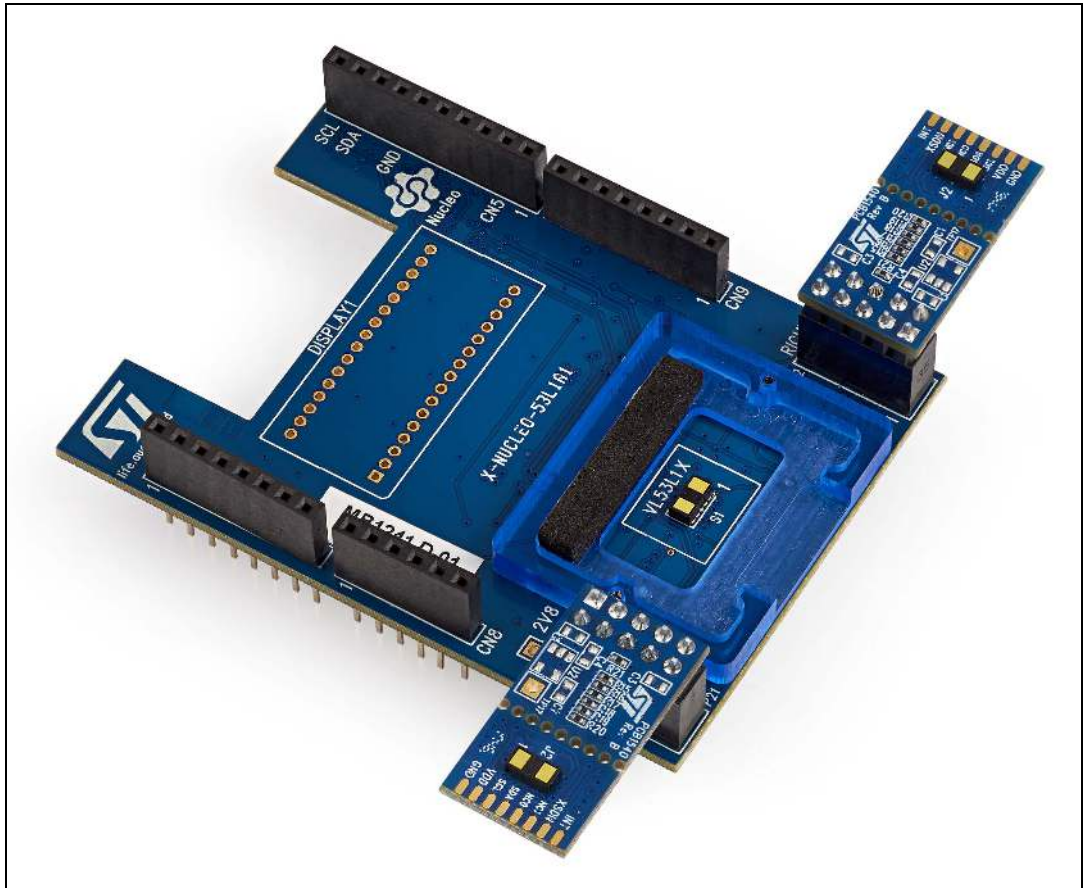

3 Laser considerations

The VL53L1X contains a laser emitter and corresponding drive circuitry. The laser output is designed to remain within Class 1 laser safety limits under all reasonably foreseeable conditions including single faults in compliance with IEC 60825-1:2014 Edition 3. The laser output remains within Class 1 limits as long as STMicroelectronics’ recommended device settings are used and the operating conditions specified in the datasheet are respected. The laser output power must not be increased by any means and no optics should be used with the intention of focusing the laser beam.

Figure 3. Class 1 laser product label



4 ECOPACK®

In order to meet environmental requirements, ST offers these devices in different grades of ECOPACK® packages, depending on their level of environmental compliance. ECOPACK® specifications, grade definitions and product status are available at: www.st.com. ECOPACK® is an ST trademark.

5 Revision history

Table 2. Document revision history

Date	Revision	Changes
02-Feb-2018	1	Initial release
20-Feb-2018	2	Updated title Replaced cover image Updated <i>Features</i> Updated <i>Description</i> Replaced “satellite boards” with “breakout boards” Updated title of <i>Figure 1: X-NUCLEO-53L1A1 circuit diagram</i> . Replaced <i>Figure 2: Connections of VL53L1X breakout boards</i> .

IMPORTANT NOTICE – PLEASE READ CAREFULLY

STMicroelectronics NV and its subsidiaries ("ST") reserve the right to make changes, corrections, enhancements, modifications, and improvements to ST products and/or to this document at any time without notice. Purchasers should obtain the latest relevant information on ST products before placing orders. ST products are sold pursuant to ST's terms and conditions of sale in place at the time of order acknowledgement.

Purchasers are solely responsible for the choice, selection, and use of ST products and ST assumes no liability for application assistance or the design of Purchasers' products.

No license, express or implied, to any intellectual property right is granted by ST herein.

Resale of ST products with provisions different from the information set forth herein shall void any warranty granted by ST for such product.

ST and the ST logo are trademarks of ST. All other product or service names are the property of their respective owners.

Information in this document supersedes and replaces information previously supplied in any prior versions of this document.

© 2018 STMicroelectronics – All rights reserved

