

Rev	AWO #	Description	Date	Apr
-		RELEASED	9/27/21	

APPROVED: _____

DATE: _____ TITLE: _____

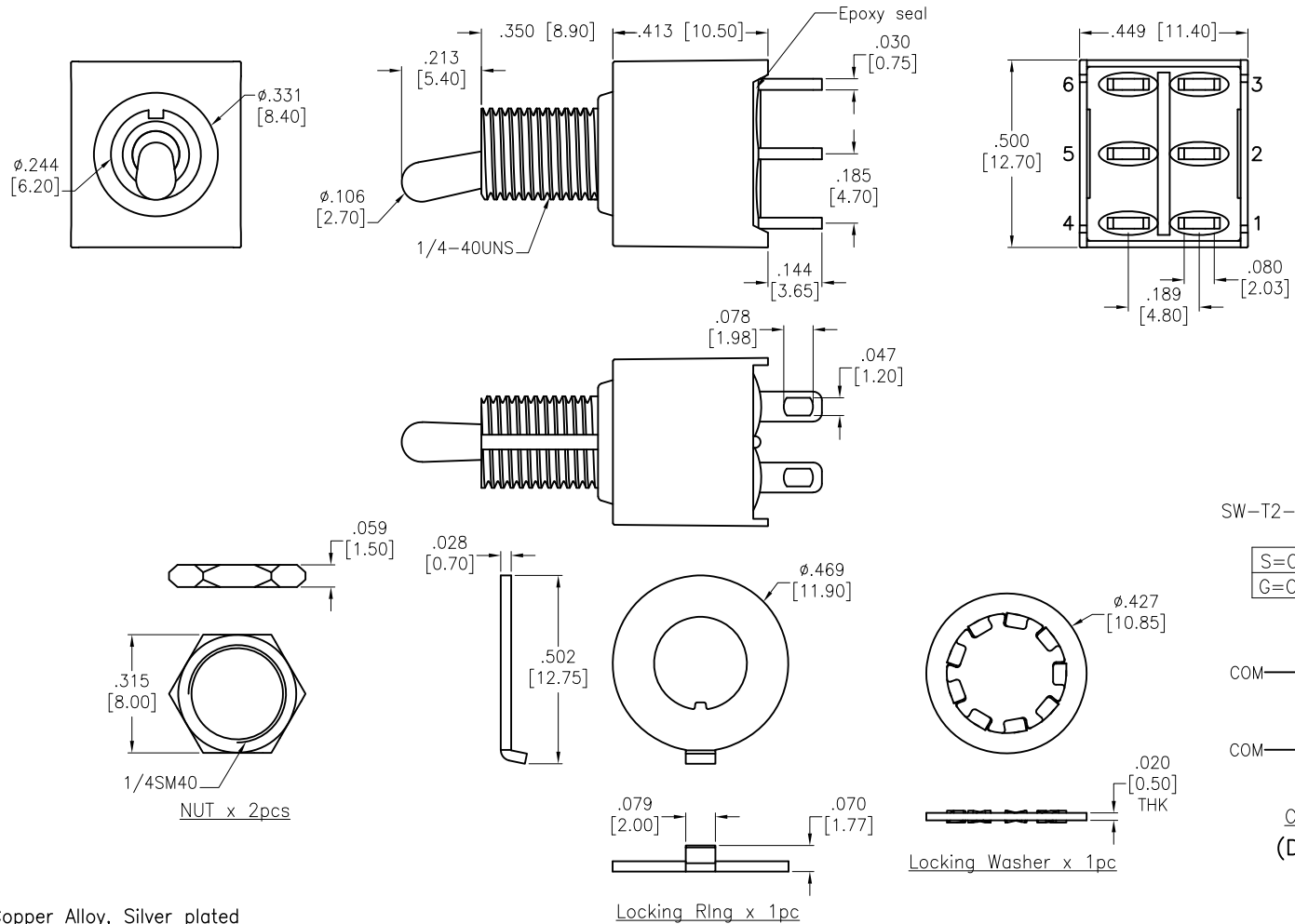

SPECIFICATIONS:

Material:
 Movable contact: Copper Alloy, Silver plated
 Terminals: Silver plated with outer layer in Gold plating
 Electrical:
 Rating: 5 Amps with resistive load @ 125VAC or 28VDC
 2 Amps with resistive load @ 250VAC
 Contact resistance: 10 mohms max initial
 Insulation resistance: 1,000 Mohms min
 Dielectric withstanding voltage: 1,500V RMS @ sea level
 Electrical life: 50,000 make and break cycles at full load
 Temperature Rating:
 Operating temperature: -30°C to +85°C
 Environmental:
 IP Class: IP67
 Lead free, RoHS compliant



UNLESS OTHERWISE SPECIFIED ALL DIMENSIONS ARE INCHES [MM]. TOLERANCES: EXCEPT AS NOTED

INCHES		HOLES	
.X	± .10	ØX	± .10
.XX	± .020	ØXX	± .015
.XXX	± .015	ØXXX	± .010

ADAM TECH

909 Rahway Avenue,
 Union, NJ 07083
 Phone: 908-687-5000
 Fax: 908-687-5710

DRAWN	JJ	9/27/21
CHECKED	RC	9/27/21
APPROVED		

TITLE
 MINIATURE TOGGLE SWITCH,
 DPDT, ON-ON, SOLDER TYPE

THIS DRAWING CONTAINS INFORMATION THAT IS PROPRIETARY AND SHOULD NOT BE USED WITHOUT PRIOR WRITTEN PERMISSION FROM ADAM TECH

SIZE	PART NO.	REV.
X	SW-T2-4B-A-T2-X-03	-
REF:	S00198T	SCALE: NTS SHEET 1 OF 1