

iDiskOnChip (iDOC) ***Flash Disk with IDE Interface***

Highlights

iDiskOnChip (iDOC) combines advanced and proven DiskOnChip technology with a standard IDE interface to complement the DiskOnChip product line.

iDiskOnChip provides:

- NAND flash-based technology
- High performance
- Platform independence
- Fast time to market - no driver required
- Reed-Solomon code-based EDC/ECC (2 Bits/Page)
- Wear-Leveling Algorithm: This algorithm guarantees the use of all flash components at the same level of the write/erase cycle
- Fast ATA host transfer rates supporting PIO-4 in true IDE mode
- IDE Master/Slave modes of operation
- 40-pin or 44-pin IDE connector
- Vertical and horizontal alignments

IDE Modes

- PIO modes 0-4 (True IDE)

Performance

- Host Data Transfer Rate:
 - Read: 5 MB/sec
 - Write: 1.5 MB/sec

Power Requirements

- Single power supply: 5V ($\pm 10\%$) or 3.3v ($\pm 5\%$)
- Current
 - Active Mode (Max.): 60 mA
 - Idle Mode (Max): 2 mA
 - Sleep mode (max): 500 μ A

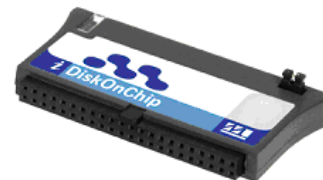

Operating Temperature

- Temperature Range: 0°C to +70°C

Environmental Conditions

- Storage Temperature: -40°C to + 80°C
- Sinusoidal Vibration: 5g, 7-2000 Hz, 3 axis
- Shock: 50 G, 3 axes

System Compatibility

- Compatible with devices that support the ATA-4 Attachment (without DMA support) for Disk Drive Standard

Capacity and Packaging

- Available in capacities of 16MB to 1536MB
- Alignments:
 - Vertical
 - Horizontal, left-oriented
 - Horizontal, right-oriented

Mechanical dimensions

- Vertical version:
 - 40-pin: 56.3 x 6.0 x 30.6 (mm) (LxWxH)
 - 44-pin: 53.0 x 6.0 x 31.2 (mm) (LxWxH)
- Horizontal version:
 - 40-pin: 55.0 x 30.4 x 9.1 (mm) (LxWxH)
 - 44-pin: 48.0 x 32.6 x 5.9 (mm) (LxWxH)

TABLE OF CONTENTS

1. Introduction	4
2. Product Overview	5
2.1 Product Description	5
2.2 Pin Assignment.....	6
2.3 Pin Description	7
3. Theory of Operation	9
3.1 Overview.....	9
3.2 Controller.....	9
3.3 Error Detection and Correction.....	9
3.4 Wear-Leveling	10
4. Installation Requirements	11
4.1 iDiskOnChip Pin Directions	11
4.2 iDiskOnChip Left/Right Orientation, Horizontal Version	11
4.3 Electrical Connections for iDiskOnChip.....	12
4.4 Installing iDiskOnChip in a Two-Drive Configuration (Master/Slave)	12
4.4.1 Vertical Configuration	12
4.4.2 Horizontal Configuration.....	13
5. Power Management.....	14
6. Specifications	15
6.1 CE and FCC Compatibility.....	15
6.2 Environmental Specifications	15
6.2.1 Temperature Ranges	15
6.2.2 Humidity.....	15
6.2.3 Shock and Vibration	15
6.2.4 Mean Time between Failures (MTBF).....	15
6.2.5 Endurance	16
6.3 Mechanical Dimensions.....	16
6.3.1 40-Pin Horizontal Version.....	16
6.3.2 44-Pin Horizontal Version.....	16
6.3.3 40-Pin Vertical Version.....	17
6.3.4 44-Pin Vertical Version.....	17

6.4	Electrical Specifications.....	18
6.4.1	Absolute Maximum Ratings.....	18
6.4.2	DC Characteristics	18
6.4.3	AC Characteristics.....	18
7.	Ordering Information.....	20
	How to Contact Us	23

1. INTRODUCTION

This data sheet includes the following sections:

- Section 1:** Overview of data sheet contents
- Section 2:** Product overview, including brief product description, pin assignment and description
- Section 3:** Theory of operation
- Section 4:** Installation requirements, including electrical cabling and master/slave configurations
- Section 5:** Power management for the various iDiskOnChip operational modes
- Section 6:** Product specifications, including mechanical and electrical
- Section 7:** Product ordering information and available product configurations

For additional information on M-Systems' flash disk products, please contact one of the offices listed on the back page.

2. PRODUCT OVERVIEW

2.1 Product Description

iDiskOnChip complements the DiskOnChip product line, offering full IDE capabilities, high performance, a built-in ECC system and flexible design options. It can be used in any system with an IDE bus and can work with any operating system, since the driver is handled at the BIOS level.

iDiskOnChip is based on NAND flash technology. This technology is superior in its data storage characteristics, featuring the industry's highest write and erase performance, as well as the highest burst read/write transfer rate. Additionally, NAND flash technology is known for its high density and small die size, with the related cost and real estate benefits. Data integrity is guaranteed through embedded error detection and error correction code (EDC/ECC) that automatically detects and corrects data errors. An on-chip ECC unit generates the required code bytes for error detection and correction of up to 2 bits per 512-byte data sector. Code-byte generation during write operations, as well as error detection during read operation, is implemented on the fly without performance degradation.

iDiskOnChip is ergonomically designed for easy installation and ready-to-run operation. Available in 40-pin and 44-pin connector packages, iDiskOnChip fits easily into any platform with an IDE connector.

The horizontal version is provided in both left and right orientations, giving maximum flexibility for insertion to the host platform.

iDiskOnChip is available in capacities ranging from 16MB to 1536MB, making the upgrade path simple and fast.

2.2 Pin Assignment

iDiskOnChip uses a standard IDE pinout. See Table 1 for iDiskOnChip pin assignments.

Table 1: iDiskOnChip Pin Assignment

Pin No.	Signal	Function	Pin No.	Signal	Function	
1	RESET#	Host Reset	2	GND	Ground	
3	HD7	Host Data Bit 7	4	HD8	Host Data Bit 8	
5	HD6	Host Data Bit 6	6	HD9	Host Data Bit 9	
7	HD5	Host Data Bit 5	8	HD10	Host Data Bit 10	
9	HD4	Host Data Bit 4	10	HD11	Host Data Bit 11	
11	HD3	Host Data Bit 3	12	HD12	Host Data Bit 12	
13	HD2	Host Data Bit 1	14	HD13	Host Data Bit 13	
15	HD1	Host Data Bit 1	16	HD14	Host Data Bit 14	
17	HD0	Host Data Bit 0	18	HD15	Host Data Bit 15	
19	GND	Ground	20	40-pin	VCC ¹	Supply Voltage
				44-pin	KEY	Cut pin
21	NC	Not Connected	22	GND	Ground	
23	HLOW#	Host I/O Write	24	GND	Ground	
25	HIOR#	Host I/O Read	26	GND	Ground	
27	IORDY	I/O Ready	28	CSEL	Master/Slave Select	
29	NC	Not Connected	30	GND	Ground	
31	INTRQ	Interrupt Request	32	IOIS16#	CS I/O 16-Bit	
33	HA1	Host Address Bit 1	34	PDIAG#	Passed Diagnostics	
35	HA0	Host Address Bit 0	36	HA2	Host Address Bit 2	
37	CS0#	Chip Select 0	38	CS1#	Chip Select 1	
39	DASP#	Drive Active/ Drive 1 Present	40	GND	Ground	
41 ²	NC	Not Connected	42 ²	VCC	Supply Voltage	
43 ²	GND	Ground	44 ²	RESERVED	Reserved	

1. In the 40-pin version, this pin is defined as VCC to reduce the need for an external power connector. In the 44-pin version, this pin is defined as KEY, according to the ATA standard.
2. The 40-pin version does not contain pins 41-44.

NC = These pins are not connected internally.

RESERVED = All reserved signals must be left floating.

2.3 Pin Description

Table 2 describes the pin descriptions for iDiskOnChip.

Table 2: iDiskOnChip Pin Description

Signal	Pin No.	Description	Signal Type
System Interface			
HD15-HD0	3-18	Host Data bus [15:0]. 16-bit bi-directional data input/output bus. HD15 is the most significant bit, while HD0 is the least significant bit. This bus carries data, commands and status information between the host and iDiskOnChip. The lower 8 bits are used for 8-bit register transfers. Data transfers are 16 bits wide.	I/O
HA2-HA0	33,35,36	Host Address bus HA[2:0]: Select the registers in the iDiskOnChip controller.	Input
Configuration			
DIOW#	23	Device I/O Write: Active low. Gates the data from the bus to iDiskOnChip. The clocking occurs on the rising edge of the signal.	Input
DIOR#	25	Device I/O Read: Active low. Gates the data to the bus from iDiskOnChip. The clocking occurs on the falling edge of the signal.	Input
CSEL	28	Configuration Select: Determines the device configuration as either Master or Slave. If CSEL is negated, then the device address is Master; if CSEL is asserted, then the device address is Slave.	Input
CS0#	37	Host Chip Select 0: Active low. Selects the Command Block registers.	Input
CS1#	38	Host Chip Select 1: Active low. Selects the Command Block registers.	Input
Control			
RESET#	1	Host reset: Active low.	Input
IORDY	27	I/O Ready: Negated by iDiskOnChip to extend the host transfer cycle (read or write) when the device is not ready to respond to a data transfer request.	Output
INTRQ	31	Interrupt Request: Interrupt request from iDiskOnChip to the host. The output of this signal is tri-stated if the host disables the interrupt. When asserted, this signal is negated by the device within 400 nsec of the negation of the DIOR# signal that reads the Status register. When asserted, this signal is negated by the device within 400 nsec of the negation of the DIOW# signal that writes the Command register.	Output
IOIS16#	32	I/O IS 16-Bit: Active low. Asserted (low) by iDiskOnChip to indicate to the host that the current cycle is a 16-bit (word) data transfer. When the signal is negated (high), an 8-bit data transfer is performed.	Output

Signal	Pin No.	Description	Signal Type
Status			
PDIAG#	34	Passed Diagnostics: Active low. Informs the Master drive that the self-diagnostic of the Slave drive has ended.	I/O
DASP#	39	Drive Active/Drive1 Present: Active low. This is a time-multiplexed signal that indicates that a device is active, or that Device 1 is present.	I/O
Power			
GND	2,19,22,24,26,30,40,43	Ground	Ground
VCC	42	Power supply	Supply
Other			
NC	41, 44	Not connected	N/A

3. THEORY OF OPERATION

3.1 Overview

Figure 1 shows iDiskOnChip operation from the system level, including the major hardware blocks.

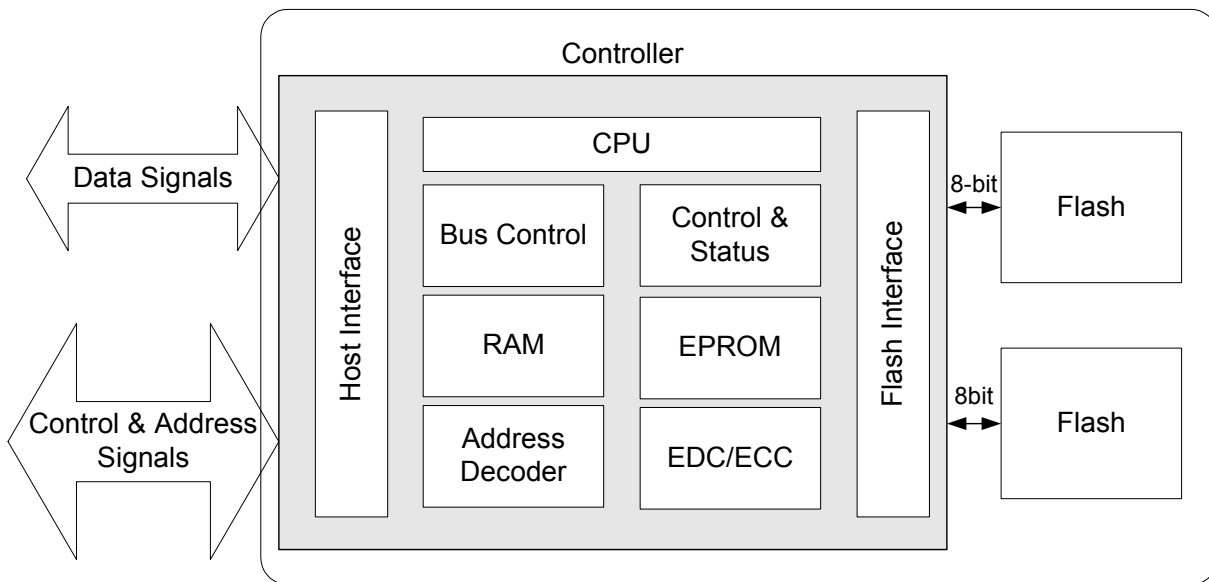

Figure 1: iDiskOnChip Block Diagram

iDiskOnChip integrates an IDE controller and flash devices. Communication with the host occurs through the host interface, using the standard ATA protocol. Communication with the flash device(s) occurs through the flash interface.

3.2 Controller

The controller is equipped with 16KB of internal memory that is used for storing code and data. The internal memory can also be used as an intermediate memory for storing data blocks during a wear-leveling procedure.

An 8KB internal boot ROM includes basic routines for accessing the flash memories and for loading the main code into the internal memory

The host interface provides all required signals, is fully compliant with the PC Card standard, and supports True-IDE mode operation requirements.

3.3 Error Detection and Correction

Highly sophisticated Error Correction Code algorithms are implemented. The ECC unit consists of the Parity Unit (parity-byte generation) and the Syndrome Unit (syndrome-byte computation). This unit implements a Reed-Solomon algorithm that can correct two bits per 512 bytes in an ECC block. Code-byte generation during write operations, as well as error detection during read operation, is implemented on the fly without any speed penalties.

3.4 Wear-Leveling

Flash memory can be erased a limited number of times. This number is called the *erase cycle limit* or *write endurance limit* and is defined by the flash array vendor. The erase cycle limit applies to each individual erase block in the flash device.

iDiskOnChip uses a wear-leveling algorithm to ensure that consecutive writes of a specific sector are not written physically to the same page in the flash. This spreads flash media usage evenly across all pages, thereby maximizing flash lifetime.

4. INSTALLATION REQUIREMENTS

4.1 iDiskOnChip Pin Directions

Figure 2 and Figure 3 illustrate the iDiskOnChip pin directions in the vertical version.

As the horizontal version uses the same connector, the same pin directions can be used for the horizontal models.

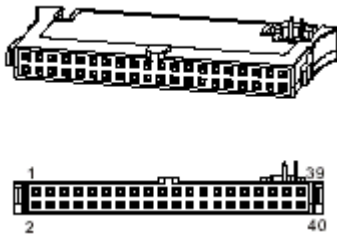

Figure 2: 40-Pin (vertical) iDiskOnChip Connector Layout

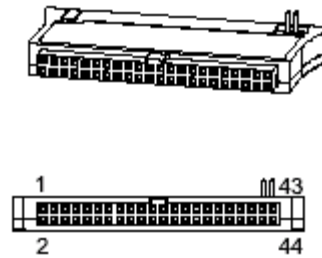

Figure 3: 44-Pin (vertical) iDiskOnChip Connector Layout

4.2 iDiskOnChip Left/Right Orientation, Horizontal Version

The right-oriented iDiskOnChip, when held as shown in Figure 4, has pin 1 on the right side. The left-oriented iDiskOnChip, when held as shown in Figure 5, has pin 1 on the left side.



Figure 4: iDiskOnChip Horizontal Version 40 pin, Right-Oriented



Figure 5: iDiskOnChip Horizontal Version 44 pin, Left-Oriented

4.3 Electrical Connections for iDiskOnChip

iDiskOnChip can be connected to the host by placing it directly on the on-board socket. If a cable is used, it should be no longer than 18 inches, and should be aligned as follows:

For 44-pin iDiskOnChip:

- Pin 1 of the cable must be aligned with pin 1 of the iDiskOnChip connector.
- Pin 44 of the cable must be aligned with pin 44 of the iDiskOnChip connector.

For 40-pin iDiskOnChip:

- Pin 1 of the cable must be aligned with pin 1 of the iDiskOnChip connector.
- Pin 40 of the cable must be aligned with pin 40 of the iDiskOnChip connector.

The 40-pin iDiskOnChip version has a separate connector for the power supply, to which a power supply cable can be connected. In addition, pin 20 can also be used for power supply connections. Please refer to the pin description for further details.

Note: For a list of recommended connectors, contact an M-Systems representative.

4.4 Installing iDiskOnChip in a Two-Drive Configuration (Master/Slave)

If iDiskOnChip is being installed as an additional IDE drive using the same IDE I/O port, jumper J1 must be set to indicate that this drive is a slave. The default is master with no jumpers. Table 3 shows the J1 jumper settings for iDiskOnChip operation in Master and Slave mode.

Table 3: Jumper Settings for Master/Slave Mode

J1 Jumper Settings	Operation Mode
No jumper is installed (open)	Master
Jumper is installed (short)	Slave

4.4.1 Vertical Configuration

The vertical configuration can operate in either Master or Slave mode. The following figures show the jumper settings for the iDiskOnChip vertical configuration.

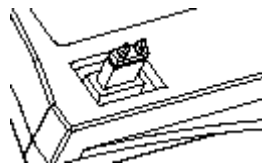

Figure 6: Slave Setting for Vertical iDiskOnChip 44-Pin Connector

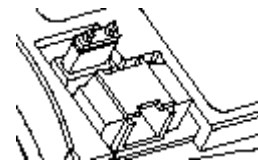

Figure 7: Slave Setting for Vertical iDiskOnChip 40-Pin Connector



Figure 8: Master Setting for Vertical iDiskOnChip 44-Pin Connector



Figure 9: Master Setting for Vertical iDiskOnChip 40-Pin Connector

4.4.2 Horizontal Configuration

The horizontal configuration can operate in either Master or Slave mode. The mode can be set via the device jumper settings. In addition, the jumpers can be set to cable select. The following figures show the jumper settings for iDiskOnChip horizontal configuration.

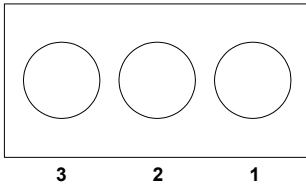

Figure 10: Jumper Not Installed, iDiskOnChip Configured as Master

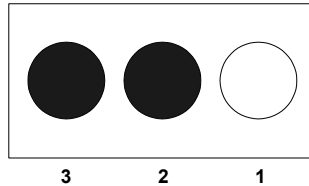

Figure 11: Jumper Installed on Pins 2-3, iDiskOnChip Configured According to Cable Select

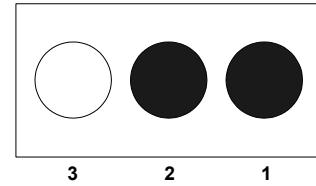

Figure 12: Jumper Installed on Pins 1-2, iDiskOnChip Configured as Slave

5. POWER MANAGEMENT

iDiskOnChip has three operational modes, listed below. Idle and Sleep modes provide automatic power management.

- **Active:** If the iDiskOnChip controller receives any Command In or Soft Reset, it enters Active mode. In Active mode, iDiskOnChip can execute any supported ATA command. The power consumption level is the highest in this mode.
- **Idle:** After the iDiskOnChip controller executes any ATA command or Soft Reset, it automatically enters Idle mode. Power consumption is reduced as compared with Active mode.
- **Sleep:** The iDiskOnChip controller automatically transfers the device from Idle into Sleep mode if there is no Command In or Soft Reset from the host for about 16 ms. This time interval can be modified by firmware if necessary. In Sleep mode, iDiskOnChip power consumption is at its lowest level. During Sleep mode, the system main clock is stopped. This mode can be released through a hardware reset, software reset, or when any ATA command is asserted.

6. SPECIFICATIONS

6.1 CE and FCC Compatibility

iDiskOnChip conforms to CE requirements and FCC standards.

6.2 Environmental Specifications

6.2.1 Temperature Ranges

Temperature Range 0°C to +70°C

Storage Temperature: -40°C to +80°C

6.2.2 Humidity

Relative Humidity: 10-95%, non-condensing

6.2.3 Shock and Vibration

Table 4: Shock/Vibration Testing for iDiskOnChip

Reliability Tests	Test Conditions	Reference Standards
Vibration	7 Hz to 2000 Hz, 5 g, 3 axis	IEC 68-2-6
Mechanical Shock	Duration: 10 ms, 50 g, 3 axes	IEC 68-2-27
Drop Unit	From a height of 1.5 m	IEC 68-2-32

6.2.4 Mean Time between Failures (MTBF)

Table 5 summarizes the MTBF prediction results for various iDOC configurations. The analysis was performed using a RAM Commander™ failure rate prediction.

- **Failure Rate:** The total number of failures within an item population, divided by the total number of life units expended by that population, during a particular measurement interval under stated condition.
- **Mean Time Between Failures (MTBF):** A basic measure of reliability for repairable items: The mean number of life units during which all parts of the item perform within their specified limits, during a particular measurement interval under stated conditions.

Table 5: iDOC MTBF

Product	Condition	MTBF (Hours)	Failure Rate per Million Hours
Vertical 40-pin	Telcordia SR-332 GB, 25°C	5,267,540	0.1898
Horizontal 40-pin		4,650,009	0.2151
Vertical 44-pin		6,188,875	0.1616
Horizontal 44-pin		6,102,525	0.1639

6.2.5 Endurance

iDiskOnChip sustains more than 100,000 write/erase cycles and an unlimited number of read cycles. Performance is enhanced by the following features:

6.3 Mechanical Dimensions

6.3.1 40-Pin Horizontal Version

Figure 13 shows the mechanical dimensions of both left- and right-oriented iDiskOnChip, 40-pin horizontal version.

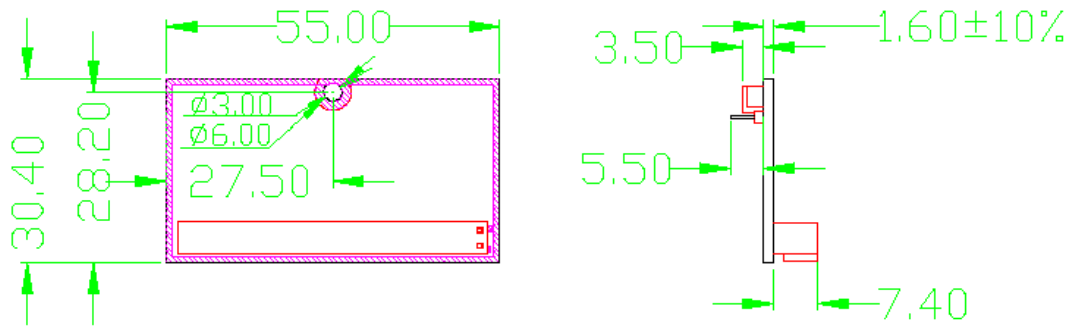

Figure 13: Mechanical Dimensions of iDiskOnChip, 40-Pin Horizontal Version

6.3.2 44-Pin Horizontal Version

Figure 14 shows the mechanical dimensions of left-oriented iDiskOnChip, 44-pin horizontal version.

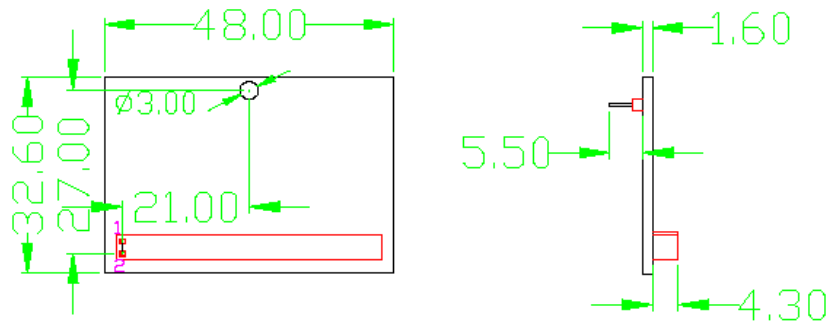

Figure 14: Mechanical Dimensions of iDiskOnChip, 44-Pin Horizontal Version

6.3.3 40-Pin Vertical Version

Figure 15 shows the mechanical dimensions of iDiskOnChip, 40-pin vertical version.

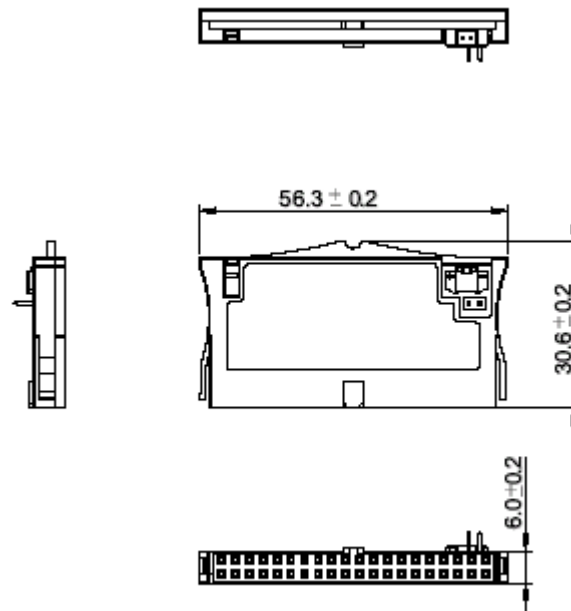

Figure 15: Dimensions of iDiskOnChip, 40-Pin Vertical Version

6.3.4 44-Pin Vertical Version

Figure 16 shows the mechanical dimensions of iDiskOnChip, 44-pin vertical version.

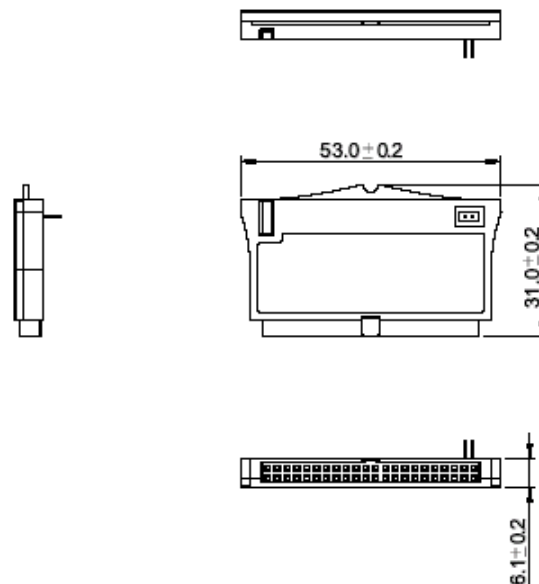

Figure 16: Dimensions of iDiskOnChip, 44-Pin Vertical Version

6.4 Electrical Specifications

6.4.1 Absolute Maximum Ratings

Table 6: iDiskOnChip Absolute Maximum Ratings

Symbol	Parameter	Min	Max	Unit
V_{IN}	Input Voltage (5v)	4.5	5.5	V
V_{IN}	Input Voltage (3.3v)	3.13	3.43	V
T_a	Operating Temperature	0	+70	°C
T_{st}	Storage Temperature	-40	+80	°C

6.4.2 DC Characteristics

Table 7: iDiskOnChip DC Characteristics

Symbol	Parameter	Min	Max	Unit
V_{IH}	Input High voltage	2.0	$V_{CC} + 0.3$	V
V_{IL}	Input Low voltage	-0.3	0.8	V
V_{OH}	Output High voltage	2.4	-	V
V_{OL}	Output Low voltage	-	0.45	V
I_{CC}	Operating current	-	60 mA (max); 20mA (typ)	mA
I_{CCS}	Standby mode current (*)	-	2 mA (max); 500 μ A (typ)	mA
I_{LI}	Input leakage current	-	± 20	μ A
I_{LO}	Output leakage current	-	± 20	μ A

$T_a=0^\circ\text{C}$ to $+70^\circ\text{C}$, $V_{CC}=5.0\text{V} \pm 10$

*Measured with flash memory and host interface

6.4.3 AC Characteristics

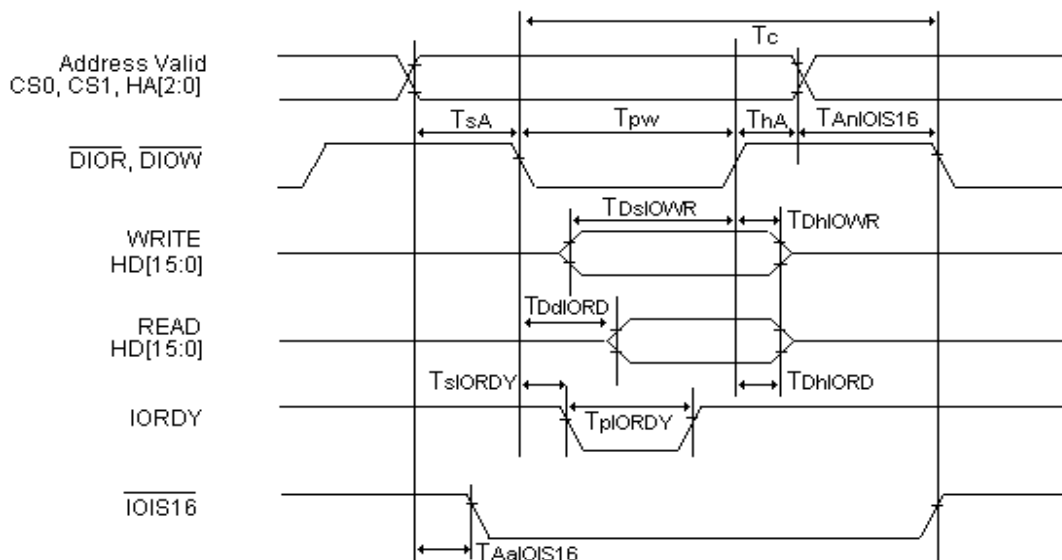

Figure 17: Timing Diagram, PIO Mode 4

Table 8: Timing Specifications, PIO Mode 4

Symbol	Parameter	Min	Max	Unit
tcR	Cycle time	120		ns
tsuA	Address setup time for IORD/IOWR	25		ns
thA	Address hold time from IORD/IOWR	10		ns
tw	IORD/IOWR pulse width	70		ns
trec	IORD/IOWR recovery time	25		ns
tsuD(IORD)	Data setup time for IORD	20		ns
thD(IORD)	Data hold following IORD	5		ns
tdis(IORD)	Output disable time from IORD		30	ns
tsuD(IOWR)	Data setup time for IOWR	20		ns
thD(IOWR)	Data hold following IOWR	10		ns

7. ORDERING INFORMATION

MD11AC-DXXX

where:

MD11 M-Systems' iDiskOnChip product

A 5: Vertical alignment
 6: Horizontal alignment, left oriented
 7: Horizontal alignment, right oriented

C 0: 40-pin IDE connector
 1: 44-pin IDE connector

DXXX Capacity (MB): 16, 32, 64, 128, 192, 256, 512, 768, 1024, 1536

Refer to Table 9 for the combinations currently available and the associated order numbers.

Table 9: Available Combinations

Capacity (MB)	IDE Connector	Alignment	Ordering Code	Availability
16	40-pin	Vertical	MD1150-D16	Available
		Horizontal (left)	MD1160-D16	Available
		Horizontal (right)	MD1170-D16	Available
	44-pin	Vertical	MD1151-D16	Available
		Horizontal (left)	MD1161-D16	Available
		Horizontal (right)	MD1171-D16	Available
32	40-pin	Vertical	MD1150-D32	Available
		Horizontal (left)	MD1160-D32	Available
		Horizontal (right)	MD1170-D32	Available
	44-pin	Vertical	MD1151-D32	Available
		Horizontal (left)	MD1161-D32	Available
		Horizontal (right)	MD1171-D32	Available
64	40-pin	Vertical	MD1150-D64	Available
		Horizontal (left)	MD1160-D64	Available
		Horizontal (right)	MD1170-D64	Available
	44-pin	Vertical	MD1151-D64	Available
		Horizontal (left)	MD1161-D64	Available
		Horizontal (right)	MD1171-D64	Available

Capacity (MB)	IDE Connector	Alignment	Ordering Code	Availability
128	40-pin	Vertical	MD1150-D128	Available
		Horizontal (left)	MD1160-D128	Available
		Horizontal (right)	MD1170-D128	Available
	44-pin	Vertical	MD1151-D128	Available
		Horizontal (left)	MD1161-D128	Available
		Horizontal (right)	MD1171-D128	Available
192	40-pin	Vertical	MD1150-D192	October 2004
		Horizontal (left)	MD1160-D192	Available
		Horizontal (right)	MD1170-D192	Available
	44-pin	Vertical	MD1151-D192	August 2004
		Horizontal (left)	MD1161-D192	Available
		Horizontal (right)	MD1171-D192	Available
256	40-pin	Vertical	MD1150-D256	Available
		Horizontal (left)	MD1160-D256	Available
		Horizontal (right)	MD1170-D256	Available
	44-pin	Vertical	MD1151-D256	Available
		Horizontal (left)	MD1161-D256	Available
		Horizontal (right)	MD1171-D256	Available
512	40-pin	Vertical	MD1150-D512	Available
		Horizontal (left)	MD1160-D512	Available
		Horizontal (right)	MD1170-D512	Available
	44-pin	Vertical	MD1151-D512	Available
		Horizontal (left)	MD1161-D512	Available
		Horizontal (right)	MD1171-D512	Available
768	40-pin	Vertical	MD1150-D512	October 2004
		Horizontal (left)	MD1160-D512	Available
		Horizontal (right)	MD1170-D512	Available
	44-pin	Vertical	MD1151-D512	August 2004
		Horizontal (left)	MD1161-D512	Available
		Horizontal (right)	MD1171-D512	Available
1024	40-pin	Vertical	MD1150-D512	October 2004
		Horizontal (left)	MD1160-D512	Available
		Horizontal (right)	MD1170-D512	Available
	44-pin	Vertical	MD1151-D512	August 2004
		Horizontal (left)	MD1161-D512	Available
		Horizontal (right)	MD1171-D512	Available

Capacity (MB)	IDE Connector	Alignment	Ordering Code	Availability
1536	40-pin	Vertical	MD1150-D512	October 2004
		Horizontal (left)	MD1160-D512	Available
		Horizontal (right)	MD1170-D512	Available
	44-pin	Vertical	MD1151-D512	August 2004
		Horizontal (left)	MD1161-D512	Available
		Horizontal (right)	MD1171-D512	Available

Note: iDiskOnChip 40-pin requires an additional cable for the power supply. The ordering information is: DOC-IDE40-CABLE.

HOW TO CONTACT US

USA

M-Systems Inc.
8371 Central Ave, Suite A
Newark CA 94560
Phone: +1-510-494-2090
Fax: +1-510-494-5545

Japan

M-Systems Japan Inc.
Asahi Seimei Gotanda Bldg., 3F
5-25-16 Higashi-Gotanda
Shinagawa-ku Tokyo, 141-0022
Phone: +81-3-5423-8101
Fax: +81-3-5423-8102

Taiwan

M-Systems Asia Ltd.
14 F, No. 6, Sec. 3
Minqun East Road
Taipei, Taiwan, 104
Tel: +886-2-2515-2522
Fax: +886-2-2515-2295

China

M-Systems China Ltd.
Room 121-122
Bldg. 2, International Commerce & Exhibition Ctr.
Hong Hua Rd.
Futian Free Trade Zone
Shenzhen, China
Phone: +86-755-8348-5218
Fax: +86-755-8348-5418

Europe

M-Systems Ltd.
7 Atir Yeda St.
Kfar Saba 44425, Israel
Tel: +972-9-764-5000
Fax: +972-3-548-8666

Internet

www.m-systems.com

General Information

info@m-sys.com

Sales and Technical Information

techsupport@m-sys.com

This document is for information use only and is subject to change without prior notice. M-Systems Flash Disk Pioneers Ltd. assumes no responsibility for any errors that may appear in this document. No part of this document may be reproduced, transmitted, transcribed, stored in a retrievable manner or translated into any language or computer language, in any form or by any means, electronic, mechanical, magnetic, optical, chemical, manual or otherwise, without prior written consent of M-Systems.

M-Systems products are not warranted to operate without failure. Accordingly, in any use of the Product in life support systems or other applications where failure could cause injury or loss of life, the Product should only be incorporated in systems designed with appropriate and sufficient redundancy or backup features.

Contact your local M-Systems sales office or distributor, or visit our website at www.m-systems.com to obtain the latest specifications before placing your order.

© 2004 M-Systems Flash Disk Pioneers Ltd. All rights reserved.

M-Systems, DiskOnChip, DiskOnChip Millennium, DiskOnKey, DiskOnKey MyKey, FFD, Fly-By, iDiskOnChip, iDOC, mDiskOnChip, mDOC, Mobile DiskOnChip, Smart DiskOnKey, SmartCaps, SuperMAP, TrueFFS, uDiskOnChip, uDOC, and Xkey are trademarks or registered trademarks of M-Systems Flash Disk Pioneers, Ltd. Other product names or service marks mentioned herein may be trademarks or registered trademarks of their respective owners and are hereby acknowledged. All specifications are subject to change without prior notice.