

TS72461K - 10W CW GaN Broadband RF Switch SP4T

1.0 Features

- Low insertion loss: 0.40dB @ 800MHz
- High linear power handling
- No external DC blocking capacitors on RF lines
- 40dBm CW hot switching capable
- Versatile 2.6-5.5V power supply
- Operating frequency: 400MHz to 3.8GHz



Figure 1 Device Image
(16 Pin 3x3x0.8mm QFN Package)

2.0 Applications

- Cellular infrastructure
- Small cells
- LTE relays and microcells
- Satellite terminals



RoHS/REACH/Halogen Free Compliance

3.0 Description

The TS72461K is a symmetrical reflective Single Pole Four Throws (SP4T) switch based on the cutting edge GaN technology designed for broadband and high power switching applications. Its broadband behavior from 400MHz to 3.8GHz frequencies makes the TS72461K an excellent switch for all applications requiring low insertion loss, high isolation and high linearity within a small package size. The 4 control lines can be selected up to 16 possible positions independently.

The TS72461K is packaged into a compact Quad Flat No lead (QFN) 3x3mm 16 leads plastic package.

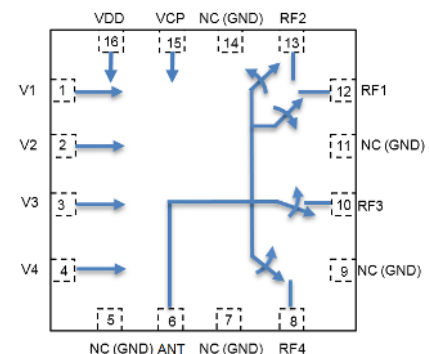

Figure 2 Function block diagram
(Top View)

4.0 Ordering Information

Table 1 Ordering Information

Base Part Number	Package Type	Form	Qty	Reel Diameter	Reel Width	Orderable Part Number
TS72461K	16 Pin 3x3x0.8mm QFN	Tape and Reel	3000	13" (330mm)	18mm	TS72461KMTRPBF
Evaluation Board						TS72461K-EVB

5.0 Pin Description

Table 2 Pin Definition

Pin Number	Pin Name	Description
1	V1	Switch control input 1
2	V2	Switch control input 2
3	V3	Switch control input 3
4	V4	Switch control input 4
5	NC	No internal connection. Can be grounded
6	ANT	Antenna port
7	NC	No internal connection. Can be grounded
8	RF4	RF port 4
9	NC	No internal connection. Can be grounded
10	RF3	RF port 3
11	NC	No internal connection. Can be grounded
12	RF1	RF port 1
13	RF2	RF port 2
14	NC	No internal connection. Can be grounded
15	VCP	Internal charge pump voltage output. Connect a 1nF capacitor to GND on this pin to improve switching time.
16	VDD	DC Supply voltage

Note: The backside ground (thermal) pad of the package must be grounded directly to the ground plane of PCB with multiple vias to ensure proper operation and thermal management.

6.0 Absolute Maximum Ratings

Table 3 Absolute Maximum Ratings @ $T_A=+25^{\circ}\text{C}$ Unless Otherwise Specified

Parameter	Symbol	Value	Unit
Electrical Ratings			
Power Supply Voltage	VDD	2.6 to 5.5	V
Storage Temperature Range	T_{st}	-55 to +125	$^{\circ}\text{C}$
Operating Temperature Range	T_{op}	-40 to +85	$^{\circ}\text{C}$
Maximum Junction Temperature	T_J	+150	$^{\circ}\text{C}$
RF Input Power CW, 85 $^{\circ}\text{C}$	RFx	41	dBm
Peak RF Power, 1% Duty Cycle, 85 $^{\circ}\text{C}$	RFx	49	dBm
Thermal Ratings			
Thermal Resistance (junction-to-case) – bottom side	$R_{\theta JC}$	≤ 20	$^{\circ}\text{C}/\text{W}$
Thermal Resistance (junction-to-top)	$R_{\theta JT}$	≤ 37	$^{\circ}\text{C}/\text{W}$
Soldering Temperature	T_{SOLD}	≤ 260	$^{\circ}\text{C}$
ESD Ratings			
Human Body Model (HBM)	Level 1B	500 to <1000	V
Charged Device Model (CDM)	Level C3	≥ 1000	V
Moisture Rating			
Moisture Sensitivity Level	MSL	1	-

Attention:

Maximum ratings are absolute ratings. Exposure to absolute maximum rating conditions for extended periods may affect device reliability. Exceeding one or a combination of the absolute maximum ratings may cause permanent and irreversible damage to the device and/or to surrounding circuit.

7.0 Electrical Specifications

Table 4 Electrical Specifications @T_A=+25°C Unless Otherwise Specified; VDD=+2.7V; 50Ω Source/Load.

Parameter	Condition	Minimum	Typical	Maximum	Unit
Operating frequency		400		3800	MHz
Insertion loss	800MHz (No Match)		0.40		dB
	1.95GHz (No Match)		0.50		
	2.6GHz (No Match)		0.6	0.8	
	3.8GHz (With Match)		0.90		
Isolation ANT-RFx	800MHz (No Match)		45		dB
	1.95GHz (No Match)		33		
	2.6GHz (No Match)	22	28		
	3.8GHz (With Match)		23		
Return Loss ANT-RFx	800MHz (No Match)		28		dB
	1.95GHz (No Match)		25		
	2.6GHz (No Match)		18		
	3.8GHz (With Match)		15		
H2	800MHz, Pin=35dBm		-42		dBm
H3	800MHz, Pin=35dBm		-45		dBm
IIP3	800MHz		70		dBm
P0.1dB CW ^[1]	800 - 3800MHz, -40°C ~ +85°C	40			dBm
Peak P0.1dB ^[1]	1% duty cycle, 800-3800MHz, -40°C ~ +85°C		48		dBm
Switching time	50% ctrl to 10/90% of the RF value is settled. C1=1nF (refer to Figure 3)		1.2		μs
Control voltage	Power Supply V _{DD}	2.6	3.3	5.5	V
	All control pins high, V _{ih}	1.1	3.3	5.25	V
	All control pins low, V _{il}	-0.3		0.5	V
Control current	All control pins low, I _{il}		0		μA
	All control pins high, I _{ih}			7.5	μA
Current consumption, I _{DD}	Active mode		160	200	μA

Note:

[1] See Fig 3 for match

[2] P0.1dB is a figure of merit.

[3] No external DC blocking capacitors required on RF pins unless DC voltage is applied on a RF pin.

8.0 Switch Truth Table

Table 5 Switch Truth Table

V1	V2	V3	V4	Active RF Path
0	0	0	0	All OFF State
0	0	0	1	RF4
0	0	1	0	RF3
0	0	1	1	RF3, RF4
0	1	0	0	RF2
0	1	0	1	RF2, RF4
0	1	1	0	RF2, RF3
0	1	1	1	RF2, RF3, RF4
1	0	0	0	RF1
1	0	0	1	RF1, RF4
1	0	1	0	RF1, RF3
1	0	1	1	RF1, RF3, RF4
1	1	0	0	RF1, RF2
1	1	0	1	RF1, RF2, RF4
1	1	1	0	RF1, RF2, RF3
1	1	1	1	All ON. RF1, RF2, RF3, RF4

Attention: VDD should be applied first before V1 to V4, otherwise may cause damage to the device.

9.0 Evaluation Board

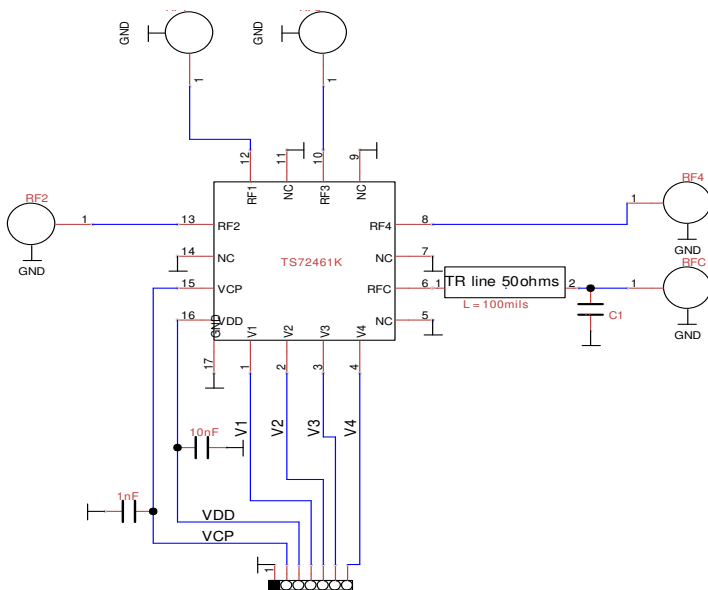

Figure 3 Evaluation Board (Tuned for 3.3-3.8GHz)

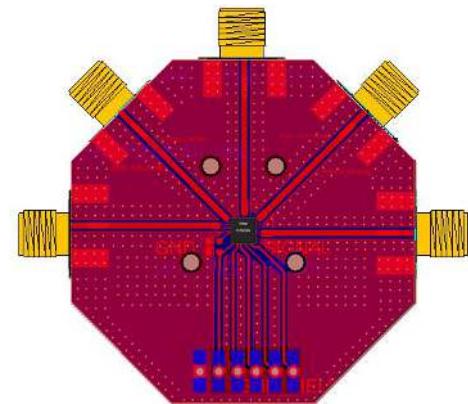

Figure 4 Evaluation Board Image

Attention:

[1] 17 refers to the center pad of the device.

[2] The purpose of connection between VCP and connector N1 is to monitor VCP, do not apply external voltage to VCP.

Table 6 Recommended Evaluation Board Component Values

Part #	Frequency Band: 3.3GHz~3.8GHz	
	Value	Manufacturer, Part#, Series
Transmission Line	50 ohms	Length 100 mils
C1	0.5pF	Passive Plus, 0603N Series

10.0 Typical Characteristics (No Match)

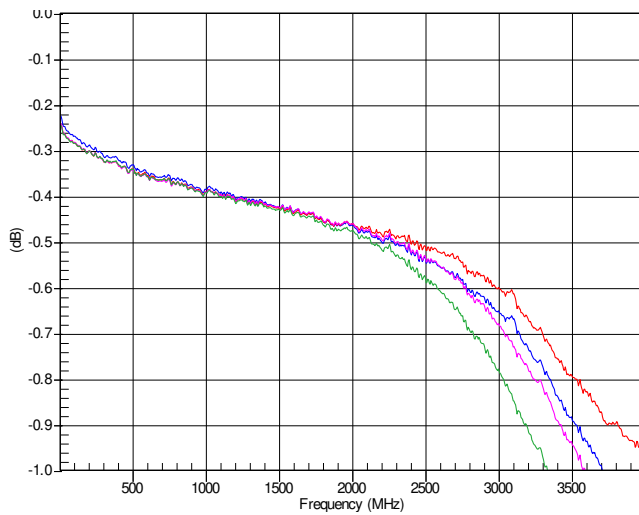

Figure 5 RF1 to RF4 Insertion Loss

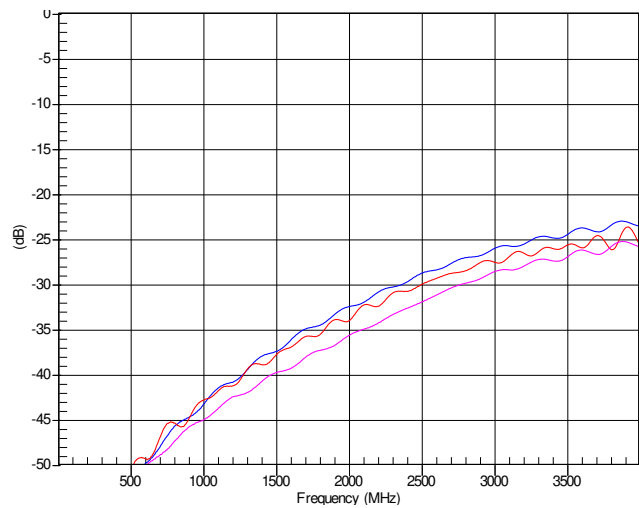

Figure 6 RF1 ON, RF1 Isolation to RF2 to RF4

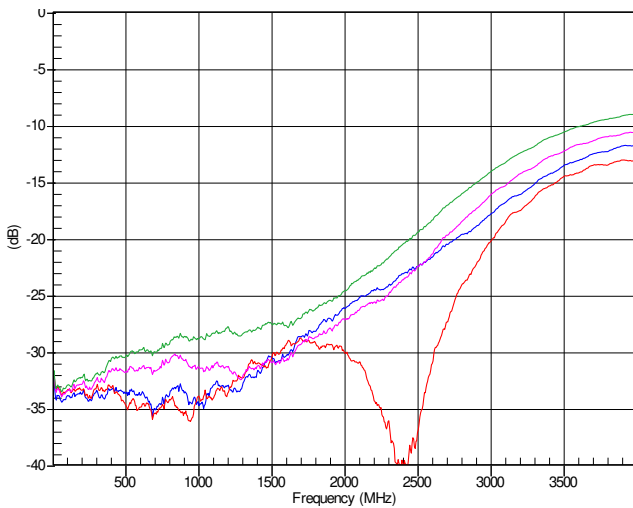

Figure 7 RF1 to RF4 Return Loss

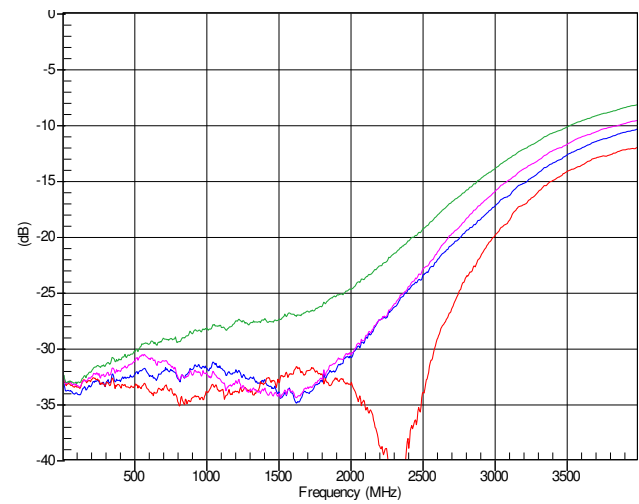

Figure 8 ANT Return Loss

11.0 Typical Characteristics (With Match – Tuned for 3.3-3.8GHz)

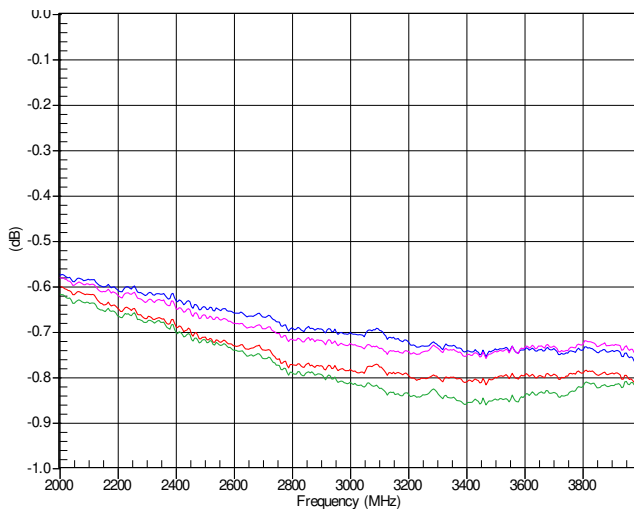

Figure 5 RF1 to RF4 Insertion Loss

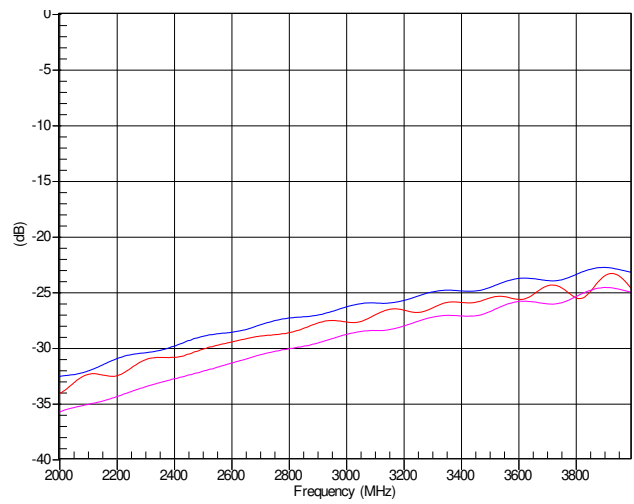

Figure 6 RF1 ON, RF1 Isolation to RF2 to RF4

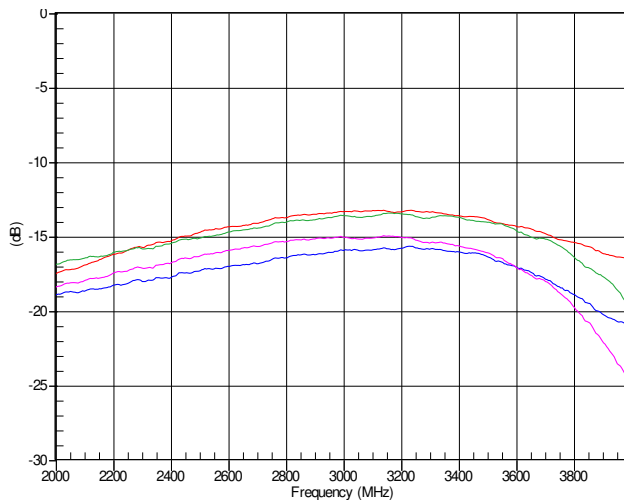

Figure 7 RF1 to RF4 Return Loss

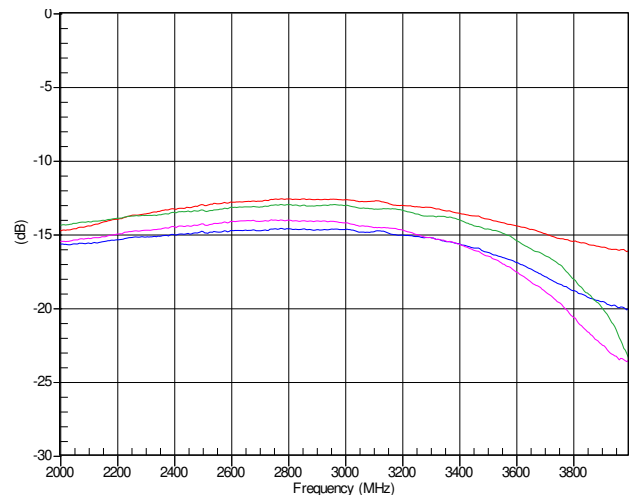

Figure 8 ANT Return Loss

12.0 Device Package Information

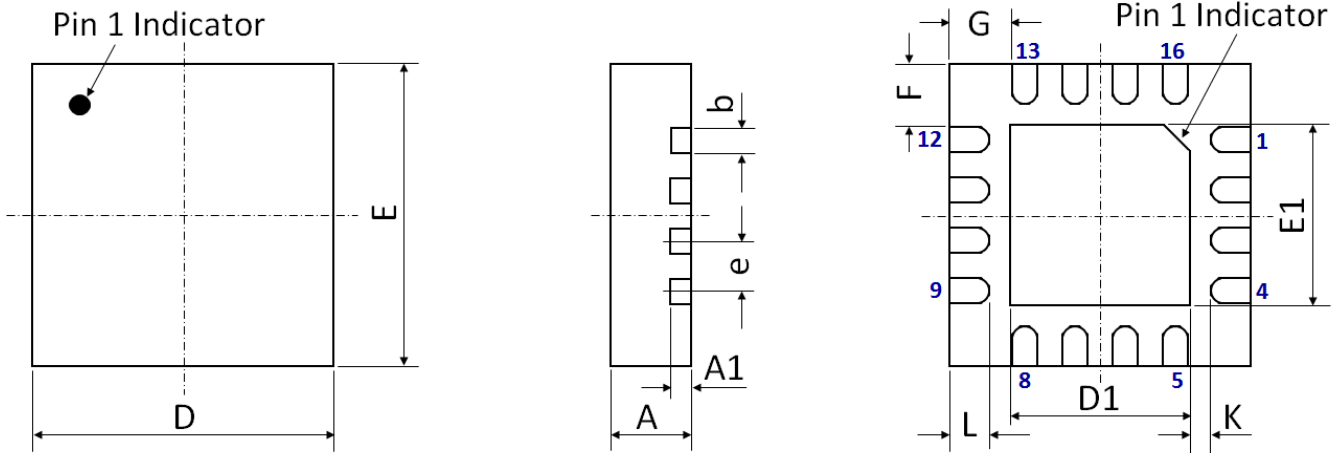

Figure 9 Device Package Drawing
(All dimensions are in mm)

Table 7 Device Package Dimensions

Dimension (mm)	Value (mm)	Tolerance (mm)	Dimension (mm)	Value (mm)	Tolerance (mm)
A	0.80	±0.05	E	3.00 BSC	±0.05
A1	0.203	±0.02	E1	1.70	±0.05
b	0.25	+0.05/-0.07	F	0.625	±0.05
D	3.00 BSC	±0.05	G	0.625	±0.05
D1	1.70	±0.05	L	0.25	±0.05
e	0.50 BSC	±0.05	K	0.40	±0.05

Note: Lead finish: Pure Sn without underlayer; Thickness: 7.5µm ~ 20µm (Typical 10µm ~ 12µm)

Attention:

Please refer to application notes [TN-001](#) and [TN-002](#) at <http://www.tagoretech.com> for PCB and soldering related guidelines.

13.0 PCB Land Design

Guidelines:

- [1] 4 layer PCB is recommended.
- [2] Via diameter is recommended to be 0.2mm to prevent solder wicking inside the vias.
- [3] Thermal vias shall only be placed on the center pad.
- [4] The maximum via number for the center pad is $3(X) \times 3(Y) = 9$.

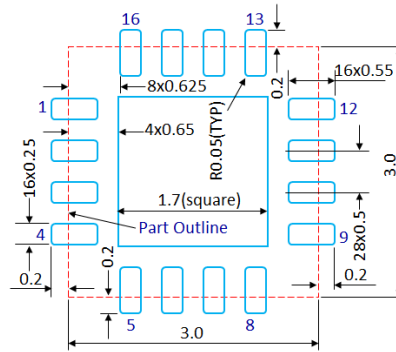

Figure 10 PCB Land Pattern
(Dimensions are in mm)

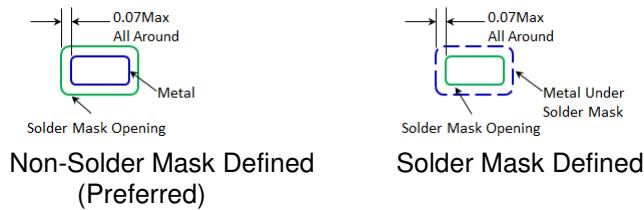

Figure 11 Solder Mask Pattern
(Dimensions are in mm)

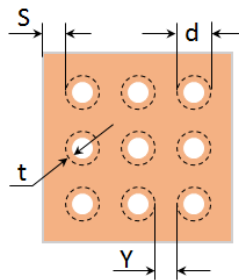

Figure 12 Thermal Via Pattern
(Recommended Values: $S \geq 0.15\text{mm}$; $Y \geq 0.20\text{mm}$; $d = 0.2\text{mm}$; Plating Thickness $t = 25\mu\text{m}$ or $50\mu\text{m}$)

14.0 PCB Stencil Design

Guidelines:

[1] Laser-cut, stainless steel stencil is recommended with electro-polished trapezoidal walls to improve the paste release.

[2] Stencil thickness is recommended to be 125 μ m.

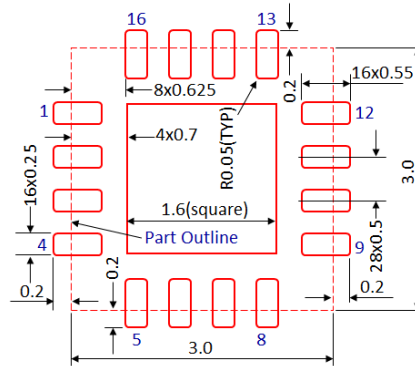

Figure 13 Stencil Openings
(Dimensions are in mm)

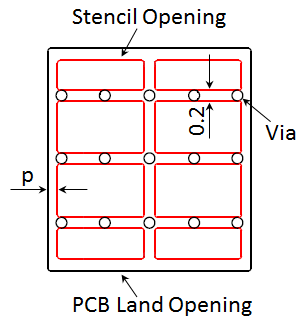

Figure 14 Stencil Openings Shall not Cover Via Areas If Possible
(Dimensions are in mm)

15.0 Tape and Reel Information

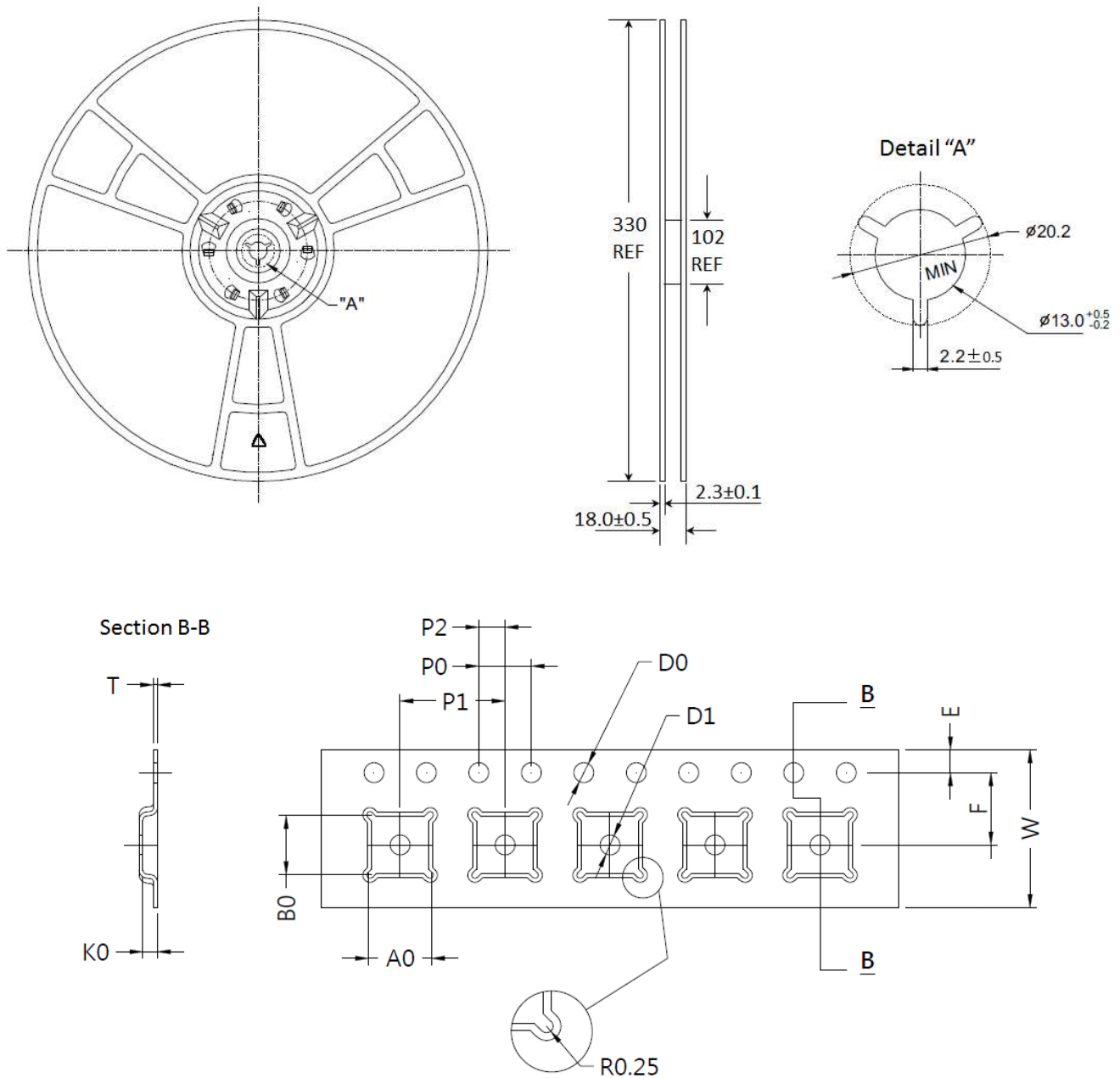

Figure 15 Tape and Reel Drawing

Table 8 Tape and Reel Dimension

Dimension (mm)	Value (mm)	Tolerance (mm)	Dimension (mm)	Value (mm)	Tolerance (mm)
A0	3.35	±0.10	K0	1.10	±0.10
B0	3.35	±0.10	P0	4.00	±0.10
D0	1.50	+0.10/-0.00	P1	8.00	±0.10
D1	1.50	+0.10/-0.00	P2	2.00	±0.05
E	1.75	±0.10	T	0.30	±0.05
F	5.50	±0.05	W	12.00	±0.30

Edition Revision 1.5 - 2019-12-11

Published by

Tagore Technology Inc.
5 East College Drive, Suite 200
Arlington Heights, IL 60004, USA

©2018 All Rights Reserved

Legal Disclaimer

The information provided in this document shall in no event be regarded as a guarantee of conditions or characteristics. Tagore Technology assumes no responsibility for the consequences of the use of this information, nor for any infringement of patents or of other rights of third parties which may result from the use of this information. No license is granted by implication or otherwise under any patent or patent rights of Tagore Technology. The specifications mentioned in this document are subject to change without notice.

Information

For further information on technology, delivery terms and conditions and prices, please contact Tagore Technology: support@tagoretech.com.