

## THREE PHASE ANGLE CONTROLLER

- ▶ Adapted to three phase star (without neutral) or delta connected loads (other wiring configurations on demand)
- ▶ Very low initial value regarding competition
- ▶ Small housing.
- ▶ Large mains frequency and voltage range.
- ▶ Fully opto-isolated full cycle three phase, phase angle controller (balanced currents, less harmonics, ...)
- ▶ Lot of possible options on demand (ramps, additional settings...).

# SGTA4650

Proportional Analog Voltage Control Input

**0-10VDC**

**300->510VAC**

**50A AC-51**

Mains Voltage	Mains Frequency	Max AC-51 Current	Control Input	In / Out / Case Insulation	Type of connections	Dimensions (WxHxD)	Weight
300 to 510VAC	40 to 65Hz	50A (with heatsink)	0-10VDC	4kV	Round tabs	100x73.5x39.5 (mm)	350g

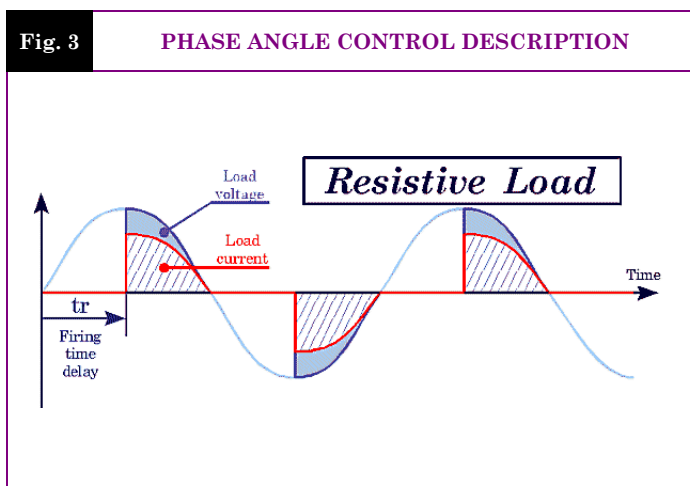
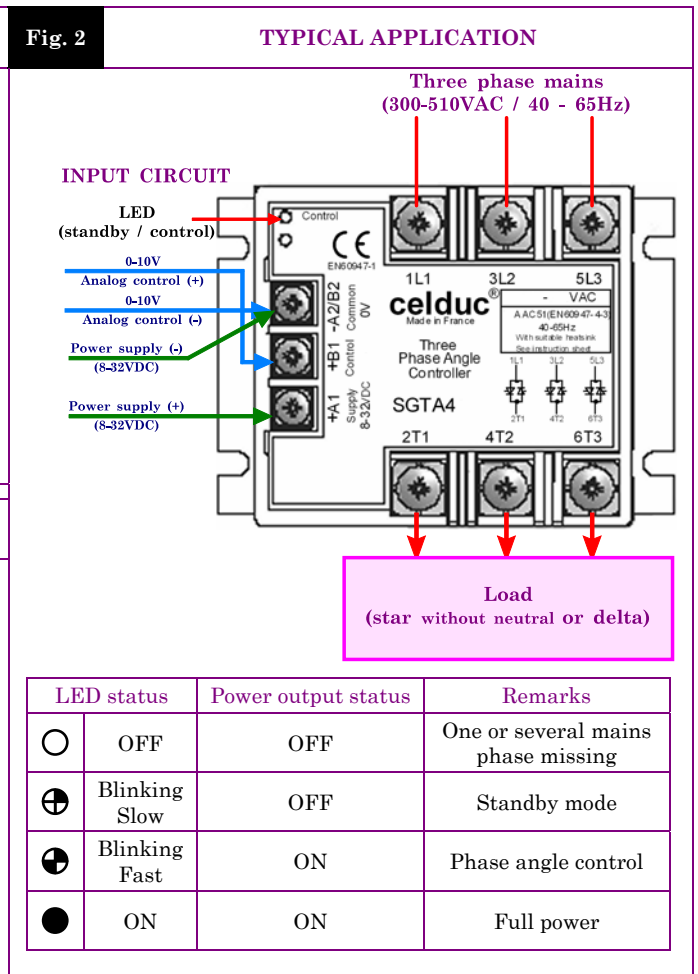
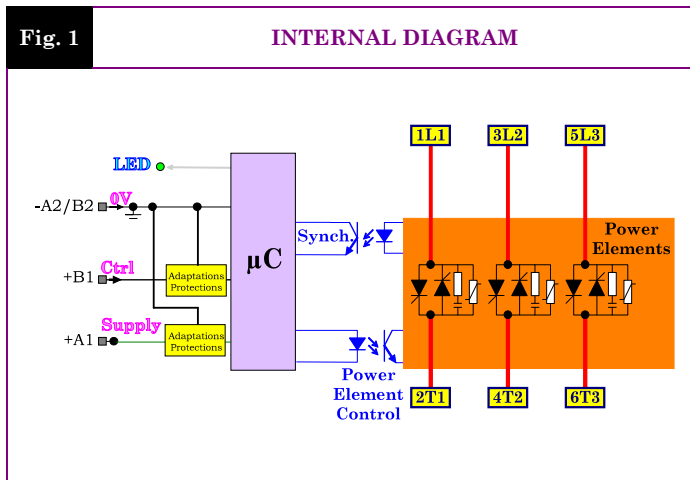

**INPUT CHARACTERISTICS**

ANALOG CONTROL INPUT	CHARACTERISTIC	LABEL	VALUE	INFO.
	Label		<b>Control</b>	
	Terminals		+B1 & -A2/B2	
	Control voltage range	<b>Uc</b>	0-10VDC	
	Release and control threshold	<b>Ucsmin</b>	0.3VDC	
	Full power control threshold	<b>Ucsmax</b>	9.7VDC	
	Max. voltage (direct & reverse)	<b>Ucmax</b>	32VDC	
	Input impedance	<b>Re</b>	100kΩ	
SUPPLY INPUT	Label		<b>Supply</b>	
	Terminals		+A1 & -A2/B2	
	Operating voltage range	<b>Us</b>	Filtered 8-32VDC	
	Max. consumption	<b>Is</b>	15mA	See fig. 6

**OUTPUT CHARACTERISTICS**

POWER CIRCUIT	CHARACTERISTIC	LABEL	VALUE	INFO.
	Mains voltage range	<b>Ue</b>	<b>300 -&gt; 510VAC</b>	
	Non-repetitive peak voltage	<b>Uep</b>	1200V	
	Overvoltage protection	<b>VDR</b>	Built-in 510V size 14 varistors	
	Maximum nominal current	<b>Ithmax (AC51)</b>	50A	With heatsink (See fig. 8)
	Non-repetitive peak overload current (1 cycle of 10ms)	<b>ITSM</b>	550A	See fig. 8
	Melting limit for choosing the protective fuses	<b>I²t</b>	1500A²s	@10ms
	Minimum load current	<b>Iemin</b>	100mA	
	Maximum leakage current	<b>Ielk</b>	7mA	@400VAC 50Hz
	Load power factor	<b>Pf</b>	0.8->1	
	Mains frequency range	<b>F</b>	40->65Hz	
	Max. off-state voltage rise	<b>dv/dt</b>	500V/μs	
	Protection against fast voltage transients		Built-in RC network	
	Max. current rise	<b>di/dt</b>	50A/μs	
	On-state voltage drop	<b>Ud</b>	$0.9 \times V_{to} \times I_{th} + r_t \times I_{th}^2$	
	On-state resistance	<b>rt</b>	12mΩ	@125°C
	On-state voltage	<b>Vto</b>	0.9V	@125°C
	Maximum junction temperature	<b>Tjmax</b>	125°C	
	Junction/case thermal resistance per power element	<b>Rthjc</b>	0.45K/W	Total = 3 power elements
	Built-in heatsink thermal resistance vertically mounted	<b>Rthra</b>	4K/W	@ΔTra=60°C
	Heatsink thermal time constant	<b>Tthra</b>	15min	@ΔTra=60°C
	Inputs/case/power outputs insulation voltages	<b>Uimp</b>	4kV	
	Isolation resistance	<b>Rio</b>	1GΩ	
	Isolation capacitance	<b>Cio</b>	<8pF	
	Storage ambient temperature	<b>Tstg</b>	-40->+100°C	
	Operating ambient temperature	<b>Tamb</b>	-40->+90°C	See fig. 7
Max. case temperature	<b>Tc</b>	100°C		

**GENERAL INFORMATION**

<b>CONNECTIONS</b>	Connections		<b>Power</b>	<b>Input</b>	
	Type		Round tabs		
	Screwdriver (advised)		Philips™ Nr2	Philips™ Nr1	
	Tightening torque (advised)		1.8Nm	0.8Nm	
<b>MISC.</b>	Housing		UL94V0		
	Mounting		Panel – 4 x M4, 1.5Nm		
	Noise level		No Noise		
	Weight		350g		

**STANDARDS**

<b>GENERAL</b>	Standards		EN60947-4-3	
	Protection level		IP00	
	Protection against direct touch		No	
	CE marking		Yes	
	UL, cUL and VDE approvals		Pending	

	TYPE OF TEST	STANDARD	LEVEL	EFFECT
<b>E.M.C. IMMUNITY</b>	E.S.D. (Electrostatic discharges)	EN61000-4-2	8kV (air) 4kV (touch)	No effect
	Radiated electromagnetic fields	EN61000-4-3	10V/m	No effect
	Fast transients bursts	EN61000-4-4	2kV direct coupling on the power side 2kV coupling by clamp on the input side	No effect
	Electric chocks	EN61000-4-5	1kV direct coupling differential mode (input and output) 2kV direct coupling common mode (input and output)	No effect
	Voltage drop	EN61000-4-11	-	

<b>E.M.C. EMISSION</b>	Radiated and conducted disturbances	NFEN55011	<p>The conducted or radiated disturbances generated by solid-state relays depend on the wiring and load configuration.</p> <p>The test method recommended by the European standards and concerning electromagnetic compatibility leading to results far from reality, we decided to advise our customer in order to adapt their filtering scheme to their application.</p> <p><b>Please contact us if you are concerned about E.M.C.</b></p>
------------------------	-------------------------------------	-----------	--

**TRANSFERT CHARACTERISTIC**

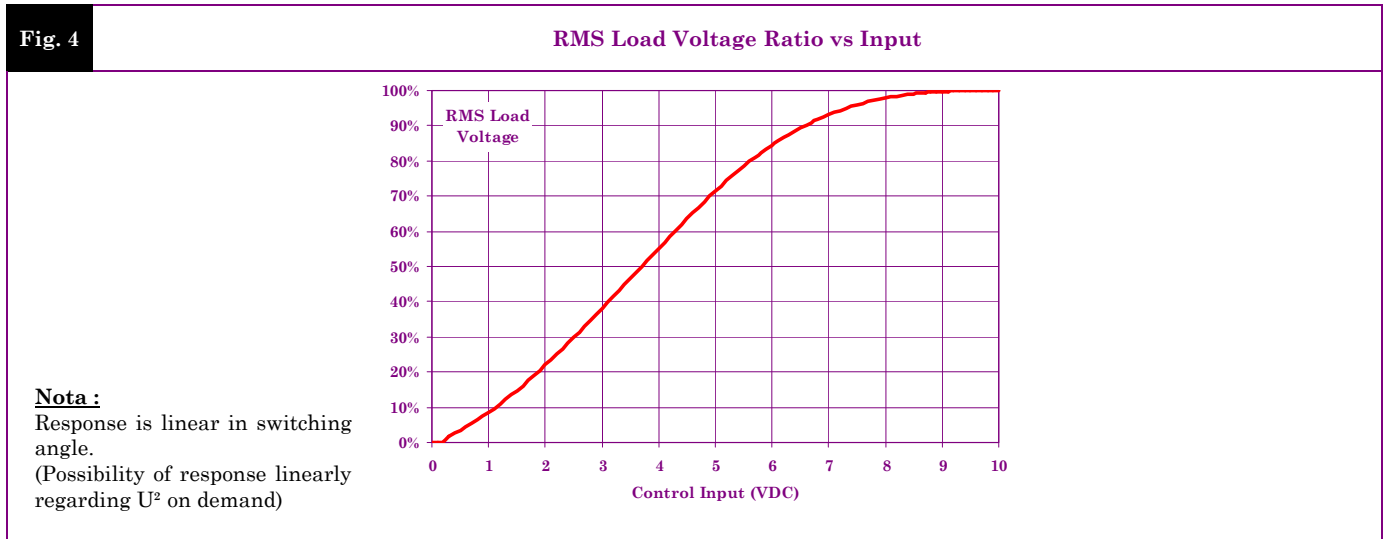

**CHARACTERISTIC CURVES**

**Fig. 5 INPUT CHARACTERISTIC**

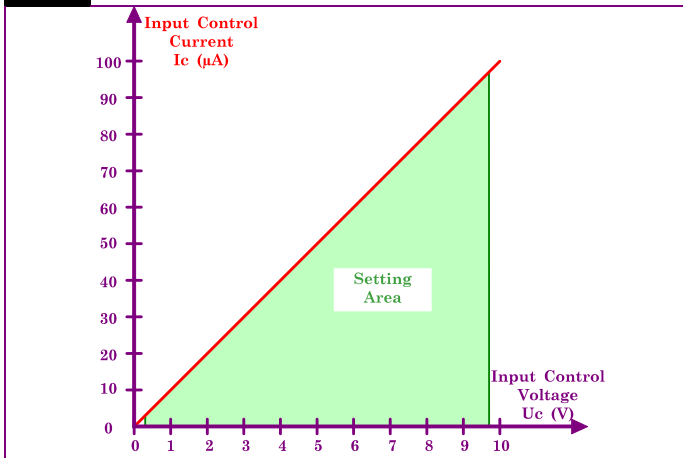

**Fig. 6 POWER SUPPLY CHARACTERISTIC**

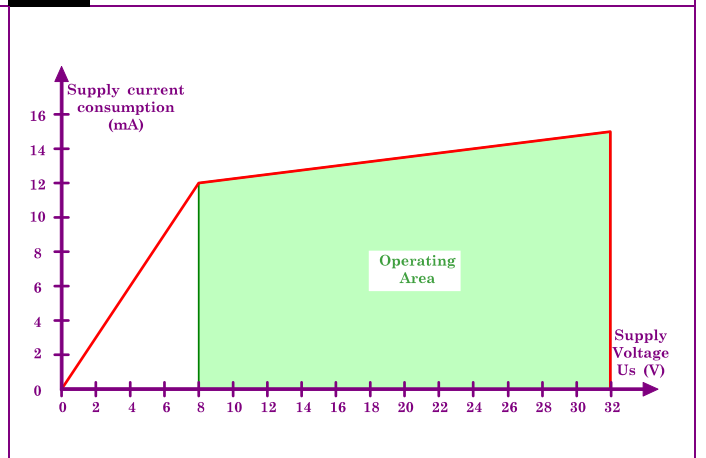

**Fig. 7 POWER DISSIPATION AND LOAD CURRENT VS AMBIENT TEMPERATURE**

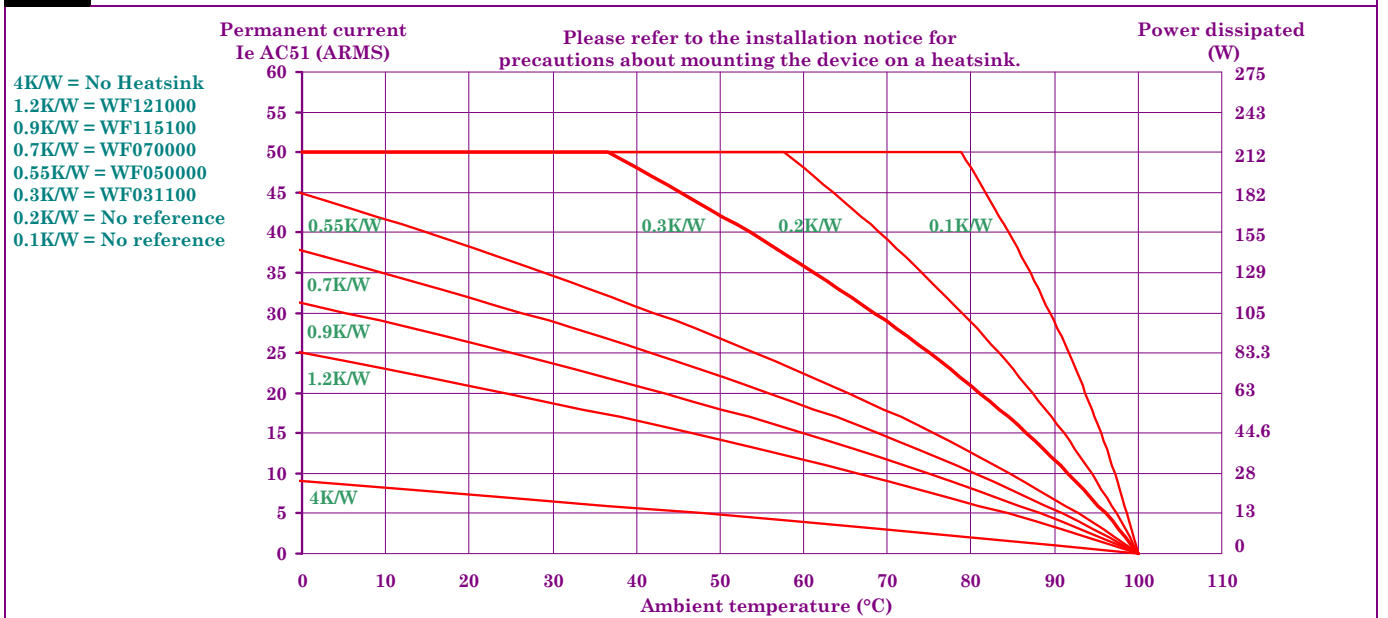

**Fig. 8 CURRENT OVERLOAD CHARACTERISTIC (ITSM PER POWER ELEMENT)**

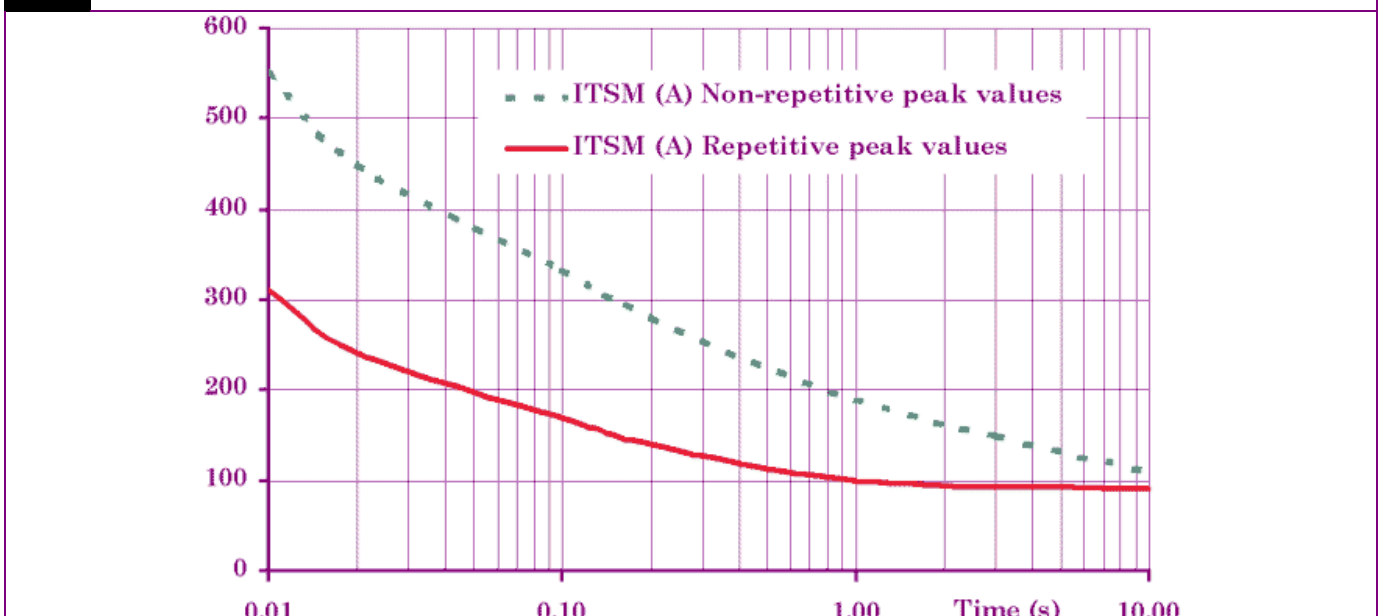



**DIMENSIONS AND ACCESSORIES**

Fig. 9

**DIMENSIONS**

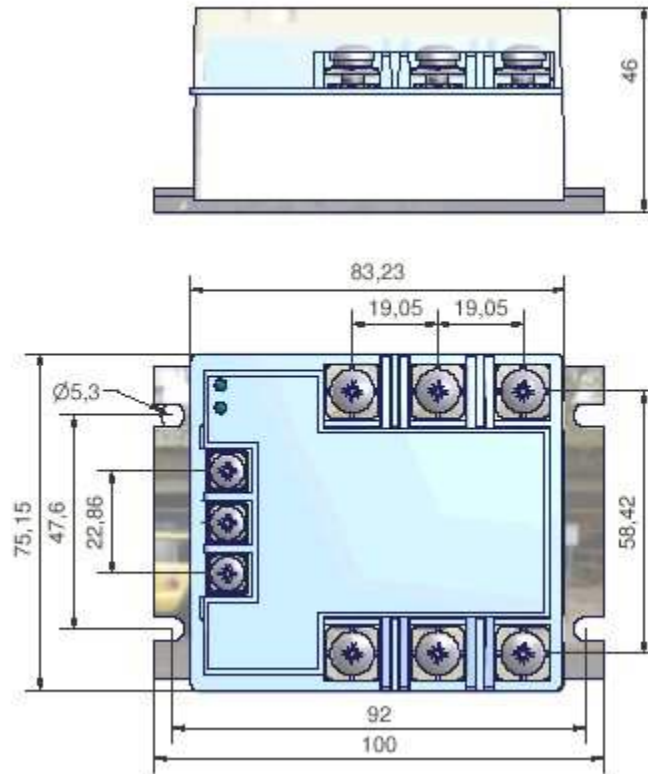
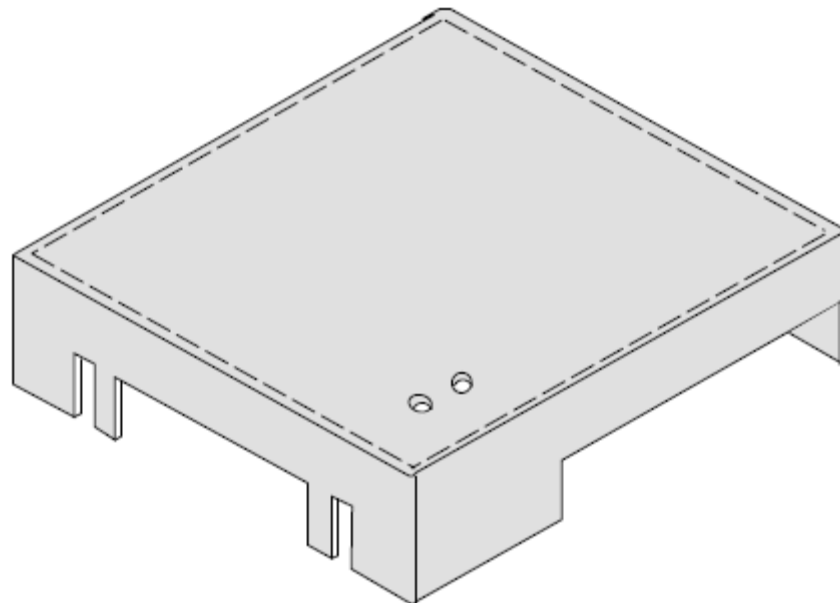

Fig. 10

**ACCESSORIES**



**Protective cover 1K199000**

