

3HE09498AA-C

Alcatel-Lucent Nokia® 3HE09498AA Compatible TAA 100GBase-LR4 CFP4 Transceiver (SMF, 1310nm, 10km, LC, DOM)

Features:

- CFP MSA 1.1 Compliance
- Duplex LC Connector
- Single-mode Fiber
- Commercial Temperature 0 to 70 Celsius
- Hot Pluggable
- Metal with Lower EMI
- Excellent ESD Protection
- RoHS Compliant and Lead Free



Applications:

- 100GBase Ethernet
- Access and Enterprise

Product Description

This Alcatel-Lucent Nokia® 3HE09498AA compatible CFP4 transceiver provides 100GBase-LR4 throughput up to 10km over single-mode fiber (SMF) using a wavelength of 1310nm via an LC connector. It is guaranteed to be 100% compatible with the equivalent Alcatel-Lucent Nokia® transceiver. This easy to install, hot swappable transceiver has been programmed, uniquely serialized and data-traffic and application tested to ensure that it will initialize and perform identically. Digital optical monitoring (DOM) support is also present to allow access to real-time operating parameters. This transceiver is Trade Agreements Act (TAA) compliant. We stand behind the quality of our products and proudly offer a limited lifetime warranty.

ProLabs' transceivers are RoHS compliant and lead-free.

TAA refers to the Trade Agreements Act (19 U.S.C. & 2501-2581), which is intended to foster fair and open international trade. TAA requires that the U.S. Government may acquire only "U.S. – made or designated country end products."



Absolute Maximum Ratings

Parameter	Symbol	Min.	Typ.	Max.	Unit	Notes
Storage Temperature	TS	-40		+85	°C	
Power Supply Voltage	VCC	0		+3.6	V	+3.3V
Operating Case Temperature Range	Tc	0	25	70	°C	
Optical Receiver Input	Pimax			+5.5	dBm	Average
Power Supply Noise	Vrip			2 3	% %	DC – 1MHz 1 – 10MHz

Optical Characteristics (Note 1)

Parameter	Symbol	Min.	Typ.	Max.	Unit	Notes
Transmitter						
Channel data rate	fDC		25.78125		Gbit/s	2
Aggregate data rate	fD		103.125		Gbit/s	2
Signal speed variation from nominal	ΔfD	-100		+100	ppm	2
Optical Center Wavelength	Lane 0	λ _{CT0}	1294.53		1296.59	nm
	Lane 1	λ _{CT1}	1299.02		1301.09	nm
	Lane 2	λ _{CT2}	1303.54		1305.63	nm
	Lane 3	λ _{CT3}	1308.09		1310.19	nm
Optical Output Power in OMA	OMA	-1.3		+4.5	dBm	3
Average Optical Output Power of Off Transmitter	P _{off}			-30	dBm	
Optical Waveform			Eye Diagram			2
Extinction Ratio	ER	4			dB	
Receiver						
Receiver Sensitivity in OMA	P _{minOMA}	-8.6		+4.5	dBm	
Stressed Receiver Sensitivity in OMA	P _{minSOMA}			-6.8	dBm	4
Receive Power, each lane in OMA				+4.5	dBm	

Notes:

1. Data Rate; NRZ, Mark Ratio 50%, PRBS=2³¹-1, 1x10⁻¹² BER unless otherwise specified.
2. Per IEEE 802.3ba specification
3. $OMA = 10 \log_{10} [2P \{ (A-1)/(A+1) \}]$, $A = 10^{(ER/10)}$, $P = 10^{(Pf/10)}$
4. Stressed Receiver Sensitivity measurement method is under study

Mask of Optical Output Eye Diagram

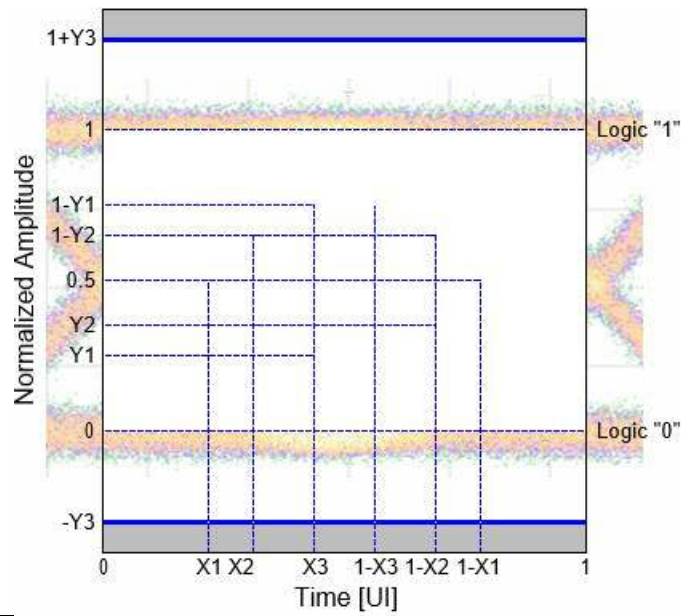

X1	X2	X3	Y1	Y2	Y3	Max hit ratio (Note)
0.25	0.4	0.45	0.25	0.28	0.4	5×10^{-5}

Note:

The acceptable ratio of samples inside to outside the hatched area (the “hit ratio”) must be met.

Electrical Characteristics

Parameter	Symbol	Min.	Typ.	Max.	Unit	Notes
Power Supply Voltage	VCC	3.2	3.3	3.4	V	
Supply Current	ICC			1.9	A	1
Supply Current @Low Power Mode	ICCL			0.3	A	
Power Consumption	P			6	W	
Power Consumption @Low Power Mode	P _{low}			1	W	
3.3V LVCMOS level						
Input High Voltage	V _{IH}	2		VCC + 0.3	V	
Input Low Voltage	V _{IL}	-0.3		0.8	V	
Input Leakage Current	I _{IN}	-10		+10	μA	
Output High Voltage	V _{OH}	VCC – 0.2			V	I _{OH} =-100μA
Output Low Voltage	V _{OL}			0.2	V	I _{OL} =100μA
Minimum Pulse Width of Control Pin Signal	t _{CNTL}	100				μs
1.2 VLVC MOS Level						
Input High Voltage	V _{IH}	0.84		1.5	V	
Input Low Voltage	V _{IL}	-0.3		0.36	V	
Input Leakage Current	I _{IN}	-100		+100	μA	
Output High Voltage	V _{OH}	1.0		1.5	V	
Output Low Voltage	V _{OL}	-0.3		0.2	V	
Output High Current	I _{OH}			-4	mA	
Output Low Current	I _{OL}	+4			mA	
Input capacitance	C _i			10	pF	

Notes:

1. Maximum module current ramp rate is 100 mA /μs.

3.3V LVCMOS Interface

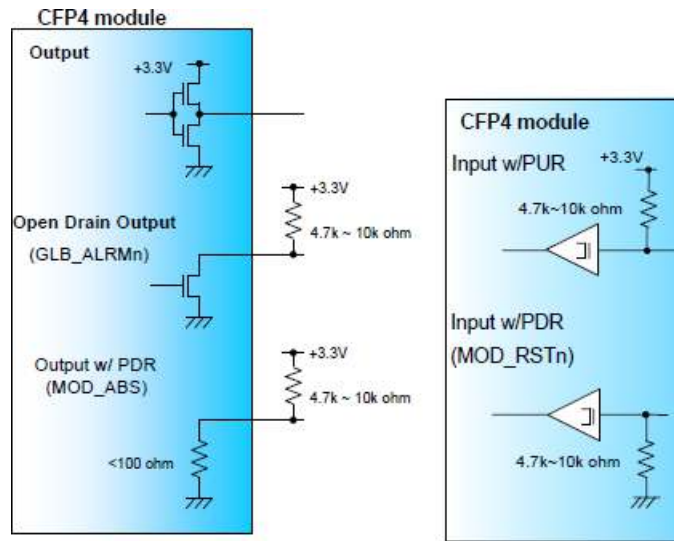

MDIO Interface

The below drawings, with maximum host load capacitance of 200pF, also define the measurement set-up for module MDC timing verification. The capacitor in the drawing indicates the stray capacitance on the line. Don't put any physical capacitor on the line.

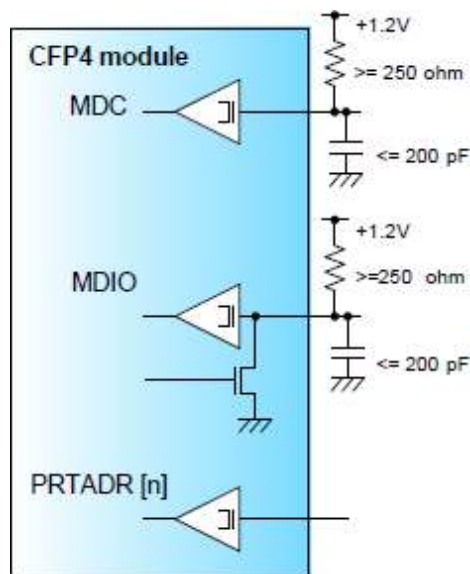

High Speed Electrical Input Characteristics

Parameter	Symbol	Min.	Max.	Unit	Conditions
Differential Voltage Overload pk-pk	Module Input	900		mV	Calibrated at TP1a
Differential Termination Mismatch	Module Input		10	%	at 1 MHz
Differential Return Loss	Module Input		Note 1	dB	
Common Mode to differential conversion Loss	Host Output	Note 2		dB	

Notes:

- SDD11, SDD22 < -11dB for $f < f_b/7$, SDD11, SDD22 < $-6.0 + 9.2 \cdot \log(2f/f_b)$ dB for $f_b/7 < f < f_b$ ($f_b = 25.78$ GHz)
- SDC11 < $-25 + 20 \cdot (f/f_b)$ dB for $f < f_b/2$, SDC11 < -15 dB for $f_b/2 < f < f_b$ ($f_b = 25.78$ GHz)

High Speed Electrical Output Characteristics

Parameter	Direction	Min.	Max.	Unit	Conditions
Differential Voltage, pk-pk	Module Output		900	mV	
Common Mode Noise, rms	Module Output		17.5	mV	
Differential Termination Mismatch	Module Output		10	%	at 1 MHz
Differential Return Loss	Module Output		Note 1	dB	
Transition Time: 20/80%	Module Output	9.5		ps	
Vertical Eye Closure (VEC)			6.5	dB	
Eye width at 10-15 probability (EW15)	Module Output	0.57		UI	
Eye height at 10-15 probability (EH15)	Module Output	240		mV	

Notes:

- SDD11, SDD22 < -11dB for $f < f_b/7$, SDD11, SDD22 < $-6.0 + 9.2 \cdot \log(2f/f_b)$ dB for $f_b/7 < f < f_b$ ($f_b = 25.78$ GHz)

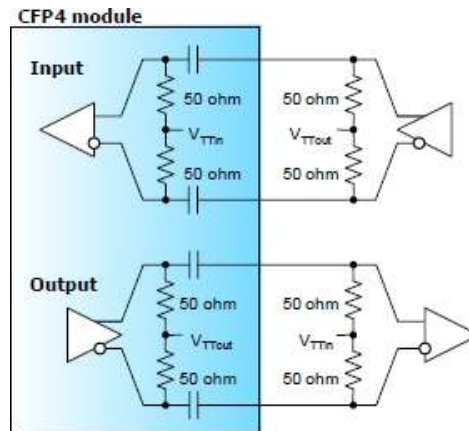

High speed I/O for Data and Clocks

Transmitter & Receiver Monitor Clock Characteristics

Parameter	Symbol	Min.	Typ.	Max.	Unit	Remarks
Clock Differential Input Impedance	Zd	80	100	120	ohm	
Differential Output Clock Amplitude	V _{DIFF}	400		1200	mVpp	AC coupled CML
Reference Clock Duty Cycle		40		60	%	

Optical signal, Electrical signal, MCLK and REFCLK frequency relation

Parameter	Symbol	Rate	Unit	Remarks
Aggregate data rate	f _{DC}	103.125	Gbit/s	
Optical signal rate per lane (Channel data rate)	f _D	25.78125	Gbit/s	f _{DC} /4
Electrical signal rate per lane	f _{host}	25.78125	Gbit/s	
TXMCLK rate	f _m	1/8 of network lane rate (3.22266 GHz) or 1/32 of network lane rate (805.665 MHz)		Default: Disabled Note 1
RXMCLK rate	f _m	1/8 of network lane rate (3.22266 GHz) or 1/32 of network lane rate (805.665 MHz)		Default: disabled
REFCLK rate	f _o	161.1328 (f _{host} /160)	MHz	MDIO reg. Selectable

Notes:

1. For optical signal measurement trigger

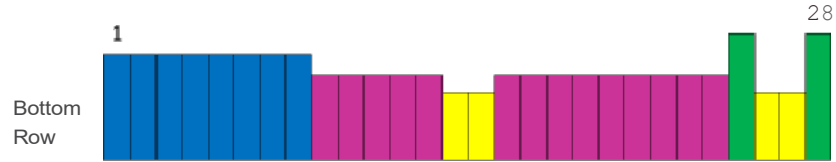
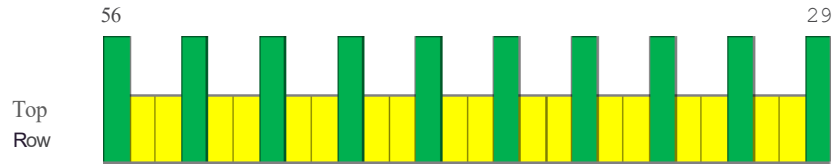

Engagement Category █ 3rd

CFP4	
Bottom	
1	3.3V GND
2	3.3V GND
3	3.3V
4	3.3V
5	3.3V
6	3.3V
7	3.3V GND
8	3.3V GND
9	VND 10 A
10	VND 10 B
11	TX DIS (PRG CNTL1)
12	RX LOS (PRG ALRM1)
13	GLB ALRMn
14	MOD LOPWR
15	MOD ABS
16	MOD RSTn
17	MDC
18	MDIO
19	PRTADR0
20	PRTADR1
21	PRTADR2
22	VND 10 C
23	VND 10 D
24	VND 10 E
25	GND
26	I/MCLKnJ
27	I/MCLKDI
28	GND

CFP4	
Top	
56	GND
55	TX3n
54	TX3o
53	GND
52	TX2n
51	TX2p
50	GND
49	TX1n
48	TX1o
47	GND
46	TX0n
45	TX0p
44	GND
43	(REFCLKnJ)
42	(REFCLKp)
41	GND
40	RX3n
39	RX3p
38	GND
37	RX2n
36	RX2o
35	GND
34	RX1n
33	RX1p
32	GND
31	RX0n
30	RX0p
29	GND

Pin Descriptions

PIN	Name	I/O	Logic	Description
1	3.3V_GND			3.3V Module Supply Voltage Return Ground, can be separated or tied together with Signal Ground
2	3.3V_GND			
3	3.3V			
4	3.3V			
5	3.3V			
6	3.3V			3.3V Module Supply Voltage
7	3.3V_GND			
8	3.3V_GND			
9	VIND_IO_A	I/O		Module Vendor I/O A. Do Not Connect
10	VIND_IO_B	I/O		Module Vendor I/O B. Do Not Connect
11	TX_DIS (PRG_CNT L1)	I	LVC MOS w/PUR	Transmitter Disable for all lanes. "1" or NC: Transmitter disabled; "0": transmitter enabled. (Optionally configurable as Programmable Control1 after Reset)
12	RX_LOS (PRG_ALR M1)	O	LVC MOS w/PUR	Receiver Loss of Optical Signal. "1": low optical signal; "0": normal condition (Optionally configurable as Programmable Alarm1 after Reset)
13	GLB_ALR M	O	LVC MOS	Global Alarm. "0": alarm condition in any MDIO Alarm register; "1": no alarm condition, Open Drain, Pull up Resistor on Host
14	MOD_LOP WR	I	LVC MOS w/PUR	Module Low Power Mode. "1" or NC: module in low power (safe) mode; "0": power-on enabled
15	MOD_ABS	O	GND	Module Absent. "1" or NC: module absent; "0": module present, Pull up resistor on Host
16	MOD_RSTn	I	LVC MOS w/PDR	Module Reset. "0": resets the module; "1" or NC: module enabled, Pull down Resistor in Module
17	MDC	I	1.2V CMOS	Management Data Clock (electrical specs as per IEEE Std 802.3-2012)
18	MDIO	I/O	1.2V CMOS	Management Data I/O bi-directional data (electrical specs as per IEEE Std 802.3ae-2008 and ba-2010)
19	PRTADR0	I	1.2V CMOS	MDIO Physical Port address bit 0
20	PRTADR1	I	1.2V CMOS	MDIO Physical Port address bit 1
21	PRTADR2	I	1.2V CMOS	MDIO Physical Port address bit 2
22	VND_IO_C	I/O		Module Vendor I/O C. Do Not Connect
23	VND_IO_D	I/O		Module Vendor I/O D. Do Not Connect
24	VND_IO_E	I/O		Module Vendor I/O E. Do Not Connect
25	GND			
26	(MCLKn)	O	CML	For optical waveform testing. Not for normal use
27	(MCLKp)	O	CML	For optical waveform testing. Not for normal use
28	GND			

BOTTOM VIEW OF MODULE

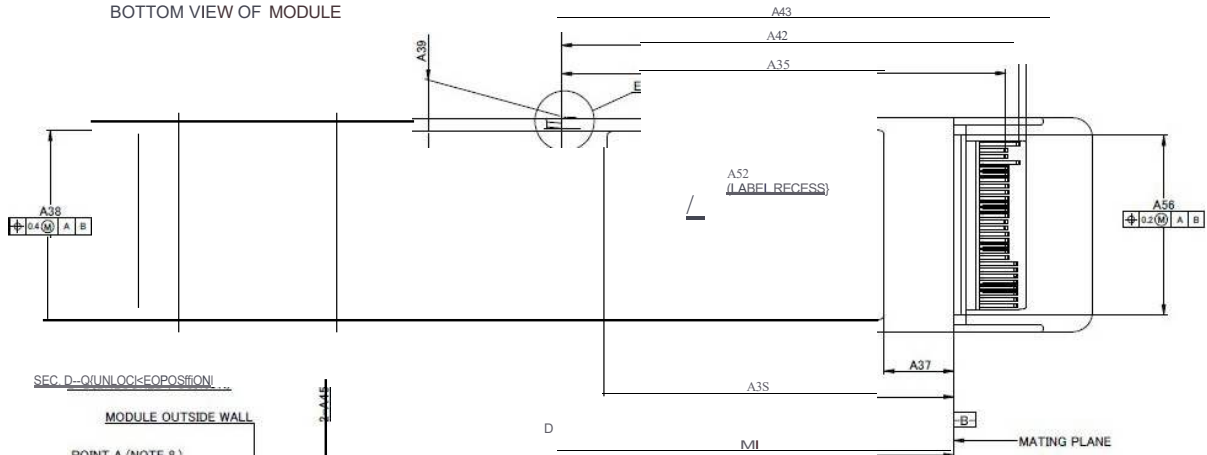

SEC. D-Q (UNLOCKED POSITION)

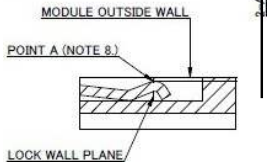

DETAIL E

(CUTOUT FOR DATUM "0"-INSPECTION)

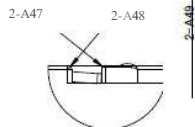

SEC. D-Q (LOCKED POSITION)

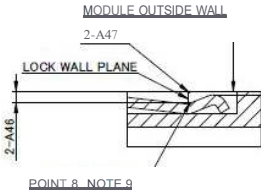

NOTE

1. 7deg C MAXIMUM TEMPERATURE DELTA WITH NO HEATSINK AND 200LFM SIDEWAYS AIR FLOW. (DELTA TEMPERATURE SPECIFICATION TO SEVERE CASE WITH FIRST ARTICLES).
2. DRAFT ANGLE TO BE IN THE DECREASING MASS DIRECTION.
3. MODULE LATCH POSITION MUST INTEROPERATE WITH CFP4 CAGE SPECIFICATIONS.
4. SURFACE FLATNESS: "F" IS SPECIFIED IN CFP4 HARDWARE SPECIFICATION.
5. SURFACE ROUGHNESS: "R" IS SPECIFIED IN CFP4 HARDWARE SPECIFICATION.
6. DIMENSION APPLIES TO LATCH MECHANISM.
7. MAXIMUM OUTSIDE ENVELOPE BETWEEN TWO OPPOSITE LATCHES.
8. "POINT A" IS AT THE VIRTUAL INTERSECTION OF LOCK WALL PLANE AND OUTER SURFACE OF LATCH.
9. "POINT B" IS AT THE VIRTUAL INTERSECTION OF LOCK WALL PLANE AND OUTER SURFACE OF LATCH.
10. GASKET TO MEET MINIMUM PEELS STRENGTH : 30 Oz/in or 335 gf/cm per ASTM 03330 test method.

About ProLabs

Our experience comes as standard; for over 15 years ProLabs has delivered optical connectivity solutions that give our customers freedom and choice through our ability to provide seamless interoperability. At the heart of our company is the ability to provide state-of-the-art optical transport and connectivity solutions that are compatible with over 90 optical switching and transport platforms.

Complete Portfolio of Network Solutions

ProLabs is focused on innovations in optical transport and connectivity. The combination of our knowledge of optics and networking equipment enables ProLabs to be your single source for optical transport and connectivity solutions from 100Mb to 400G while providing innovative solutions that increase network efficiency. We provide the optical connectivity expertise that is compatible with and enhances your switching and transport equipment.

Trusted Partner

Customer service is our number one value. ProLabs has invested in people, labs and manufacturing capacity to ensure that you get immediate answers to your questions and compatible product when needed. With Engineering and Manufacturing offices in the U.K. and U.S. augmented by field offices throughout the U.S., U.K. and Asia, ProLabs is able to be our customers best advocate 24 hours a day.



Contact Information

ProLabs US

Email: sales@prolabs.com

Telephone: 952-852-0252

ProLabs UK

Email: salessupport@prolabs.com

Telephone: +44 1285 719 600