

PHOTONIC DETECTORS INC.

High-Speed GaAlAs Infrared Point Source Emitter Peak Wavelength 850 nm, Type PDI-E822

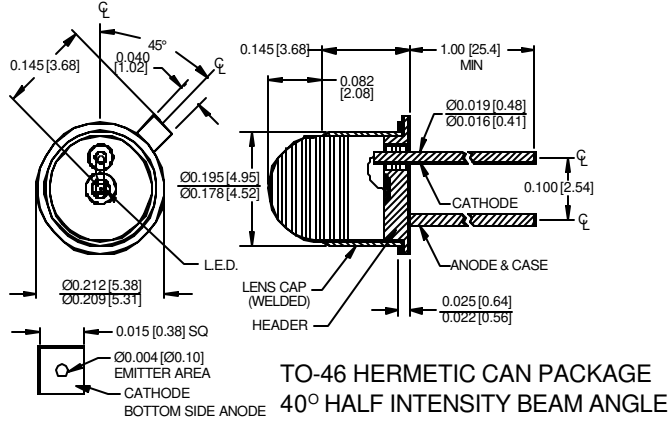

PACKAGE DIMENSIONS inch (mm)



FEATURES

- High speed
- High reliability
- Medium emission angle

DESCRIPTION: The PDI-E822 is a GaAlAs, 850 nm, high speed point source emitter. The emitting junction is .004 inch (0.10 mm) diameter. The topside metal cathode forms an optical aperture mask. Packaged in a TO-46 header with a glass lens cap.

APPLICATIONS

- Fiber optic sources
- Optical encoders
- Point light sources

ABSOLUTE MAXIMUM RATING (TA=25°C unless otherwise noted)

SYMBOL	PARAMETER	MIN	MAX	UNITS
Pd	Power Dissipation		200	mW
I _{FP}	Continuous Forward Current		100	mA
I _{FP}	Peak Forward Current (10μs, 10Hz)		2.5	A
V _R	Reverse voltage		2	V
To & Ts	Storage & Operating Temperature	-55	+125	°C
TS	Soldering Temperature*		+260	°C

*1/16 inch from case for 3 secs max

TYPICAL RADIATION PATTERN

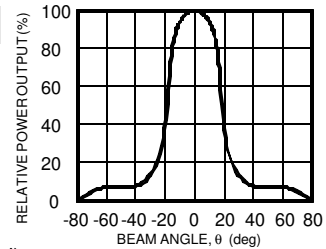

ELECTRO-OPTICAL CHARACTERISTICS (TA=25°C unless otherwise noted)

SYMBOL	CHARACTERISTIC	TEST CONDITIONS	MIN	TYP	MAX	UNITS
P _o	Output Power	I _F = 100 mA	2.5			mW
V _F	Forward Voltage	I _F = 100 mA		1.70	2.2	V
V _R	Reverse Breakdown Voltage	I _F = 10 μA	2.0			V
λ _p	Peak Wavelength	I _F = 20 mA	830	850	870	nm
Δλ	Spectral Halfwidth	I _F = 20 mA		30		nm
C _t	Terminal Capacitance	V _R = 0 V, f = 1 MHz		60		pF
t _r	Rise Time	I _F = 20 mA		15		nS
t _f	Fall Time	I _F = 20 mA		15		nS

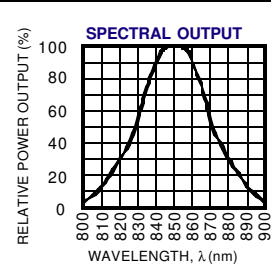
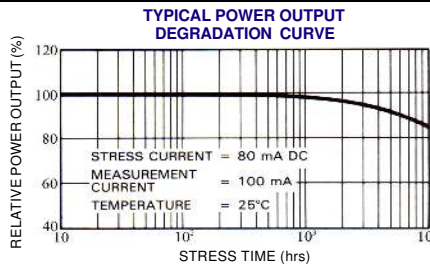
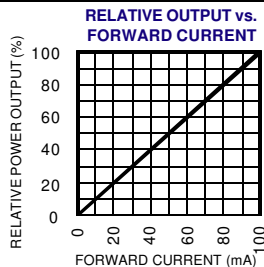

Information in this technical data sheet is believed to be correct and reliable. However, no responsibility is assumed for possible inaccuracies or omission. Specifications are subject to change without notice. Optical power and radiant intensity measured using uncapped dimpled TO-46 into integrating sphere.