

- 1
- 2
- 3
- 4
- 5
- 6
- 7
- 8
- 9
- 10
- 11
- 12
- 13
- 14
- 15
- 16
- 17
- 18

MATERIAL

Glass-fibre reinforced polyamide based (PA) technopolymer, grey-black colour, matte finish.

CAP

Technopolymer in Ergostyle colours, matte finish. Ultrasonically welded to the body of the knob.

STANDARD EXECUTIONS

Brass boss with tapped or plain blind hole.

ERGONOMY AND DESIGN

The slightly concave front surface and the rear finger grips guarantee an ergonomic position of the hand, allowing the operator to apply the maximum torque with the minimum force.

OTHER EXECUTIONS ON REQUEST

Metric plain or tapped hole.



ERGOSTYLE® ELESA Original design

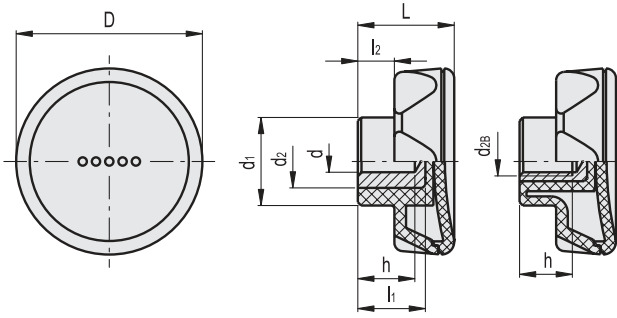

* Complete with colour index, example: 90221206-C2 ELK.45 B-1/4-C2

- C1** RAL7021
- C2** RAL2004
- C3** RAL7035
- C4** RAL1021
- C5** RAL5024
- C6** RAL3000
- C17** RAL6017

Code	Description	D	d	dB	L	d1	d2	l1	l2	h	Δ
90221206-*	ELK.45 B-1/4-*	1.77	0.250	-	1.02	0.83	0.55	0.75	0.39	0.55	0.09
90221221-*	ELK.45 B-1/4-20-*	1.77	-	1/4-20	1.02	0.83	-	-	0.39	0.47	0.07
90221406-*	ELK.56 B-5/16-*	2.2	0.312	-	1.14	1.04	0.55	0.71	0.43	0.55	0.13
90221426-*	ELK.56 B-5/16-18-*	2.2	-	5/16-18	1.14	1.04	-	-	0.43	0.51	0.1
90221606-*	ELK.70 B-3/8-*	2.76	0.375	-	1.38	1.28	0.87	0.98	0.51	0.83	0.27
90221631-*	ELK.70 B-3/8-16-*	2.76	-	3/8-16	1.38	1.28	-	-	0.51	0.71	0.17

Clamping knobs