

- **Ideal for 318 MHz Automotive-Keyless-Entry Transmitters**
- **Very Low Series Resistance**
- **Quartz Stability**
- **Complies with Directive 2002/95/EC (RoHS)**
- **Tape and Reel Standard per ANSI/EIA-481**
- **Moisture Sensitivity Level: 1**

The RO3118E-1 is a true one-port, surface-acoustic-wave (SAW) resonator in a surface-mount, ceramic case. It provides reliable, fundamental-mode, quartz frequency stabilization of local oscillators operating at approximately 318 MHz.

Absolute Maximum Ratings

Rating	Value	Units
Input Power Level	0	dBm
DC Voltage	12	VDC
Storage Temperature Range	-40 to +125	°C
Operating Temperature Range	-40 to +105	°C
Soldering Temperature (10 seconds / 5 cycles max.)	260	°C

RO3118E-1

318.0 MHz

SAW Resonator

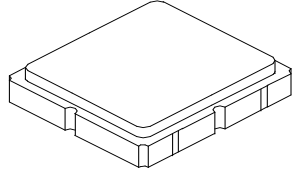

SM3030-6 Case

3.0 X 3.0

Characteristic		Sym	Notes	Minimum	Typical	Maximum	Units
Frequency (+25 °C)	Absolute Frequency	f _C		317.950		318.050	MHz
	Tolerance from 315.0 MHz	Δf _C				±50	kHz
Insertion Loss		IL			1.6	2.2	dB
Quality Factor	Unloaded Q	Q _U			9000		
	50W Loaded Q	Q _L			1500		
Temperature Stability	Turnover Temperature	T _O		10	25	40	°C
	Turnover Frequency	f _O			f _C		
	Frequency Temperature Coefficient	FTC			0.032		ppm/°C ²
Frequency Aging	Absolute Value during the First Year	f _A			10		ppm/yr
DC Insulation Resistance between Any Two Terminals				1.0			MΩ
RF Equivalent RLC Model	Motional Resistance	R _M			21		Ω
	Motional Inductance	L _M			93		μH
	Motional Capacitance	C _M			2.7		fF
	Shunt Static Capacitance	C _O			2.8		pF
Test Fixture Shunt Inductance		L _{TEST}			89		nH
Lid Symbolization: Y = Year, WW = Week, S = Shift				765, YWWS			
Standard Reel Quantity	Reel Size 7 Inch			500 Pieces / Reel			
	Reel Size 13 Inch			3000 Pieces / Reel			

 **CAUTION: Electrostatic Sensitive Device. Observe precautions for handling.**

NOTES:

1. The design, manufacturing process, and specifications of this device are subject to change.
2. US or International patents may apply.
3. RoHS compliant from the first date of manufacture.

Electrical Connections

The SAW resonator is bidirectional and may be installed with either orientation. The two terminals are interchangeable and unnumbered. The callout NC indicates no internal connection. The NC pads assist with mechanical positioning and stability. External grounding of the NC pads is recommended to help reduce parasitic capacitance in the circuit.

Pin	Connection
1	NC
2	Terminal
3	NC
4	NC
5	Terminal
6	NC

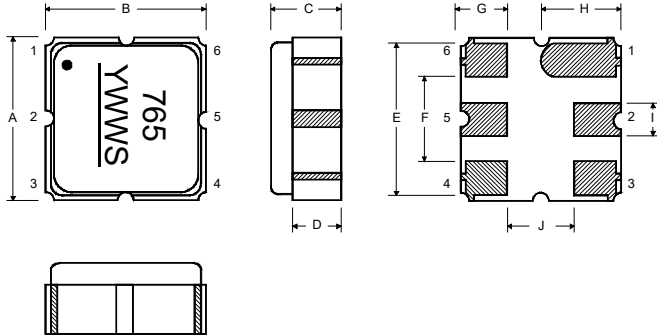

Case Dimensions

Dimension	mm			Inches		
	Min	Nom	Max	Min	Nom	Max
A	2.87	3.0	3.13	0.113	0.118	0.123
B	2.87	3.0	3.13	0.113	0.118	0.123
C	1.12	1.25	1.38	0.044	0.049	0.054
D	0.77	0.90	1.03	0.030	0.035	0.040
E	2.67	2.80	2.93	0.105	0.110	0.115
F	1.47	1.6	1.73	0.058	0.063	0.068
G	0.72	0.85	0.98	0.028	0.033	0.038
H	1.37	1.5	1.63	0.054	0.059	0.064
I	0.47	0.60	0.73	0.019	0.024	0.029
J	1.17	1.30	1.43	0.046	0.051	0.056

Typical Test Circuit

The test circuit inductor, L_{TEST} , is tuned to resonate with the static capacitance, C_O , at F_C .

Electrical Test

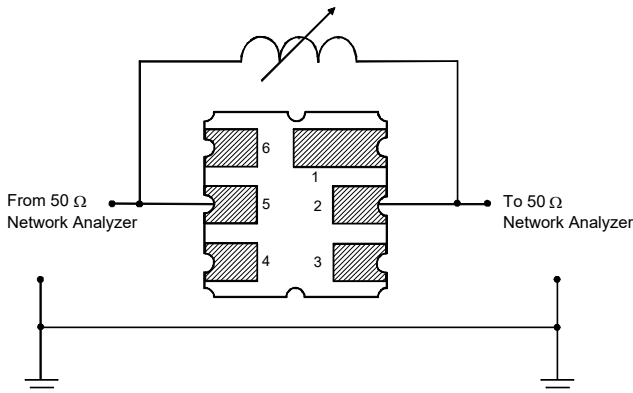

Power Test

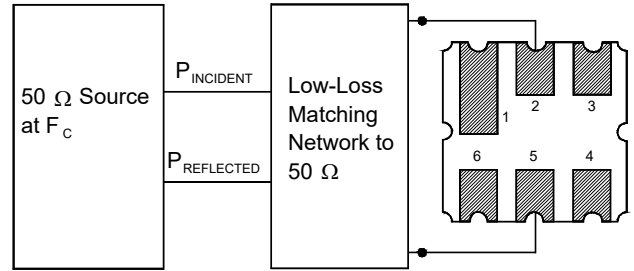

Typical Application Circuits

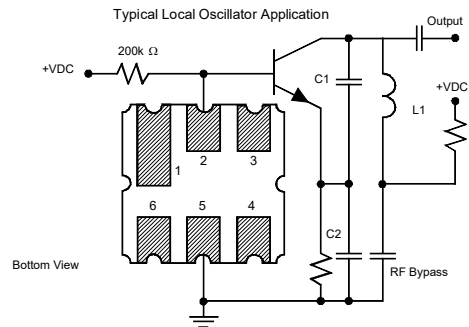
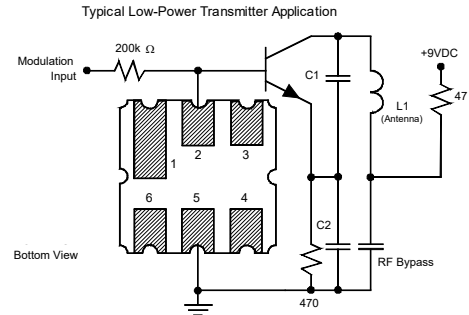

Equivalent LC Model

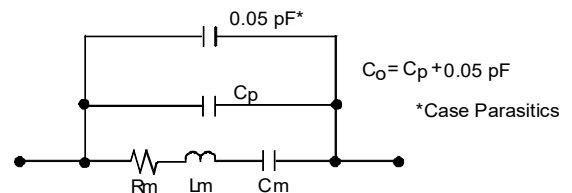

Temperature Characteristics

The curve shown on the right accounts for resonator contribution only and does not include LC component temperature contributions.

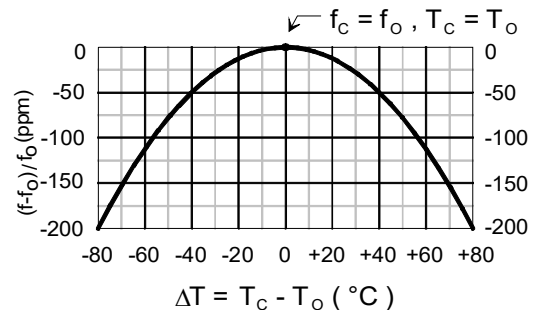

Recommended Reflow Profile

1. Preheating shall be fixed at 150~180°C for 60~90 seconds.
2. Ascending time to preheating temperature 150°C shall be 30 seconds min.
3. Heating shall be fixed at 220°C for 50~80 seconds and at 260°C +0/-5°C peak (10 seconds).
4. Time: 5 times maximum.

