



MAX5960L Evaluation Kit/ Evaluation System

General Description

The MAX5960L evaluation kit (EV kit) is a fully assembled and tested surface-mount quad hot-plug controller printed-circuit board (PCB) with four PCI Express® hot-plug slots. The circuit uses a MAX5960L IC in an 80-pin TQFP package. The EV kit provides independent power control for the 12V, 3.3V, and 3.3V auxiliary outputs at four PCI Express x16 connectors. The EV kit demonstrates the MAX5960L IC's inrush current control, output overcurrent/short-circuit protection, and input undervoltage monitoring features.

The MAX5960L IC controls two separate external n-channel MOSFETs for the 12V and 3.3V outputs of each channel, respectively. Additionally, the MAX5960L has internal MOSFETs that control the 3.3V auxiliary outputs of channels A, B, C, and D. Switches are provided to independently enable/disable each channels' main (12V, 3.3V) and auxiliary supply (3.3V).

The MAX5960L EV kit can be reconfigured for evaluating a x1, x4, or x8 PCI Express quad hot-plug design. Alternatively, the EV kit can also be used to demonstrate the MAX5960L hot-plug features without using the PCI Express x16 connectors.

The EV kit includes three MAX7313 I/O expanders that enable communication through an SMBus™ interface for the MAX5960L signals and some of the PCI Express channel signals. A CMAXQUSB interface board can be used to enable PC communication through the SMBus interface. Simple Windows® 98SE/2000/XP-compatible software is provided to access each MAX7313 I/O expander register at the bit level. The MAX5960L EV kit can also be used in local control, without any software.

Order the MAX5960LEVCMAXQU for a complete PC-based evaluation of the MAX5960L. Order the MAX5960LEVKIT if you already have a CMAXQUSB interface board or do not require PC-based evaluation of the MAX5960L.

PCI Express is a registered trademark of PCI-SIG Corp.

SMBus is a trademark of Intel Corp.

Windows is a registered trademark of Microsoft Corp.

Features

- ◆ Demonstrates PCI Express x16 Quad Hot-Plug Design
- ◆ Independent Output Controls for Each Channel
 - 12V and Up to 5.5A (Adjustable)
 - 3.3V and Up to 3.3A (Adjustable)
 - 3.3VAUX and Up to 0.550A
- ◆ Evaluates Hot-Plugging PCI Express x1, x4, x8, or x16 Line Cards
- ◆ Demonstrates Input Inrush Current Control
- ◆ Demonstrates Output Overcurrent/Short-Circuit Protection
- ◆ Undervoltage Lockout Protection for 12V, 3.3V, and 3.3V Auxiliary Supplies
- ◆ Configurable Power-On Reset (POR)
- ◆ Independent On/Off Controls for Each Channel's 12V/3.3V Main and 3.3V Aux Power
- ◆ Latched Output (MAX5960L) after Fault Conditions; also Evaluates MAX5959A, MAX5960A Autoretry
- ◆ Input/Output Interface Using MAX7313 I/O Expanders (SMBus Interface) or Local Control
- ◆ Can Be Controlled Locally Without Software
- ◆ Windows 98SE/2000/XP-Compatible Software
- ◆ Fully Assembled and Tested

Ordering Information

PART	TYPE
MAX5960LEVKIT+	EV Kit
MAX5960LEVCMAXQU+	EV System

+Denotes lead-free and RoHS-compliant.

Note: The MAX5960L EV kit software can be downloaded from the Maxim website at www.maxim-ic.com/evkitssoftware. However, the CMAXQUSB interface board is required to interface the EV kit to a computer when using the software.



MAX5960L Evaluation Kit/ Evaluation System

Component Lists

MAX5960L EV System

PART	QTY	DESCRIPTION
MAX5960LEVKIT+	1	MAX5960L evaluation kit
CMAXQUSB+	1	SMBus interface board

MAX5960L EV Kit

DESIGNATION	QTY	DESCRIPTION
C1, C3, C40, C41, C42	5	0.1 μ F \pm 10%, 16V X7R ceramic capacitors (0603) Murata GRM188R71C104K
C2, C4, C11, C14, C17, C20, C24, C25, C28, C30	0	Not installed, ceramic capacitors (0805)
C5, C10, C15, C16, C21, C22, C23, C26, C27, C31–C34	13	1 μ F \pm 10%, 16V X7R ceramic capacitors (0805) Murata GRM21BR71C105K
C12, C18, C29	3	10 μ F \pm 20%, 25V X7R ceramic capacitors (1812) TDK 4532X7R1E106M
C13	1	1500 μ F, 16V electrolytic capacitor (12.5mm x 13.5mm case) Panasonic EEVFK1C152Q
C19	1	3300 μ F, 6.3V, low-Z electrolytic capacitor (12.5mm x 13.5mm case) SANYO 6CE3300KX
C35	1	100 μ F, 6.3V, low-Z electrolytic capacitor (6.3mm x 6.0mm case) SANYO 6CE100KX
D1	1	1A, 40V Schottky diode (SOD-123) Diodes Inc. 1N5819HW-F
D2–D14, D17, D18, D21	16	Green surface-mount LEDs (1206)
D15, D16, D19, D20	4	Yellow surface-mount LEDs (1206)
J1–J4	4	PCI Express x16 connectors Molex 87715-9305
J5–J8	4	8-pin headers
J9	1	2 x 10 right-angle female receptacle

MAX5960L EV Kit (continued)

DESIGNATION	QTY	DESCRIPTION
JU1–JU4, JU9, JU10, JU15, JU16	8	2-pin headers
JU5–JU8, JU11–JU14	8	3-pin headers
N1–N8	8	20V, 13.4A n-channel MOSFETs (8-pin SO) Vishay Si7448DP-T1-E3
R1–R6, R11–R16, R73, R76, R82, R83, R84, R90, R93, R99–R104	25	10k Ω \pm 5% resistors (0603)
R7–R10, R17, R18	0	Not installed, resistors (0603)
R30, R36, R45, R50	4	1k Ω \pm 5% resistors (1206)
R31, R35, R38, R42, R46, R49, R52, R55	0	Not installed, resistors (0805)
R32, R34, R47, R48	4	0.008 Ω \pm 1%, 0.5W sense resistors (2010) Vishay WSL20108L000FEA or IRC LRC-LRF2010LF-01-R008-G
R33	1	750 Ω \pm 1% resistor (1210)
R37, R41, R43, R44, R51, R56, R57, R58, R74, R75, R80, R81, R91, R92, R97, R98	16	150 Ω \pm 5% resistors (0603)
R39, R40, R53, R54	4	0.005 Ω \pm 1%, 0.5W sense resistors (2010) Vishay WSL20105L000FEA
R70, R71, R78, R79, R88, R89, R95, R96	8	51k Ω \pm 5% resistors (0603)
R72, R77, R94, R111	4	3.3k Ω \pm 5% resistors (0603)
SW1–SW4	4	SPST momentary-contact switches
SW5–SW12	8	SPDT slide switches

MAX5960L Evaluation Kit/ Evaluation System

MAX5960L EV Kit (continued)

DESIGNATION	QTY	DESCRIPTION
TP3, TP5, TP7, TP8, TP20, TP22, TP25, TP26, TP28, TP30, TP32, TP33, TP34, TP37, TP38, TP40, TP43, TP44, TP45, OUT1-OUT4	23	PC test points, red
TP11-TP18, TP23, TP29, TP41, TP46, TP47, TP48, TP53, TP54	16	PC test points, black
TP21, TP24, TP27, TP31, TP35, TP36, TP39, TP42, TP50, TP51	10	PC test points, miniature, red

DESIGNATION	QTY	DESCRIPTION
U1	1	Quad PCI Express hot-swap controller (80-pin TQFP 12mm x 12mm x 1mm) Maxim MAX5960LECS+
U2, U3, U4	3	Maxim 16-port I/O expanders (24-pin thin QFN, 4mm x 4mm) MAX7313ATG+
VIN1, VIN2, VIN3, GND, GND	5	Uninsulated banana jacks
—	16	Shunts (JU1-JU16)
—	10	Rubber bumpers
—	1	PCB: MAX5960L Evaluation Kit+

Component Suppliers

SUPPLIER	PHONE	WEBSITE
Diodes Inc.	805-446-4800	www.diodes.com
IRC	361-992-7900	www.irctt.com
Murata	770-436-1300	www.murata.com
Panasonic	714-373-7366	www.panasonic.com
SANYO Electronic Device	619-661-6835	www.sanyodevice.com
TDK	847-803-6100	www.component.tdk.com
Vishay	—	www.vishay.com

Note: Indicate that you are using the MAX5959A/MAX5959L/MAX5960A/MAX5960L when contacting these component suppliers.

MAX5960L EV Kit Files

FILE	DESCRIPTION
INSTALL.EXE	Installs the EV kit files on your computer
MAX5960L.EXE	Application program
HELPPFILE.HTM	MAX5960L EV kit help file
FTD2XX.INF	USB device driver file
TROUBLESHOOTING_USB.PDF	USB driver installation help file
UNINST.INI	Uninstalls the EV kit software

Quick Start (Hardware Only)

Required equipment:

- One each of the following DC power supplies:
 - 12V, 25A
 - 3.3V, 20A
- Three voltmeters

The 3.3V power supply can be used to power the main 3.3V and 3.3VAUX inputs.

The MAX5960L EV kit is fully assembled and tested. Follow these steps to verify board operation. Do not turn on the power supply until all connections are completed.

Note the banana leads connecting the 12V and 3.3V power supply to the EV kit must be short (< 12in long) and rated for at least 25A.

MAX5960L Evaluation Kit/ Evaluation System

MAX5960L Hardware Only Configuration

- 1) Verify that shunts are installed on jumpers JU1, JU2, JU3, and JU4 (PRES-DET_).
- 2) Verify that shunts are installed on pins 1 and 2 of jumpers JU5, JU6, JU7, JU8, JU11, JU12, JU13, and JU14 (local switch control).
- 3) Verify that a shunt is not installed on jumpers JU9, JU10, JU15, and JU16 (MRL_).
- 4) Utilizing short 25A-rated banana leads (< 12in long) connect the 12V DC power supply to the VIN1 banana jack. Utilizing short 25A-rated banana leads (< 12in long) connect the supply ground to the GND banana jack.
- 5) Utilizing short 25A-rated banana leads (< 12in long) connect the 3.3V DC power supply to the VIN2 banana jack. Utilizing short 25A-rated banana leads (< 12in long) connect the supply ground to the GND banana jack.
- 6) Connect the 3.3V DC power supply to the VIN3 banana jack with a short banana lead.
- 7) Connect a voltmeter to the 12VA pad and GND. Connect a voltmeter to the 3.3VA pad and GND. Connect a voltmeter to the 3.3VAUXA pad and GND.
- 8) Set switches SW5, SW7, SW9, SW11 (ON_), and SW6, SW8, SW10, SW12 (AUXON_) to the OFF position.
- 9) Turn on both power supplies in any sequence.
- 10) Set switches SW5 (ONA) and SW6 (AUXONA) to the ON position.
- 11) Verify that the voltage at channel A pad is as shown below:
 - 12VA = 12V
 - 3.3VA = 3.3V
 - 3.3VAUXA = 3.3V
- 12) Sliding switches SW5 and SW6 to the OFF position will disable the channel A main or auxiliary outputs on the MAX5960L EV kit.
- 13) For evaluating channels B, C, and D, use analogous actions on steps 10 through 12 above for the respective channel switch setting and output voltage reading. See the *Jumper and Switch Selection* section for more information on configuring the respective channel.
- 14) Test points are provided to observe the MOSFET's gate voltage respectively with an oscilloscope.

Software and Hardware Quick Start

The MAX5960L EV kit is fully assembled and tested. Follow these steps to verify board operation. Do not turn on the power supplies until all connections are completed.

Required Equipment

- One each of the following DC power supplies:
 - 12V, 25A
 - 3.3V, 20A (used to power the main 3.3V and 3.3VAUX inputs)
- Maxim MAX5960L EV kit and CMAXQUSB interface board (USB cable included)
- Windows 98SE/2000/XP computer with a spare USB port
- Three voltmeters for confirming output voltages

Note: In the following sections, software-related items are identified by bolding. Text in **bold** refers to items directly from the EV kit software. Text in **bold and underlined** refers to items from the Windows operating system.

MAX5960L Software and Hardware Configuration

- 1) Visit www.maxim-ic.com/evkitsoftware to download the latest version of the EV kit software, 5960LRxx.ZIP. Save the EV kit software to a temporary folder and uncompress the ZIP file.
- 2) Install the EV kit software on your computer by running the INSTALL.EXE program inside the temporary folder. The program files are copied and icons are created in the Windows **Start | Programs** menu.
- 3) Verify that no shunts are installed on jumpers JU1, JU2, JU3, and JU4 (PRES-DET_).
- 4) Verify that shunts are installed on pins 2 and 3 of jumpers JU5, JU6, JU7, JU8, JU11, JU12, JU13, and JU14 (computer control).
- 5) Verify that a shunt is not installed on jumpers JU9, JU10, JU15, and JU16 (MRL_).
- 6) Utilizing short 25A-rated banana leads (< 12in long) connect the 12V DC power supply to the VIN1 banana jack. Utilizing short 25A-rated banana leads (< 12in long) connect the supply ground to the GND banana jack.
- 7) Utilizing short 25A-rated banana leads (< 12in long) connect the 3.3V DC power supply to the VIN2 banana jack. Utilizing short 25A-rated banana leads (< 12in long) connect the supply ground to the GND banana jack.
- 8) Connect the 3.3V DC power supply to the VIN3 banana jack with a short banana lead. Do not turn on the power supplies.

MAX5960L Evaluation Kit/ Evaluation System

- 9) Connect a voltmeter to the 12VA pad and GND. Connect a voltmeter to the 3.3VA pad and GND. Connect a voltmeter to the 3.3VAUXA pad and GND.
- 10) Connect the CMAXQUSB interface board to the MAX5960L EV kit's J9 connector.
- 11) Set both CMAXQUSB interface board SW1 switches to enable. These provide pullup resistors for the SDA and SCL 2-wire bus signals.
- 12) Turn on the 12V and 3.3V power supplies for the EV kit. The CMAXQUSB interface board is powered through the computer's USB port.
- 13) Connect the USB cable from the PC to the CMAXQUSB board. A **Building Driver Database** window should pop up in addition to a **New Hardware Found** message if this is the first time the EV kit board is connected to the PC. If you do not see a window that is similar to the one described above after 30s, try removing the USB cable from the CMAXQUSB interface board and reconnect it. Administrator privileges are required to install the USB device driver on Windows 2000 and XP. Refer to the document TROUBLESHOOTING_USB.PDF included with the software if you have any problems during this step.
- 14) Follow the directions of the **Add New Hardware Wizard** to install the USB device driver. Choose the **Search for the best driver for your device** option. Specify the location of the device driver to be **C:\Program Files\MAX5960L** (default installation directory) using the **Browse** button.
- 15) Start the MAX5960L program by opening its icon in the **Start | Programs** menu.
- 16) The software will detect the CMAXQUSB interface board, the SMBus address of ICs U2, U3, U4, and will also be updated on the status screen. The software is then ready for changes in the command section.
- 17) Install a shunt on jumper JU3 ($\overline{\text{PRES-DETA}}$) or insert a PCI Express card into channel A PCI Express connector J1.
- 18) To evaluate channels B, C, and D, use analogous actions on step 17 above for the respective channel. See the *Jumper and Switch Selection* section for more information on configuring each channel.

See the *Detailed Description of Software* section for more information on the software GUI features. See the *MAX7313 Input/Output Expanders and SMBus Interface* section for configuring the input/output expander, using the CMAXQUSB interface board.

Detailed Description

The MAX5960L EV kit demonstrates a PCI Express x16 quad hot-plug circuit design. Four PCI Express x16 channels (A, B, C, and D) are provided to evaluate PCI Express x16 line cards. The EV kit uses a latching MAX5960L hot-plug controller in an 80-pin TQFP package to control all four channels' output power and monitor for faults.

The MAX5960L IC controls each channel's output power independently. External n-channel MOSFETs are used to control power to the 12V and 3.3V outputs of each channel. Current-sensing resistors R32, R47, R34, and R48 are used for the 12V, and resistors R39, R53, R40, and R54 for the 3.3V outputs of the respective channel. Internal MOSFETs on the MAX5960L control the 3.3V auxiliary outputs of each channel.

If an overcurrent fault persists on either channel, the MAX5960L will shut down the respective channel. The fault is reported at the respective channels' open-drain power-good pin ($\overline{\text{PWRGD}}$) and fault pin ($\overline{\text{FAULT}}$). The MAX5960L power-on reset (POR) is configured for 160ms; however, the POR can be reconfigured after installing resistor R18.

Slide switches are provided to enable/disable each channel's main output and auxiliary output independently when the SMBus control is not used. Jumpers JU1–JU4 can be used to provide a presence-detect function for the respective channel if PCI Express cards are not used. Momentary pushbutton switches SW1–SW4 are provided to demonstrate the MAX5960L debounced logic gate outputs.

The MAX5960L EV kit features green LEDs connected to each channel's 12V, 3.3V, and 3.3V auxiliary output that indicate if the respective output is currently powered. Red test points for the 12V and 3.3V outputs, various PCI Express signals, and other circuit signals such as the gate drive of each MOSFET have been provided for probing on the EV kit board. All the EV kit's black test points are GND points.

The EV kit also features PCB pads for installing external resistors and capacitors near each MOSFET gate terminal to increase the MOSFET's gate-turn-on time. Surface-mount 0805 case-size components can be installed at these locations. See Figure 4 for each of the MOSFET's gate R and C designators.

The EV kit can be reconfigured for evaluating a x1, x4, or x8 PCI Express quad hot-plug design by replacing the appropriate current-sense resistor, R32, R34, R47, or R48. Consult the appropriate *PCI Express* specification in the MAX5960L IC data sheet for selecting other designs. PCB pads are provided to demonstrate the MAX5960L hot-plug features without using the PCI Express x16 connectors.

MAX5960L Evaluation Kit/ Evaluation System

For evaluating external DC loads, the cables connecting the 12V and 3.3V outputs to the external DC load must be rated for at least 10A and be shorter than 12in. Additionally, all current-sense resistors are configured for the maximum allowable output current on the 12V and 3.3V outputs. These resistors should be reconfigured only for lower output currents.

The MAX5960L EV kit features three MAX7313 16-port I/O expanders (U2, U3, U4) and PCB pads for interfacing to a user's SMBus system. Resistors configure each MAX7313 to a fixed SMBus serial address. The address of U2 is 0x40, U3 is 0x42, and U4 is 0x44. The MAX7313 can also be used to enable/disable each channel's main output and auxiliary output independently. See the *MAX7313 Input/Output Expanders and SMBus Interface* section for more details.

Jumper and Switch Selection

The jumper and switch selections in the following tables display the functions provided by the MAX5960L EV kit.

Presence-Detect Channels A, B, C, and D

The MAX5960L EV kit features four jumpers that can simulate a PCI Express x16 card being plugged into a connector. Jumpers JU1, JU2, JU3, and/or JU4 are used to provide a presence-detect function for the respective channel. An external load (resistive and capacitive) must be connected to the channel's output PCB pads simulating a real PCI Express card. Table 1 lists the various jumper options.

Channel A Enable/Disable Switches

The MAX5960L EV kit features two switches to enable/disable the 12V/3.3V main and 3.3V auxiliary channel A outputs. The switches can also be used to reset a channel that has latched off after a fault has occurred. Table 2 lists the various switch options.

Channel B Enable/Disable Switches

The MAX5960L EV kit features two switches to enable/disable the 12V/3.3V main and 3.3V auxiliary channel B outputs. The switches can also be used to reset a channel that has latched off after a fault has occurred. Table 3 lists the various switch options.

Table 1. Channel A, B, C, and D Presence-Detection Functions

JUMPER	SHUNT	MAX5960L PIN CONNECTION	EV KIT OPERATION SIMULATED
JU3	Installed	PRES-DETA pin pulled low	PCI Express card inserted in channel A
	None*	PRES-DETA pin pulled high	No PCI Express card in channel A
JU4	Installed	PRES-DETB pin pulled Low	PCI Express card inserted in channel B
	None*	PRES-DETB pin pulled high	No PCI Express card in channel B
JU2	Installed	PRES-DETC pin pulled low	PCI Express card inserted in channel C
	None*	PRES-DETC pin pulled high	No PCI Express card in channel C
JU1	Installed	PRES-DETD pin pulled low	PCI Express card inserted in channel D
	None*	PRES-DETD pin pulled high	No PCI Express card in channel D

*When using a real PCI Express card, these jumper shunts must be removed so that the card has control of the presence detection.

Table 2. Channel A Switch Functions

SWITCH	SWITCH STATE	MAX5960L PIN CONNECTION	MAX5960L OPERATION
SW5	ON	ONA pin pulled high	Enable channel A main outputs
	OFF	ONA pin pulled low	Disable channel A main outputs
SW6	ON	AUXONA pin pulled high	Enable channel A 3.3V auxiliary output
	OFF	AUXONA pin pulled low	Disable channel A 3.3V auxiliary output

MAX5960L Evaluation Kit/ Evaluation System

Channel C Enable/Disable Switches

The MAX5960L EV kit features two switches to enable/disable the 12V/3.3V main and 3.3V auxiliary channel C outputs. The switches can also be used to reset a channel that has latched off after a fault has occurred. Table 4 lists the various switch options.

Channel D Enable/Disable Switches

The MAX5960L EV kit features two switches to enable/disable the 12V/3.3V main and 3.3V auxiliary channel D outputs. The switches can also be used to reset a channel that has latched off after a fault has occurred. Table 5 lists the various switch options.

Control Methods, Other Configurations, and I/O Expander

Fault Resetting

The MAX5960L EV kit features slide switches to reset a latched fault at each channel. The switch resets the respective EV kit channel and unlatches the fault when toggled from ON to OFF. See Tables 2 through 5 for resetting the respective channel. Refer to the MAX5960L IC data sheet for additional functions of the MAX5960L ON_ pins.

Fault Timeout and POR Periods

The MAX5960L fault timeout period is configured for 10ms and can be reconfigured to a new timeout period by installing surface-mount resistor R17. The MAX5960L POR timeout period is configured for 160ms; however, a new POR timeout period can be reconfigured by installing surface-mount resistor R18. Install a 0Ω resistor at R18 to bypass the POR time period delay. Refer to MAX5960L IC data sheet *Power-Good (PWRGD_)* section for selecting the values of resistors R17 or R18.

Table 3. Channel B Switch Functions

SWITCH	SWITCH STATE	MAX5960L PIN CONNECTION	MAX5960L OPERATION
SW7	ON	ONB pin pulled high	Enable channel B main outputs
	OFF	ONB pin pulled low	Disable channel B main outputs
SW8	ON	AUXONB pin pulled high	Enable channel B 3.3V auxiliary output
	OFF	AUXONB pin pulled low	Disable channel B 3.3V auxiliary output

Table 4. Channel C Switch Functions

SWITCH	SWITCH STATE	MAX5960L PIN CONNECTION	MAX5960L OPERATION
SW9	ON	ONC pin pulled high	Enable channel C main outputs
	OFF	ONC pin pulled low	Disable channel C main outputs
SW10	ON	AUXONC pin pulled high	Enable channel C 3.3V auxiliary output
	OFF	AUXONC pin pulled low	Disable channel C 3.3V auxiliary output

Table 5. Channel D Switch Functions

SWITCH	SWITCH STATE	MAX5960L PIN CONNECTION	MAX5960L OPERATION
SW11	ON	OND pin pulled high	Enable channel D main outputs
	OFF	OND pin pulled low	Disable channel D main outputs
SW12	ON	AUXOND pin pulled high	Enable channel D 3.3V auxiliary output
	OFF	AUXOND pin pulled low	Disable channel D 3.3V auxiliary output

Evaluate: MAX5959A/MAX5959L/MAX5960A/MAX5960L

MAX5960L Evaluation Kit/ Evaluation System

Forced ON Inputs

Either channel PCI Express slot can be forced to turn on regardless of the MAX5960L logic status inputs. To force channel A on, install surface-mount resistor R9 or install the respective channel's resistor. Typical values are less than 1k Ω . Additionally, the MAX5960L EV kit software can be used to force a channel on without installing the resistor. See the *Software Startup* section for more information.

Current Limiting

The MAX5960L EV kit is configured for PCI Express x16 current limits. The EV kit can also evaluate other current-limit configurations for the 12V and 3.3V main outputs of each channel. Resistors R32, R47, R34, and R48 set the 12V current-limit for channels A, B, C, and D, respectively. Resistors R39, R53, R40, and R54 set the 3.3V current limit for channels A, B, C, and D, respectively. These resistors should be reconfigured only for lower output currents. Refer to the MAX5960L IC data sheet for information on selecting other current-limit resistors.

The 3.3V auxiliary current limit is fixed at 700mA (typ) and is not reconfigurable. However, a MAX5959L can be installed to evaluate an auxiliary current limit of 470mA (typ) with the EV kit.

Evaluating Other Quad PCI Express Hot-Plug Controllers

The MAX5960L EV kit can be used to evaluate the MAX5959A, MAX5959L, or MAX5960A. Replace U1 with the desired Maxim IC that can be ordered through the factory.

MAX7313 Input/Output Expanders and SMBus Interface

The MAX5960L EV kit features three MAX7313 I/O expanders (U2, U3, U4) and PCB pads for connecting to an SMBus system (SDA and SCL signals). The I/O expander interfaces with the PRES-DET_, FAULT_, ON_, OUT_, PWRGD_, and FON_ signals of the MAX5960L for each channel. Headers J5–J8 (8 pins) are provided to enable easy access to the respective channel's signals through a ribbon cable or scope probe. Green and yellow LEDs (D14–D21) are also provided for user applications such as status indication. Jumpers JU9, JU10, JU15, and JU16 are provided to mimic a PCI Express mechanical retention locking (MRL) signal for the respective channel. Resistors configure each MAX7313 to a fixed SMBus serial address, where U2 is 0x40, U3 is 0x42, and U4 is 0x44.

If the MAX7313 I/O expander is used to control the ON_ signals and read back various other MAX5960L signals of each channel, jumpers JU5–JU14 must be properly configured or the I/O expanders may be destroyed when switching logic states. See Table 6 for configuring jumpers JU5–JU14. Pads are provided on the EV kit's PCB for interfacing with a user's system SMBus VDD, SDA, SCL, and GND signals.

If a user's SMBus system is not available, a Windows-based computer can be interfaced with the EV kit by connecting the CMAXQUSB interface board to connector J9. The interface board enables the computer to interface with the EV kit's SMBus signals. The SMBus interface board and software provides the user with an option of using a Windows-based GUI interface or "bit-banging" signals to and from the MAX7313 I/O expander's various registers to control the MAX5960L IC.

MAX5960L Evaluation Kit/ Evaluation System

Table 6. MAX5960L Channels A, B, C, and D ON_ Signals Configuration

JUMPER	SHUNT LOCATION	MAX5960L PIN CONNECTION	EV KIT OPERATION
JU5	1 and 2	AUXONA controlled by SW6	Local switch control
JU6	1 and 2	ONA controlled by SW5	Local switch control
JU7	1 and 2	ONB controlled by SW7	Local switch control
JU8	1 and 2	AUXONB controlled by SW8	Local switch control
JU11	1 and 2	AUXONC controlled by SW9	Local switch control
JU12	1 and 2	ONC controlled by SW10	Local switch control
JU13	1 and 2	OND controlled by SW11	Local switch control
JU14	1 and 2	AUXOND controlled by SW12	Local switch control
JU5	2 and 3	AUXONA controlled by U2, MAX7313 with SMBus	SMBus or computer control
JU6	2 and 3	ONA controlled by U2, MAX7313 with SMBus	SMBus or computer control
JU7	2 and 3	ONB controlled by U2, MAX7313 with SMBus	SMBus or computer control
JU8	2 and 3	AUXONB controlled by U2, MAX7313 with SMBus	SMBus or computer control
JU11	2 and 3	AUXONC controlled by U3, MAX7313 with SMBus	SMBus or computer control
JU12	2 and 3	ONC controlled by U3, MAX7313 with SMBus	SMBus or computer control
JU13	2 and 3	OND controlled by U3, MAX7313 with SMBus	SMBus or computer control
JU14	2 and 3	AUXOND controlled by U3, MAX7313 with SMBus	SMBus or computer control

Evaluate: MAX5959A/MAX5959L/MAX5960A/MAX5960L

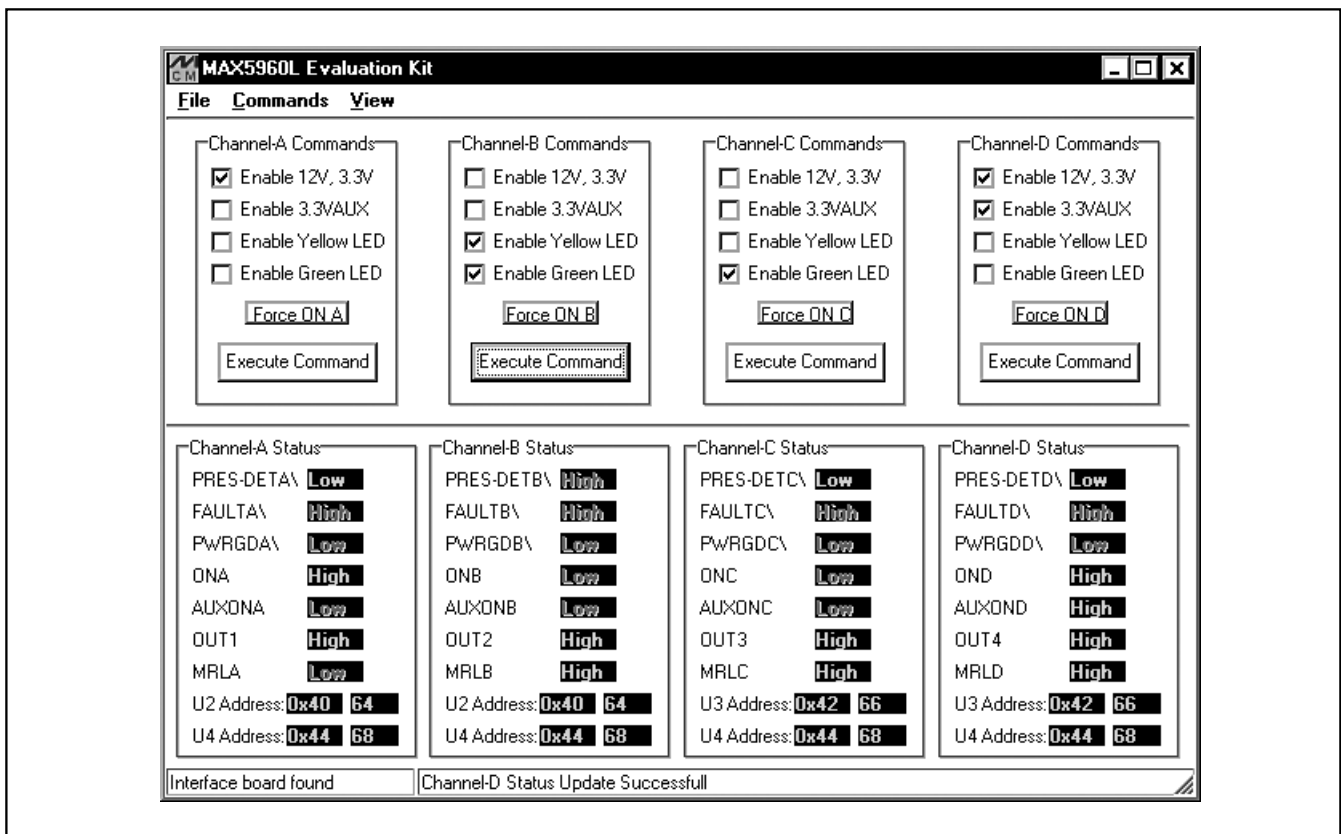

Figure 1. The MAX5960L Evaluation Software Main Window for Reading Current EV Kit Status and Sending Commands

MAX5960L Evaluation Kit/ Evaluation System

Detailed Description of Software

A mouse or the keyboard's Tab key is used to navigate various items on the Main Window. Most of the main window's available functions and a few more can be evaluated by using the pulldown menu. The software features a demo mode that is available using the **ViewDemo Mode** pulldown menu.

Software Startup

Upon starting the program, the MAX5960L EV kit software automatically detects U2, U3, and U4 addresses and configures their I/O. See Tables 7 and 8 for U2, U3, and U4 configuration by the software. The MAX5960L EV kit's various status signals are then updated by the program approximately every 500ms. Use the checkboxes to enable/disable various EV kit functions and then select the **Execute Command** button to send the commands to the respective I/O expander and/or U1. Deselecting a checkbox disables the command.

To force a respective channel ON, select the respective channel's latching **FORCE ON** button. To turn OFF a forced ON channel, select the button again. When a respective channel is forced ON, that particular channel's controls are disabled until force ON is turned off.

The software's **Status** area provides information on the various MAX5960L and PCI Express system signal's condition. Each MAX7313 I/O expander SMBus address is provided in hexadecimal and decimal format, respectively. The left bottom status bar of the main

window provides the CMAXQUSB interface board communication status. The right bottom status bar provides the current program status and SMBus communication status with respect to the respective I/O expander.

The MAX5960L EV kit software configures the CMAXQUSB interface board's SMBus communication speed to 400kHz by default. The speed can be reduced to 100kHz if required, by selecting the pulldown menu's **View2-Wire Speed100kHz** selection. This may be required if slower SMBus or 2-wire devices are connected to the bus on the EV kit.

General-Purpose 2-Wire Interface Utility

The general-purpose 2-wire interface utility can also be used to communicate with the MAX7313 and thus control or read back signals from the MAX7313 and/or MAX5960L. Use the **ViewInterface** pulldown menu to access the utility. The utility configures the SMBus interface parameters such as start and stop bits, acknowledgments, and clock timing. The 2-wire interface screen allows you to send general-purpose SMBus commands using the **SMBusWriteByte** and **SMBusReadByte**. The interface utility only accepts and outputs hexadecimal number format.

The **Hunt for active listeners** button scans the entire 2-wire address space, reporting each address that is acknowledged. The **SMBusWriteByte** transmits the device address, command, and 1 byte of data. The **SMBusReadByte** transmits the device address, a command, and then retransmits the device address and reads 1 byte of data.

Table 7. MAX7313 I/O Port Configuration/Function for U2 and U3

MAX7313 PORT I/O	PORT P7 (BIT D7)	PORT P6 (BIT D6)	PORT P5 (BIT D5)	PORT P4 (BIT D4)	PORT P3 (BIT D3)	PORT P2 (BIT D2)	PORT P1 (BIT D1)	PORT P0 (BIT D0)
PORT CONFIG	OUTPUT	OUTPUT	INPUT	INPUT	OUTPUT	OUTPUT	INPUT	INPUT
EV KIT FUNCTION	YELLOW LED	GREEN LED	PRES-DET	FAULT	AUXON	ON	OUT	MRL

Table 8. MAX7313 I/O Port Configuration/Function for U4

MAX7313 PORT I/O	PORT P7 (BIT D7)	PORT P6 (BIT D6)	PORT P5 (BIT D5)	PORT P4 (BIT D4)	PORT P3 (BIT D3)	PORT P2 (BIT D2)	PORT P1 (BIT D1)	PORT P0 (BIT D0)
PORT CONFIG	OUTPUT	OUTPUT	OUTPUT	OUTPUT	INPUT	INPUT	INPUT	INPUT
EV KIT FUNCTION	FOND	FONC	FONB	FONA	PWRGDD	PWRGDC	PWRGDB	PWRGDA

MAX5960L Evaluation Kit/ Evaluation System

For information on the differences between a 2-wire and an SMBus interface, read Application Note: *Comparing the I²C Bus to the SMBus* at www.maxim-ic.com.

General Troubleshooting

Problem: Software reports it cannot find the interface board.

- Is the interface board power LED lit?
- Is the USB communications cable connected?
- Has Windows plug-and-play detected the board? Bring up **Control Panel->System->Device Manager**, and look at what device nodes are indicated for USB. If there is an “unknown device” node attached to the USB, delete it—this forces plug-and-play to try again.

Problem: Unable to find U2, U3, or U4 (MAX7313).

- Is power applied to the MAX5960L EV kit VIN2 and VIN3 banana jacks? This is required for powering U2, U3, and U4.
- Are the SCL and SDA signals pulled up to VDD? The CMAXQUSB interface board dip switch SW1 enables the on-board resistors on the interface board. There must be pullup resistors somewhere for the SMBus SCL and SDA signals.
- If using jumper wires to connect, are the SCL and SDA signals swapped? Is the ground return missing?

Evaluate: MAX5959A/MAX5959L/MAX5960A/MAX5960L

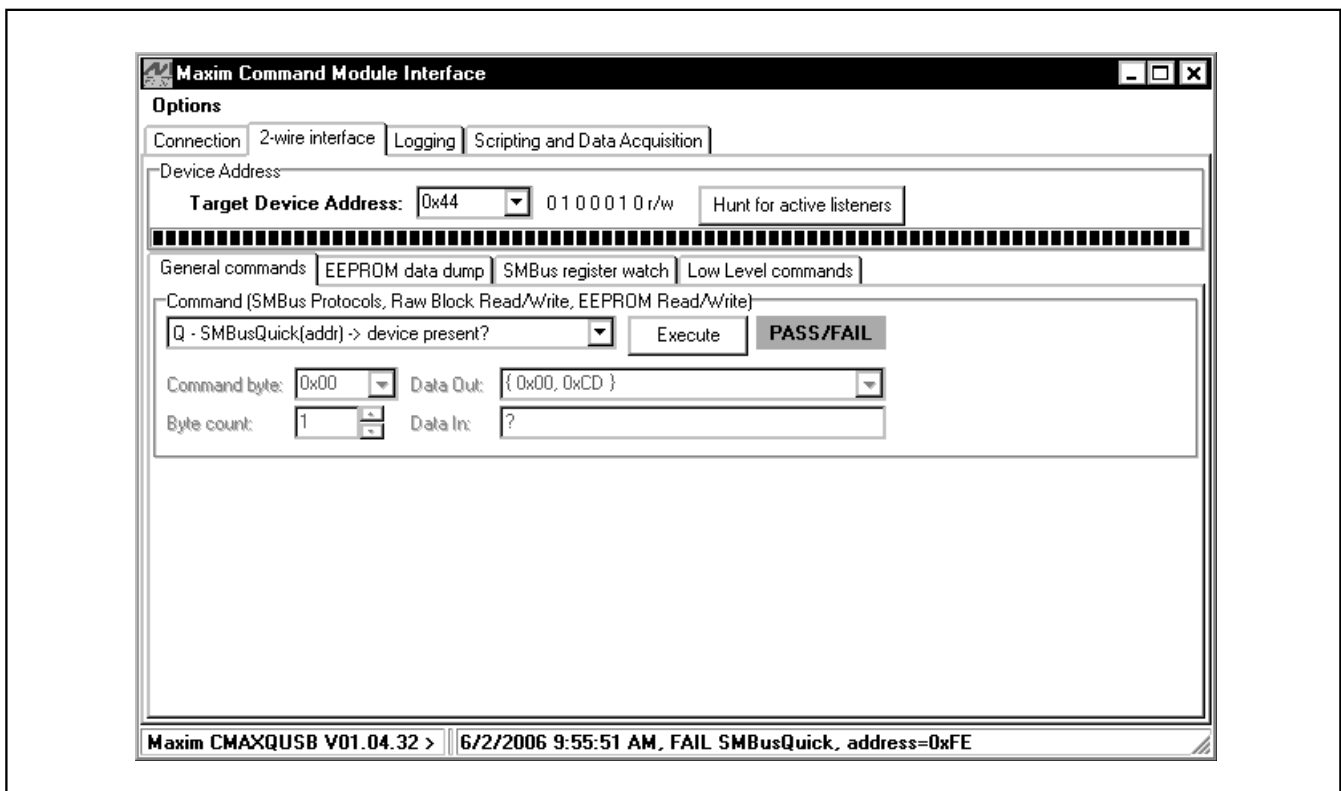

Figure 2. The 2-Wire Interface Window Provides Direct, Low-Level Access to the MAX5960L with the MAX7313 and SMBus 2-Wire Interface

MAX5960L Evaluation Kit/ Evaluation System

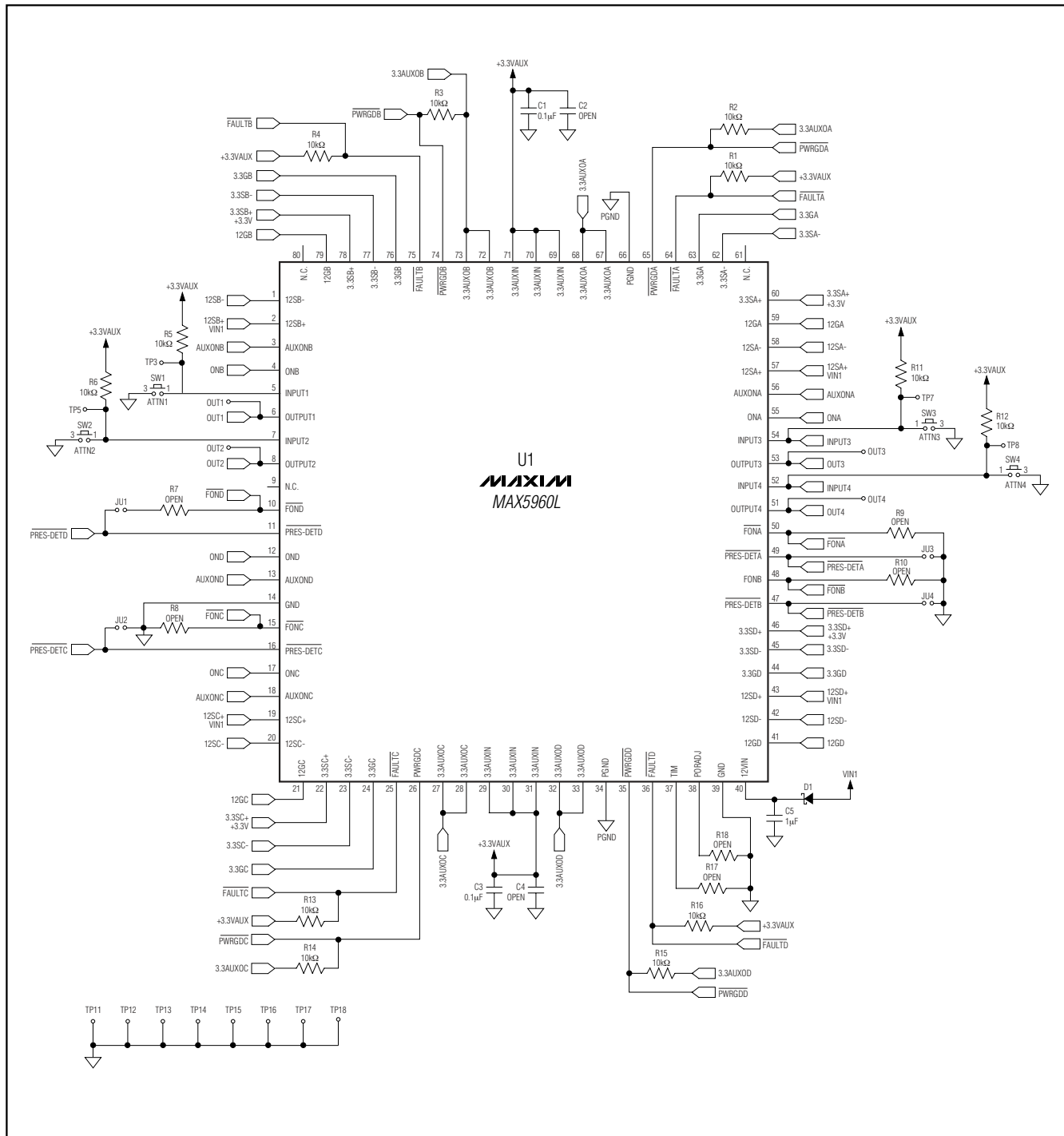

Figure 3. MAX5960L EV Kit Schematic, Quad PCI Express Controller

MAX5960L Evaluation Kit/ Evaluation System

Evaluate: MAX5959A/MAX5959L/MAX5960A/MAX5960L

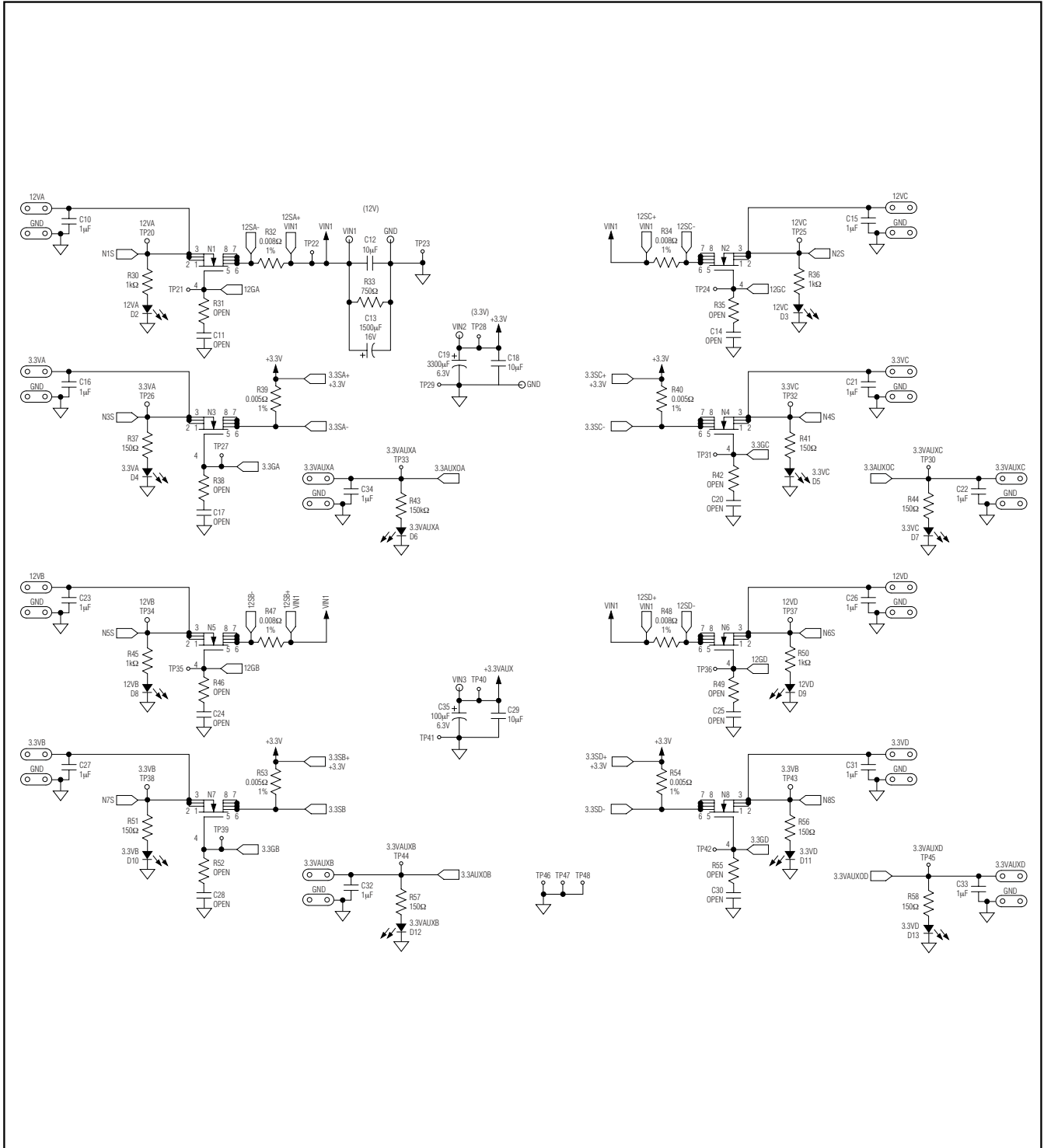

Figure 4. MAX5960L EV Kit Schematic, Quad PCI Express Hot Swap

MAX5960L Evaluation Kit/ Evaluation System

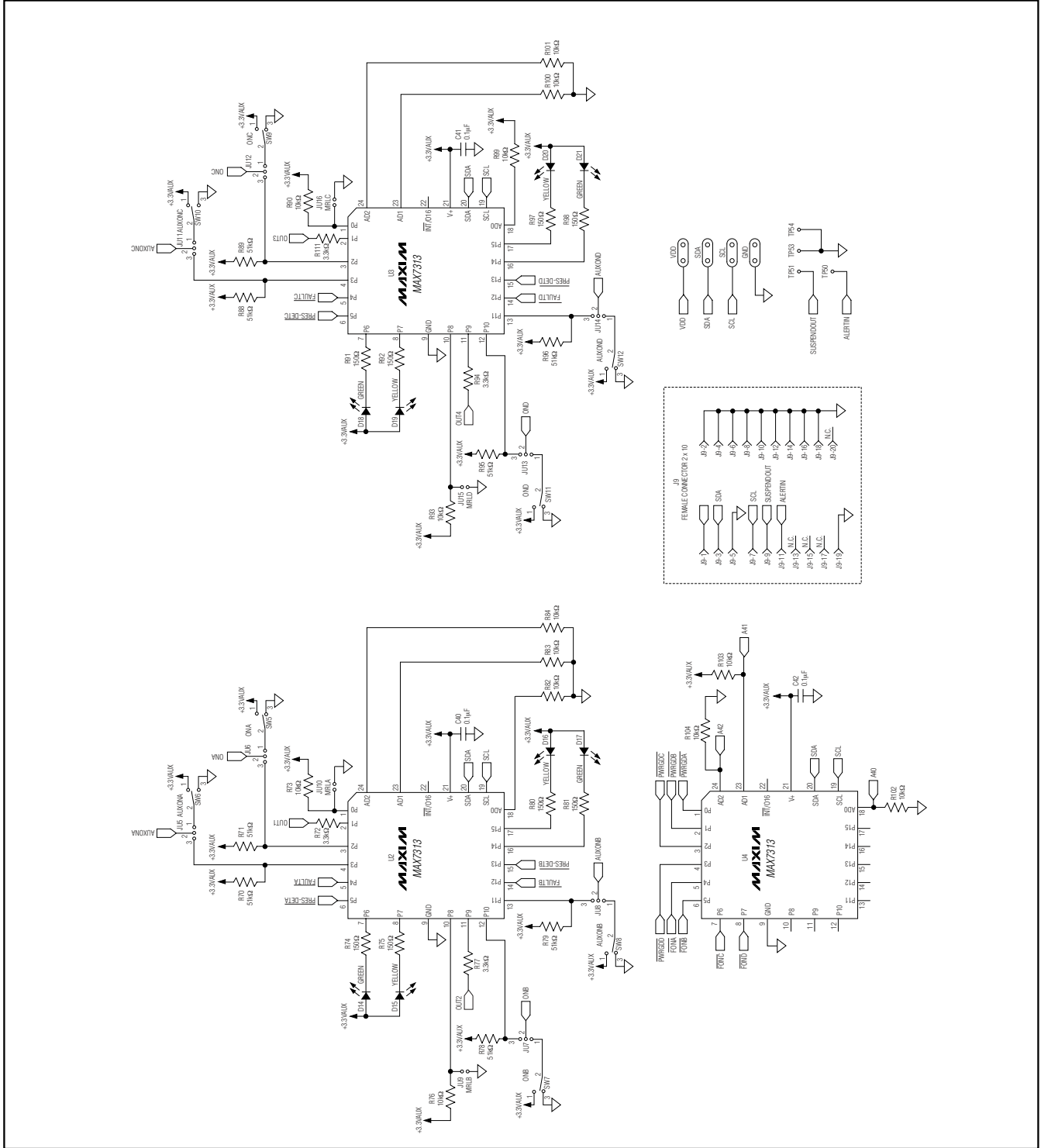

Figure 5. MAX5960L EV Kit Schematic, SMBus I/O Control

MAX5960L Evaluation Kit/ Evaluation System

Evaluate: MAX5959A/MAX5959L/MAX5960A/MAX5960L

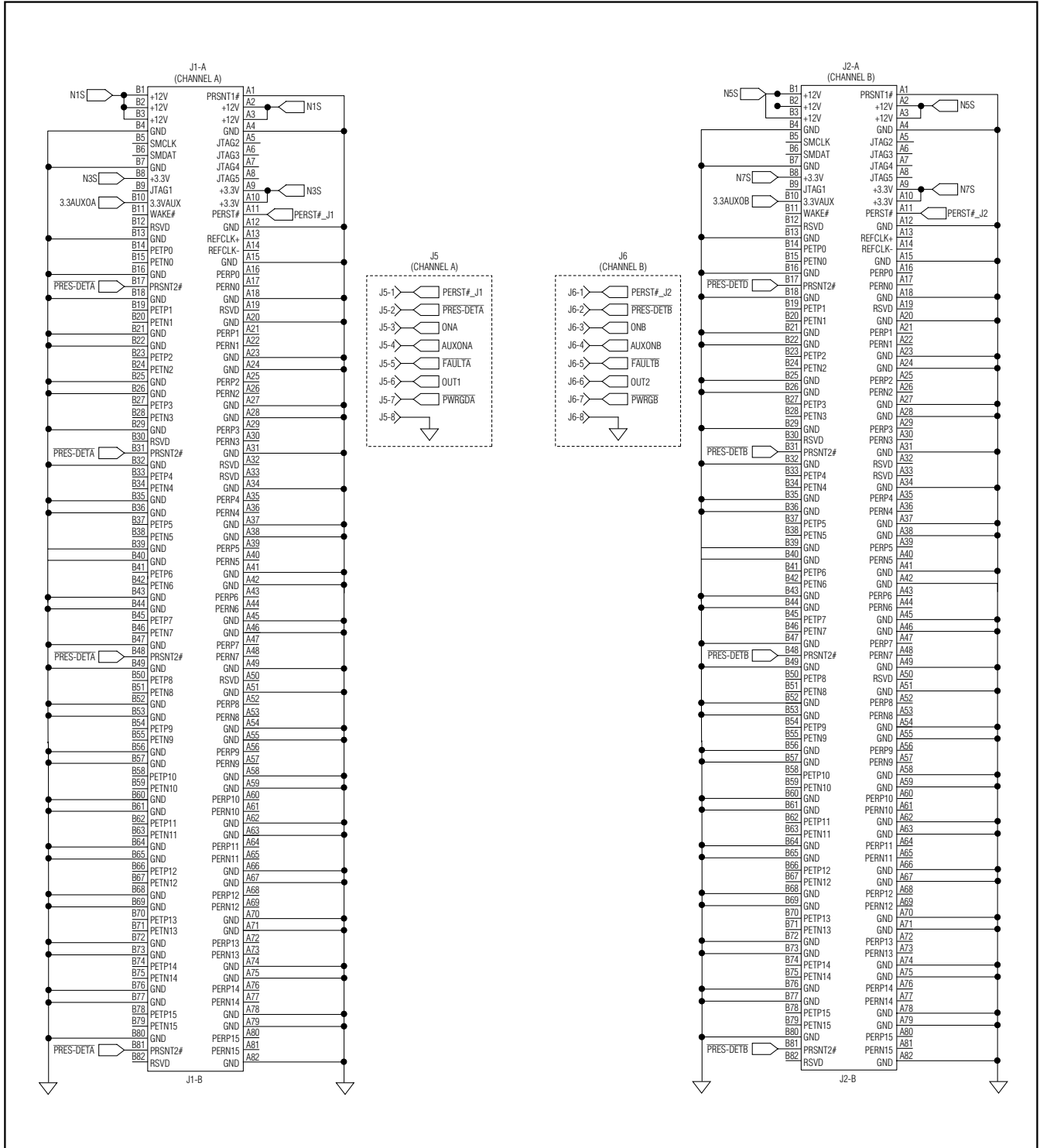

Figure 6. MAX5960L EV Kit Schematic, PCI Express x16 Channels A and B

MAX5960L Evaluation Kit/ Evaluation System

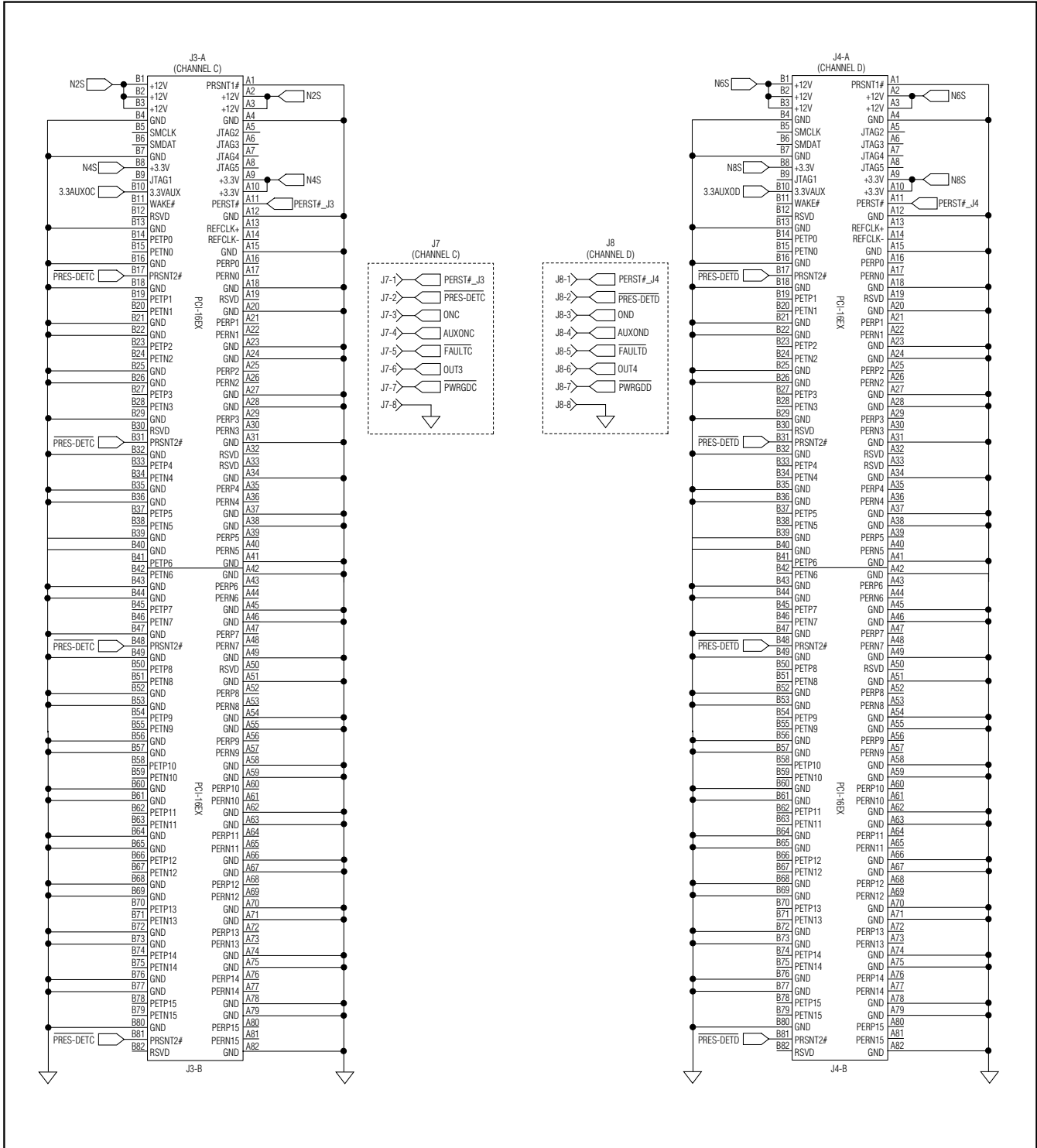

Figure 7. MAX5960L EV Kit Schematic, PCI Express x16 Channels C and D

MAX5960L Evaluation Kit/ Evaluation System

Evaluate: MAX5959A/MAX5959L/MAX5960A/MAX5960L

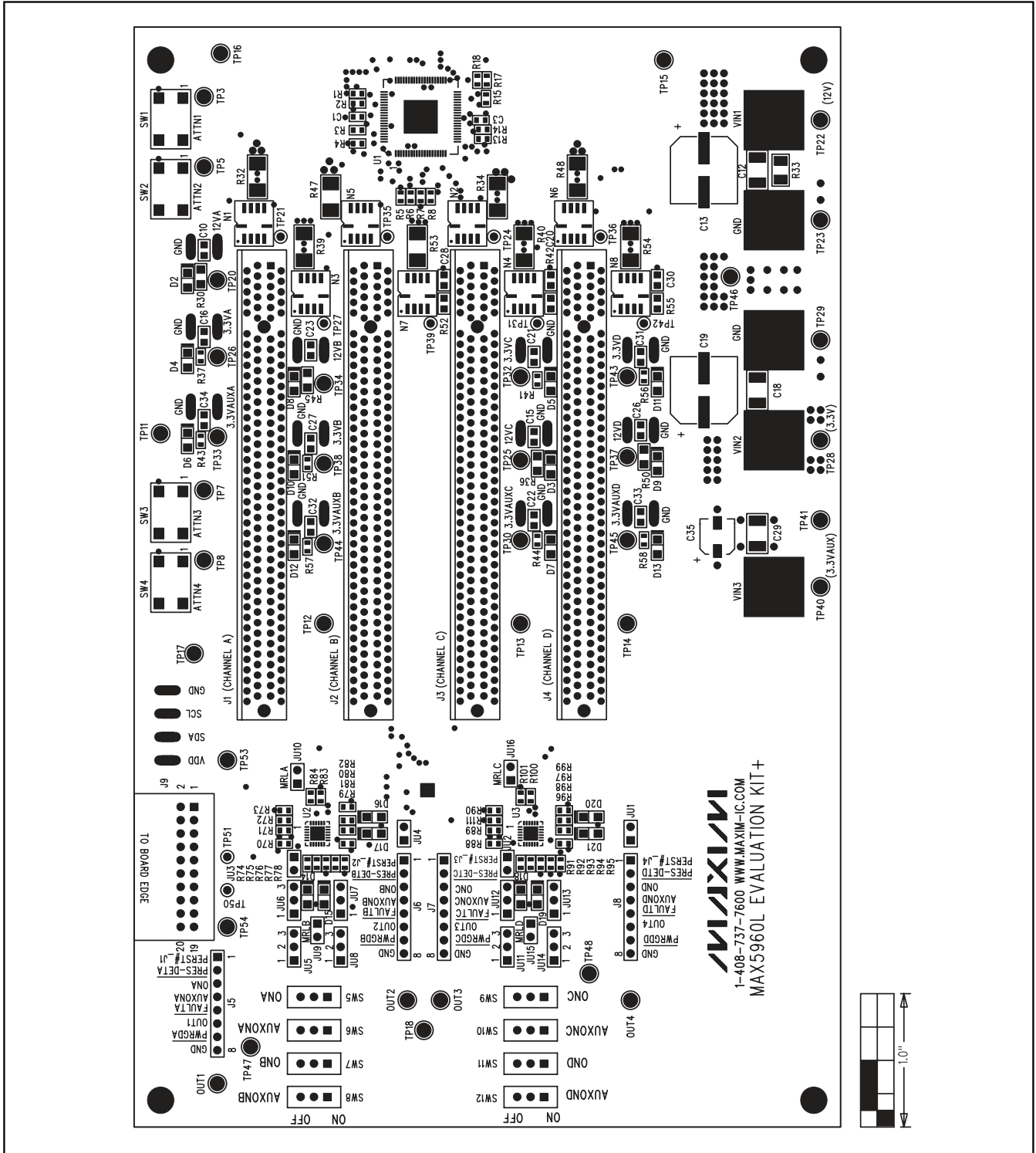

Figure 8. MAX5960L EV Kit Component Placement Guide—Component Side

MAX5960L Evaluation Kit/ Evaluation System

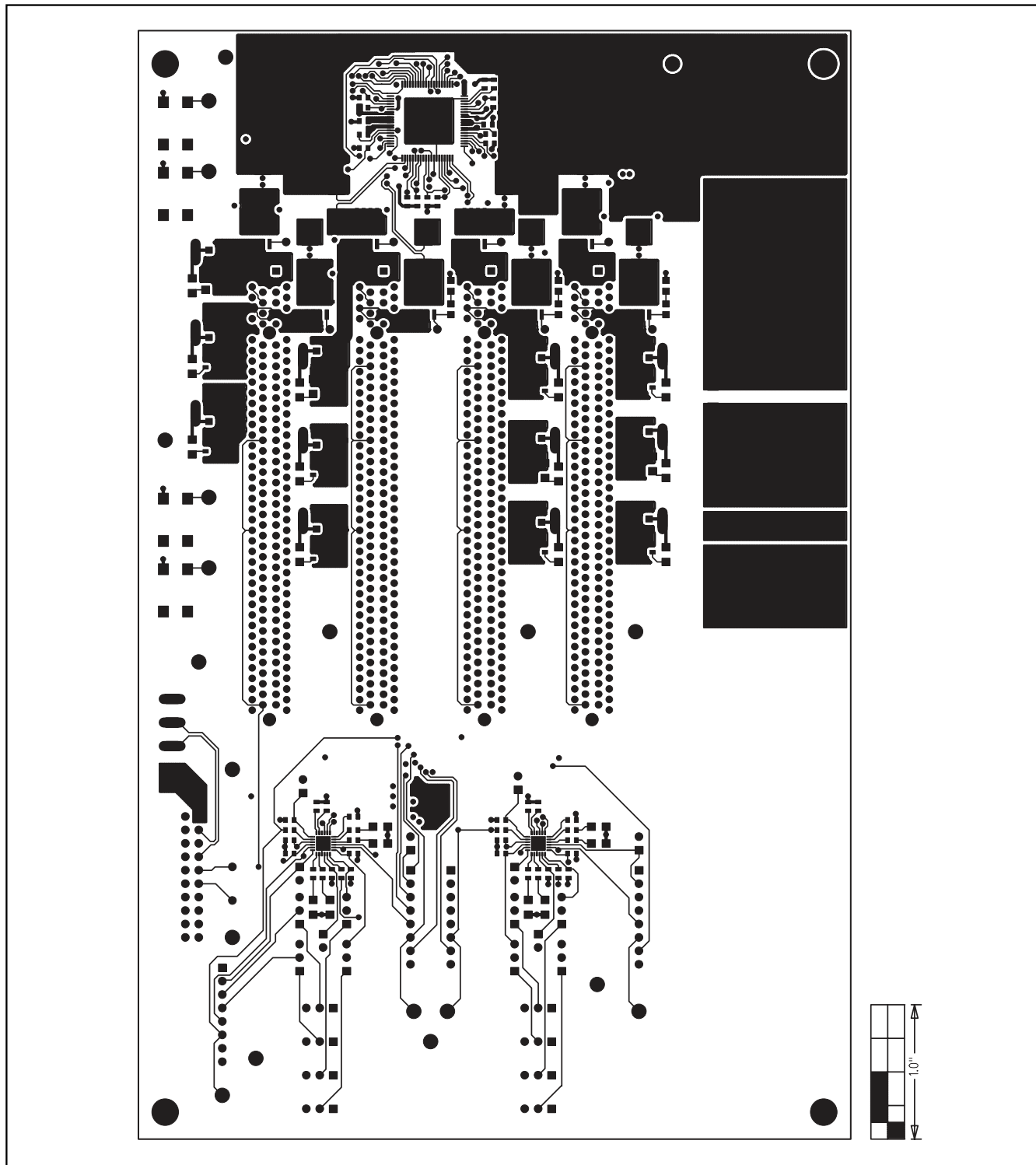

Figure 9. MAX5960L EV Kit PCB Layout—Component Side

MAX5960L Evaluation Kit/ Evaluation System

Evaluate: MAX5959A/MAX5959L/MAX5960A/MAX5960L

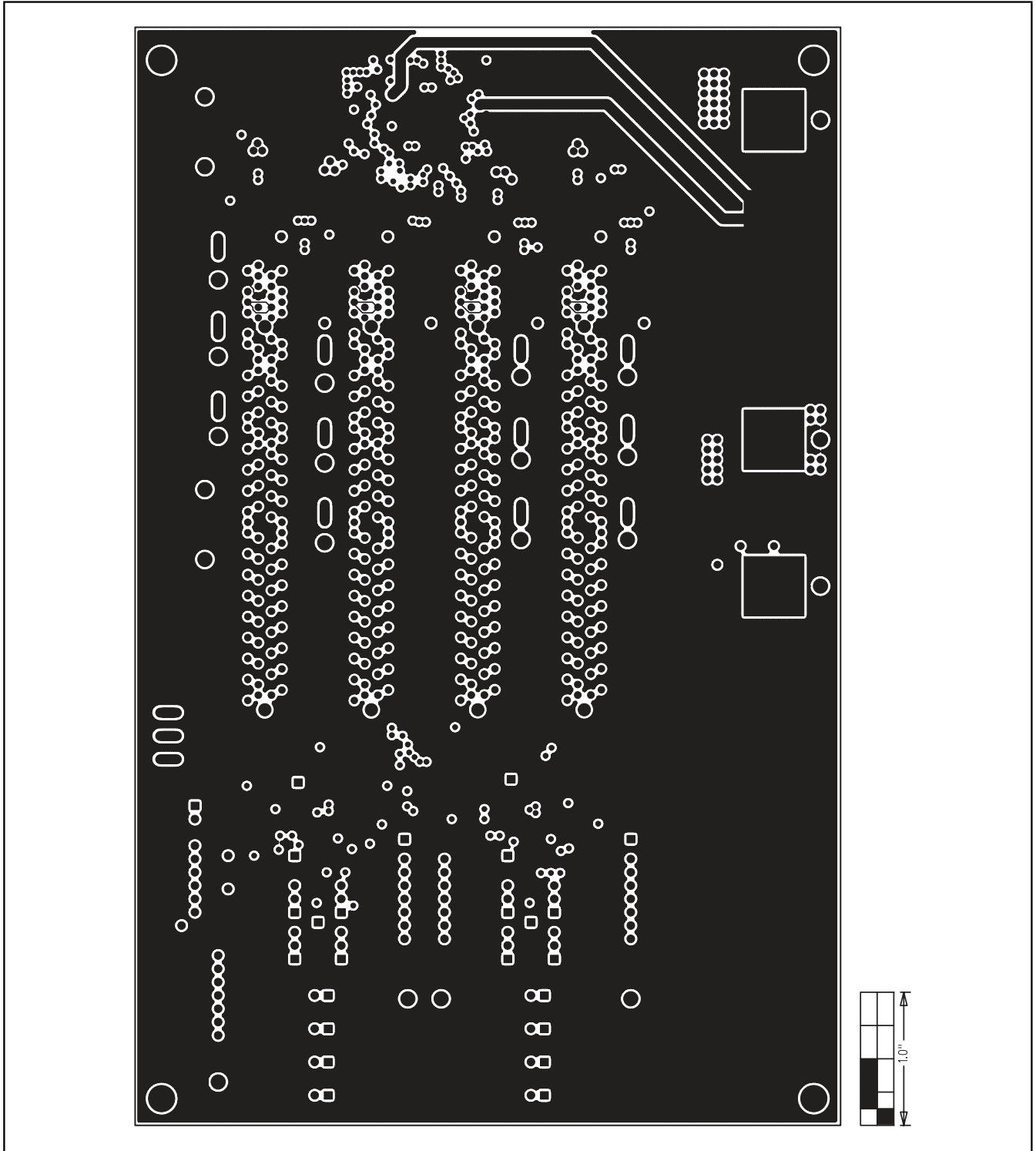

Figure 10. MAX5960L EV Kit PCB Layout—Inner Layer, Ground Plane Layer 2

MAX5960L Evaluation Kit/ Evaluation System

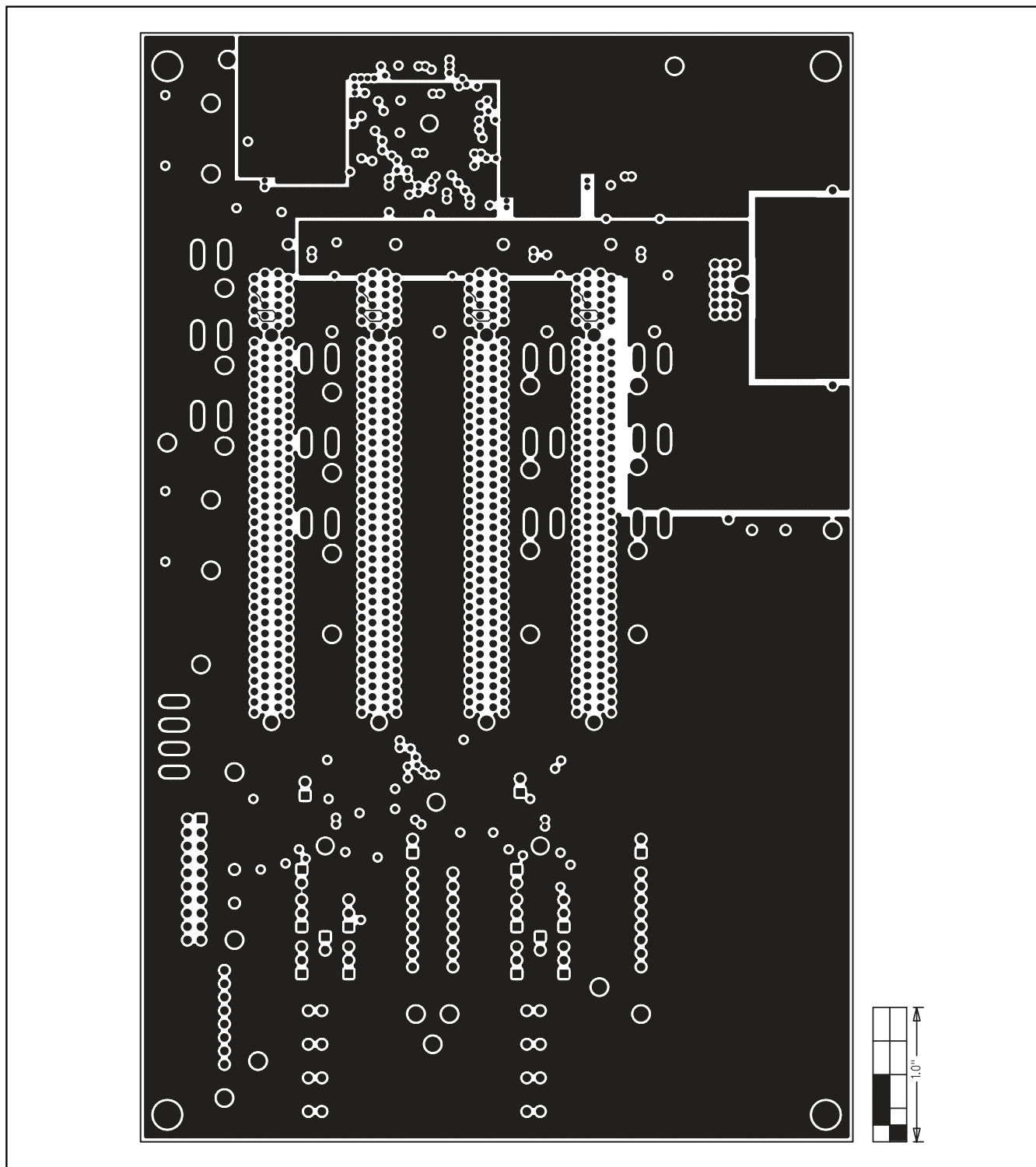

Figure 11. MAX5960L EV Kit PCB Layout—Inner Layer, Power Plane Layer 3

MAX5960L Evaluation Kit/ Evaluation System

Evaluate: MAX5959A/MAX5959L/MAX5960A/MAX5960L

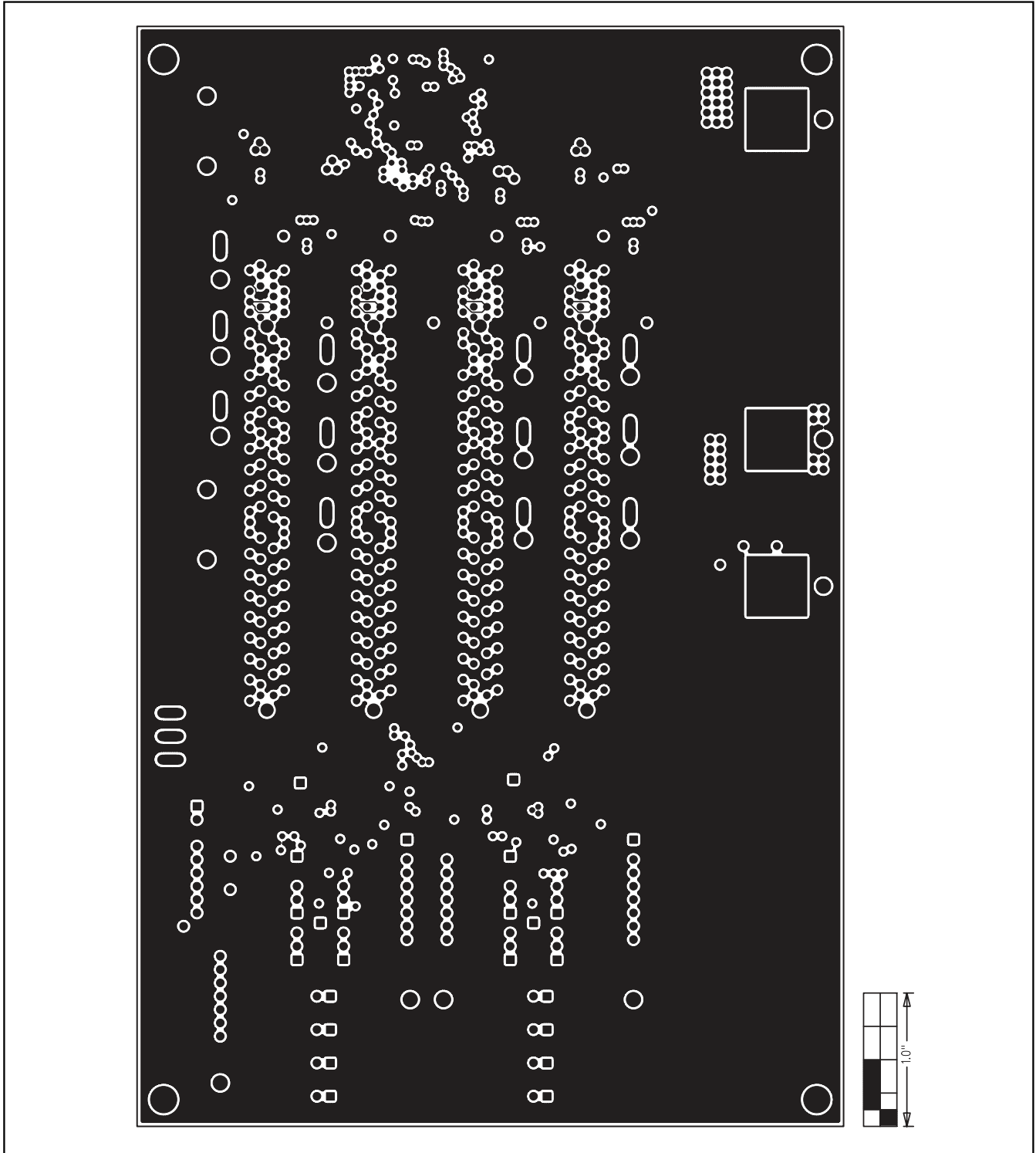

Figure 12. MAX5960L EV Kit PCB Layout—Inner Layer, Ground Plane Layer 4

MAX5960L Evaluation Kit/ Evaluation System

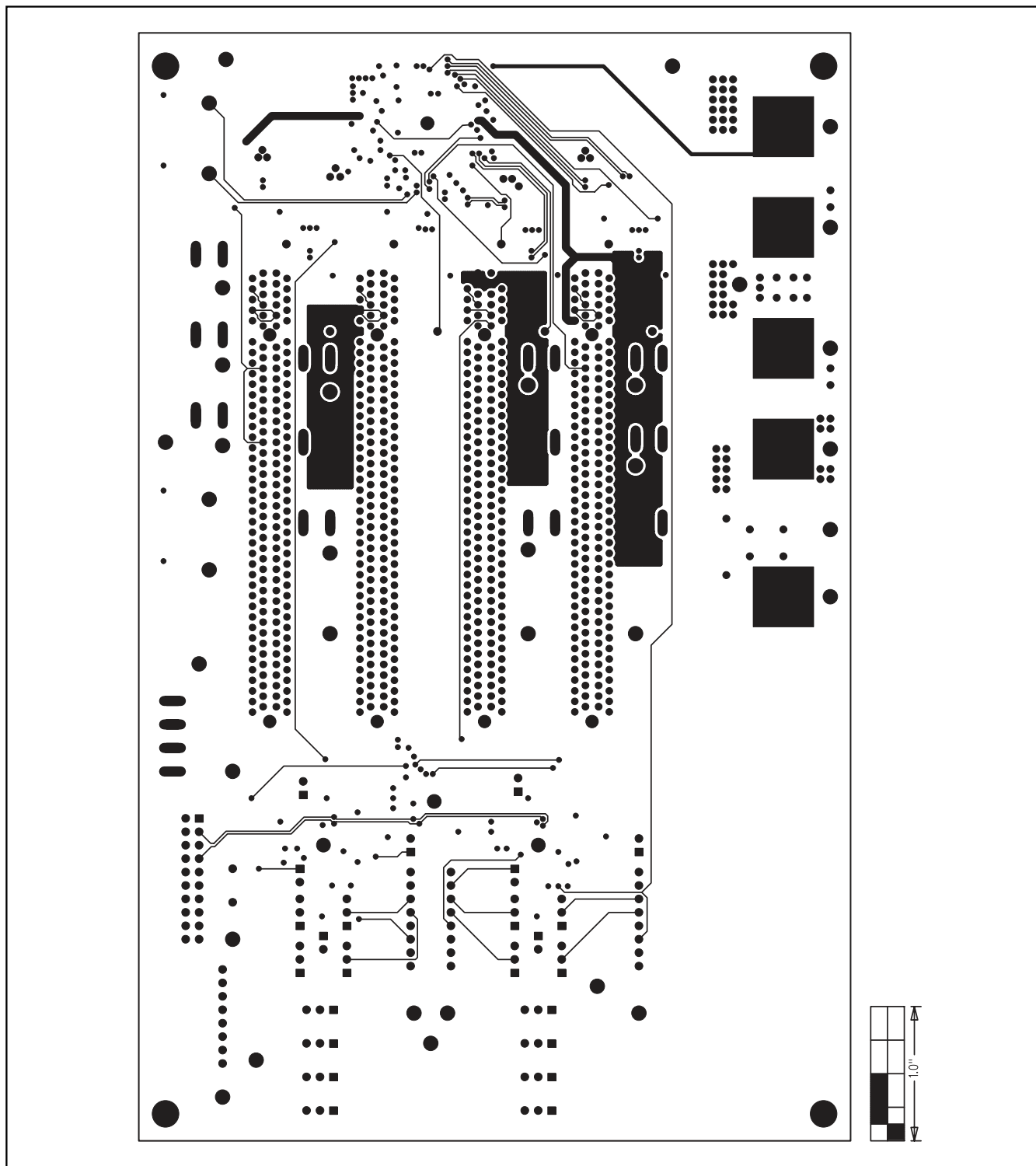

Figure 13. MAX5960L EV Kit PCB Layout—Inner Layer, Signal Layer 5

MAX5960L Evaluation Kit/ Evaluation System

Evaluate: MAX5959A/MAX5959L/MAX5960A/MAX5960L

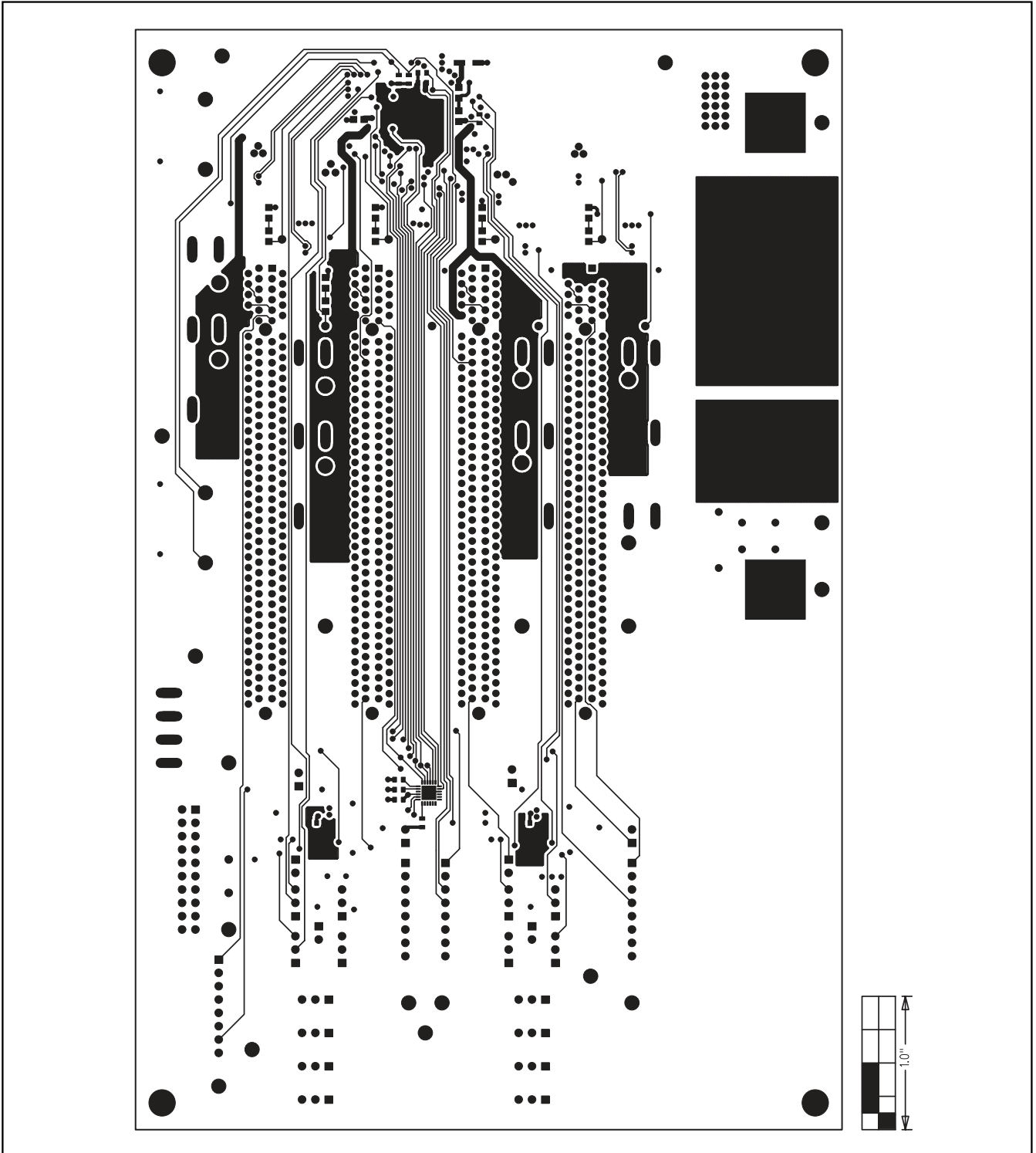

Figure 14. MAX5960L EV Kit PCB Layout—Solder Side

MAX5960L Evaluation Kit/ Evaluation System

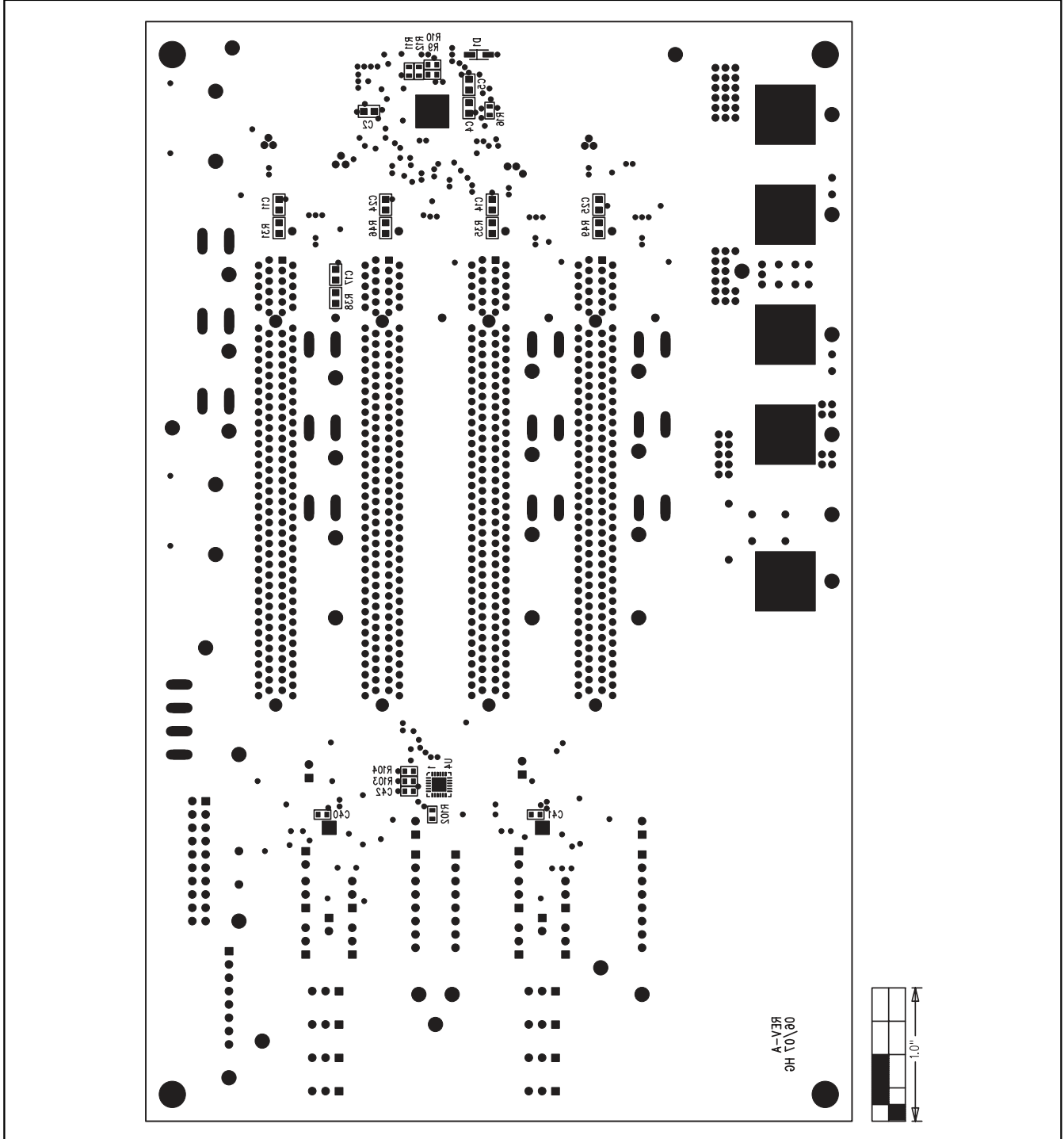

Figure 15. MAX5960L EV Kit Component Placement Guide—Solder Side

Maxim cannot assume responsibility for use of any circuitry other than circuitry entirely embodied in a Maxim product. No circuit patent licenses are implied. Maxim reserves the right to change the circuitry and specifications without notice at any time.