

**Benefits**

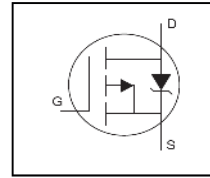
- Advanced Process Technology
- Surface Mount (IRF9530NS)
- Low-profile through-hole(IRF9530NL)
- 175°C Operating Temperature
- Fast Switching
- P-Channel
- Fully Avalanche Rated
- Lead-Free

**Description**

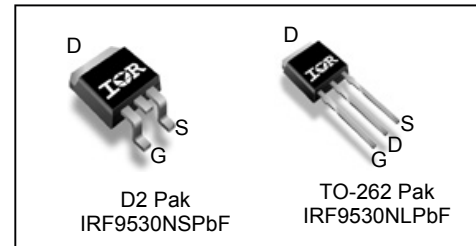
Fifth Generation HEXFET® Power MOSFETs from International Rectifier utilize advanced processing techniques to achieve extremely low on-resistance per silicon area. This benefit, combined with the fast switching speed and ruggedized device design that HEXFET power MOSFETs are well known for, provides the designer with an extremely efficient and reliable device for use in a wide variety of applications.

The D2Pak is a surface mount power package capable of accommodating die sizes up to HEX-4. It provides the highest power capability and the lowest possible on-resistance in any existing surface mount package. The D2Pak is suitable for high current applications because of its low internal connection resistance and can dissipate up to 2.0W in a typical surface mount application.

The through-hole version (IRF9530NL) is available for low-profile applications.

**HEXFET® Power MOSFET**


|                           |              |
|---------------------------|--------------|
| <b>V<sub>DSS</sub></b>    | <b>-100V</b> |
| <b>R<sub>DS(on)</sub></b> | <b>0.20Ω</b> |
| <b>I<sub>D</sub></b>      | <b>-14A</b>  |



|          |          |          |
|----------|----------|----------|
| <b>G</b> | <b>D</b> | <b>S</b> |
| Gate     | Drain    | Source   |

| Base part number | Package Type | Standard Pack      |          | Orderable Part Number   |
|------------------|--------------|--------------------|----------|-------------------------|
|                  |              | Form               | Quantity |                         |
| IRF9530NLPbF     | TO-262       | Tube               | 50       | IRF9530NLPbF (Obsolete) |
| IRF9530NSPbF     | D2-Pak       | Tape and Reel Left | 800      | IRF9530NSTRLPbF         |

**Absolute Maximum Ratings**

| Symbol                                  | Parameter   | Max.               | Units |
|---|---|--------------------|-------|
| I <sub>D</sub> @ T <sub>C</sub> = 25°C  | Continuous Drain Current, V <sub>GS</sub> @ -10V ⑤      | -14                | A     |
| I <sub>D</sub> @ T <sub>C</sub> = 100°C | Continuous Drain Current, V <sub>GS</sub> @ -10V ⑤      | -10                |       |
| I <sub>DM</sub>                         | Pulsed Drain Current ①⑤                                 | -56                |       |
| P <sub>D</sub> @ T <sub>A</sub> = 25°C  | Maximum Power Dissipation                               | 3.8                | W     |
| P <sub>D</sub> @ T <sub>C</sub> = 25°C  | Maximum Power Dissipation                               | 79                 | W     |
|   | Linear Derating Factor                                  | 0.53               | W/°C  |
| V <sub>GS</sub>                         | Gate-to-Source Voltage                                  | ± 20               | V     |
| E <sub>AS</sub>                         | Single Pulse Avalanche Energy (Thermally Limited) ②⑤    | 250                | mJ    |
| I <sub>AR</sub>                         | Avalanche Current ①                                     | -8.4               | A     |
| E <sub>AR</sub>                         | Repetitive Avalanche Energy ①                           | 7.9                | mJ    |
| dv/dt                                   | Peak Diode Recovery dv/dt③⑤                             | -5.0               | V/ns  |
| T <sub>J</sub>                          | Operating Junction and                                  | -55 to + 175       | °C    |
| T <sub>STG</sub>                        | Storage Temperature Range                               |                    |       |
|   | Soldering Temperature, for 10 seconds (1.6mm from case) |                    |       |
|   | Mounting torque, 6-32 or M3 screw                       | 10 lbf•in (1.1N•m) |       |


**Thermal Resistance**

| Symbol           | Parameter  | Typ. | Max. | Units |
|------------------|--|------|------|-------|
| R <sub>θJC</sub> | Junction-to-Case                                 | —    | 1.9  | °C/W  |
| R <sub>θJA</sub> | Junction-to-Ambient ( PCB Mount, steady state) ⑥ | —    | 40   |       |

**Electrical Characteristics @  $T_J = 25^\circ\text{C}$  (unless otherwise specified)**

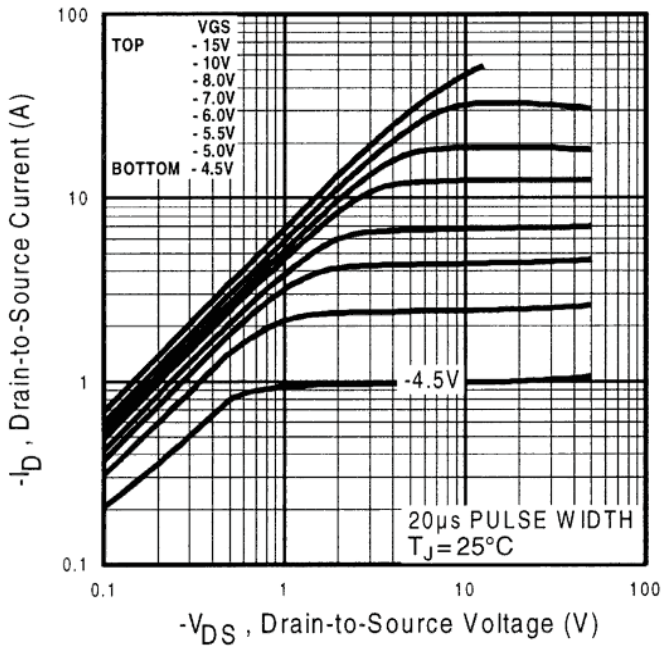
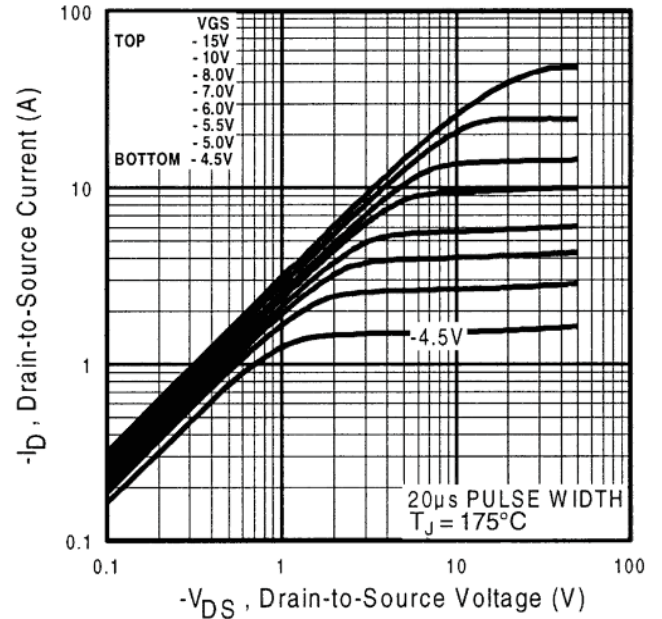
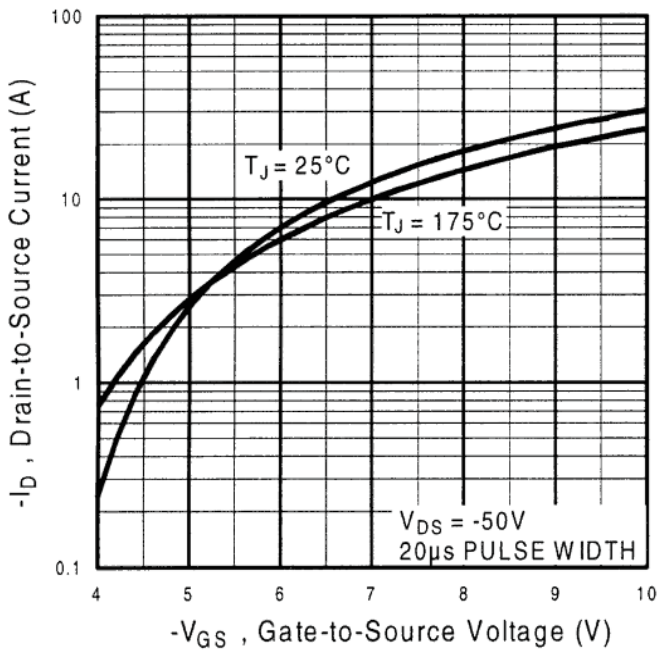
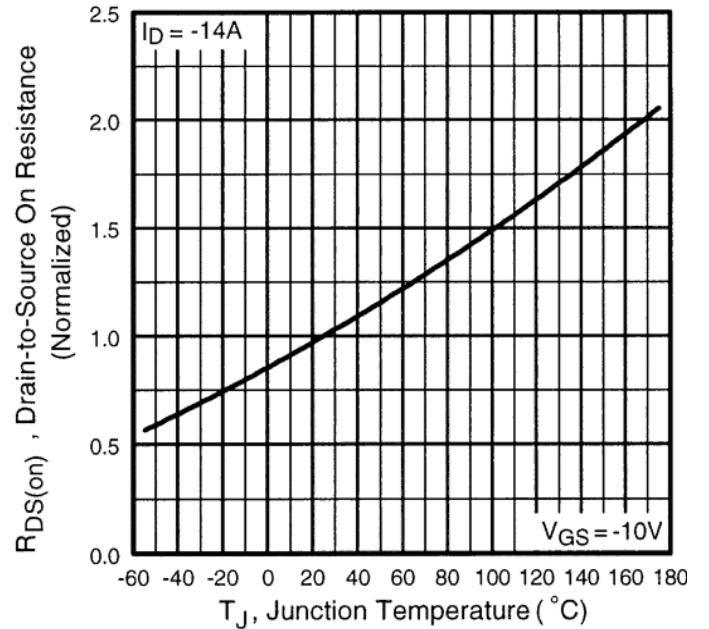
|                                 | Parameter                            | Min. | Typ.  | Max. | Units               | Conditions  |
|---------------------------------|--------------------------------------|------|-------|------|---------------------|---|
| $V_{(BR)DSS}$                   | Drain-to-Source Breakdown Voltage    | -100 | —     | —    | V                   | $V_{GS} = 0V, I_D = -250\mu A$                          |
| $\Delta V_{(BR)DSS}/\Delta T_J$ | Breakdown Voltage Temp. Coefficient  | —    | -0.11 | —    | V/ $^\circ\text{C}$ | Reference to $25^\circ\text{C}$ , $I_D = -1\text{mA}$ ⑤ |
| $R_{DS(on)}$                    | Static Drain-to-Source On-Resistance | —    | —     | 0.20 | $\Omega$            | $V_{GS} = -10V, I_D = -8.4A$ ④                          |
| $V_{GS(th)}$                    | Gate Threshold Voltage               | -2.0 | —     | -4.0 | V                   | $V_{DS} = V_{GS}, I_D = -250\mu A$                      |
| $g_{fs}$                        | Forward Trans conductance            | 3.2  | —     | —    | S                   | $V_{DS} = -50V, I_D = -8.4A$ ⑤                          |
| $I_{DSS}$                       | Drain-to-Source Leakage Current      | —    | —     | -25  | $\mu A$             | $V_{DS} = -100V, V_{GS} = 0V$                           |
|                                 |                                      | —    | —     | -250 |                     | $V_{DS} = -80V, V_{GS} = 0V, T_J = 150^\circ\text{C}$   |
| $I_{GSS}$                       | Gate-to-Source Forward Leakage       | —    | —     | -100 | nA                  | $V_{GS} = -20V$   |
|                                 | Gate-to-Source Reverse Leakage       | —    | —     | 100  |                     | $V_{GS} = 20V$  |
| $Q_g$                           | Total Gate Charge                    | —    | —     | 58   | nC                  | $I_D = -8.4A$   |
| $Q_{gs}$                        | Gate-to-Source Charge                | —    | —     | 8.3  |                     | $V_{DS} = -80V$   |
| $Q_{gd}$                        | Gate-to-Drain Charge                 | —    | —     | 32   |                     | $V_{GS} = -10V$ See Fig.6 and 13 ④ ⑤                    |
| $t_{d(on)}$                     | Turn-On Delay Time                   | —    | 15    | —    | ns                  | $V_{DD} = -50V$   |
| $t_r$                           | Rise Time                            | —    | 58    | —    |                     | $I_D = -8.4A$   |
| $t_{d(off)}$                    | Turn-Off Delay Time                  | —    | 45    | —    |                     | $R_G = 9.1\Omega$                                       |
| $t_f$                           | Fall Time                            | —    | 46    | —    |                     | $R_D = 6.2\Omega$ See Fig.6 ④ ⑤                         |
| $L_S$                           | Internal Source Inductance           | —    | 7.5   | —    | nH                  | Between lead,<br>and center of die contact              |
| $C_{iss}$                       | Input Capacitance                    | —    | 760   | —    | pF                  | $V_{GS} = 0V$   |
| $C_{oss}$                       | Output Capacitance                   | —    | 260   | —    |                     | $V_{DS} = -25V$   |
| $C_{rss}$                       | Reverse Transfer Capacitance         | —    | 170   | —    |                     | $f = 1.0\text{MHz}$ , See Fig. 5 ⑤                      |

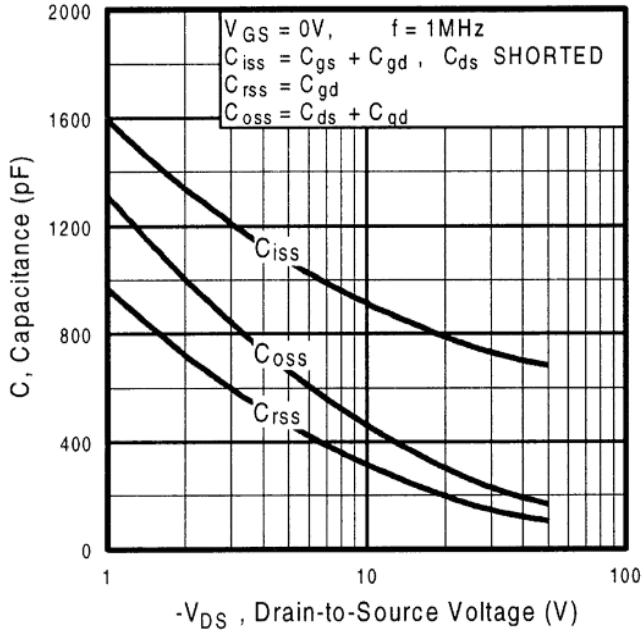
**Source-Drain Ratings and Characteristics**

|          | Parameter                                 | Min.  | Typ. | Max. | Units | Conditions  |
|----------|---|---|------|------|-------|---|
| $I_S$    | Continuous Source Current<br>(Body Diode) | —   | —    | -14  | A     | MOSFET symbol<br>showing the<br>integral reverse<br>p-n junction diode.  |
| $I_{SM}$ | Pulsed Source Current<br>(Body Diode) ①   | —   | —    | -56  |       |   |
| $V_{SD}$ | Diode Forward Voltage                     | —   | —    | -1.6 | V     | $T_J = 25^\circ\text{C}, I_S = -8.4A, V_{GS} = 0V$ ④  |
| $t_{rr}$ | Reverse Recovery Time                     | —   | 130  | 190  | ns    | $T_J = 25^\circ\text{C}, I_F = -8.4A$   |
| $Q_{rr}$ | Reverse Recovery Charge                   | —   | 650  | 970  | nC    | $di/dt = -100A/\mu s$ ④ ⑤   |
| $t_{on}$ | Forward Turn-On Time                      | Intrinsic turn-on time is negligible (turn-on is dominated by $L_S+L_D$ ) |      |      |       |   |

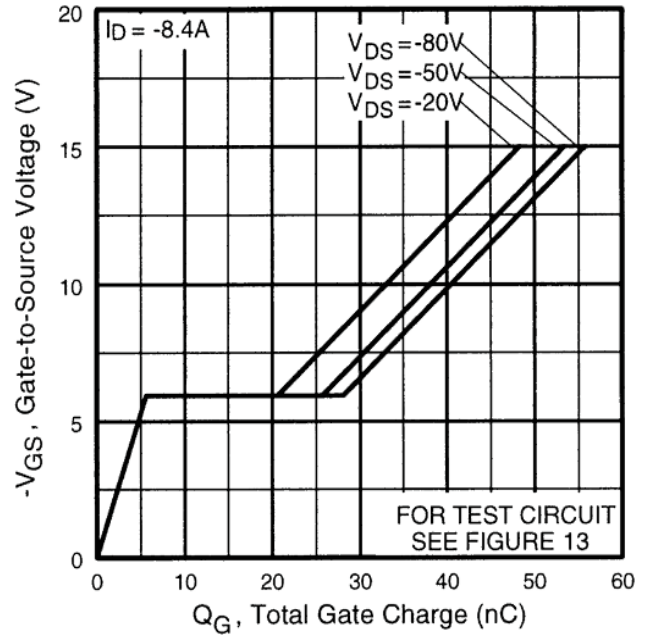
**Notes:**

- ① Repetitive rating; pulse width limited by max. junction temperature. (See fig. 11)
- ② starting  $T_J = 25^\circ\text{C}$ ,  $L = 7.0\text{mH}$ ,  $R_G = 25\Omega$ ,  $I_{AS} = -8.4A$ . (See fig. 12)
- ③  $I_{SD} \leq -8.4A$ ,  $di/dt \leq -490A/\mu s$ ,  $V_{DD} \leq V_{(BR)DSS}$ ,  $T_J \leq 175^\circ\text{C}$ .
- ④ Pulse width  $\leq 300\mu s$ ; duty cycle  $\leq 2\%$ .
- ⑤ Uses IRF9530N data and test conditions.
- ⑥ When mounted on 1" square PCB (FR-4 or G-10 Material). For recommended footprint and soldering techniques refer to application note #AN-994

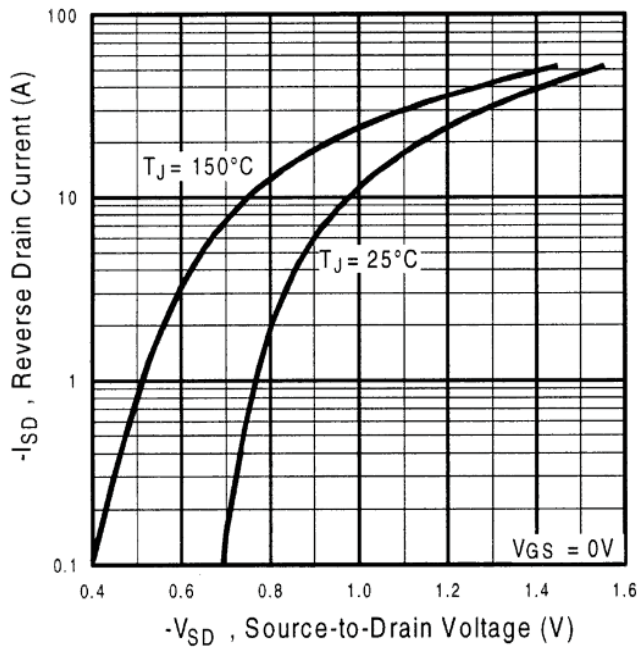

**Fig. 1 Typical Output Characteristics**

**Fig. 2 Typical Output Characteristics**

**Fig. 3 Typical Transfer Characteristics**

**Fig. 4 Normalized On-Resistance vs. Temperature**



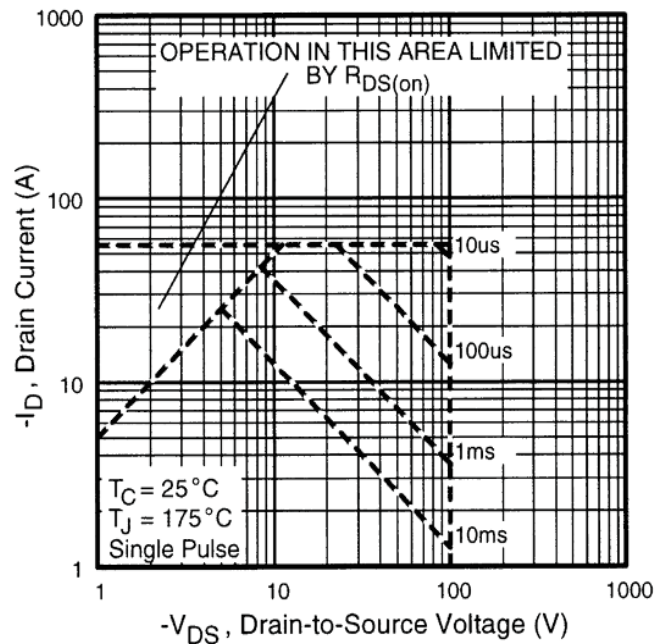
**Fig 5.** Typical Capacitance vs. Drain-to-Source Voltage



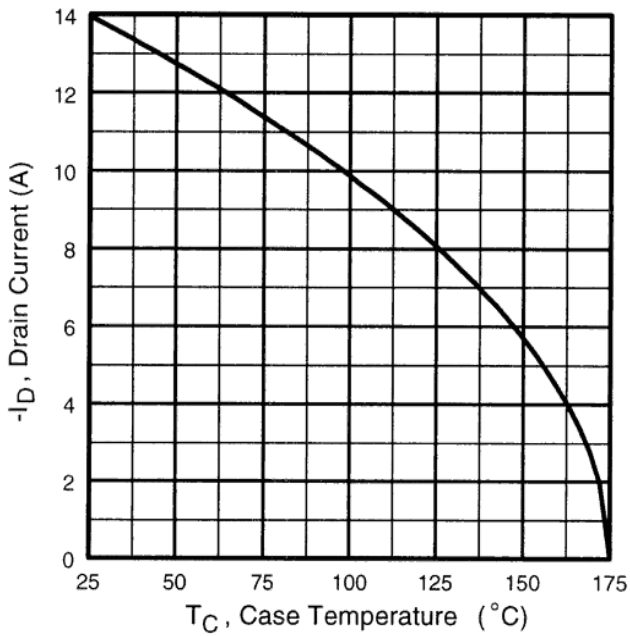
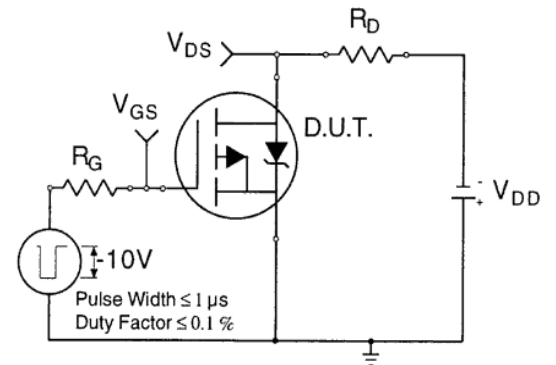
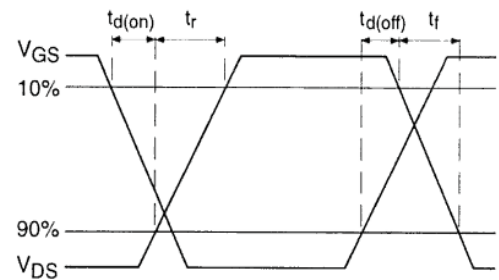
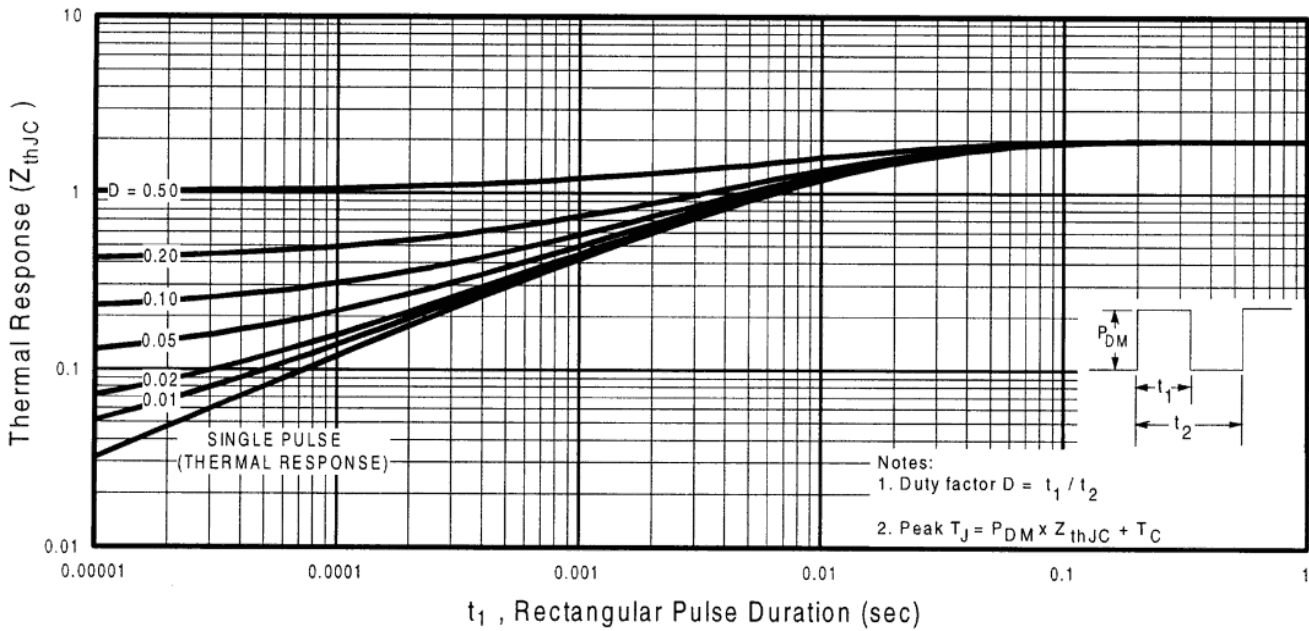
**Fig 6.** Typical Gate Charge vs. Gate-to-Source Voltage

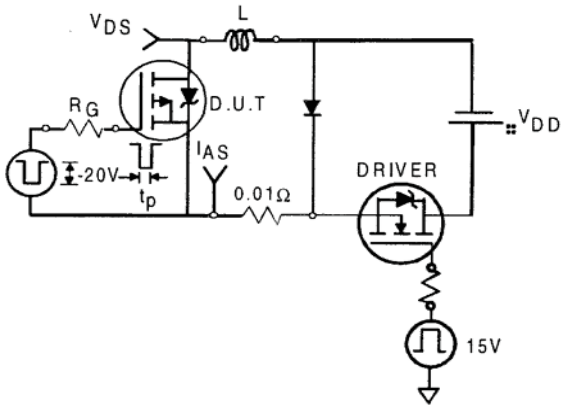
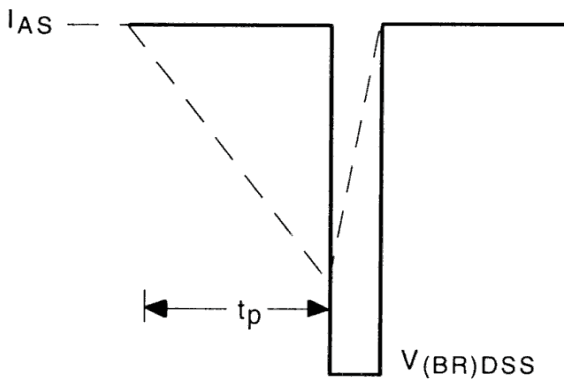
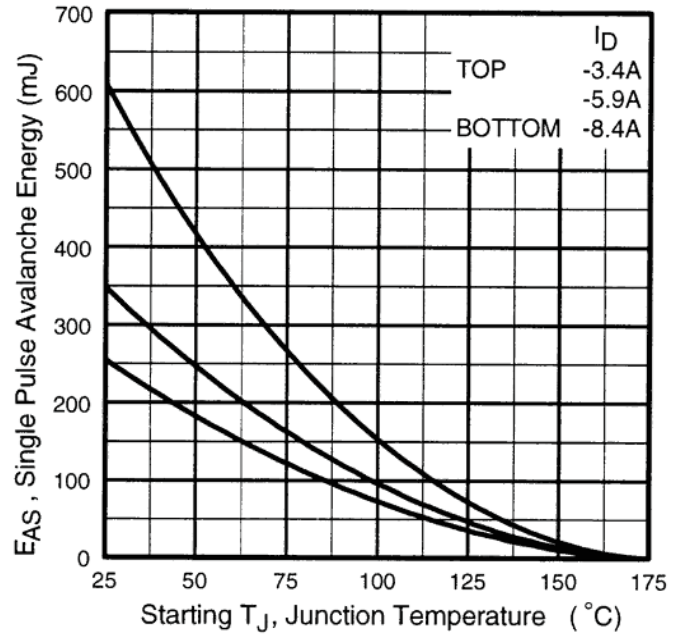
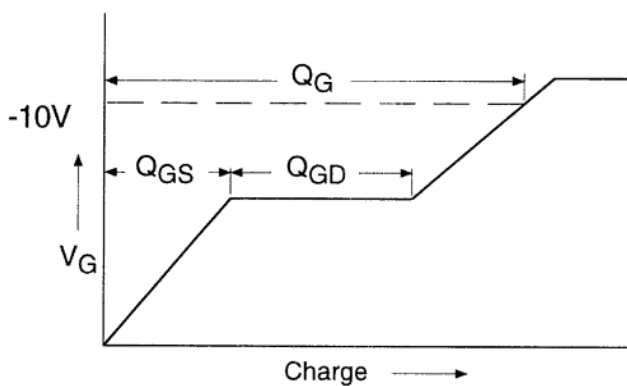
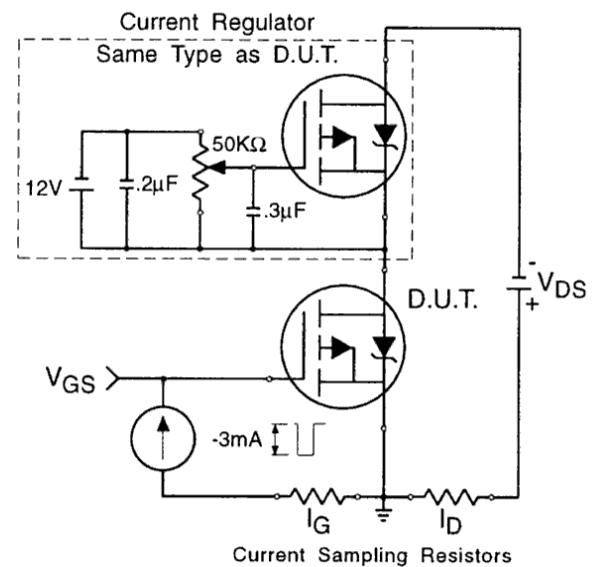


**Fig 7** Typical Source-to-Drain Diode Forward Voltage

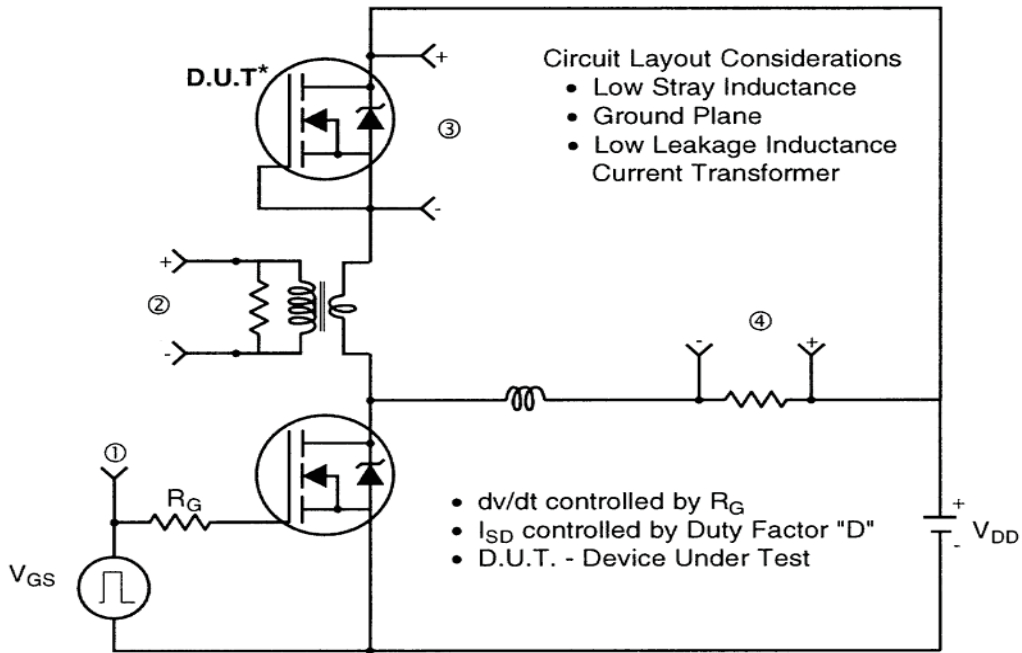


**Fig 8.** Maximum Safe Operating Area

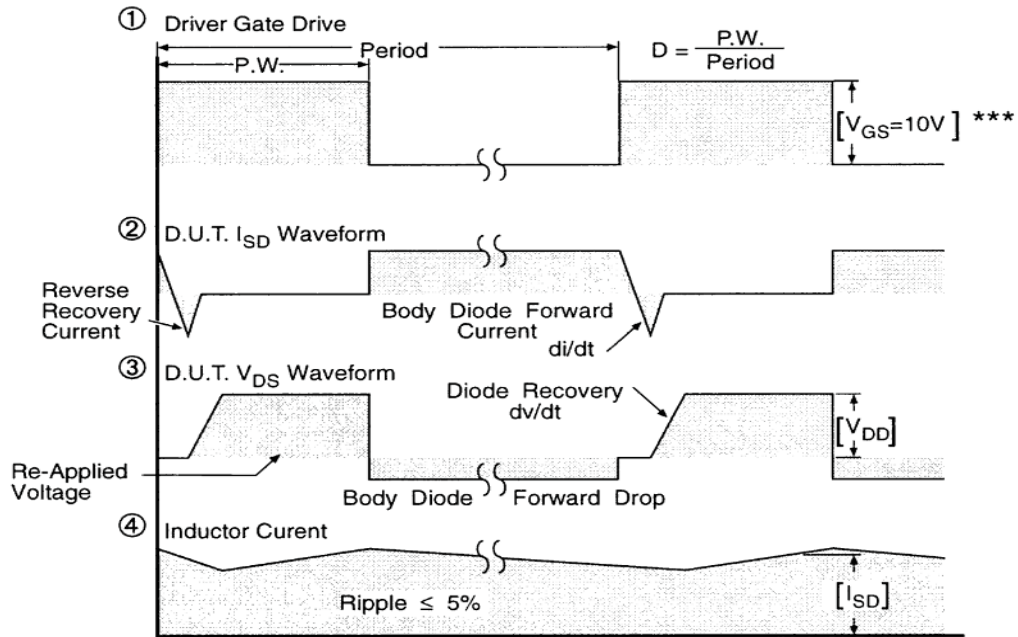

**Fig 9.** Maximum Drain Current vs. Case Temperature

**Fig 10a.** Switching Time Test Circuit

**Fig 10b.** Switching Time Waveforms

**Fig 11.** Maximum Effective Transient Thermal Impedance, Junction-to-Case


**Fig 12a.** Unclamped Inductive Test Circuit

**Fig 12b.** Unclamped Inductive Waveforms

**Fig 12c.** Maximum Avalanche Energy vs. Drain Current

**Fig 13a.** Gate Charge Waveform

**Fig 13b.** Gate Charge Test Circuit

### Peak Diode Recovery dv/dt Test Circuit

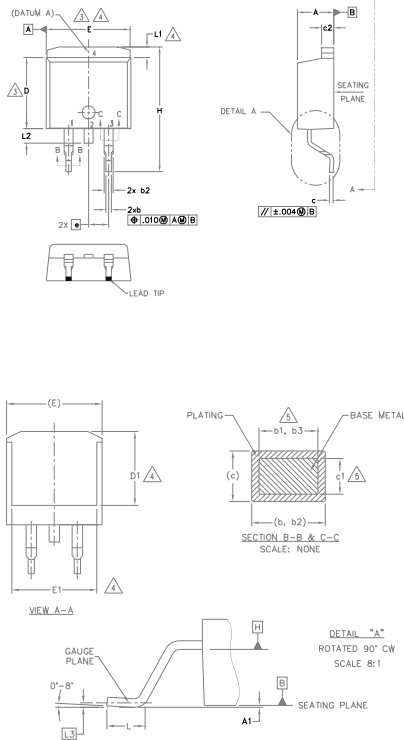


\* Reverse Polarity of D.U.T for P-Channel



\*\*\*  $V_{GS} = 5.0V$  for Logic Level and 3V Drive Devices

**Fig 14.** Peak Diode Recovery  $dv/dt$  Test Circuit for PChannel HEXFET® Power MOSFETs

**D2-Pak (TO-263AB) Package Outline (Dimensions are shown in millimeters (inches))**

**NOTES:**

1. DIMENSIONING AND TOLERANCING PER ASME Y14.5M-1994
2. DIMENSIONS ARE SHOWN IN MILLIMETERS [INCHES].
3. DIMENSION D & E DO NOT INCLUDE MOLD FLASH. MOLD FLASH SHALL NOT EXCEED 0.127 [".005"] PER SIDE. THESE DIMENSIONS ARE MEASURED AT THE OUTMOST EXTREMES OF THE PLASTIC BODY AT DATUM H.
4. THERMAL PAD CONTOUR OPTIONAL WITHIN DIMENSION E, L1, D1 & E1.
5. DIMENSION b1, b3 AND c1 APPLY TO BASE METAL ONLY.
6. DATUM A & B TO BE DETERMINED AT DATUM PLANE H.
7. CONTROLLING DIMENSION: INCH.
8. OUTLINE CONFORMS TO JEDEC OUTLINE TO-263AB.

| SYMBOL | DIMENSIONS  |       |          |      | NOTES |
|--------|-------------|-------|----------|------|-------|
|        | MILLIMETERS |       | INCHES   |      |       |
|        | MIN.        | MAX.  | MIN.     | MAX. |       |
| A      | 4.06        | 4.83  | .160     | .190 |       |
| A1     | 0.00        | 0.254 | .000     | .010 |       |
| b      | 0.51        | 0.99  | .020     | .039 |       |
| b1     | 0.51        | 0.89  | .020     | .035 | 5     |
| b2     | 1.14        | 1.78  | .045     | .070 |       |
| b3     | 1.14        | 1.73  | .045     | .068 | 5     |
| c      | 0.38        | 0.74  | .015     | .029 |       |
| c1     | 0.38        | 0.58  | .015     | .023 | 5     |
| c2     | 1.14        | 1.65  | .045     | .065 |       |
| D      | 8.38        | 9.65  | .330     | .380 | 3     |
| D1     | 6.86        | —     | .270     | —    | 4     |
| E      | 9.65        | 10.67 | .380     | .420 | 3,4   |
| E1     | 6.22        | —     | .245     | —    | 4     |
| e      | 2.54 BSC    |       | .100 BSC |      |       |
| H      | 14.61       | 15.88 | .575     | .625 |       |
| L      | 1.78        | 2.79  | .070     | .110 |       |
| L1     | —           | 1.68  | —        | .066 | 4     |
| L2     | —           | 1.78  | —        | .070 |       |
| L3     | 0.25 BSC    |       | .010 BSC |      |       |

**LEAD ASSIGNMENTS**
**DIODES**

- 1.- ANODE (TWO DIE) / OPEN (ONE DIE)
- 2, 4.- CATHODE
- 3.- ANODE

**HEXFET**

- 1.- GATE
- 2, 4.- DRAIN
- 3.- SOURCE

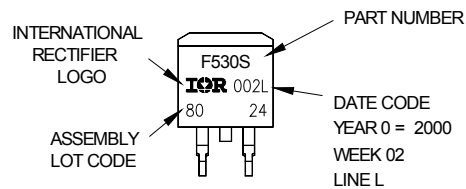
**IGBTs, CoPACK**

- 1.- GATE
- 2, 4.- COLLECTOR
- 3.- EMITTER

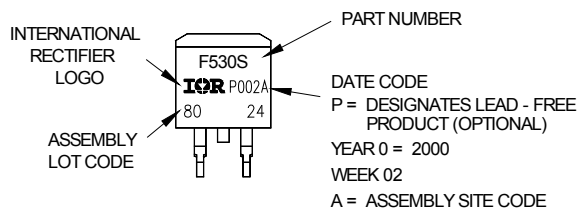
**D2-Pak (TO-263AB) Part Marking Information**

EXAMPLE: THIS IS AN IRF530S WITH  
LOT CODE 8024  
ASSEMBLED ON WW 02, 2000  
IN THE ASSEMBLY LINE "L"

Note: "P" in assembly line position  
indicates "Lead - Free"

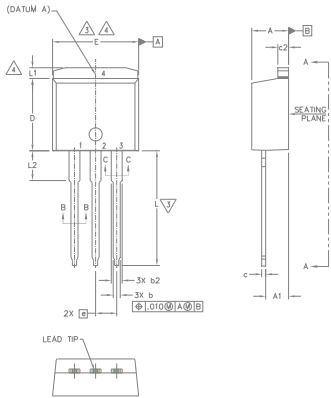


OR



Note: For the most current drawing please refer to Infineon's web site [www.infineon.com](http://www.infineon.com)



**TO-262 Package Outline (Dimensions are shown in millimeters (inches))**


- NOTES:
1. DIMENSIONING AND TOLERANCING PER ASME Y14.5M-1994
  2. DIMENSIONS ARE SHOWN IN MILLIMETERS [INCHES].
  3. DIMENSION D & E DO NOT INCLUDE MOLD FLASH. MOLD FLASH SHALL NOT EXCEED 0.127 [.005"] PER SIDE. THESE DIMENSIONS ARE MEASURED AT THE OUTMOST EXTREMES OF THE PLASTIC BODY.
  4. THERMAL PAD CONTOUR OPTIONAL WITHIN DIMENSION E, L1, D1 & E1.
  5. DIMENSION b1 AND c1 APPLY TO BASE METAL ONLY.
  6. CONTROLLING DIMENSION: INCH.
  7. OUTLINE CONFORM TO JEDEC TO-262 EXCEPT A1(max.), b(min.) AND D1(min.) WHERE DIMENSIONS DERIVED THE ACTUAL PACKAGE OUTLINE.

**LEAD ASSIGNMENTS**
**IGBTs, CoPACK**

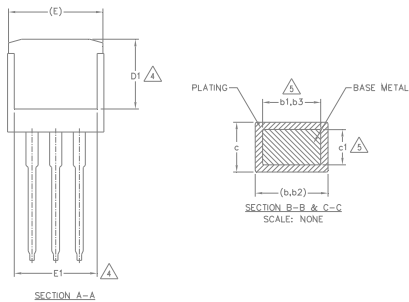
- 1.- GATE
- 2.- COLLECTOR
- 3.- EMITTER
- 4.- COLLECTOR

**HEXFET**

- 1.- GATE
- 2.- DRAIN
- 3.- SOURCE
- 4.- DRAIN

**DIODES**

- 1.- ANODE (TWO DIE) / OPEN (ONE DIE)
- 2, 4.- CATHODE
- 3.- ANODE

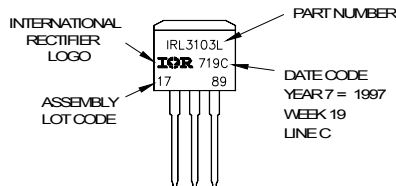


| SYMBOL | DIMENSIONS  |       |          |      | NOTES |
|--------|-------------|-------|----------|------|-------|
|        | MILLIMETERS |       | INCHES   |      |       |
|        | MIN.        | MAX.  | MIN.     | MAX. |       |
| A      | 4.06        | 4.83  | .160     | .190 |       |
| A1     | 2.03        | 3.02  | .080     | .119 |       |
| b      | 0.51        | 0.99  | .020     | .039 |       |
| b1     | 0.51        | 0.89  | .020     | .035 | 5     |
| b2     | 1.14        | 1.78  | .045     | .070 |       |
| b3     | 1.14        | 1.73  | .045     | .068 | 5     |
| c      | 0.38        | 0.74  | .015     | .029 |       |
| c1     | 0.38        | 0.58  | .015     | .023 | 5     |
| c2     | 1.14        | 1.65  | .045     | .065 |       |
| D      | 8.38        | 9.65  | .330     | .380 | 3     |
| D1     | 6.86        | -     | .270     | -    | 4     |
| E      | 9.65        | 10.67 | .380     | .420 | 3,4   |
| E1     | 6.22        | -     | .245     | -    | 4     |
| e      | 2.54 BSC    |       | .100 BSC |      |       |
| L      | 13.46       | 14.10 | .530     | .555 |       |
| L1     | -           | 1.65  | -        | .065 | 4     |
| L2     | 3.56        | 3.71  | .140     | .146 |       |

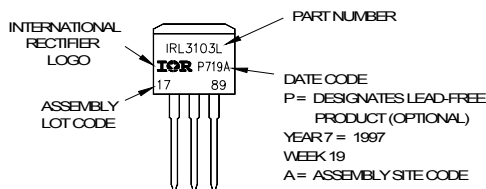
**TO-262 Part Marking Information**

EXAMPLE: THIS IS AN IRL3103L  
 LOT CODE 1789  
 ASSEMBLED ON WW19, 1997  
 IN THE ASSEMBLY LINE "C"

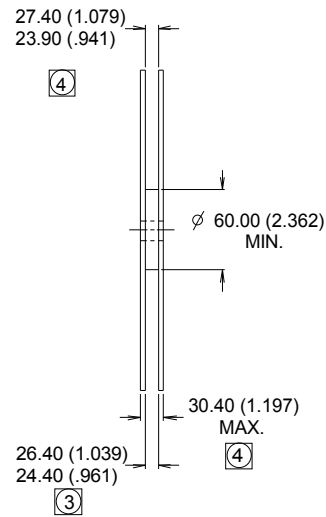
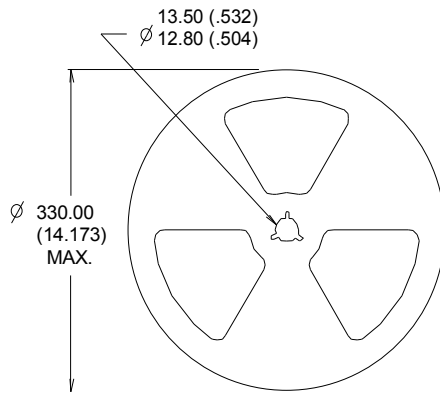
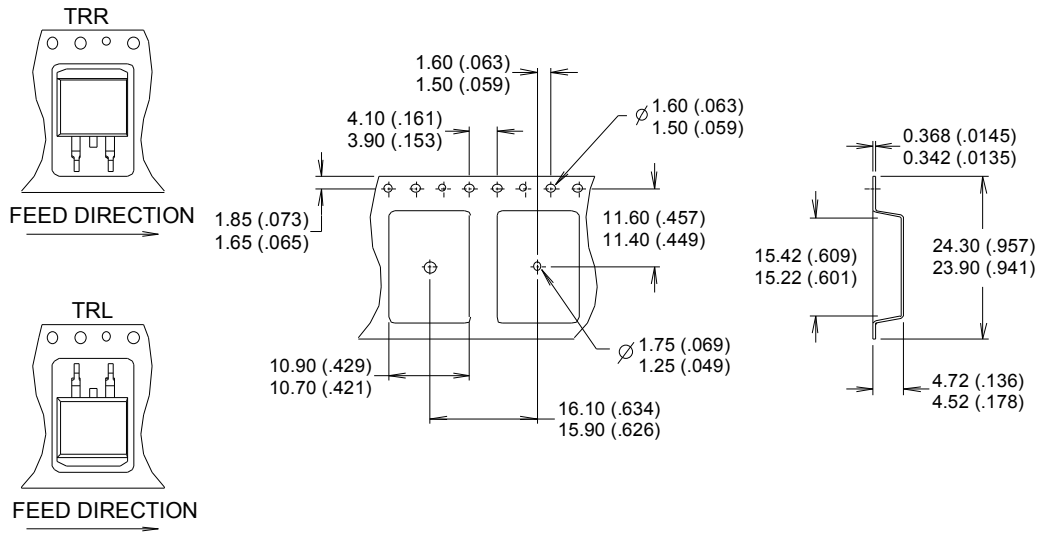
Note: "P" in assembly line position indicates "Lead - Free"



OR



Note: For the most current drawing please refer to Infineon's web site [www.infineon.com](http://www.infineon.com)

**D2-Pak (TO-263AB) Tape & Reel Information (Dimensions are shown in millimeters (inches))**

**NOTES :**

1. CONFORMS TO EIA-418.
2. CONTROLLING DIMENSION: MILLIMETER.
- ③ DIMENSION MEASURED @ HUB.
- ④ INCLUDES FLANGE DISTORTION @ OUTER EDGE.

Note: For the most current drawing please refer to Infineon's web site [www.infineon.com](http://www.infineon.com)

**Qualification Information†**

|                                   |                                      |                                   |
|-----------------------------------|--------------------------------------|-----------------------------------|
| <b>Qualification Level</b>        | Industrial<br>(per JEDEC JESD47F) †† |                                   |
| <b>Moisture Sensitivity Level</b> | D2-Pak                               | MSL1<br>(per JEDEC J-STD-020D) †† |
|                                   | TO-262                               | N/A                               |
| <b>RoHS Compliant</b>             | Yes                                  |                                   |

† Qualification standards can be found at Infineon’s web site [www.infineon.com](http://www.infineon.com)

†† Applicable version of JEDEC standard at the time of product release.

**Revision History**

| Date      | Comments  |
|-----------|---|
| 5/27/2016 | <ul style="list-style-type: none"> <li>Updated datasheet with corporate template.</li> <li>Added disclaimer on last page.</li> <li>TO-262 package was removed from ordering information since it is EOL on page 1.</li> </ul> |

**Trademarks of Infineon Technologies AG**

μHVIC™, μIPM™, μPFC™, AU-ConvertIR™, AURIX™, C166™, CanPAK™, CIPOS™, CIPURSE™, CoolDP™, CoolGaN™, COOLiR™, CoolMOS™, CoolSET™, CoolSiC™, DAVE™, DI-POL™, DirectFET™, DrBlade™, EasyPIM™, EconoBRIDGE™, EconoDUAL™, EconoPACK™, EconoPIM™, EiceDRIVER™, eupec™, FCOS™, GaNpowIR™, HEXFET™, HITFET™, HybridPACK™, iMOTION™, IRAM™, ISOFACE™, IsoPACK™, LEDrivr™, LITIX™, MIPAQ™, ModSTACK™, my-d™, NovalithIC™, OPTIGA™, OptiMOS™, ORIGA™, PowIRaudio™, PowIRstage™, PrimePACK™, PrimeSTACK™, PROFET™, PRO-SiL™, RASIC™, REAL3™, SmartLEWIS™, SOLID FLASH™, SPOC™, StrongIRFET™, SupIRBuck™, TEMPFET™, TRENCHSTOP™, TriCore™, UHVIC™, XHP™, XMC™

Trademarks updated November 2015

**Other Trademarks**

All referenced product or service names and trademarks are the property of their respective owners.

**Edition 2016-04-19**

**Published by**

**Infineon Technologies AG**  
81726 Munich, Germany

© 2016 Infineon Technologies AG.  
All Rights Reserved.

**Do you have a question about this document?**

Email: [erratum@infineon.com](mailto:erratum@infineon.com)

**Document reference**

ifx1

**IMPORTANT NOTICE**

The information given in this document shall in no event be regarded as a guarantee of conditions or characteristics (“**Beschaffensgarantie**”).

With respect to any examples, hints or any typical values stated herein and/or any information regarding the application of the product, Infineon Technologies hereby disclaims any and all warranties and liabilities of any kind, including without limitation warranties of non-infringement of intellectual property rights of any third party.

In addition, any information given in this document is **subject to customer’s compliance with its obligations** stated in this document and any applicable legal requirements, norms and standards concerning customer’s products and any use of the product of Infineon Technologies in **customer’s applications**.

The data contained in this document is exclusively intended for technically trained staff. It is the **responsibility of customer’s technical departments** to evaluate the suitability of the product for the intended application and the completeness of the product information given in this document with respect to such application.

For further information on the product, technology, delivery terms and conditions and prices please contact your nearest Infineon Technologies office ([www.infineon.com](http://www.infineon.com)).

Please note that this product is not qualified according to the AEC Q100 or AEC Q101 documents of the Automotive Electronics Council.

**WARNINGS**

Due to technical requirements products may contain dangerous substances. For information on the types in question please contact your nearest Infineon Technologies office.

Except as otherwise explicitly approved by Infineon Technologies in a written document signed by authorized representatives of Infineon Technologies, **Infineon Technologies’ products may not be used** in any applications where a failure of the product or any consequences of the use thereof can reasonably be expected to result in personal injury.