

FEATURES

- Total composite power: 73.3 dBmV**
- High power gain: 25.0 dB at 1218 MHz**
- Excellent linearity**
- Very low distortion**
 - Composite triple beat: –80 dBc typical**
 - Composite second-order: –78 dBc typical**
 - Carrier to intermodulation noise: 58 dB typical**
- Low noise figure: 3 dB at 45 MHz and 4 dB at 1218 MHz**
- Unconditionally stable**
- Transient and surge protection**
- Configurable current: 250 mA to 490 mA at 24 V**

APPLICATIONS

- 45 MHz to 1218 MHz community access television (CATV) infrastructure amplifier systems**
- Remote physical layer (PHY)**
- DOCSIS 3.1 compliant**

GENERAL DESCRIPTION

The Analog Devices, Inc., [ADCA3952](#) is a power doubler hybrid module packaged in the industry-standard [SOT-115J package](#). The device achieves high RF output, up to 73.3 dBmV total composite power with 9 dB tilt, by using advanced circuit design techniques, such as gallium arsenide (GaAs), pseudomorphic high electron transistor (pHEMT), and gallium nitride (GaN) HEMT technologies. The dc current can be adjusted externally for optimum distortion performance vs. power consumption over a range of output levels. The ADCA3952 provides high gain, simplifying the design and manufacturing of DOCSIS 3.1™ infrastructure equipment.

FUNCTIONAL BLOCK DIAGRAM

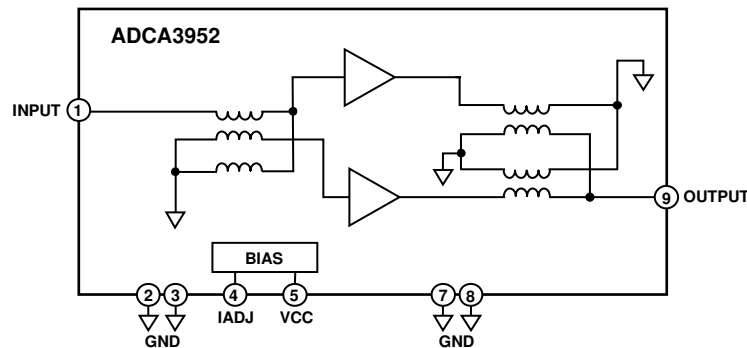

Figure 1.

TABLE OF CONTENTS

Features	1	ESD Caution	5
Applications	1	Pin Configuration and Function Descriptions	6
General Description	1	Typical Performance Characteristics	7
Functional Block Diagram	1	S-Parameters	7
Revision History	2	9 dB Tilt Performance	8
Specifications	3	Theory of Operation	9
General Performance	3	Applications Information	10
Distortion Data (40 MHz to 550 MHz), Error Rates, and Total Composite Power	4	Outline Dimensions	12
Absolute Maximum Ratings	5	Ordering Guide	12

REVISION HISTORY

11/2020—Revision 0: Initial Version

SPECIFICATIONS

GENERAL PERFORMANCE

Supply voltage (V_{CC}) = 24 V, flange temperature (T_{FLANGE}) = 35°C, source impedance (Z_s) = load impedance (Z_L) = 75 Ω , and IADJ (Pin 4) floating, unless otherwise noted.

Table 1.

Parameter	Symbol	Min	Typ	Max	Unit	Test Conditions/Comments		
POWER GAIN	S21		23.5		dB	Frequency = 45 MHz		
			25.0		dB	Frequency = 1218 MHz		
SLOPE STRAIGHT LINE ¹			1.0		dB	Frequency = 45 MHz to 1218 MHz		
FLATNESS OF FREQUENCY RESPONSE ²			0.6		dB	Frequency = 45 MHz to 1218 MHz		
REVERSE ISOLATION	S12		-28		dB	Frequency = 45 MHz to 1218 MHz		
RETURN LOSS						See Figure 3 and Figure 6		
Input	S11		-20		dB	Frequency = 45 MHz to 320 MHz		
			-18		dB	Frequency = 320 MHz to 640 MHz		
			-18		dB	Frequency = 640 MHz to 870 MHz		
			-18		dB	Frequency = 870 MHz to 1000 MHz		
			-16		dB	Frequency = 1000 MHz to 1218 MHz		
		Output	S22		-20		dB	Frequency = 45 MHz to 320 MHz
					-20		dB	Frequency = 320 MHz to 640 MHz
					-20		dB	Frequency = 640 MHz to 870 MHz
	-20				dB	Frequency = 870 MHz to 1000 MHz		
	-18		dB	Frequency = 1000 MHz to 1218 MHz				
NOISE FIGURE			3		dB	Frequency = 45 MHz		
			4		dB	Frequency = 1218 MHz		
SUPPLY						See the Applications Information section for adjusting the bias current and impact on performance		
Maximum Operating Voltage	V_{CC}		24	26	V			
DC Current (Total)	$I_{CC(TOTAL)}$	250	470	490	mA			

¹ Slope straight line is defined as the delta between the gain at the start frequency and the gain at the stop frequency.

² Flatness of frequency response is defined as the delta between the gain at any frequency between the start and stop frequencies and a straight line reference drawn between the gain at the start frequency and the gain at the stop frequency.

DISTORTION DATA (40 MHz TO 550 MHz), ERROR RATES, AND TOTAL COMPOSITE POWER

$V_{CC} = 24\text{ V}$, $T_{FLANGE} = 35^{\circ}\text{C}$, $Z_S = Z_L = 75\ \Omega$, and IADJ (Pin 4) floating, unless otherwise noted.

Table 2.

Parameter	Symbol	Min	Typ	Max	Unit	Test Conditions/Comments
DISTORTION						Total composite power = 72.4 dBmV, 9 dB extrapolated tilt, 79 continuous wave channels plus 111 digital channels, National Television System Committee (NTSC) frequency raster = 55.25 MHz to 547.25 MHz, -6 dB offset
Composite Triple Beat	CTB		-80		dBc	Defined by the National Cable and Telecommunications Association (NCTA)
Composite Second-Order Carrier to Intermodulation Noise	CSO		-78 58		dBc dB	Defined by NCTA Defined by American National Standard/Society of Cable Telecommunications Engineers (ANSI/SCTE) 17 (test procedure for carrier to noise)
ERROR RATES						Total composite power = 72.4 dBmV, 9 dB extrapolated tilt, 190 digital (256 QAMs) channels PreViterbi
Bit Error Ratio	BER		$<1 \times 10^{-9}$			
TOTAL COMPOSITE POWER	TCP		73.3		dBmV	9 dB tilt, see Figure 9 and Figure 10

ABSOLUTE MAXIMUM RATINGS

Table 3.

Parameter	Rating
V_{CC}	
DC Supply over Voltage (5 Minute)	28 V
RF Input Voltage (RF_{INPUT}), Single Tone	75 dBmV
IADJ Voltage (V_{IADJ})	-1 V to +26 V
Operating Temperature Range	
T_A	-30°C to +85°C
T_{FLANGE}	-30°C to +100°C
Storage Temperature (T_s) Range	-40°C to +100°C

Stresses at or above those listed under Absolute Maximum Ratings may cause permanent damage to the product. This is a stress rating only; functional operation of the product at these or any other conditions above those indicated in the operational section of this specification is not implied. Operation beyond the maximum operating conditions for extended periods may affect product reliability.

ESD CAUTION



ESD (electrostatic discharge) sensitive device. Charged devices and circuit boards can discharge without detection. Although this product features patented or proprietary protection circuitry, damage may occur on devices subjected to high energy ESD. Therefore, proper ESD precautions should be taken to avoid performance degradation or loss of functionality.

PIN CONFIGURATION AND FUNCTION DESCRIPTIONS

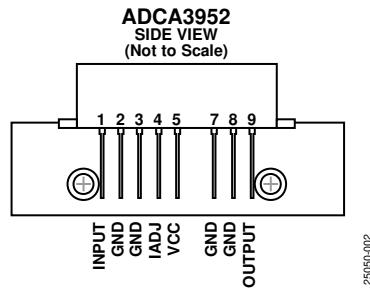

Figure 2. Pin Configuration

Table 4. Pin Function Descriptions

Pin No.	Mnemonic	Description
1	INPUT	RF Input
2, 3	GND	Ground
4	IADJ	Bias Control Pin
5	VCC	Positive Supply Voltage, 24 V Typical
7, 8	GND	Ground
9	OUTPUT	RF Output

TYPICAL PERFORMANCE CHARACTERISTICS

$V_{CC} = 24\text{ V}$, $T_{FLANGE} = 35^\circ\text{C}$, $Z_S = Z_L = 75\ \Omega$, and IADJ (Pin 4) floating, unless otherwise noted.

S-PARAMETERS

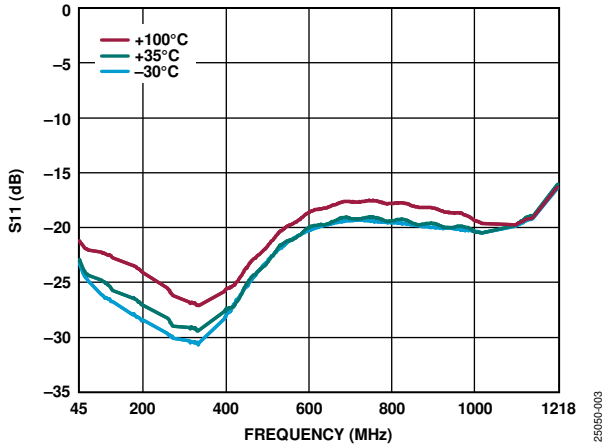

Figure 3. S11 vs. Frequency at Various Temperatures

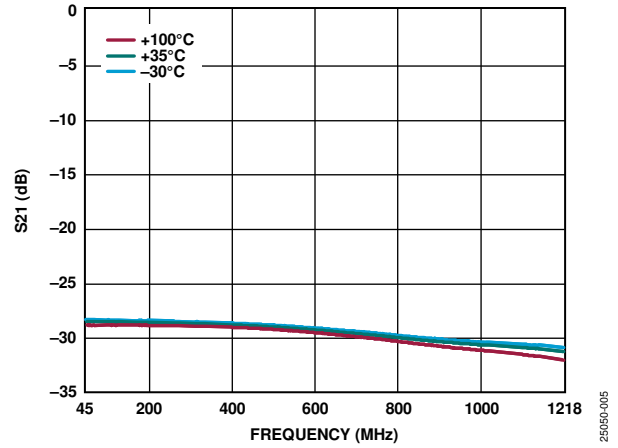

Figure 5. S12 vs. Frequency at Various Temperatures

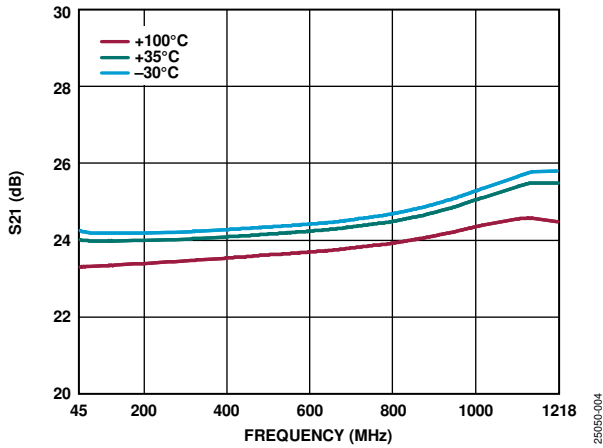

Figure 4. S21 vs. Frequency at Various Temperatures

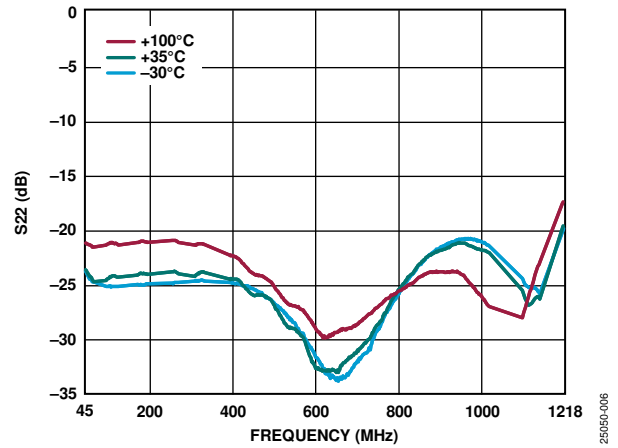

Figure 6. S22 vs. Frequency at Various Temperatures

9 dB TILT PERFORMANCE

9 dB extrapolated tilt, and 190 digital channels (QAM256, ITU-T J.83, Annex B).

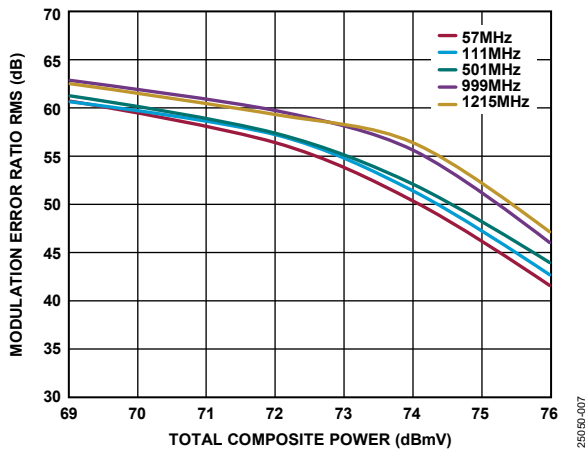

Figure 7. Modulation Error Ratio RMS vs. Total Composite Power at Various Frequencies, 35°C, 9 dB Tilt

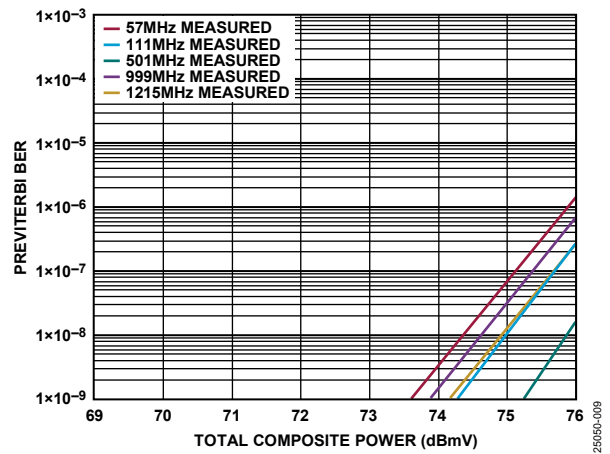

Figure 9. PreViterbi BER vs. Total Composite Power at Various Frequencies, 35°C, 9 dB Tilt

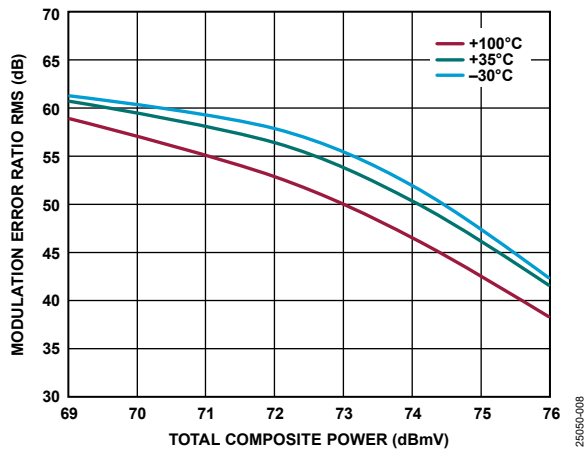

Figure 8. Modulation Error Ratio RMS vs. Total Composite Power at Various Temperatures, 57 MHz, 9 dB Tilt

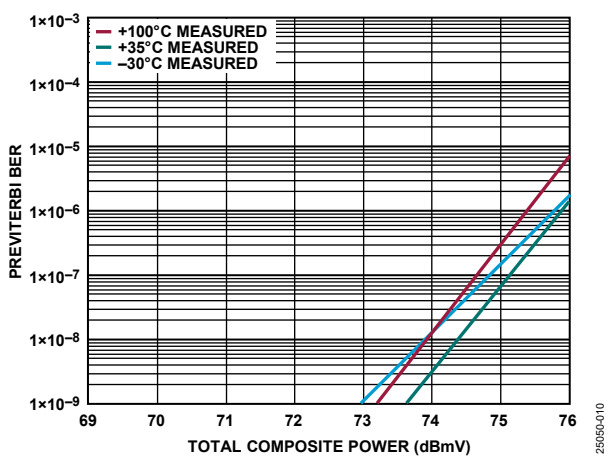

Figure 10. PreViterbi BER vs. Total Composite Power at Various Temperatures, 57 MHz, 9 dB Tilt

THEORY OF OPERATION

The ADCA3952 is a 75 Ω input and output matched module designed for CATV applications. The ADCA3952 uses cascode field effect transistor (FET) feedback amplifiers in a Class A, push pull configuration. The bottom half of the cascode stages are implemented in a single die, linear FET process that minimizes parasitics, thereby enabling higher gain. The top devices in the cascodes are implemented using a linear GaN process able to swing high RF voltages. The frequency of operation is from 45 MHz to 1218 MHz.

Internally, the ADCA3952 module uses a balun to convert the input signal to a balanced signal that feeds the active stages. An output impedance transformer and balun combination converts the balanced GaN signals to an unbalanced 75 Ω output. The output transformer also feeds the dc to the active stages and cancels second-order distortion products coming from the active devices.

The module has a bias control pin (IADJ) that can set the dc current consumption from low bias to the full bias of the device by connecting a resistor from the IADJ pin to ground or by the use of a positive voltage.

The ADCA3952 is unconditionally stable and includes transient and surge protection circuits for robust operation in systems targeting DOCSIS 3.1 and legacy DOCSIS standards.

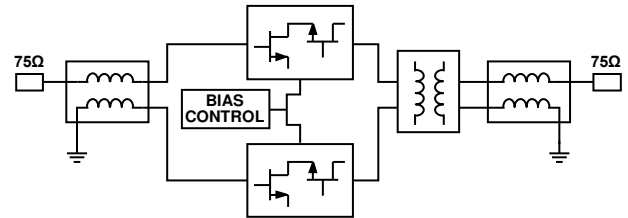

Figure 11. Simplified Schematic

25950-011

APPLICATIONS INFORMATION

Basic connections for operating the ADCA3952 are shown in Figure 14. Both the INPUT pin (Pin 1) and the OUTPUT pin (Pin 9) of the ADCA3952 are matched to 75 Ω. The VCC pin (Pin 5) requires 24 V for typical operation. It is recommended to leave the IADJ pin (Pin 4) open for full bias operation. For bias control on the ADCA3952 supply current, apply an external control voltage between -0.6 V and +1 V at the IADJ pin. Figure 12 illustrates the typical supply current over the control voltages at the IADJ pin of the ADCA3992.

In systems that require the bias current to be lower than the default but it is not critical, a resistor can be placed between the IADJ pin (Pin 4) and ground to set the current (see Figure 15). Figure 13 illustrates the typical supply current of the ADCA3952 in this configuration for a range of resistor values between 100 Ω and 40 kΩ.

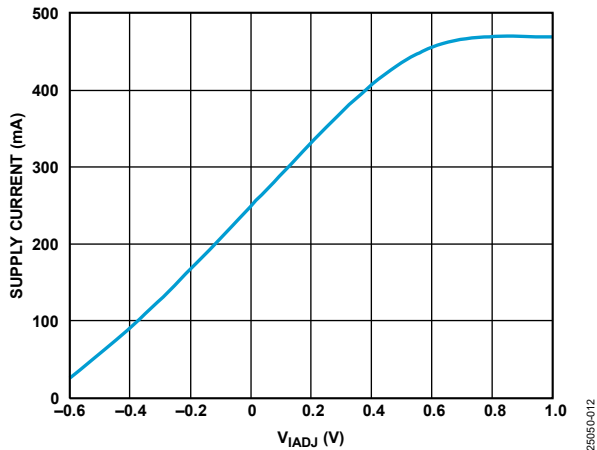

Figure 12. Supply Current vs. V_{IADJ} at the IADJ Pin

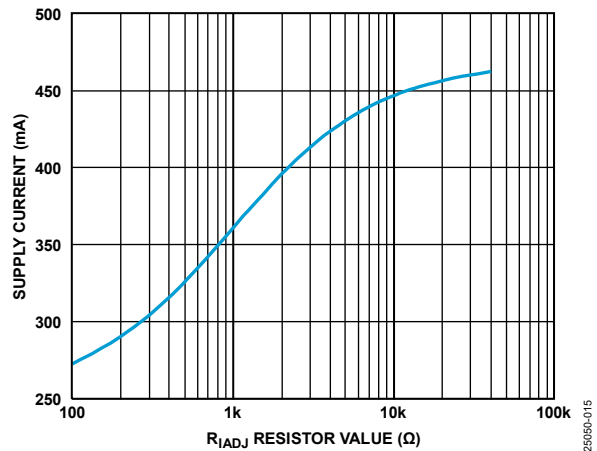

Figure 13. Supply Current vs. R_{IADJ} Resistor Value

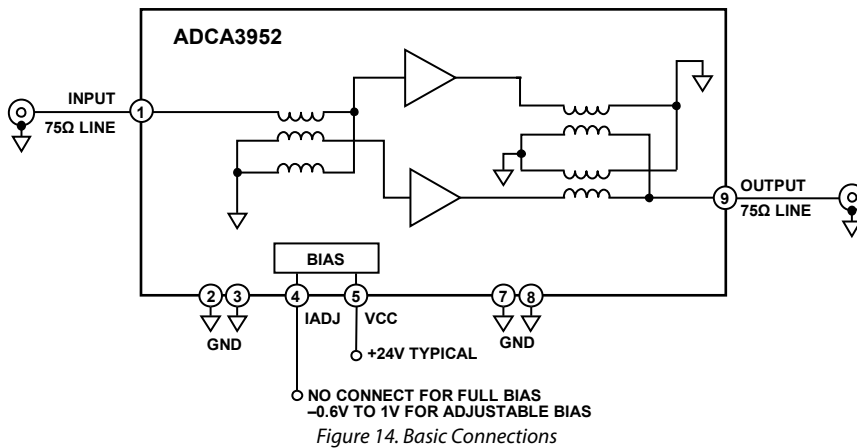

Figure 14. Basic Connections

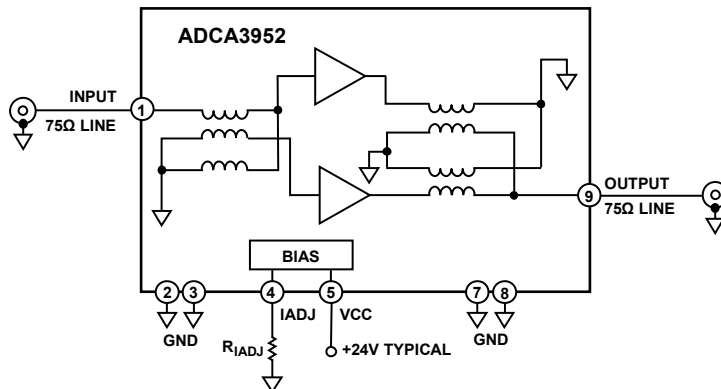

Figure 15. IADJ Bias Control Connections

The ADCA3952 employs a versatile circuit design, allowing system designers to configure the supply voltage at the VCC connection (Pin 5) and the bias control voltage at the IADJ connection (Pin 4) to optimize the power dissipation in any given application. Figure 16 illustrates the modulation error ratio performance trade-off for different bias current configurations.

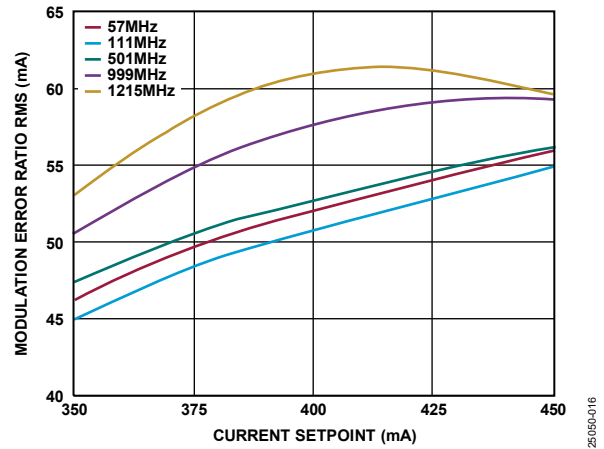

Figure 16. Modulation Error Ratio RMS vs. Current Setpoint for Various Frequencies, Bias = 24 V, 35°C, 9 dB Tilt, Total Composite Power = 72.0 dBmV

OUTLINE DIMENSIONS

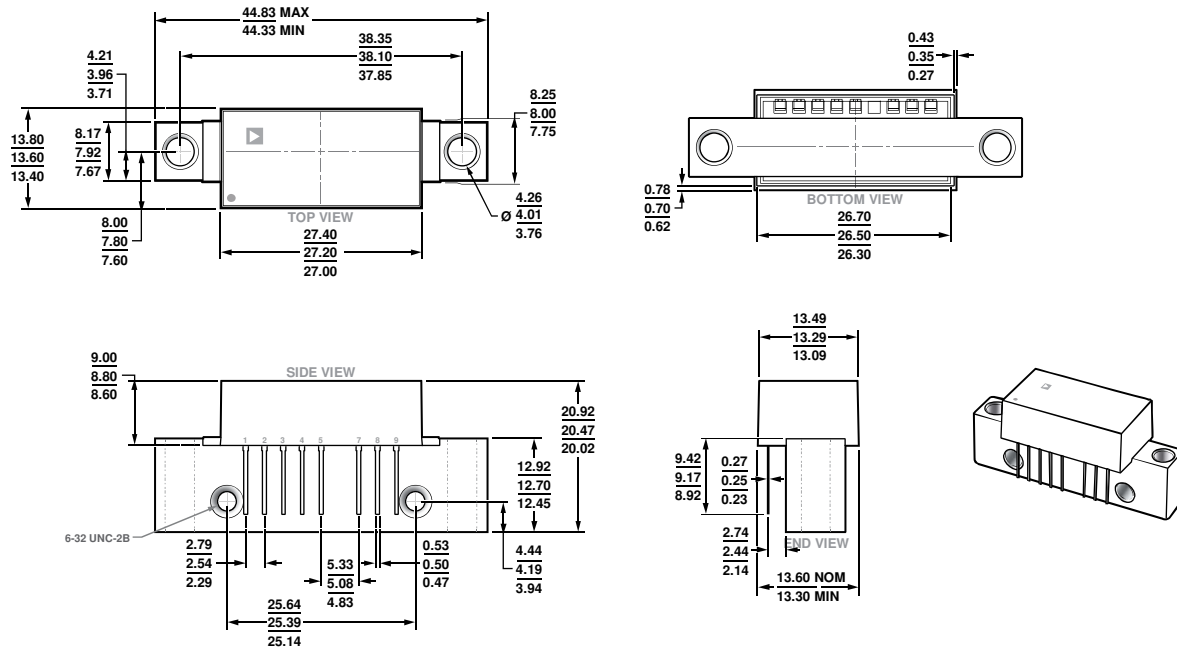

Figure 17. 8-Pin SOT-115J Module Package [MODULE] (ML-8-1)
Dimensions shown in millimeters

ORDERING GUIDE

Model ¹	Temperature Range	Package Description	Package Option
ADCA3952AMLZ	-30°C to +100°C	8-Pin SOT-115J Module Package [MODULE], Box with 25 Pieces	ML-8-1

¹ Z = RoHS Compliant Part.