

Figure 1. The physical photo of TCE28V15AEV1

FEATURES

- Versatile Interface for all necessary measurement nodes
- Easy to use

APPLICATION

Evaluating TEC controller TEC28V15A.

INTRODUCTION

This TEC controller, TEC28V15A, is designed to drive a TEC at high efficiency for regulating the object temperature precisely by controlling the direction and magnitude of the current going through the TEC. It is powered by a DC voltage between 9V to 28V and output current can go up to 15A without using a heat sink.

This evaluation board, TEC28V15AEV1, is designed for evaluating the controller TEC28V15A conveniently. It is recommended to read this application note with the controller datasheet which provides more detail information about the specifications and application guidance for the controller.

The main purpose of using the evaluation board is to let the controller drive a voltage configurable unbreakable dummy laser diode on the board to emulate users' actual expensive laser diode with a programmable current. After making sure the controller works properly and all the features and the set-values meet the requirements of the application, the users can disconnect the dummy laser from the controller by turning a switch and connect a real diode laser onto proper connections of the board. The user will be able to set and monitor the

output current, read the controller's temperature, monitor the working status of the controller, etc.

BOARD DESCRIPTION

The TEC28V15AEV1 Evaluation Board is consisted of a complete application circuit for driving a TEC controller. It can set the output current, the output current limit, has an LED for indicating the working status of the controller, has numerous connection pads and terminal connectors for making connections with external components and instruments. Its physical photo of TEC28V15AEV1 is shown in Figure 1.

The silkscreen layer of the evaluation board is shown in Figure 2 with other top layers, including top silkscreen, top copper, top solder mask, and multilayer (vias). Figure 6 only shows the image of top silkscreen layer. There is no component in the bottom side of the board, so that there is no bottom silkscreen layer image.

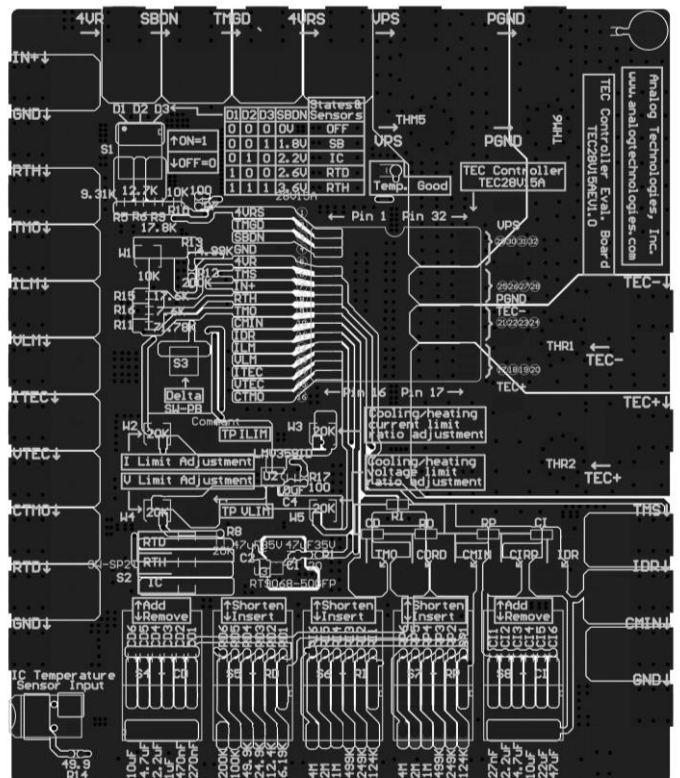

Figure 2. Top Silkscreen Layer with Other Top Layers

There are solder pads on the left, top and the right edges of the board. These pads can be used for connecting the external instruments or components with and the connections can be made by either soldering wires or clipping by alligator clips.

There are 3 terminal blocks also located on the left, top and the right side of the board, their connectors are for the same nodes of the solder pads. See the silkscreen image in Figure 6.

When the thermal control loop of the TEC controller works properly, the LED on the upper location will be lit up.

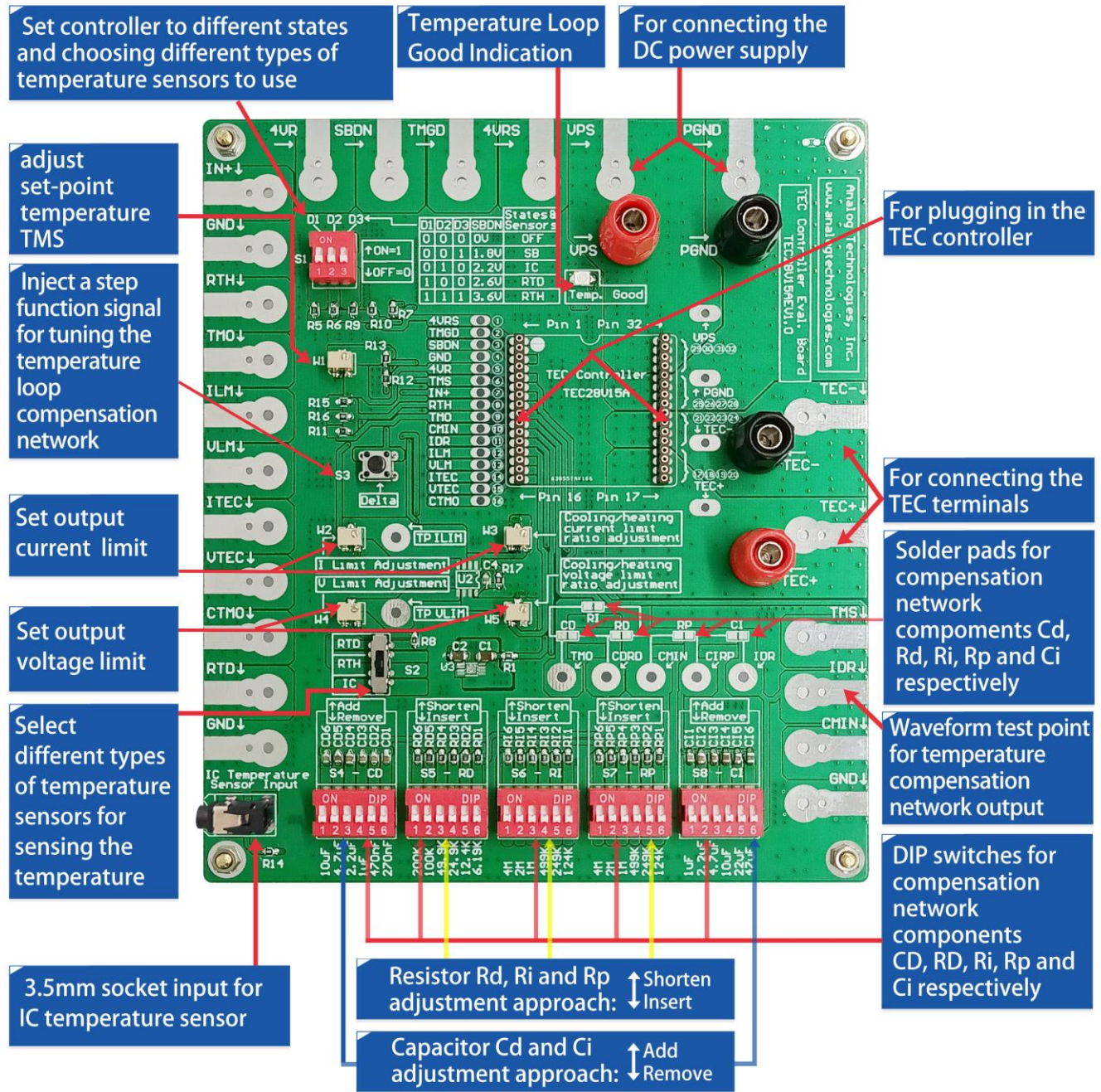

Figure 3. Board Description

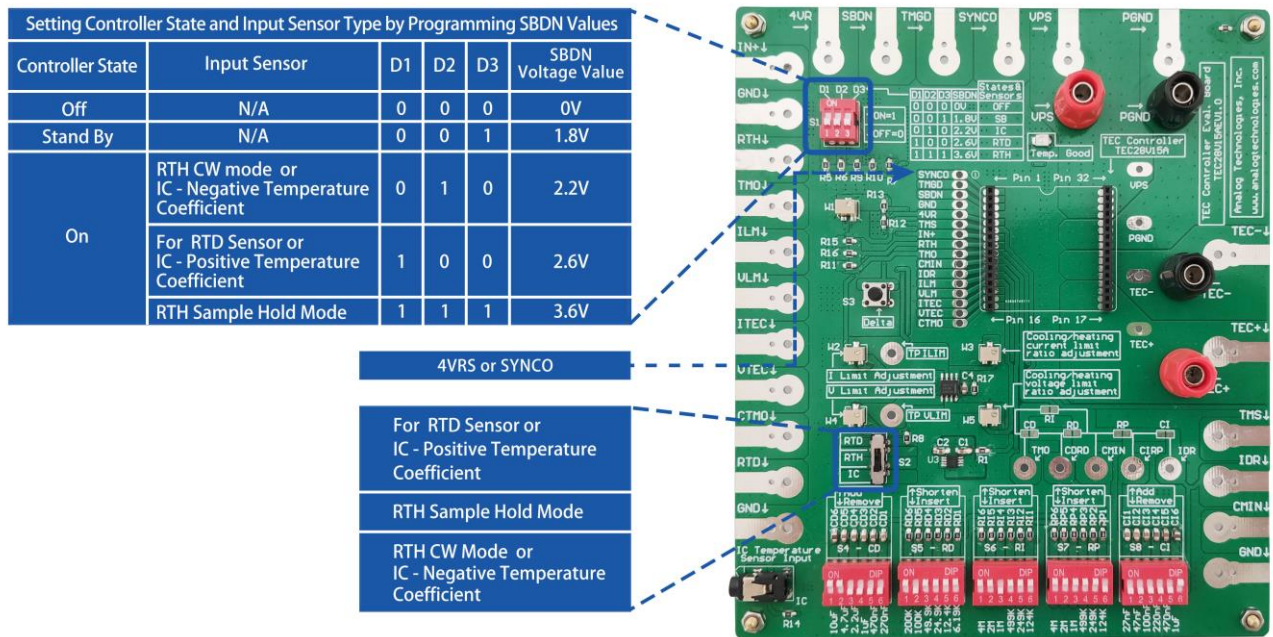

Figure 4. Additional Information for Evaluation Board

Note: RTH sensor has two modes. One is RTH sample hold mode (PWM sample), and the other is CW mode (constant sample).

1. When using CW mode, turn the S2 switch to IC and then turn the S1 to IC. The SBDN voltage is 2.2V. See Figure 5.
2. When using RTH sample hold mode, connect R15 to pin 4VRS. Turn the S2 switch to RTH, and then turn S1 to RTH. The SBDN voltage is 3.6V. See Figure 6.

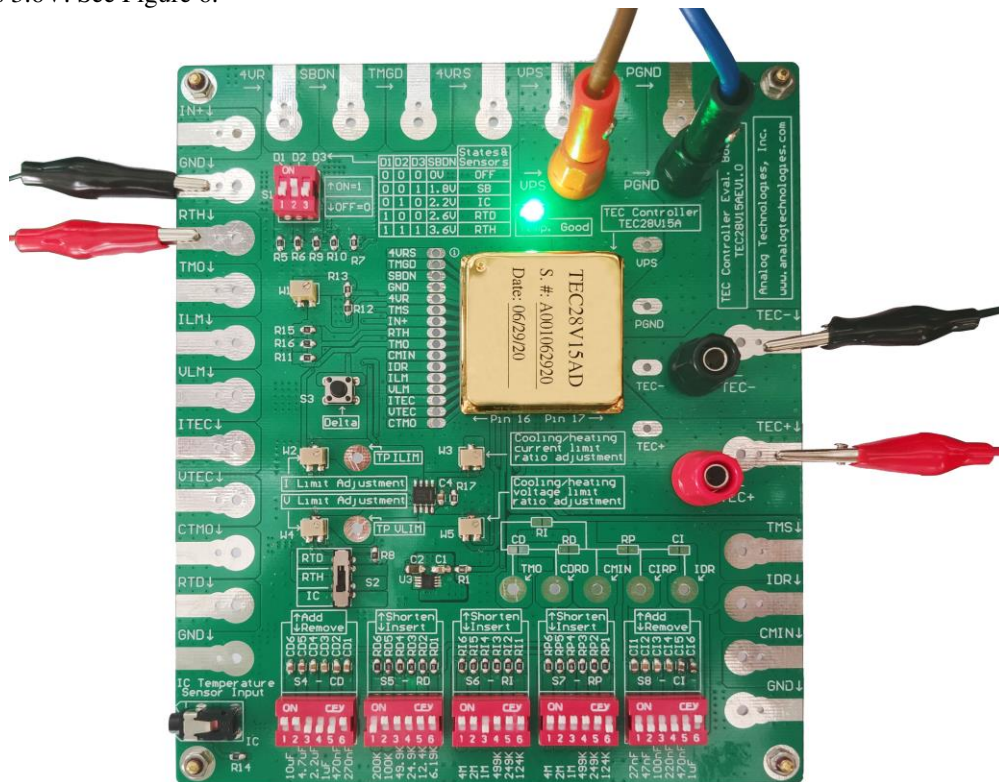

Figure 5. Switch Setting for RTH CW Mode

Table 1. Default Component Values for the Compensation Network

Parameter	Value	Note
R _P	124kΩ	
R _I	1MΩ	
R _D	100kΩ	
C _I	22μF	
C _D	14.7μF	

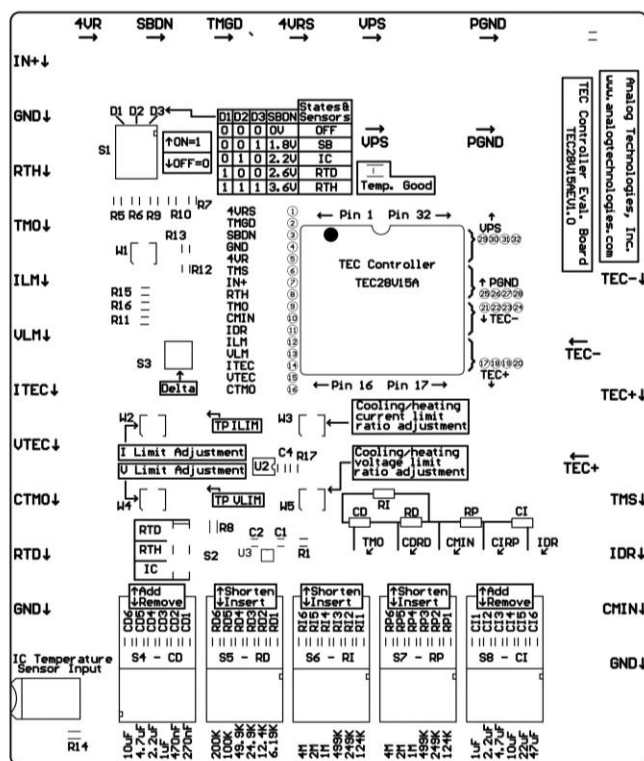

Figure 6. Top Silkscreen

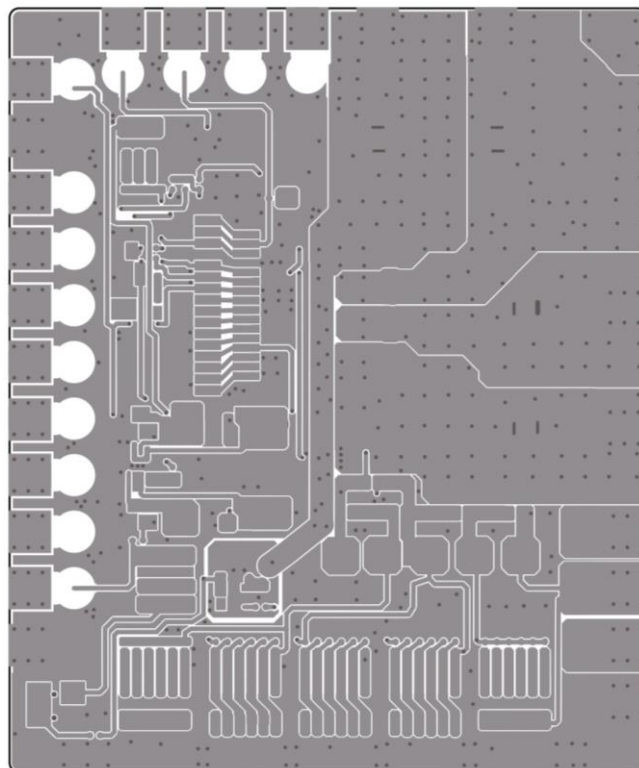

Figure 7. Top Layers without Top Screen Layer

Figure 7 shows the top layers without the silkscreen layer. Figure 8 below shows the bottom layers, including bottom copper, bottom solder mask, and multilayer (vias). Please notice that this is a “see through” image from the top side.

Figures 8 and 9 can be used as a layout reference for designing a system using the TEC28V15A in the system. These are the main points:

1. Connect the power supply return node directly to the PGND pin of the controller before connecting it to any other points. For thermal management purpose, the returned node was not done in this way on the evaluation board.
2. Use as large copper area as possible for the PCB traces of the solder pads of all the pins so that these copper areas become heat-sinks and help dissipating the heat generated by the controller.

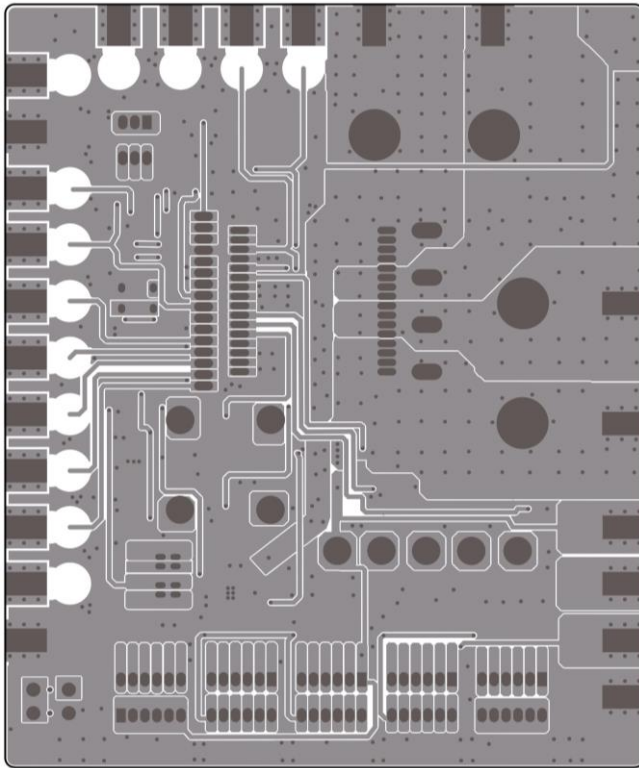

Figure 8. Bottom Layers

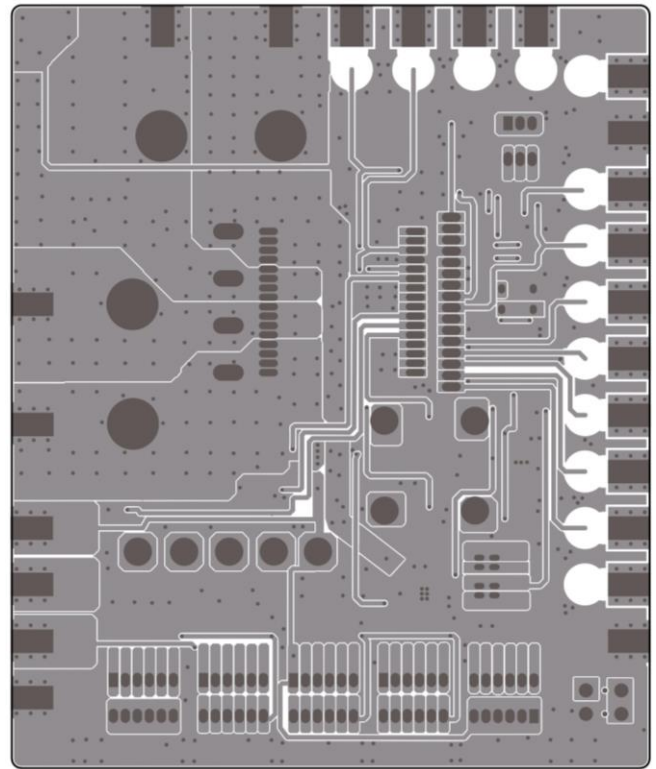

Figure 9. Mirrored Bottom Layers

Figure 9 shows the mirrored bottom layers which is a directly-seen image from the bottom side.

The controller TEC28V15A is located in the center of the TEC28V15AEV1 Evaluation Board. The voltages of all its pins can be measured directly by probing the vias on the left and right side of the module sockets which are connected directly with pins of the electronic module. Some of the pins are also connected to the connectors of the 3 terminal blocks, and/or the soldering pads on the edges of the board. The names of all these nodes are marked on the board.

Please notice that when the board is working, the 5 diodes on the top center may get hot, therefore, avoid touching them with your fingers.

Table 2 is printed on the actual TEC28V15AEV1, which shows the values of V_{SBDN} .

Setting Controller State and Input Sensor Type by Programming SBDN Values						
Controller State	Input Sensor	D1	D2	D3	SBDN Voltage Value	
Off	N/A	0	0	0	0V	
Stand By	N/A	0	0	1	1.8V	
On	RTH CW mode or IC - Negative Temperature Coefficient	0	1	0	2.2V	
	For RTD Sensor or IC - Positive Temperature Coefficient	1	0	0	2.6V	
	RTH Sample Hold Mode	1	1	1	3.6V	

The schematic is shown in Figure 10 below.

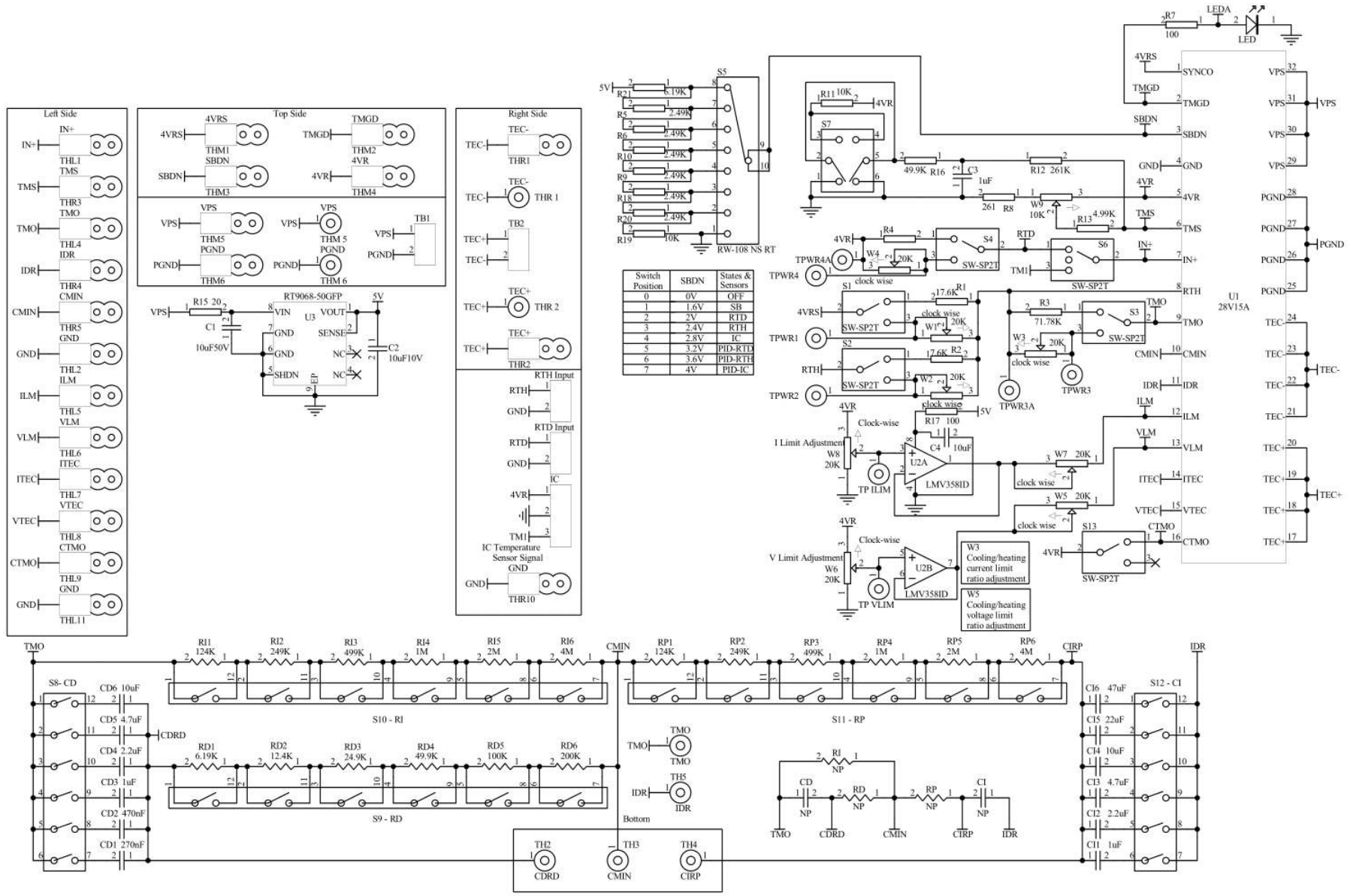

Figure 10. Schematic of TEC28V15AEV1

GETTING STARTED

Hook up the power supply, TEC and thermistor. There are 2 solder pads in the upper right area on the edge for connecting the DC power supply voltages. The connection can be done by clipping or soldering on the pads. Usually the power supply is set from 5V to 28V, a power supply of about having higher voltage than the maximum output voltage. There are also 2 solder pads in the upper right area on the edge for connecting the TEC terminals in the right polarity as indicated onto the board. Connect the thermistor terminals to the board, there is no polarity requirement. On the top of the board, there is the switch bank S1, which is used for adjusting D1, D2 and D3 to achieve different functions, in Table 2. At the same time, adjust the position of S2 with S1. There is an IC port on the bottom left of the edge for IC temperature sensor input. The switch of S3 is used to adjust the compensation network of temperature control loop by inputting a square wave disturbing signal in temperature input point, which enables the system to generate corresponding response waveform. At this time, observe the waveform change by oscilloscope, and adjust and optimize the compensation network of the temperature control loop so as to achieve the best waveform at the same time. Response waveform is achieved by measuring IDR with oscilloscope, as shown in Figure 11 and Figure 12. The compensation network components consist of R_I , R_D , R_P , C_D and C_I , which will be adjusted by S4, S5, S6, S7 and S8. These connections can be done by clipping or soldering on the pads, see Figure 1. Check the evaluation board connections, making sure that they are all correctly connected.

1. Turn on and off the controller. This can be done by either turning off the power supply or turning off the shut-down pin of the controller. To do the latter, turn off the switch D1, D2, D3 in S1 to power off the controller.
2. Check the voltage reference. Use a voltmeter to check the voltage reference pin 4VR having an accurate 4.096V.

Tune the compensation network. The purpose for this step is to match the controller compensation network with the thermal load characteristics thus that the response time and temperature tracking error are minimized. Adjust the potentiometer W1 to change the set-point temperature TMS just a small amount, simulating a step function, or press S3 to simulate a step function. At the same time, connect an oscilloscope at the IDR test pin (on the left side of the evaluation board), set it to a scrolling mode (0.2 Second/Division or slower) and monitor the waveform of IDR as TMS is fed by a step function signal. The circuit in the compensation network is shown in Figure 13 below.

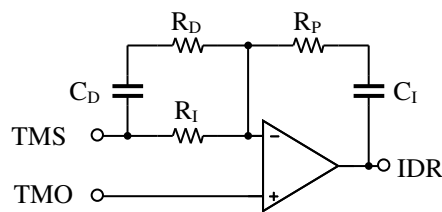

Figure 13. Compensation network

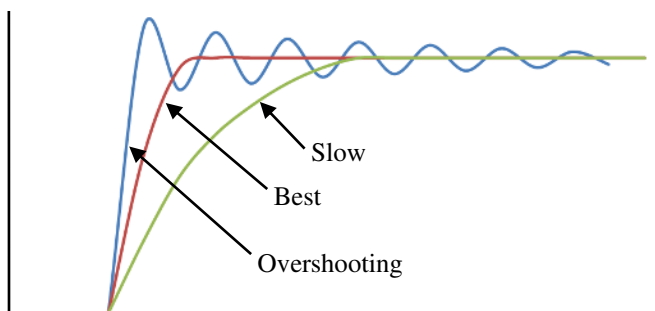

Figure 11. Rise Waveforms of IDR

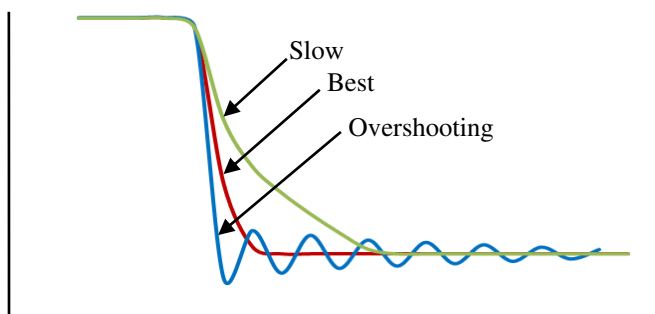

Figure 12. Fall Waveforms of IDR

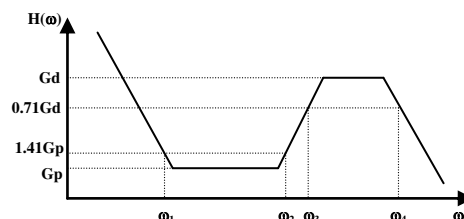

Figure 14. Transfer Function of the Compensation Network

The transfer function of the compensation network, defined as $H(\omega)=IDR(\omega)/TMS(\omega)$, is shown in Figure 14.

In principle, these are the impacts of the components to the tuning results:

- R_P/R_I determines the gain for the proportional component of the feedback signal which is from the thermistor, $G_p = R_P/R_I$, in the control loop, the higher the gain, the smaller the short term error in the target temperature (which is of the cold side of the TEC) compared with the set-point temperature, but the higher the tendency of the loop's instability.
- R_P/R_D determines the gain for the differential component, $G_d = R_P/(R_D/R_I) \approx R_P/R_D$, where symbol “//” stands for two resistors in parallel, since $R_I \gg R_D$, $R_D/R_I \approx R_D$. The higher the gain, the shorter the rise time of the response, the more the overshoot and/or the undershoot will be.

- c. $C_I \times R_P$ determines the corner frequency, $\omega_1 = 1/(C_I \times R_P)$, where the integral component starts picking up, as the frequency goes down. It determines the cut-off frequency below which the TEC controller will start having a large open loop gain. The higher the open loop gain, the smaller the tracking error will be.
- d. $C_D \times R_I$ determines the corner frequency, $\omega_2 = 1/(C_D \times R_I)$, where the differential component starts picking up (see Figure 14), as the frequency goes up.
- e. $C_D \times R_D$ determines the corner frequency, $\omega_3 = 1/(C_D \times R_D)$, where the differential component starts getting flat. It determines the cut-off frequency above which the TEC controller will give extra weight or gain in response.
- f. $1nF \times R_P$ determines the corner frequency, $\omega_4 = 1/(1nF \times R_P)$, where the differential component starts rolling down. Since this frequency is way higher than being needed for controlling the TEC, ω_4 does not need to be tuned. The capacitor is built into the TEC controller module, not the evaluation board.

To start the tuning, turn off the differential circuit by setting C_D Open. Turn W1 quickly by a small angle, back and forth, approximately 5 seconds per change. Set C_I to 1uF, set R_I to 1M, and increase the ratio of R_P/R_I as much as possible, provided the loop is stable, i.e. there are no oscillations seen in IDR. Then, minimize C_I as much as possible, provided the loop is stable. The next step is to minimize R_d and maximize C_D while maintaining about 10% overshoot found in IDR. Optimum result can be obtained after diligent and patient tuning. The tuning is fun and important.

When the TEC controller is used for driving a TEC to stabilize the temperature of a diode laser, there is no need to turn on the laser diode while tuning the TEC controller. To simulate the active thermal load given by the laser diode, setting the set-point temperature lower than the room temperature is enough.

For a typical laser head used in EDFA's or laser transmitters (found in DWDM applications, for instance), $R_I = 1M\Omega$, $R_P = 1M\Omega$, $C_I = 470nF$, $C_D = 2.2\mu F$, and $R_D = 200k\Omega$. These values may vary, depending on the characteristics of a particular thermal load.

To be conservative in stability, use larger C_I and larger R_I ; to have quicker response, use smaller R_d and larger C_D .

The closer to the TEC the thermistor is mounted, the easier to have the loop stabilized, the shorter the rise time and the settling time of the response will be.

- 3. After tuning, the values of the capacitors for C_D and C_I can be read off the capacitor selection switches. The values of the resistors, R_I , R_d and R_P , can be measured by an Ohmmeter by connecting to the resistor pins. As seen in the photo of Figure 6, R_I can be read off between TMS and CMIN test points; R_D can be read off between CMIN and CDRD test points; R_P can be read off between CMIN and

CIRP test points; C_D can be read off between TMS and CDRD test points; C_I can be read off between CIRP and IDR test points.

- 4. After the compensation network is tuned properly, we can now adjust set-point temperature to see if the TEC controller can drive the target temperature to a certain range and with high stability. Turn the temperature set-point TMS potentiometer W1 while monitoring its output voltage at TMS test point (2nd row on left side of the board), watch the LED: when it turns to green, the target temperature is locked to the set-point temperature within 0.1°C or less. The relationship between the set-point voltage vs. the set-point temperature is given in the datasheet. After seeing the LED lock into the set-point temperature, IDR should be a constant voltage as shown in the oscilloscope and the voltage between TMS and TMO should be very small, less than 10mV. When a standard TEC controller is used, the 10mV represent a 0.07° temperature error.
- 5. Set output voltage limit. Adjust the potentiometer W4 to set the voltage limit. TP VLIM is the test point for W4. After the VLM is tuned properly, adjust W5 to achieve different voltage limit for heating and cooling. TP VLIM is the test point for W5. As is shown in Figure 15 and Figure 16.

Set output current limit. Adjust the potentiometer W2 to set the current limit. TP ILIM is the test point for W2. After the current limit is tuned properly, adjust W3 to achieve different ILM for heating and cooling. TP ILIM is the test point for W3. As is shown in Figure 15 and Figure 16.

The schematic is shown in Figure 17 below.

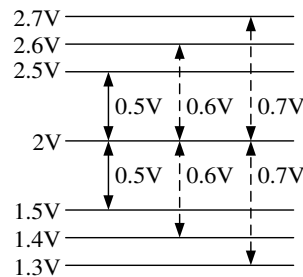

Figure 15. Adjust W2 or W4

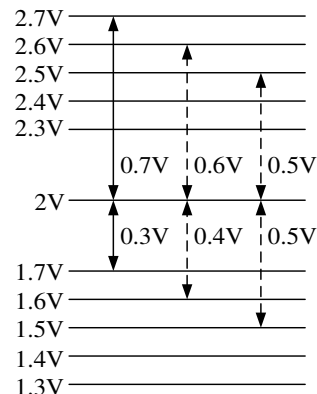

Figure 16. Adjust W3 or W5

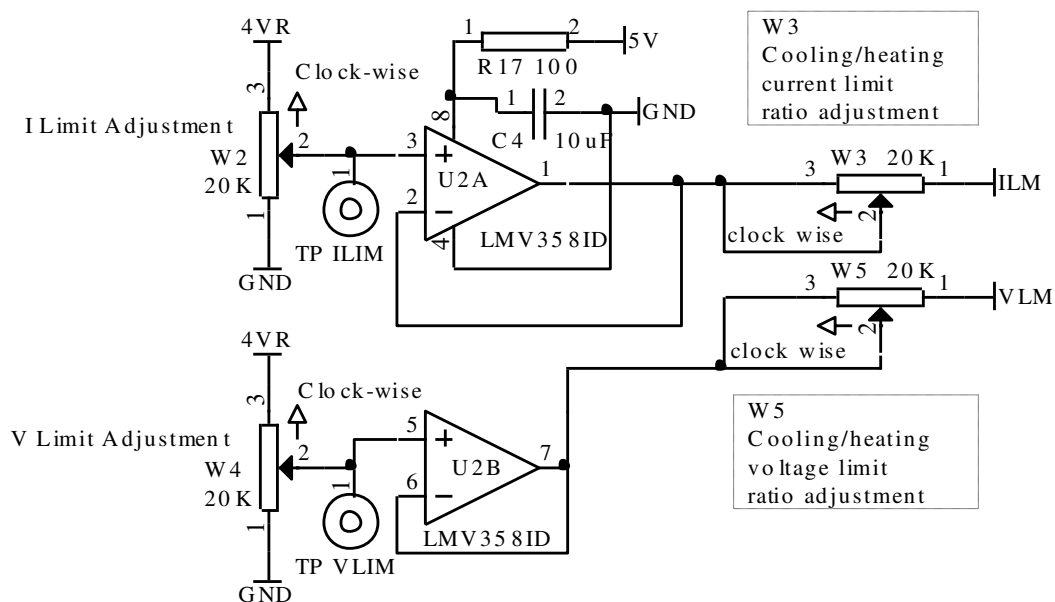

Figure 17. Schematic of Set output voltage or current limit

6. To know more parameters of the TEC controller.

a. To know the actual target temperature, use a voltage meter to measure the voltage between the TMO and the GND pins, the reading result is:

target temperature ($^{\circ}\text{C}$) = $15^{\circ}\text{C} + V_{\text{TMO}} (\text{V}) \times 5^{\circ}\text{C}$ for approximation (see the curve in the TEC controller data sheet).

b. To know how hard the TEC is working, measure the voltage V_{TEC} by a voltage meter or an ADC,
 $V_{\text{TEC}} (\text{V}) = 15 \times V_{\text{VTEC}} (\text{V}) - 30\text{V}$.

When the TEC voltage (from the calculation) is positive, it is in cooling mode; when the TEC voltage is negative, it is in heating mode.

c. To try other values of capacitors not provided by the evaluation board for the capacitors in the compensation network, turn down the capacitor switches, to the “OUT” position, connect the component to the corresponding soldering pads as marked on the evaluation board, see Figure 1.

d. To shut down the TEC controller, turn the Shutdown Control switch D1, D2, D3 in S1 to “Off”, see Figure 1.

e. To control the set-point temperature directly by using a DAC, set the set-point temperature POT W1 to the middle point (25°C), on which the TMS is about 1.5V, the half value of the reference voltage, connect TMS test point to the output of the DAC and use this formula for approximation when the input voltage is between 0.1V and 3.9V:

set-point temperature ($^{\circ}\text{C}$) = $25^{\circ}\text{C} + V_{\text{TMO}} (\text{V}) \times 7.89^{\circ}\text{C}$. The maximum voltage allowed is V_{VPS} (power supply). See the curve in the TEC controller data sheet.

f. To control the TEC voltage directly by using a DAC, connect V_{TEC} to the output of the DAC and use this formula:
 $V_{\text{TEC}} (\text{V}) = 15 \times V_{\text{VTEC}} (\text{V}) - 30\text{V}$.

g. To shut down the TEC controller by using a microprocessor, turn off the Shutdown Control switch, connect SBDN test point (3rd row from the left side, on top side of the board) to one of its digital outputs. When pulling low, the TEC controller is shut off. When pulling high SBDN, the TEC controller is turned on.

h. The evaluation schematic is given in Figure 14.

Using the TEC controller for more applications not described here, and/or having any questions, please feel free to contact us.

NOTICE

1. ATI warrants performance of its products for one year to the specifications applicable at the time of sale, except for those being damaged by excessive abuse. Products found not meeting the specifications within one year from the date of sale can be exchanged free of charge.
2. ATI reserves the right to make changes to its products or to discontinue any product or service without notice, and advise customers to obtain the latest version of relevant information to verify, before placing orders, that information being relied on is current and complete.
3. All products are sold subject to the terms and conditions of sale supplied at the time of order acknowledgment, including those pertaining to warranty, patent infringement, and limitation of liability. Testing and other quality control techniques are utilized to the extent ATI deems necessary to support this warranty. Specific testing of all parameters of each device is not necessarily performed, except those mandated by government requirements.
4. Customers are responsible for their applications using ATI components. In order to minimize risks associated with the customers' applications, adequate design and operating safeguards must be provided by the customers to minimize inherent or procedural hazards. ATI assumes no liability for applications assistance or customer product design.
5. ATI does not warrant or represent that any license, either express or implied, is granted under any patent right, copyright, mask work right, or other intellectual property right of ATI covering or relating to any combination, machine, or process in which such products or services might be or are used. ATI's publication of information regarding any third party's products or services does not constitute ATI's approval, warranty or endorsement thereof.
6. IP (Intellectual Property) Ownership: ATI retains the ownership of full rights for special technologies and/or techniques embedded in its products, the designs for mechanics, optics, plus all modifications, improvements, and inventions made by ATI for its products and/or projects.