

THIS DRAWING IS UNPUBLISHED. RELEASED FOR PUBLICATION ,19 .  
 © COPYRIGHT 19 BY AMP INCORPORATED. ALL RIGHTS RESERVED.

LOC	DIST	REVISIONS			
P	LTR	DESCRIPTION	DATE	DWN	APVD
G	86	F	REV PER 0G3A-0561-01	030CT02	JR MS

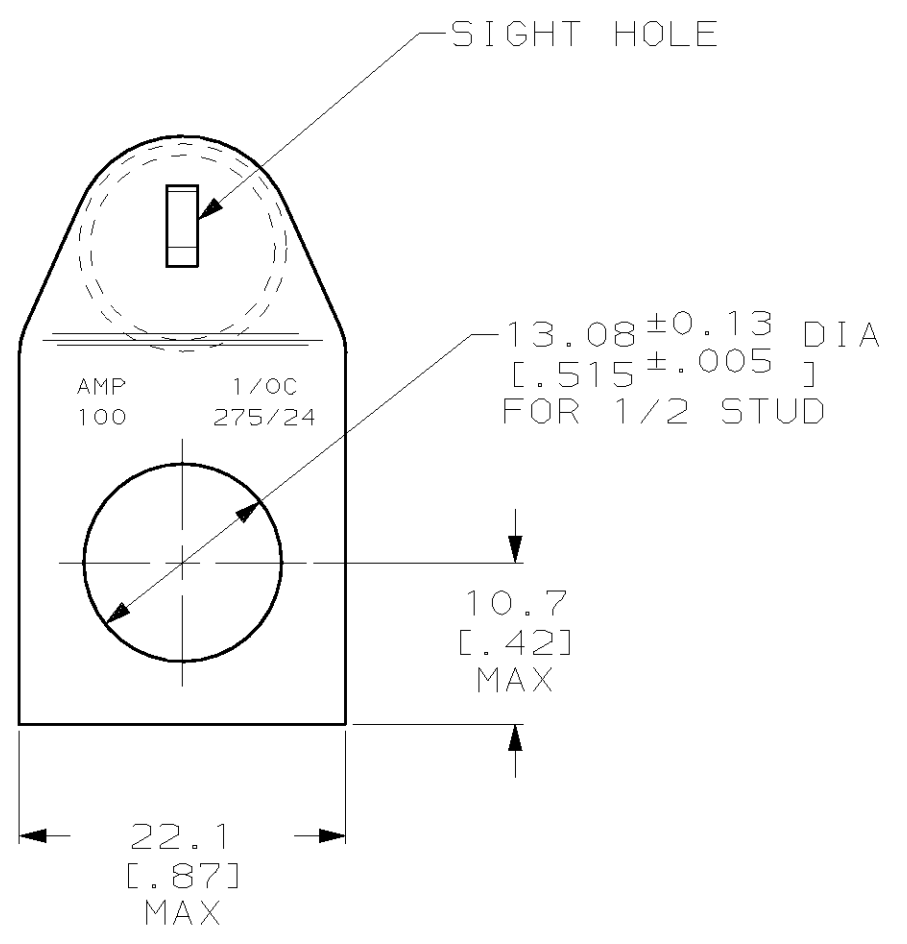
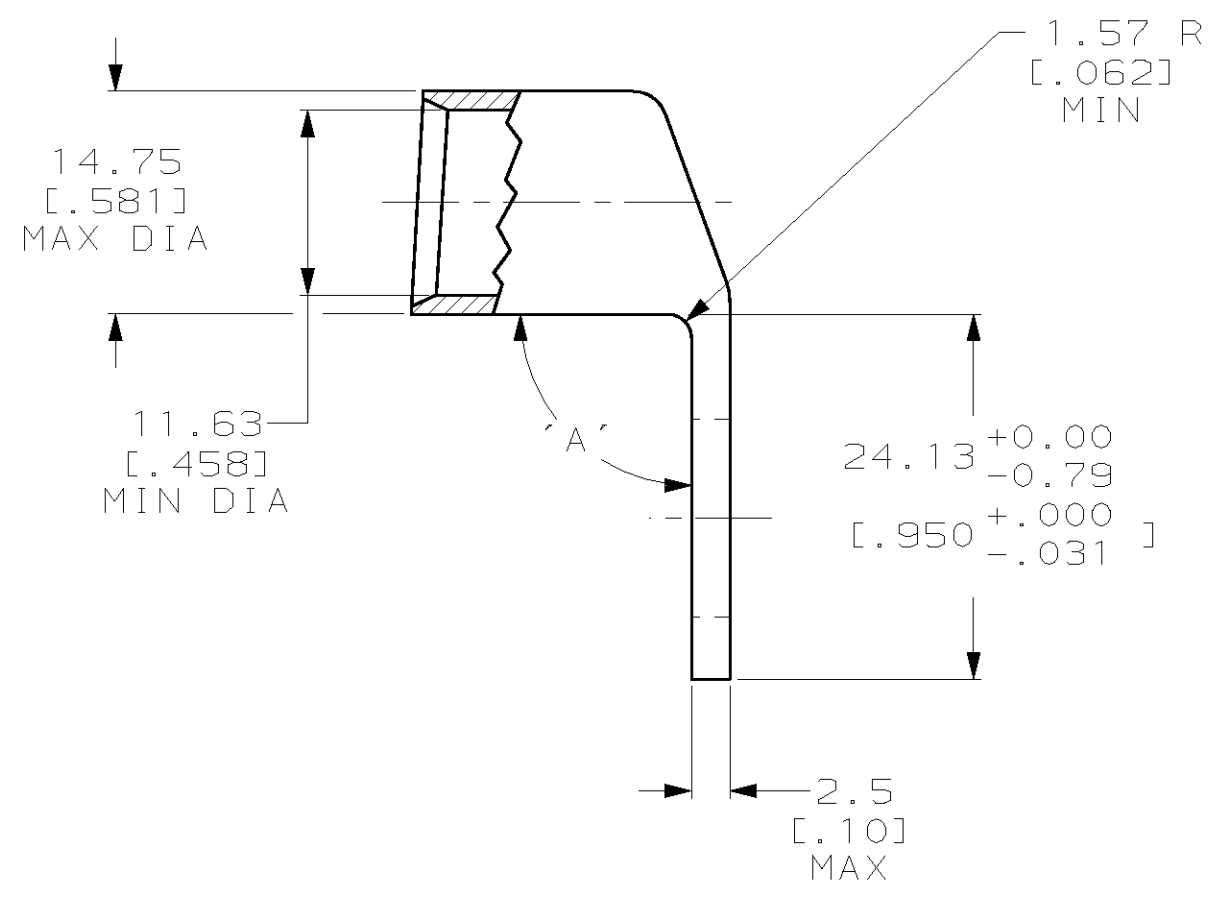

OBSOLETE	120°	54628-3
	90° $\begin{matrix} +10° \\ -0° \end{matrix}$	54628-2
'A'		PART NUMBER

**AMP INCORPORATED**  
**CUSTOMER SERVICE SYSTEMS**

FOR ADDITIONAL PRODUCT INFORMATION OR COPIES OF DRAWINGS AND TECHNICAL DOCUMENTS  
 PRODUCT INFORMATION CENTER  
 1-800-522-6752

FOR APPLICATION TOOLING INFORMATION  
 TOOLING ASSISTANCE CENTER  
 1-800-722-1111

FOR ORDER ENTRY  
 1-800-526-5142

RECOMMENDED OPERATING TEMPERATURE:  
 170° MAX

VOLTAGE RATING:  
 NOT APPLICABLE

WIRE CROSS SECTIONAL AREA RANGE:  
 42.4-60.6mm<sup>2</sup> [83,700-119,500] CIR MILS  
 SOLID OR STRANDED

THIS DRAWING IS A CONTROLLED DOCUMENT FOR AMP INCORPORATED. IT IS SUBJECT TO CHANGE AND THE CONTROLLING ENGINEERING ORGANIZATION SHOULD BE CONTACTED FOR THE LATEST REVISION.

DIMENSIONS:	TOLERANCES UNLESS OTHERWISE SPECIFIED:
mm	
	0 PLC ±-
	1 PLC ±-
	2 PLC ±0.51 [.020]
	3 PLC ±-
	4 PLC ±-
	ANGLES ±-
MATERIAL	FINISH
COPPER PER ASTM B-75 ANNEALED	TIN PLATE 0.00381 [.000150] MIN THK PER MIL-T-10727

DWN	DK SCHRUM	22MAR95	<b>AMP</b> AMP Incorporated Harrisburg, PA 17105-3608
CHK	AJ KAUFMAN	23MAR95	
APVD	JL MECKLEY	23MAR95	
PRODUCT SPEC	NAME		TERMINAL, AMPOWER, WIRE SIZE: 1/0 AWG
APPLICATION SPEC	SIZE	CAGE CODE	DRAWING NO
WEIGHT	A3	00779	C-54628
CUSTOMER DRAWING			SCALE 2:1 SHEET 1 OF 1 REV F